



Standards and Guidelines for Communication Sites

April 2017

68P81089E50-C

Copyrights

The Motorola products described in this document may include copyrighted Motorola Solutions computer programs. Laws in the United States and other countries preserve for Motorola Solutions certain exclusive rights for copyrighted computer programs. Accordingly, any copyrighted Motorola Solutions computer programs contained in the Motorola Solutions products described in this document may not be copied or reproduced in any manner without the express written permission of Motorola Solutions.

© 2017 Motorola Solutions, Inc. All Rights Reserved

No part of this document may be reproduced, transmitted, stored in a retrieval system, or translated into any language or computer language, in any form or by any means, without the prior written permission of Motorola Solutions, Inc.

Furthermore, the purchase of Motorola products shall not be deemed to grant either directly or by implication, estoppel or otherwise, any license under the copyrights, patents or patent applications of Motorola, except for the normal non-exclusive, royalty-free license to use that arises by operation of law in the sale of a product.

Disclaimer

Please note that certain features, facilities, and capabilities described in this document may not be applicable to or licensed for use on a particular system, or may be dependent upon the characteristics of a particular mobile subscriber unit or configuration of certain parameters. Please refer to your Motorola contact for further information.

Trademarks

MOTOROLA, MOTO, MOTOROLA SOLUTIONS, and the Stylized M Logo are trademarks or registered trademarks of Motorola Trademark Holdings, LLC and are used under license. All other trademarks are the property of their respective owners.

European Union (EU) Waste of Electrical and Electronic Equipment (WEEE) directive



■ The European Union's WEEE directive requires that products sold into EU countries must have the crossed out trash bin label on the product (or the package in some cases).

As defined by the WEEE directive, this cross-out trash bin label means that customers and end-users in EU countries should not dispose of electronic and electrical equipment or accessories in household waste.

Customers or end-users in EU countries should contact their local equipment supplier representative or service centre for information about the waste collection system in their country.

Chapter 1. Introduction

1.1 R56 Rewrite Committee Members	1-1
1.2 Organization of This Manual	1-2
1.3 General Statements	1-2
1.4 Safety Information	1-2
1.4.1 Safety Statements Defined	1-2
1.4.2 General Safety Guidelines	1-3
1.5 Standards	1-4
1.5.1 Australia and New Zealand Standards	1-9
1.5.2 Standards Organization Websites	1-12
1.6 Motorola Solutions R56 Support Services	1-13
1.7 Glossary	1-13

Chapter 2. Site Design and Development

2.1 Compliance with RF Energy Exposure Standards	2-1
2.2 The Motorola Solutions Site Design and Integration Team	2-2
2.3 General Outline of Work	2-2
2.4 Planning	2-2
2.4.1 Location of Utility Entrances	2-3
2.4.2 Location of AC Power Neutral-Ground Bond	2-3
2.4.3 Site Development Drawings	2-3
2.4.4 Land Survey and Site Development Staking Considerations	2-4
2.4.5 Temporary Facilities	2-4
2.4.6 Geotechnical Considerations	2-5
2.5 Constructability Review	2-6
2.6 Site Walks	2-6
2.7 Permitting, Zoning, Code and Regulatory Considerations	2-7
2.7.1 Americans With Disabilities Act Considerations	2-7
2.7.2 Federal Clean Water Act Considerations	2-8
2.8 Fire Suppression	2-8
2.9 Electrical Service	2-8
2.10 Foundation Design and Installation	2-9
2.10.1 Foundation and Geotechnical Services	2-9
2.10.2 Concrete Foundation Design and Installation Considerations	2-10
2.10.3 Concrete and Soils Installation Monitoring	2-12
2.11 Site and Facility Acceptance Testing	2-13
2.12 Tower Design and Construction	2-14
2.12.1 Tower Design Drawings	2-15
2.12.2 Design Considerations to Help Reduce Effects of Lightning	2-16
2.12.3 Tower Safety	2-18
2.12.4 Regulations Affecting Towers	2-18
2.12.5 Securing the Tower	2-19
2.12.6 Antenna and Dish Antenna Loading	2-19
2.12.7 Tower Construction	2-20
2.12.8 Tower Transmission Cables	2-21
2.13 Site Drawings of Record	2-22

Chapter 3. Communication Site Building Design and Installation

3.1 Site Categories	3-1
3.2 Definitions of Communications Equipment Sites	3-2
3.3 Building/Shelter Design and Location Considerations	3-3
3.3.1 Location Considerations	3-5
3.3.2 Equipment Shelter Off-Loading	3-5
3.3.3 Seismic Considerations	3-5
3.4 Foundation Considerations	3-6
3.5 Floor Loading	3-7
3.6 Ceilings and Floors	3-7
3.6.1 Ceilings	3-7
3.6.2 Floors	3-8
3.7 Weatherproofing/Sealing	3-8
3.7.1 Transmission Line Entry Ports	3-8
3.7.2 Sealing of Buildings and Shelters	3-9
3.8 Heating, Ventilation, and Air Conditioning	3-10
3.8.1 HVAC Design Considerations	3-11
3.9 Special Considerations for Telephone Central Offices and Switch Rooms	3-13
3.9.1 Lightning Damage Prevention	3-13
3.9.2 Power Source Protection	3-13
3.9.3 Central Office Layout	3-13
3.10 Cable Trays	3-13
3.10.1 Cable Tray Selection	3-14
3.10.2 Cable Management Under Raised Floors	3-16
3.10.3 Wire-Mesh Cable Trays	3-16
3.10.4 Cable Tray Layout and Design	3-17
3.10.5 Cable Tray Installation	3-17
3.10.6 Cable Tray Safety Considerations	3-18
3.11 Lighting	3-19
3.11.1 General Interior Lighting Specifications	3-19
3.11.2 Interior Lighting Quality	3-19
3.11.3 Emergency Interior Lighting	3-19
3.11.4 Exterior Lighting	3-20
3.12 Fire Protection and Safety	3-20
3.12.1 Reference Publications	3-20
3.12.2 Training and Proper Usage	3-21
3.12.3 Fire Classifications	3-21
3.12.4 Portable Extinguishers	3-22
3.12.5 Fixed Fire Detection, Alarm and Suppression Systems	3-25
3.12.6 Warning Signs	3-27
3.12.7 Power Sources	3-28
3.12.8 Fixed Systems Comparison	3-28
3.13 Safety Equipment	3-29
3.13.1 First Aid Kit	3-29
3.13.2 Typical Battery Safety Kit	3-29
3.14 On Site Communications	3-30
3.15 Signage	3-31
3.15.1 Minimum Required Signage	3-31
3.15.2 Additional Signage	3-33

Chapter 4. External Grounding (Earthing) and Bonding

4.1	Introduction to External Grounding (Earthing) and Bonding	4-1
4.2	Lightning Activity and Exposure	4-3
4.3	Site Type Classification: Definitions	4-5
4.3.1	Light Duty (Type A)	4-5
4.3.2	Standard Duty (Type B)	4-6
4.3.3	Extra Duty (Type B2)	4-6
4.4	Common Grounding	4-6
4.5	Grounding System Component and Installation Requirements	4-7
4.5.1	Grounding (Earthing) Electrodes	4-8
4.6	Grounding (Earthing), Bonding and Down-Conductors	4-37
4.6.1	General Specifications	4-37
4.6.2	Bending and Routing Grounding (Earthing), Bonding and Down-Conductors	4-38
4.6.3	Protecting and Securing Grounding, Bonding and Down-Conductors	4-39
4.6.4	External Ground Bus Bar	4-43
4.6.5	Tower Ground Bus Bar	4-46
4.7	Dissimilar Metals and Corrosion Control	4-52
4.7.1	Corrosion Related to Soil Type	4-52
4.7.2	Galvanic Corrosion	4-54
4.7.3	Miscellaneous General Information	4-55
4.7.4	Methods to Help Reduce Corrosion	4-55
4.8	Bonding to the External Grounding and Bonding System	4-57
4.8.1	General Requirements for Bonding to External Grounding	4-57
4.8.2	Above-Grade Mechanical Lugs and Connection Devices	4-58
4.8.3	Securing Hardware	4-61
4.8.4	Above-Grade Mechanical Bonding Requirements	4-62
4.8.5	Bonding Objects in Blind Locations	4-63
4.8.6	Anti-Oxidant Compound	4-63
4.8.7	Below-Grade Connections	4-64
4.8.8	Bonding Summary	4-72
4.9	Minimum Site Grounding (Earthing) Requirements	4-74
4.9.1	Type "A" Site: Light Duty	4-75
4.9.2	Type "B" and "B2" Sites: Standard and Extra Duty	4-75
4.9.3	Grounding (Earthing) Electrode System Resistance Requirements	4-76
4.9.4	Supplemental Grounding (Earthing)	4-78
4.9.5	Type "A" Site Grounding (Earthing)	4-78
4.9.6	Tower Grounding (Earthing)	4-79
4.9.7	Dedicated Communications Building Grounding (Earthing)	4-92
4.9.8	Generators External to the Building	4-93
4.9.9	Outdoor Cabinet Grounding (Earthing) and Bonding	4-94
4.10	Bonding of RF Preamplifiers and Other Active Devices on Tower	4-95
4.10.1	Grounding and Bonding of RF Transmission Lines and Other Communications Cables	4-97
4.10.2	Metallic Objects Requiring Bonding	4-101
4.10.3	Fuel Tank Bonding	4-112
4.10.4	Solar Photovoltaic Systems	4-113
4.11	Grounding Roof-Mounted Antenna Masts and Metal Support Structures	4-114
4.11.1	Side Mounted Antenna Grounding	4-117
4.12	Grounding (Earthing) Rooftop Mounted Tower Structures	4-119
4.12.1	Lightning Protection System	4-119
4.12.2	Rooftop Tower Bonding to the Lightning Protection System	4-120

4.13	Special Grounding (Earthing) and Bonding Applications	4-122
4.13.1	Dispatch Centers Co-Located With Communications Towers	4-122
4.13.2	Two or More Separate, Electrically Interconnected Buildings in the Same Area	4-124
4.13.3	Grounding and Bonding for Access Points, Wireless Routers, Point-to-Point and Similar Devices	4-126
4.13.4	Metal Shipping Containers used as Communications Buildings	4-131
4.13.5	Grounding (Earthing) Electrode Systems Covered by Concrete or Asphalt	4-132
4.13.6	Water Tank and Water Tower Installations	4-132
4.14	Special Situations	4-134
4.14.1	Rooftop Communications Sites	4-134
4.14.2	Sites With Limited Space for the Grounding Electrode System	4-136
4.14.3	Towers with Limited Space for a Ground Ring	4-137
4.14.4	Stone Mountaintops	4-138
4.14.5	Shallow Topsoil Environments	4-141
4.14.6	Sand, Coral or Limestone Environments	4-143
4.14.7	Arctic Environments	4-144

Chapter 5. Internal Bonding and Grounding (Earthing)

5.1	Introduction to Internal Bonding and Grounding (Earthing)	5-1
5.2	General Application	5-3
5.3	Common Grounding (Earthing)	5-6
5.4	Single-Point Grounding (Earthing) and the Single-Point Entry Window	5-7
5.5	Electrical Service Grounding and Entrance Point	5-8
5.6	Internal Bonding System Components and Installation Requirements	5-9
5.6.1	Master Ground (Earth) Bus Bar or Primary Bonding Bar	5-10
5.6.2	Integrated Panels and Cable Entry Ports	5-15
5.6.3	Sub System Ground Bus Bar or Secondary Bonding Bar	5-17
5.6.4	Rack Ground Bus Bar or Rack Bonding Bar	5-27
5.6.5	Network-Equipment Bonding Bar	5-32
5.6.6	Bonding and Grounding (Earthing) Conductors	5-39
5.7	Bonding and Grounding Infrastructure Subsystems	5-49
5.7.1	Equipment Bonding Bus Conductor	5-49
5.7.2	Bonding Backbone and Bonding Backbone Conductor	5-53
5.7.3	Backbone Bonding Conductor	5-55
5.7.4	Internal Perimeter Bonding Bus Conductor	5-56
5.7.5	Halo	5-59
5.7.6	Supplementary Bonding Network or Bonding Grid	5-59
5.8	Connection Methods for Internal Bonding and Grounding (Earthing) System	5-64
5.8.1	General Bonding Requirements	5-65
5.8.2	Lugs and Connection Devices	5-68
5.8.3	Securing Hardware	5-71
5.8.4	Mechanical Bonding Requirements	5-71
5.8.5	Bonding Objects in Blind Locations	5-72
5.8.6	Anti-Oxidant Compound	5-72
5.8.7	Exothermic Welding	5-73
5.8.8	Bonding to Equipment and Ancillary Support Apparatus	5-73
5.8.9	Bonding to the Primary Bonding Bar, Secondary Bonding Bar and Rack Bonding Bar ...	5-74
5.8.10	Bonding to Bonding Bus Conductors	5-77
5.8.11	Bonding to Bonding Backbone Conductors and Backbone Bonding Conductors	5-79
5.9	Bonding Equipment to Internal Bonding and Grounding (Earthing) System	5-79
5.9.1	Equipment and Ancillary Support Apparatus Bonding	5-84

5.10 Bonding and Grounding (Earthing) for Specific Site Types	5-124
5.10.1 Bonding and Grounding Requirements for Stand-Alone Shelters	5-124
5.10.2 Bonding and Grounding (Earthing) for Small Commercial Building Installations	5-127
5.10.3 Bonding and Grounding (Earthing) for Large and Multi-Story Commercial Building Installations	5-128
5.10.4 Bonding and Grounding (Earthing) for Integrated and Rooftop Communication Sites ..	5-130
5.10.5 Bonding and Grounding (Earthing) for Dispatch Centers and Network Operator Positions	5-133
5.11 Testing the Internal Bonding and Grounding (Earthing) System	5-140
5.11.1 Bonding Continuity	5-140
5.11.2 Current Testing	5-140

Chapter 6. Power Sources

6.1 Safety for Power Sources	6-1
6.1.1 Lockout/Tagout	6-1
6.2 AC Power	6-2
6.2.1 Critical Operations Power Systems (COPS)	6-3
6.2.2 Electrical Service	6-4
6.2.3 Location of Neutral-Ground Bond	6-5
6.2.4 Separately Derived Systems Using Transformers	6-7
6.2.5 Interior Electric	6-8
6.2.6 Power Panels	6-9
6.2.7 Circuit Protection	6-10
6.2.8 Conductors	6-10
6.2.9 Conduit	6-11
6.2.10 Hardwiring of Equipment and Dedicated Receptacles	6-11
6.2.11 Power Distribution Units (PDU)	6-12
6.2.12 Receptacles	6-13
6.2.13 Receptacle Strips	6-17
6.3 Power Quality	6-18
6.3.1 Fundamentals of Power Quality	6-18
6.3.2 Common Causes of Power Quality Problems	6-18
6.3.3 Common Effects of Power Quality Problems	6-21
6.3.4 Common Power Quality Problem Remedies	6-21
6.3.5 Power Quality Testing Thresholds	6-22
6.3.6 Steps to Developing a Power Quality Plan	6-23
6.3.7 General Recommendations to Help Promote Good Power Quality	6-23
6.3.8 Power Quality Testing Locations	6-23
6.3.9 Power Quality Testing Duration	6-24
6.4 Rectifier/DC Power Systems	6-25
6.4.1 Rectifier System Requirements	6-25
6.4.2 DC Distribution	6-26
6.4.3 Low Voltage Disconnect	6-26
6.4.4 Overcurrent Protection	6-26
6.4.5 Power Cabling Capacity	6-26
6.4.6 Floor and Ceiling Runs, Plenum Grade and Risers Cabling	6-27
6.4.7 DC Power Budget	6-28
6.5 Uninterruptible Power Supplies	6-28
6.5.1 Determining UPS Output Requirements	6-29
6.6 Alternate Power Sources	6-29
6.6.1 System Planning for Alternate Power Sources	6-30

6.6.2	Requirements for Alternate Power Sources	6-30
6.6.3	Installation of Alternate Power Sources	6-31
6.6.4	Maintenance of Alternate Power Sources	6-31
6.7	Battery Systems	6-31
6.7.1	Battery Safety	6-31
6.7.2	Battery Containment Area	6-33
6.7.3	Battery Backup Duration	6-34
6.7.4	Battery Sizing	6-35
6.7.5	Battery Rating	6-35
6.7.6	Multiple Battery Strings	6-35
6.7.7	Battery Charging	6-36
6.7.8	Battery Temperature Requirements	6-36
6.7.9	Battery Installation	6-36
6.7.10	Battery Maintenance Disconnect	6-38
6.8	Standby Generator Systems	6-38
6.9	Generator Output and Derating Considerations	6-38
6.9.1	Generator Placement	6-39
6.9.2	Fuel Supply for Generators	6-40
6.9.3	Transfer Switch	6-41
6.9.4	Electrical Wiring Considerations	6-41
6.9.5	Installation Plan	6-42
6.9.6	Alarms, Meters and Gauges	6-42
6.9.7	Generator Installation Grounding	6-43
6.9.8	Generator Installation	6-43
6.9.9	Generator Startup	6-44
6.9.10	Generator Safety	6-44

Chapter 7. Surge Protective Devices

7.1	Introduction to Surge Protection	7-1
7.2	Definitions for Surge Protection	7-5
7.3	Conformance with UL 1449 4th Edition	7-8
7.4	Technologies Available	7-9
7.5	AC Power Surge Protective Devices (SPD) Requirements	7-9
7.5.1	AC SPD Requirements Based on Facility Description	7-9
7.5.2	Motorola Solutions Definition of SPD Types	7-12
7.5.3	SPD Specifications for Safety and Performance	7-18
7.6	AC Power SPD Requirements	7-20
7.6.1	Location	7-20
7.6.2	Interconnecting Raceway or Conduit	7-20
7.6.3	Circuit Breaker or Disconnecting Means	7-20
7.6.4	Conductor Size, Length and Routing	7-21
7.6.5	AC Power Performance Evaluation	7-21
7.7	Telephony, Data, Signaling, Alarm and Network Circuit Protection	7-21
7.7.1	Cable Separation	7-23
7.7.2	Bonding and Grounding (Earthing) of Telephone, Data, Signaling, Alarm and Network Circuit Surge Protective Devices	7-23
7.7.3	Links Provided by the Telephone (Wireline) Service Provider	7-23
7.7.4	Microwave Links	7-27
7.7.5	Inter-building Cabling Links	7-28
7.7.6	Telephone Exchange Protection	7-29
7.7.7	Computer Network Protection (Ethernet)	7-29

7.7.8 Alarm Circuits	7-31
7.7.9 SPD Summary and Performance Evaluation for Telephone, Data, Signaling and Network Circuit Protection	7-32
7.8 Closed Circuit Television and Security	7-34
7.9 Broadband Point-to-Point and Multi-point Wireless Links	7-35
7.10 Satellite and Television Broadband Services	7-38
7.11 RF Surge Protection	7-38
7.11.1 RF Surge Protection Design	7-43
7.11.2 RF Surge Protection Technology Overview	7-43
7.11.3 RF SPD Qualifications	7-46
7.11.4 Tower Electronics	7-48
7.11.5 GPS Receiver Protection	7-48
7.11.6 Tower Lighting	7-49
7.11.7 Surge Protection Considerations for Dispatch Centers and Operator Positions	7-50
7.12 Direct Current Systems Surge Protection	7-52
7.12.1 DC Powered Outdoor Equipment	7-53
7.12.2 Localized DC Distribution	7-53
7.12.3 Recommended DC SPD Technology and Location	7-54
7.13 AC Power Line SPD Test Certification Requirements	7-56
7.13.1 Test Methods	7-57
7.13.2 Component Level Surge Test	7-57
7.13.3 Impulse Surge Durability Test Requirements	7-57
7.13.4 Maximum Discharge Current Test	7-58
7.13.5 SPD Qualifications Summary	7-60
7.14 Electromagnetic Pulse (EMP)	7-63
7.14.1 Referencing MIL-STD 188-125 for Commercial Applications	7-63
7.14.2 MIL-STD 188-125 – Purpose	7-63
7.14.3 MIL-STD 188-125 – Application to Non-US Military Situations	7-63
7.14.4 Conclusion	7-64

Chapter 8. Minimizing Site Interference

8.1 Interference Protection Recommendations	8-1
8.1.1 Minimum Transmitter Protection Requirements	8-1
8.1.2 Minimum Receiver Protection Requirement	8-3
8.2 General Site Environmental Requirements	8-3
8.3 Other Band Architecture—Overview	8-3
8.3.1 Spectrum Usage History	8-4
8.3.2 Forms of Interference	8-4
8.3.3 OBA Interference Mitigation	8-4
8.3.4 Antenna Network Components	8-6
8.3.5 Optimization and Testing	8-6
8.3.6 Maintenance	8-7
8.4 Mitigating External Intermodulation and TN/RD Interference	8-7
8.4.1 Intermodulation	8-7
8.4.2 Transmitter Noise/Receiver Desense (TN/RD)	8-7
8.4.3 Simplex Multi-Frequency Stations	8-8

Chapter 9. Equipment Installation

9.1 Introduction to Equipment Installation	9-1
9.1.1 Safety for Equipment Installation	9-2
9.1.2 Installation Practices	9-3

9.2	General Installation Considerations	9-4
9.3	Facility Readiness	9-4
9.3.1	Installations at Existing Sites	9-4
9.4	General Considerations for Layout, Work Areas and Spacing	9-5
9.4.1	Spacing Requirements	9-5
9.5	Seismic Considerations	9-9
9.5.1	Seismic Requirements and Recommendations	9-10
9.5.2	Seismic Zone 0	9-15
9.5.3	Seismic Zones 1 and 2	9-15
9.5.4	Seismic Zone 3	9-15
9.5.5	Seismic Zone 4	9-16
9.6	Level, Plumb and Squareness	9-16
9.7	Equipment Anchoring	9-17
9.7.1	Mounting on Concrete Floors	9-17
9.7.2	Mounting on Wood or Similar Surfaces	9-20
9.7.3	Anchoring Equipment to Raised Floors	9-21
9.7.4	Anchoring Overhead and Wall-Mounted Equipment	9-22
9.7.5	Equipment on Wheels	9-22
9.8	Equipment Installation Within Racks or Cabinets	9-22
9.9	Ancillary Equipment Mounting	9-23
9.10	Equipment Cabling	9-23
9.10.1	Cable Installation Requirements	9-23
9.10.2	Communications Cabling Requirements for Plenums and Other Spaces Used for Environmental Air	9-26
9.10.3	Communications Cabling Requirements for Risers	9-29
9.10.4	Fire Stopping Requirements	9-29
9.10.5	Cabling Requirements For Cable Trays or Ladders	9-30
9.10.6	Cabling Requirements for Equipment in Racks and Cabinets	9-33
9.10.7	AC Power Cabling	9-35
9.10.8	DC Power Cabling	9-36
9.10.9	Computer Network Cabling	9-37
9.10.10	Optical Fiber Cabling	9-52
9.10.11	RF Cabling	9-54
9.10.12	Antenna System Analysis (Antenna System Commissioning)	9-58
9.10.13	Reuse of Existing RF Transmission Line	9-59
9.10.14	GPS Antenna Installation	9-59
9.10.15	Cabling in Telephone Wiring Environments	9-59
9.10.16	Distribution Frame Configurations	9-60
9.10.17	Cable Labeling	9-62
9.10.18	Outdoor Equipment/Cable Installation	9-63
9.11	Tower Lighting Systems	9-65
9.12	Equipment Removal	9-65
9.12.1	Equipment Removal Requirements	9-66
9.13	Site Security Surveillance Systems	9-67
9.14	Utility Pole-Mounted Equipment Installation and Clearances	9-68
9.14.1	Utility Pole Required Clearances	9-68
9.15	Electrostatic Discharge Considerations	9-72

Appendix A. Electromagnetic Energy (EME) Information

A.1	Introduction	A-1
A.2	Environmental Evaluation	A-2

A.2.1	Exposure Standards and Limits	A-2
A.2.2	Compliance Analysis	A-3
A.2.3	Exposure Evaluation	A-4
A.2.4	EME Zoning	A-7
A.2.5	Characterization Zoning	A-8
A.3	Engineering Considerations	A-10
A.3.1	Antenna Elevation	A-10
A.3.2	Extending Antennas Away From Towers	A-11
A.3.3	Collocated Broadcast Transmitters	A-11
A.3.4	Location of Directional Antennas	A-11
A.3.5	Antenna Selection	A-11
A.3.6	Mounting Density of Antennas	A-12
A.3.7	Uptime	A-12
A.3.8	Antenna Site Documentation	A-13
A.4	Work Practices	A-14
A.4.1	Training and Qualification Verification	A-14
A.4.2	Physical Access Control	A-14
A.4.3	Policing	A-14
A.4.4	Chain of Authority and Reporting Requirements	A-14
A.4.5	Understanding Site Responsibilities Under Shared Conditions	A-14
A.4.6	General Procedures	A-15
A.4.7	Site Specific Procedures	A-16
A.4.8	Operating Procedures	A-16
A.5	Signage	A-17
A.6	Personal Protective Equipment (PPE)	A-20
A.6.1	Protective Clothing	A-20
A.6.2	Personal Monitors	A-21
A.7	EME Action Thresholds Summary	A-21

Appendix B. Soil Resistivity Measurements

B.1	Safety	B-1
B.2	Soil Resistivity Variability and Factors Affecting Soil Resistivity	B-2
B.3	Testing Methods	B-5
B.4	Site Preparation Considerations	B-6
B.4.1	Required Test Equipment and Supplies	B-6
B.4.2	Performing Soil Resistivity Test	B-6
B.4.3	Interpreting Test Results	B-11

Appendix C. Protecting Against Electrostatic Discharge in Equipment Rooms and Dispatch Centers

C.1	Background Information	C-1
C.2	Equipment Handling and Storage	C-1
C.3	Measures for Controlling Electrostatic Discharge	C-2
C.3.1	Wrist-Straps	C-2
C.3.2	Relative Humidity Control	C-2
C.3.3	Flooring	C-3
C.3.4	Chairs	C-3
C.3.5	Dispatch Position Desktops	C-3
C.3.6	Video Display Terminals	C-4
C.3.7	Equipment Bonding, Grounding and Surge Protection	C-4

C.4 ESD Control ProgramC-4

Appendix D. Grounding (Earthing) Electrode System Testing/Verification and Bonding Continuity Testing/Verification

D.1 SafetyD-1
 D.2 OverviewD-2
 D.2.1 Fall-of-Potential TestingD-2
 D.2.2 Clamp-on Ground Resistance Test (also known as Clamp-on Ohmmeter Test)D-2
 D.2.3 Combined Soil Resistivity Testing with Clamp-on Ohmmeter TestingD-2
 D.3 Prerequisites for TestingD-3
 D.3.1 Fall-of-Potential TestD-3
 D.3.2 Clamp-on Ground Resistance TestD-3
 D.3.3 Combined Soil Resistivity and Clamp-on Ohmmeter TestD-3
 D.3.4 Testing Prerequisites Not MetD-4
 D.4 Fall-of-Potential Testing ProcedureD-5
 D.4.1 Test Description and TheoryD-5
 D.4.2 Required Test Equipment and SuppliesD-6
 D.4.3 Preparation for TestingD-7
 D.5 Clamp-On Ohmmeter Testing ProcedureD-18
 D.5.1 Test DescriptionD-19
 D.5.2 Required Test Equipment and SuppliesD-21
 D.5.3 Preparations for TestingD-21
 D.5.4 Clamp-on Ohmmeter Bonding Continuity TestingD-28
 D.6 Combining Soil Resistivity Testing with Clamp-On OhmmeterD-29

Appendix E. General Conversions and Formulas

Appendix F. R56 Compliance Checklist

F.1 Building Design and InstallationF-1
 F.2 External Grounding (Earthing) and Bonding SystemF-1
 F.3 Internal Bonding and Grounding SystemF-3
 F.4 Power SourcesF-4
 F.5 Surge Protective Devices (SPD)F-5
 F.6 Equipment InstallationF-5

Appendix G. Mobile Installation Standards and Techniques

G.1 IntroductionG-1
 G.2 Referenced Publications for Mobile InstallationG-2
 G.3 Safety Requirements for Mobile InstallationG-2
 G.4 Mobile Installer Training and CertificationG-3
 G.5 Planning for Mobile InstallationG-4
 G.5.1 Vehicle ProtectionG-5
 G.6 Transceiver Preventative Maintenance and InspectionG-5
 G.7 Pre-Install and Post-Install ChecklistG-5
 G.8 Tools for Mobile InstallationG-6
 G.9 Installation of Mobile EquipmentG-7
 G.9.1 Mounting Systems for Mobile ElectronicsG-8
 G.9.2 Securing Hardware for Mobile InstallationG-10
 G.9.3 Routing, Protection and Securing of Conductors and CablingG-11

G.9.4 Cable Labeling for Mobile Installation	G-12
G.9.5 Speaker Installation	G-13
G.9.6 Microphone Installation	G-13
G.9.7 Equipment Installation in Vehicles with Airbags	G-13
G.10 Power Wiring for Mobile Installation	G-14
G.10.1 Power Conductors for Mobile Installation	G-17
G.11 Joining Conductors for Mobile Installation	G-23
G.11.1 Electrical Ring Terminals, Lugs, Splices, and Similar Devices	G-24
G.11.2 Bonding Requirements for Mobile Installation	G-27
G.11.3 Conductor Tapping and Soldering	G-27
G.11.4 Electrical Tape and Heat Shrink Tubing	G-28
G.12 Antenna Installation and Testing	G-30
G.12.1 Coaxial Cable (Coax)	G-30
G.12.2 Antenna Installation	G-30
G.12.3 Antenna Installations on Non-Metallic Surfaces	G-32
G.12.4 Mini-UHF Connection	G-34
G.12.5 Antenna VSWR Testing	G-37
G.13 Effective Receiver Sensitivity Testing	G-38
G.14 Radio Transmit Noise Testing	G-41
G.15 Installation of Miscellaneous Equipment	G-43
G.15.1 Power and Ground Sources	G-43
G.15.2 Relays	G-43
G.15.3 Sirens	G-44
G.15.4 Strobe Lights	G-45
G.16 Motorcycle Installations	G-45
G.17 Marine Installations	G-46
G.18 Aircraft Installations	G-48
G.19 Example of Installation Checklist	G-48

THIS PAGE INTENTIONALLY LEFT BLANK.

This manual provides Motorola Solutions' requirements and guidelines for the installation of communications equipment, infrastructure and facilities. This manual is primarily based on recognized industry codes and standards. This edition of the manual has been updated to reflect recent changes to industry codes and standards referenced throughout the manual.



NOTE

The requirements and recommendations in this manual revision **shall** apply to new communication sites built after the manual publication date. Sites built prior to publication of this revision are not required to be upgraded. New equipment installations into existing sites **shall** comply with this revision as much as practicable.

Users of this manual are cautioned to read and understand all disclaimers on the inside front cover before using this manual.

1.1 R56 Rewrite Committee Members

While many have contributed to the R56 manual over the years, the following committee members contributed the majority of the efforts to the update of this manual, which is a publication of the Motorola Solutions Learning organization. Each committee member has extensive experience and technical expertise in one or more of the included topics.

Motorola Solutions	
Shane Morris, BSEET, CETma Rewrite Technical Lead Rewrite Project Manager Technical Support Manager	Blake Smith, CBC Rewrite Construction Lead Rewrite Project Manager National Site Design and Integration Team
Ron Tatom, CETsr R56 Auditor Specialist	Chris Hoch, CETma Technical Support Manager
Dan Gilliland, CETma Associate Contributor	Ron Taylor, CETma Associate Contributor
Motorola Solutions Partners	
Mark Harger Keith Olson, Graphics Designer (rendered graphics) Harger Lightning & Grounding Grayslake, IL, USA www.harger.com	Lyncole XIT Grounding Torrance, CA, USA www.lyncole.com
Transtector / PolyPhaser / Smiths Microwave Hayden, ID, USA www.transtector.com www.PolyPhaser.com https://www.smithsinterconnect.com/business-units/microwave	Reid Harlocker, BSES, CETsr Critical Systems Consulting Group Sam Chreiteh, BSEE

To contact the committee with questions about this manual or to offer suggestions for improving this manual, send email to: R56man1@motorolasolutions.com.

For R56 technical questions and/or consulting, please contact your local Motorola Solutions representative.

1.2 Organization of This Manual

This manual is organized into chapters, each of which provides requirements and guidelines for a major aspect of site development. Each chapter contains the following information about the subject it covers:

- Requirements that must be followed. Requirements are indicated by the use of the word “**shall**” in boldface type.
- Guidelines that describe preferred methods, but which are not requirements. Guidelines and recommendations are indicated by the use of the word “should.”
- Useful information about planning, designing and developing communications sites.

This manual is a living document. The following website will be used to publish manual updates and/or corrections: <https://businessonline.motorolasolutions.com>

After accessing the web site, perform the following steps:

1. Log into Motorola Online (MOL)
2. Click on **Resource Center**
3. Click on **Product Information**
4. Click on **Literature**
5. Click on **R56 Manual Updates**

1.3 General Statements

General statements included in this manual alert you to important and noteworthy information. General statements in this manual are of the following types:



IMPORTANT

Important notes help identify information of importance.



NOTE

Notes provide information that makes the job or process easier to perform properly.

1.4 Safety Information

The following sections describe how safety information is presented in this manual.

1.4.1 Safety Statements Defined

Safety statements included in this manual alert you to potential hazards to personnel or equipment and precede the step or text to which they apply. Safety statements in this manual are of the following types:

**WARNING**

Warnings indicate danger of injury or death to personnel. Warnings can indicate chemical, electrical or other types of hazards. Warnings are indicated by an exclamation point and the word **WARNING**.

**CAUTION**

Cautions indicate the possibility of damage to equipment. Cautions are indicated by an exclamation point and the word **CAUTION**.

1.4.2 General Safety Guidelines

The following are general safety precautions that must be observed:

**WARNING**

All Motorola Solutions employees and contractors and other personnel shall be required to use an appropriate EME monitoring device when working in the vicinity of fixed transmission sources of RF energy, unless they are able to conclude clearly that RF energy levels where they are working do not exceed those permitted by applicable standards and regulations. See Appendix A for additional information.

- All Motorola Solutions employees, contractors and other personnel working at communication sites **shall** be familiar with the information contained in this manual and **shall** follow the appropriate requirements and guidelines.
- To avoid injury or death caused by electric shock, do not wear a grounded wrist strap when working with high-voltage equipment.
- Objects heavier than 18.2 kg (40 lb.) should be lifted by two or more people.
- Before disturbing the surfaces in an existing structure, ensure that asbestos is not present. Surfaces containing asbestos can result in an inhalation hazard when disturbed by drilling, cutting, sanding or demolition. Only certified asbestos abatement professionals **shall** perform asbestos removal. A certificate of occupancy **shall** be secured where such abatement has been performed.
- Personnel performing installation and maintenance should wash their hands before eating and avoid touching mouth and nose while handling equipment and/or debris.
- In environments where explosion hazards may exist, non-incendive intrinsically safe electrical components **shall** be used. Note that certain locations may be entirely unacceptable for housing electronic equipment.
- Communications equipment **shall not** be installed in elevator equipment rooms unless specific, code-allowed measures have been taken to mechanically isolate any wiring from moving equipment.
- All applicable health and safety codes **shall** be followed when performing tasks discussed in this manual.
- Climbing of ladders and towers poses significant safety risks. Only personnel trained in this practice and who possess the proper equipment **shall** perform such work. The Motorola Solutions Contractors Fall Protection Program **shall** be observed.
- Utility locator services **shall** be used to locate buried utilities before conducting any subsurface explorations.
- To ensure personnel safety, all excavations **shall** be conducted in accordance with OSHA safety and excavation regulations and/or local safety regulations (whichever is more stringent).
- The fire department **shall** be notified as soon as a fire is discovered. Notification **shall not** be delayed in order to assess the results of fire fighting effort using on-site portable fire extinguishers.

**WARNING**

Do not sweep dry floors when rodent droppings are evident. To prevent hantavirus infection, the floor **SHALL** be mopped in a safe and sanitary manner using a 5:1 water/bleach mixture. Personnel working at the site **SHALL** wash hands before eating and avoid touching mouth, nose or eyes until site is sufficiently clean.

**WARNING**

When operating any kind of power tool, always wear appropriate safety glasses and other protective gear to prevent injury.

- In the United States:
 - all applicable OSHA standards **shall** be adhered to.
 - Ladders **shall** be OSHA approved for electrical work.
 - In installations at nuclear power plants and fuel processing facilities, the laws, rules and regulations of the Nuclear Regulatory Commission (NRC) policy and customer policy **shall** be observed.

1.5 Standards

Table 1-1 lists all published standards cited throughout this manual. All local and jurisdictional codes and safety standards, whether incidental or superseding to standards specified in this manual, **shall** be followed while developing a site, installing equipment or performing maintenance.

Table 1-1 REFERENCED STANDARDS

Publication	Title
ANSI A10.14	Requirements for Safety Belts, Harnesses, Lanyards and Lifelines for Construction and Demolition Use
ANSI A14	Requirements for Ladders
ANSI C62.1	Surge Arrestors For AC Power Circuits
ANSI/ESD S1.1	Wrist Straps
ANSI/ESD S4.1	Worksurfaces - Resistance Measurements
ANSI/ESD S20.20	Protection of Electrical and Electronic Parts, Assemblies and Equipment (Excluding Electrically Initiated Explosive Devices)
ANSI/ESD STM7.1	Floor materials—Resistive characterization of materials
ANSI/ESD STM12.1	Seating - Resistance Measurement
ANSI/ESD STM97.1	Floor Materials and Footwear—Resistance in Combination with a Person
ANSI Z308.1	Minimum Requirements For Workplace First Aid Kits
ANSI Z359	Fall Protection Code

Table 1-1 REFERENCED STANDARDS (CONTINUED)

Publication	Title
ANSI Z87.1	Occupational And Educational Eye And Face Protection
ANSI Z89.1	Industrial Head Protection
ANSI/IEEE C95.1	IEEE Standard for Safety Levels with Respect to Human Exposure to Radio Frequency Electromagnetic Fields,3 kHz to 300 GHz
ANSI/TIA-568-C	Commercial Building Telecommunications Cabling Standard
ANSI/TIA-569-C	Telecommunications Pathways and Spaces
ANSI/TIA-606-B	Administration Standard for Telecommunications Infrastructure
ANSI/TIA-607-C	Generic Telecommunications Bonding and Grounding (Earthing) for Customer Premises
ANSI/UL 154	Carbon-dioxide Fire Extinguishers
ANSI/UL 299	Dry Chemical Fire Extinguishers
ANSI/UL 711, CAN/ULC-S508-M90	Rating And Fire Testing of Fire Extinguishers
ANSI Z308.1	Minimum Requirements for Workplace First Aid Kits and Supplies
ANSI Z535.3	Criteria for Safety Symbols
AS 3516.2-1998	Siting of Radiocommunications Facilities – Guidelines for Fixed, Mobile and Broadcasting Services Operating At Frequencies Above 30 MHz
ASHRAE	American Society of Heating, Refrigerating and Air-Conditioning Engineers
AS/NZS 5070.1:2008	Siting and Operation of Radiocommunication Facilities
ASTM 488-90	Seismic Anchoring
ASTM A615 / A615M	Specifications for Deformed and Plain Carbon-Steel Bars for Concrete Reinforcement
ASTM C150	Standard Specification for Portland Cement
ASTM D1557	Test Method for Laboratory Compaction Characteristics of Soil Using Modified Effort
ASTM D698	Test Method for Laboratory Compaction Characteristics of Soil Using Standard Effort
ATIS-0600036.2016	Electrical Protection for Ethernet Systems
ATIS-0600311.2007	DC Power Systems - Telecommunications Environment Protection
ATIS-0600313.2013	Electrical Protection for Telecommunications Central Offices and Similar Type Facilities
ATIS-0600321.2015	Electrical Protection for Network Operator-Type Equipment Positions
ATIS-0600333.2013	Grounding and Bonding of Telecommunications Equipment
ATIS-0600334.2013	Electrical Protection of Communications Towers and Associated Structures
Bellcore Technical Specifications AU-434	Earthquake concrete expansion anchors

Table 1-1 REFERENCED STANDARDS (CONTINUED)

Publication	Title
Bellcore TR-64	Concrete Specifications for Seismic Installations
BOCA	Building Officials and Code Administrators
BS EN/IEC 62305:2011	Protection Against Lightning
BS 6651:1999	Code of Practice for Protection of Structures Against Lightning
BS 7430:2011	Code of Practice for Earthing
CAN4-S503-M83	Canadian Standard: Standard for Carbon Dioxide Hand and Wheeled Fire Extinguishers
CAN/CSA-B72-M87:2013	Canadian Standard: Installation Code for Lightning Protection Systems
CAN4/ULC-S504-12	Canadian Standard: Standard for Dry Chemical Fire Extinguishers
C22.1-15	Canadian Electrical Code, Part 1
CSA C22.2 No. 41-07	Grounding and Bonding Equipment
CSA-T529	Design Guidelines for Telecommunications Wiring Systems in Commercial Buildings, 1995 (harmonized with ANSI/TIA/EIA 569-A)
Code of Federal Regulations 47	Part 17 - Construction, Marking and Lighting of Antenna Structures
ETSI EN 300 253	Environmental Engineering (EE); Earthing and Bonding Configuration Inside Telecommunications Centres
FAA Advisory Circular 70/7460-1G	Obstruction Marking and Lighting
FAA-STD-019e	Lightning and Surge Protection, Grounding, Bonding and Shielding Requirements for Facilities and Electronic Equipment
FCC/OET RTA 95-01 (NTIS order no. PB95-253829)	Engineering Services for Measurement and Analysis of Radio Frequency (RF) Fields. Technical report for the Federal Communication Commission, Office of Engineering and Technology, Washington, DC
FCS1362:2010	UK Code of Practice for the Installation of Mobile Radio and Related Ancillary Equipment in Land Based Vehicles
FEMA 413	Installing Seismic Restraints for Electrical Equipment
GR-63-CORE	Telcordia® NEBS™ Requirements: Physical Protection
GR-1275-CORE	Telcordia® Central Office Environment Installation/Removal Generic Requirements
IBC 2015	International Building Code
IEC 60364-1:2005	Low-voltage electrical installations
IEC 60364-5-54:2011	Low-voltage electrical installations - Part 5-54: Selection and Erection of Electrical Equipment - Earthing Arrangements and Protective Conductors
IEC 60529	Degrees of Protection Provided by Enclosures (IP Code)
IEC 60950-1	Information Technology Equipment - Safety - Part 1: General Requirements

Table 1-1 REFERENCED STANDARDS (CONTINUED)

Publication	Title
IEC 61024-1-2	Protection of Structures Against Lightning
IEC 62037-1	Passive RF and microwave devices, intermodulation level measurement - Part 1: General requirements and measuring methods
IEC 62305-3:2010	Protection Against Lightning
IEEE C62.41	IEEE Recommended Practice on Surge Voltages in Low-Voltage AC Power Circuits
IEEE C62.45	Guide on Surge Testing for Equipment Connected to Low-Voltage AC Power Circuits
IEEE C95	IEEE Standard for Safety Levels with Respect to Human Exposure to Radio Frequency Electromagnetic Fields, 3 kHz to 300 GHz
IEEE STD 80-2000	Guide for Safety in AC Substation Grounding
IEEE 81-2012	Guide for Measuring Earth Resistivity, Ground Impedance and Earth Surface Potentials of a Grounding System
IEEE STD 142-2007 (IEEE Green Book)	Recommended Practice for Grounding of Industrial and Commercial Power Systems
IEEE STD 519-2014	Recommended Practices and Requirements for Harmonic Control in Electrical Power Systems
IEEE 837	Qualifying Permanent Connections Used in Substation Grounding
IEEE 1100-2005 (IEEE Emerald Book)	Recommended Practice for Powering and Grounding Electronic Equipment
IEEE 1159-2009	Recommended Practice for Monitoring Electric Power Quality
IEEE 1692-2011	Guide for the Protection of Communication Installations from Lightning Effects
ISO 11271:2002	Soil quality – Determination of Redox Potential – Field Method
ISO/TC94/SC4	Personal Equipment for Protection Against Falls (International ISO standard)
International Telecommunication Union (ITU)	Earthing and Bonding Handbook
MIL-HDBK-419A	Grounding, Bonding and Shielding for Electronic Equipments and Facilities
MIL-STD-188-124B	Grounding, Bonding and Shielding for Common Long Haul/Tactical Communications Systems Including Ground Based Communications Electronic Facilities and Equipments
MIL-STD-188-125-1	High-altitude Electromagnetic Pulse (HEMP) Protection for Ground-based C41 Facilities Performing Critical, Time-Urgent Missions, Part 1 Fixed Facilities
Motorola document 68P09226A18	Frame Mounting Guide
Motorola document 68P81150E62	Grounding Guideline for Cellular Radio Installations
NECA/BICSI 568-2006	Installing Commercial Building Telecommunications Cabling
NECA/BICSI 607-2011	Standard for Telecommunications Bonding and Grounding Planning and Installation Methods for Commercial Buildings
NEMA	National Electrical Manufacturers Association

Table 1-1 REFERENCED STANDARDS (CONTINUED)

Publication	Title
NFPA 1	Fire Code
NFPA 10	Standard for Portable Fire Extinguishers
NFPA 12	Standard for Carbon Dioxide Extinguishing Systems
NFPA 13	Standard for Installation of Sprinkler Systems
NFPA 17	Standard for Dry Chemical Extinguishing System
NFPA 33	Standard for Spray Application Using Flammable or Combustible Materials
NFPA 70	National Electrical Code® & International Electrical Code® Series
NFPA 70E	Standard for Electrical Safety in the Workplace
NFPA 101®	Life Safety Code®
NFPA 111	Standard on Stored Electrical Energy, Emergency and Standby Power Systems
NFPA 780	Standard for the Installation of Lightning Protection Systems
NFPA 2001	Standard on Clean Agent Fire Extinguishing Systems
NWSM 30-4106	Lighting Protection, Grounding, Bonding, Shielding and Surge Protection Requirements
OSHA 1926.104	Safety Equipment
STM97.1	Floor Materials and Footwear - Resistance Measurement in Combination with a Person
Telcordia® GR-63-CORE	NEBS Requirements: Physical Protection
Telcordia® GR-487, Issue 5	Generic Requirements for Electronic Cabinet
Telcordia® GR-1089	Electromagnetic Compatibility and Electrical Safety - Generic Criteria for Network Telecommunications Equipment
Telcordia® GR 1275	Central Office/Network Environment Equipment Installation/Removal Generic Requirements
Telcordia® GR-3171-CORE	Generic Requirements for Network Elements Used in Wireless Networks Physical Layer Criteria
TIA-222	Structural Standard for Antenna Supporting Structures and Antennas
TIA-568-C	Commercial Building Telecommunications Cabling Standard
TIA-569-C	Telecommunications Pathways and Spaces
TIA-606-B	Administration Standard for Telecommunications Infrastructure
TIA-607-C	Generic Telecommunications Bonding and Grounding (Earthing) for Customer Premises

Table 1-1 REFERENCED STANDARDS (CONTINUED)

Publication	Title
UBC Articles 2330 through 2338 Article 1807 (c), (k), Chapter 23 Article 2370	Uniform Building Code Earthquake, Seismic Designs High-Rise Buildings Seismic Isolated Structure Design
UL 154	Carbon Dioxide Extinguishers
UL 299	Dry Chemical Extinguishers
UL 268	Smoke Detectors for Fire Alarm Systems
UL 467	Grounding and Bonding Equipment
UL 497A	Secondary Protectors For Communication Circuits
UL 497B	Protectors for Data Communication and Fire Alarm Circuits
UL 497C	Standard for Protectors for Coaxial Communications Circuits
UL 891	Switchboards
UL 1449 4th Edition	Standard for Surge Protective Devices
United States National Weather Service Manual 30-4106-2004	Lightning Protection, Grounding, Bonding, Shielding and Surge Protection Requirements
ZED 259	Requirements for Personal Fall Arrest Systems (Canadian standard)

1.5.1 Australia and New Zealand Standards

The following standards publications are applicable for communication sites constructed in Australia and New Zealand.

Table 1-2 AUSTRALIAN AND NEW ZEALAND STANDARDS

Publication	Title and Description
ARPANSA RSP 3	Maximum Exposure Levels to Radio Frequency Fields - 3 kHz to 300 GHz Sets limits for human exposure to radio frequency (RF) fields in the frequency range 3 kHz to 300 GHz. The Standard includes: mandatory basic restrictions for both occupational and general public exposure involving all or part of the human body; indicative reference levels for measurable quantities derived from the basic restrictions; approaches for verification of compliance with the Standard; requirements for management of risk in occupational exposure and measures for protection of the general public.
AS/CA S008:2010	Requirements for Authorised Cabling Products
AS/CA S009:2013	Installation Requirements for Customer Cabling (Wiring Rules)

Table 1-2 AUSTRALIAN AND NEW ZEALAND STANDARDS (CONTINUED)

Publication	Title and Description
AS/NZS 1170.1	<p>Structural Design Actions - Permanent, Imposed and Other Actions</p> <p>Provides design values of permanent, imposed and other actions to be used in the limit state design of structures and members. It is intended to be used in conjunction with AS/NZS 1170.0. Other actions covered include liquid pressure, ground water, rain water ponding and earth pressure.</p>
AS/NZS 1170.2	<p>Structural Design Actions - Wind Actions</p> <p>Provides design values of wind actions for use in structural design. It is intended to be used in conjunction with AS/NZS 1170.0, which gives the procedure for structural design. Wind speeds and direction factors are provided for a range of probabilities of exceedance. Other factors cover the environment around the structure, the geometry of the structure and the dynamic interaction of the structure with the wind.</p>
AS 1319	<p>Safety Signs for the Occupational Environment</p> <p>Specifies the requirements for the design and use of safety signs intended for use in the occupational environment to regulate and control safety related behavior, to warn of hazards and to provide emergency information including fire protection information.</p>
AS/NZS 1554 (Set)	Structural Steel Welding Set
AS/NZS 1680.2.4	<p>Interior Lighting - Industrial Tasks and Processes</p> <p>Sets out recommendations for the lighting of industrial tasks and processes with a view to providing visual environments in which such tasks and processes may be safely and efficiently performed. It is intended to be read in conjunction with the general recommendations of AS 1680.1.</p>
AS/NZS 1768	Lightning Protection
AS 2032	Code of Practice for Installation of UPVC Pipe Systems
AS/NZS 2053.1	<p>Conduits and Fittings for Electrical Installations - General Requirements</p> <p>Specifies general requirements for both metal and non-metal conduits and fittings to protect cables used in electrical installations. Mechanical properties, electrical characteristics and material requirements are given. Requirements for particular types of conduits and fittings are covered in the other parts of the AS/NZS 2053 series.</p>
AS/NZS 2293.1	<p>Emergency Evacuation Lighting for Buildings - System Design, Installation and Operation</p> <p>Sets out requirements for the design, installation and operation of electric emergency evacuation lighting systems for buildings, so as to provide visual conditions which will alleviate panic and permit safe evacuation of the building's occupants, should this be necessary, in the event of failure of the electrical supply to the normal lighting. Does not specify types of buildings nor particular locations which should be provided with emergency evacuation lighting.</p>
AS 2444	Portable Fire Extinguishers and Fire Blankets - Selection and Location
AS/NZS 3000	<p>Electrical installations (known as the Australian/New Zealand Wiring Rules)</p> <p>Provides requirements for the selection and installation of electrical equipment, design and testing of electrical installations, especially with regard to the essential requirements for safety of persons and livestock from physical injury, fire or electric shock.</p>

Table 1-2 AUSTRALIAN AND NEW ZEALAND STANDARDS (CONTINUED)

Publication	Title and Description
AS/NZS 5070.2:2008	<p>Siting and Operation of Radiocommunications Facilities - Guidelines for Siting of Radiocommunications Facilities: VHF, UHF and SHF</p> <p>Recommends good practice for and sets out process by which, radio communications sites should be planned, sited, constructed and operated to meet the communications objectives of those facilities. It particularly addresses the sharing of radio communications sites and interference problems which could arise. It is intended to provide information to Federal, State and local government authorities, facilities planners, site planners, organizations and members of the public on the effects that existing or planned developments could be expected to have on the operation of such facilities and vice versa.</p>
AS/NZS 60950:2000	<p>Safety Requirements for Customer Equipment</p> <p>Defines the safety requirements for Customer Equipment (CE) with the objective of providing protection of the CE users from electrical supply hazards, protection of the CE user from telecommunications network hazards, protection of telecommunications network personnel from connected CE hazards and protection of a telecommunications network from harm arising from connected CE (both mains powered and non-mains powered).</p>
AS 3600	<p>Concrete Structures</p> <p>Sets out minimum requirements for the analysis, design and construction of concrete structures and members that contain reinforcing steel up to 500 MPa, prestressing tendons or both, and includes requirements for plain concrete structures and members. Design requirements are given for the limit states of stability, strength, serviceability, durability and for resistance requirements to fire and earthquakes. Rules are also given for prototype or proof testing of finished members and structures.</p>
AS 3610	Formwork for Concrete
AS 3995	Design of Steel Lattice Towers and Masts
AS 4100	<p>Steel Structures</p> <p>Sets out minimum requirement for the design, fabrication, erection and modification of steelwork in structures in accordance with the limit states design method.</p>
AS/NZS 4117	Surge Protective Devices for Telecommunication Applications
AS/NZS 4680	Hot-dip Galvanized (Zinc) Coatings on Fabricated Ferrous Articles
AS/NZS 60950.1:2015	<p>Safety of Information Technology Equipment (IEC 60950-1, Ed. 2.2 (2013), MOD)</p> <p>Specifies requirements for the safety of information technology equipment including electrical business equipment and associated equipment, with a rated voltage not exceeding 600V. Specifies requirements intended to ensure safety for the operator and layman who may come into contact with the equipment and, where specifically stated, for service personnel. This Standard is an adoption with national modifications and has been reproduced from IEC 60950-1, Ed. 2.2 (2013).</p>
SAA HB37.4	Handbook of Australian Fire Standards - Building Materials, Products and Construction

1.5.2 Standards Organization Websites

Internet sites for some major regional standards organizations are listed for reference in the following table.

Country/Region	Website
Australia	www.standards.com.au
Britain	www.standardsuk.com
Canada	www.csagroup.org
China	en.cnis.gov.cn
Europe	www.etsi.org
France	www.afnor.fr
International:	www.iec.ch
	www.nfpa.org
	www.standards.ieee.org
	www.iso.org
	www.ul.com
Japan	www.jsa.or.jp
Malaysia	www.sirim.my
New Zealand	www.standards.co.nz
Singapore	www.spring.gov.sg
United States:	
• Alliance for Telecommunications Industry Solutions	www.atis.org
• American National Standards Institute	www.ansi.org
• Electrostatic Discharge Association	www.esda.org
• FCC Office of Engineering and Technology (RF safety)	www.fcc.gov/oet/rfsafety
• Telecommunications Industry Association	www.tiaonline.org
• United States Geological Survey Geological Hazards Team	geohazards.usgs.gov
• United States Geological Survey (Earthquake Hazards Program)	earthquake.usgs.gov
• United States Geological Survey home page	www.usgs.gov

1.6 Motorola Solutions R56 Support Services

Motorola Solutions provides the following R56 services:

- Training
- Site Design
- Installation
- R56 compliance audits using R56 certified auditors
- R56 certification
- R56 Forensics Analysis

See “Organization of This Manual” on page 1-2 for the location of updates to this manual.

1.7 Glossary

This section provides definitions of terms and acronyms used in this manual.

ACI: American Concrete Institute.

ACS: Advanced Conventional Systems.

ADSL: Asymmetric Digital Subscriber Line.

AEB: Ambassador Electronics Bank.

AH: Ampere Hours.

AHJ: Authority Having Jurisdiction.

Ambassador Electronics Bank: A central switch that routes and combines all audio sources for SmartZone trunking systems. Also known as Embassy Switch or AEB.

Ambient Temperature: Environmental temperature as typically measured 610 mm (5 ft) above the floor in the center of an aisle.

Ampere Hours: A measurement of battery current capacity relative to time, normalized to 8 hours. For example, a 320 Ah battery will deliver 40 Amperes for 8 hours.

ANSI: American National Standards Institute.

Antenna: A device that permits transmission and reception of radio frequency energy through space. Also known as aerial.

Antenna Structure: Generic term describing an antenna supporting system which may be other than a tower (building, monopole, bracket, and so on).

Approved: Acceptable to the Authority Having Jurisdiction.

As-Built: A Motorola Solutions factory-provided printout furnished with a new system or site development that describes the system's or sites original factory-built or installed configuration.

ASHRAE: American Society of Heating, Refrigerating and Air Conditioning Engineers.

ASSE: American Society of Safety Engineers.

ASTM: American Society for Testing of Materials.

Attenuator: A passive device for controlling (attenuating) signal levels. It can be fixed, calibrated or variable. Where calibrated attenuators are used, the device is typically calibrated in dB of negative gain (loss or attenuation).

Authority Having Jurisdiction (AHJ): An organization, office, or individual responsible for enforcing the requirements of a code or standard, or for approving equipment, materials, an installation, or a procedure. The local governing body. See NFPA 70-2017, Article 100, for more information.

AWG: American Wire Gauge: An American standard for identifying the thickness of electrical conductors.

Bandpass Cavity: A high Q resonant circuit designed to pass a narrow band of frequencies with very little loss while attenuating all other frequencies outside the selected bandwidth. Where used between a transmitter and the antenna transmission line, it reduces spurious signals and transmitter sideband noise that might otherwise be radiated from the transmitter and degrade the performance of a nearby receiver.

Bandwidth: The frequency spectrum space occupied by a signal of a single channel.

Base station: 1) Station that allows simplex communications between radio units and console positions. Also: A repeater which provides the source of audio received by the console and the destination of audio transmitted from the console.

Battery: One or more electrochemical storage cells connected together to serve as a DC voltage source.

Blackout: An extended zero-voltage condition (total loss of power) lasting for minutes, hours or even days at a time. Blackouts can be caused by ground faults, accidents, lightning strikes, power company failures or other acts.

BNC: Bayonet “N” Connector.

BOCA: Building Officials and Code Administrators International, Inc.

Bonding: The permanent joining of metallic parts to form an electrically conductive path that ensures electrical continuity and the capacity to safely conduct any current likely to be imposed.

Bonding jumper: A reliable conductor that ensures the required electrical conductivity between metal parts required to be electrically connected.

Boot: A protective, flexible sleeve installed around cables that pass through the wall of a communications site building.

Branch circuit: The circuit conductors between the final overcurrent device protecting the circuit and the outlet(s).

British Thermal Unit: A standard measurement of generated energy, typically as heat. (1 BTU equals 1.055 kJoules of energy.)

Brownout: A long-term under-voltage condition lasting minutes, hours or even days at a time. They are often intentionally instituted by an electric utility company when peak demand exceeds generating capacity.

BTU: British Thermal Unit.

Building: For the purposes of this manual, a permanent structure capable of regular human occupancy built on a foundation that contains communications equipment and related ancillary support systems and may contain other unrelated equipment and/or facilities.

Cabinet/enclosure: An enclosure that houses communications equipment and ancillary systems only. It is designed such that equipment contained within can be accessed without the need for personnel to enter the cabinet.

Cable ladder: An open steel structure (painted or anodized) suspended from the ceiling that provides an orderly means of support and routing for wires and cables throughout a communications site. May be installed inside the building or vertically to guide cables on a tower. All exterior cable ladders should be constructed of galvanized metal. See Cable runway.

Cable runway: A structure provided for the routing and management of cabling. May be located below a raised floor, suspended from the ceiling, or mounted on top of equipment racks and/or cabinets. The term Cable Runway is used in this manual to include both cable ladders and cable trays.

Cable tray: A solid structure, typically constructed of aluminum or fiberglass, suspended from the ceiling that provides an orderly means of support and routing for wires and cables throughout the interior of a communications site. See Cable runway.

Caisson: A drilled cylindrical foundation shaft used to transfer a load through soft soil strata to firm strata or bedrock. The shaft is filled with either reinforced or unreinforced concrete. A caisson may either be a straight shaft or bell type of installation.

CATV: Cable Television.

CCTV: Closed-Circuit Television.

CEB: Central Electronics Bank

Cellular: A multi-site, low-power full-duplex radio system that interfaces to the PSTN.

Central Electronics Bank: Electronic equipment that provides the interface between the console dispatch positions and the RF equipment (CEB).

- Central Office:** The main switching center of a telephone service provider or local exchange carrier (LEC).
- CEPT:** European Committee of Post and Telegraphs.
- CFC-free:** Denotes a refrigerant which does not use chlorofluorocarbons.
- CFR:** Code of Federal Regulations.
- Channel bank:** A device that places multiple channels on a digital or analog carrier signal.
- Channel Service Unit:** A digital DCE used to terminate digital circuits (such as DDS or T-1 lines) at the customer site. It conditions the line, ensures network compliance with FCC rules and responds to loopback commands from the central office.
- CIU:** Console Interface Unit.
- CO:** Central Office.
- Combiner:** A passive device that allows transmitters on different frequencies to use a single antenna.
- Communications Equipment:** The electronic equipment that performs the telecommunications operations for the transmission of audio, video and data, and includes power equipment (for example, DC converters, inverters, and batteries), technical support equipment (for example, computers), and conductors dedicated solely to the operation of the equipment.
- Communications Raceway:** An enclosed channel of nonmetallic materials designed expressly for holding communications wires and cables, typically communications wires and cables and optical fiber and data (Class 2 and Class 3) in plenum, riser and general-purpose applications.
- Console:** A system's dispatch electronics, made up of one or more console operator positions and a Central Electronics Bank (CEB).
- Console Interface Unit:** An interface device that provides encryption/ decryption of console audio signals.
- Conventional system:** A radio system in which resources are dedicated to a specific frequency.
- CPR:** Cardio-Pulmonary Resuscitation.
- Critical Loads:** Devices and equipment whose failure to operate satisfactorily jeopardizes the health or safety of personnel and /or results in loss of function, financial loss or damage to property deemed critical by the user.
- CSA:** 1) Canadian Standards Association. 2) Cross-sectional area (as used for cable gauge specification in metric system).
- CSI:** Construction Specification Institute.
- CSU:** Channel Service Unit.
- Daisy chain:** Any method of connection whereby the conductors are connected from one chassis, equipment frame or rack connection point to a second chassis, equipment frame or rack connection point and on to a third connection point, creating a series arrangement whereby the removal of the second connection point interrupts the ground path from the first chassis, equipment frame or rack. Daisy chaining of grounding conductors is not an acceptable method of connection.
- Demarcation Point:** The telephone or utility point of presence at a facility which divides utility assets from customer assets and accordingly assigns maintenance responsibilities.
- Dip:** See Sag. Dip is the International Electrotechnical Commission (IEC) term for sag.
- Distortion:** Any deviation from the normal sine wave for an AC quantity.
- DOT:** Department of Transportation.
- Duplexer:** An RF filtering system that separates the transmit and receive frequency, so that equipment can transmit and receive simultaneously on a single antenna, without affecting other equipment.
- DVM:** Digital Voltmeter.
- E-1:** A time division multiplex (TDM) digital link which uses 32 time slots with a speed of 2.048Mb/s
- Earth; Earthing:** Synonymous with ground; grounding.
- EAS:** Environmental Alarm System.
- Easement:** An interest in real property which is owned by another that entitles the holder to a specific limited use or enjoyment of the owner's property.

EBTS: Enhanced Base Transceiver System.

Effective Radiated Power: The near-field radiated effective power (as opposed to peak envelope power) of a transmitting antenna. Specifies power radiated less any losses inherent in transmission lines or antenna coupling.

EGB: External Ground Bus Bar.

EHS: Environmental Health and Safety.

EIA: Electronics Industries Association.

Electrolytic ground rods: Ground rods in which the ability to dissipate charge is enhanced by chemical reaction with the soil.

Electrical Metallic Tubing: Describes conduit tubing used specifically for housing electrical conductors. Several variations are available for specific purposes.

Electrostatic Discharge: A high voltage, low current electrical discharge caused by buildup of static charge between two surfaces.

EME: Electromagnetic Energy.

EMT: Electrical Metallic Tubing.

Enhanced Base Transceiver System: Base stations used in the iDEN system.

Environmental Alarm System: Equipment which centrally receives, interfaces and processes remote alarms related to equipment environmental conditions and other switch-closure alarms.

Equipotential: Having the same electric potential or uniform electric potential. The same or uniform potential at every point.

ERP: Effective Radiated Power.

ESD: Electrostatic Discharge.

Ethernet: A Local Area Network (LAN) protocol.

ETSI: European Telecommunications Standards Institute.

Exothermic welding: A process by which two pieces of metal are permanently welded using heat generated by a chemical reaction caused by combining the welding materials.

External Ground Bus Bar: A ground bus bar that provides a bonding point for multiple grounding conductors (such as all coaxial connections) and connection to the grounding electrode system.

External grounding system test: A test that measures the effective resistance of the external site grounding system.

External site grounding ring: A ring of conductor wire surrounding an equipment enclosure, building and tower at a communications site. The grounding ring is bonded to the grounding electrodes, so that electrical charges are ultimately dissipated by the earth.

FAA: Federal Aviation Administration.

Fair Market Value: The approximate worth of a piece of property, based on several factors including location and the actual selling price of similar properties in the area.

Facility: A complete site environment, including power system(s), site structure, HVAC system, antenna structure and boundary fencing (if applicable).

Failsoft: A default communication mode for trunking systems that prevents system shutdown by providing limited communications capability during a system failure. The repeaters operate in conventional mode if the central controller fails.

FCC: Federal Communications Commission.

Federal Aviation Administration: The US regulatory agency responsible for air traffic safety. It also governs height and marking regulations for towers and other tall structures that could pose a hazard to aircraft.

Federal Communications Commission: The US regulatory agency responsible for overseeing radiated transmissions in the United States.

- Firestop:** A cross-member used in walls to inhibit vertical spread of fire.
- Fixed Network Equipment:** Permanently installed communications site infrastructure equipment.
- FM:** Factory Mutual.
- FMV:** Fair Market Value.
- FNE:** Fixed Network Equipment.
- FOTS:** Fiber Optic Transmission System.
- Frequency Deviation:** An increase or decrease in the power frequency from nominal. The duration of a frequency deviation can be from several cycles to several hours (IEEE STD 1100-2005 and IEEE STD 1159-2009).
- FRU:** Field Replaceable Unit.
- GFCI:** Ground Fault Circuit Interrupting.
- Gin pole:** Construction equipment used for lifting tower sections and antennas during antenna construction.
- Global Positioning System (GPS):** A system which determines exact locations by utilizing high-precision satellite signals as its reference. The satellite signals can also be used as a timing reference.
- Ground Fault Circuit Interrupting (GFCI):** A type of electrical receptacle that removes power to the receptacle if a ground fault occurs in the equipment connected to the receptacle.
- Grounding:** The connecting of a particular leg of a circuit across multiple equipment of a power system in common. The common connection is then also electrically bonded to the soil. In this manner, the grounded portion of the circuit can serve as a common low-side connection across the system. Synonymous with earthing.
- Grounding conductor:** A means for bonding equipment to the site grounding electrode system.
- Grounding electrode system:** A buried system of ground conductors that provides a bonding point between soil grounding at the site and the neutral-ground connection of the incoming AC power. The site MGBB is bonded to this point.
- Ground loop:** A potentially detrimental loop formed when two or more points in an electrical system that are normally at ground potential are connected by a conducting path such that either or both points are not at the same ground potential.
- Ground test well:** A buried port that allows inspection of connections to the grounding electrode system.
- Gumbo:** A soil composed of fine-grain clays. When wet, the soil is highly plastic, very sticky and has a soapy appearance. When dried, it develops large shrinkage cracks.
- Hantavirus:** A potentially deadly airborne virus spread by rodents.
- Hard-wiring:** The practice of direct physical connection of wiring leads directly to a junction device. An example of hard-wiring is the connection of a device's AC line directly to a junction box without the use of a receptacle and line cord.
- Harmonic:** Regarding power lines, an abnormality in which distortion of the normal utility sine wave occurs. Harmonics can be transmitted back into an AC power line by non-linear loads such as switching power supplies and variable speed motors. If significant enough, harmonic conditions can cause overheating in step-down and three-phase load transformers and neutral conductors.
- Hazardous Material Identification System:** A labeling system for identifying the location of potentially hazardous materials.
- HAZMAT:** Hazardous Material(s).
- Hertz:** Frequency measurement unit abbreviated as Hz. One Hz equals one cycle per second.
- HMIS:** Hazardous Material Identification System.
- HVAC:** Heating, Ventilation and Air Conditioning equipment.
- Hz:** Hertz.
- ICBO:** International Conference of Building Officials.
- Ice bridge:** A protective shield for horizontal cable runs between towers and building cable entry ports or between two buildings, designed to prevent ice from forming and falling on the cables during winter.

IDEN: Integrated Dispatch Enhanced Network.

IEC: International Electrotechnical Commission

IEEE: Institute of Electrical and Electronics Engineers.

IGZ: Isolated Ground Zone.

Integrated Dispatch Enhanced Network: A Motorola Solutions-manufactured digital transmit/receive system, operating in the 800-900 MHz range, that combines radio and telephone services in a single subscriber unit.

Intermodulation (IM): A The production, in a nonlinear element of a system (for example, amplifier), of frequencies corresponding to the sum and difference frequencies of the fundamentals and integral multiples (harmonics) of the component frequencies that are transmitted through the element (see *Newton's Telecom Dictionary*).

Internal Perimeter Bonding Bus (IPBB): A The IPBB, formerly known as the Internal Perimeter Ground (Earth) Bus (IPGB), conductors provide a suitable bonding conductor to earth for ancillary support apparatus, electrical conduits, ventilation louvers, metal door frames, and other metallic items (for example, non-electronic items) that are located throughout the shelter, building, or room.

IPBB: Internal Perimeter Bonding Bus conductor.

Isolated Ground Zone: An installation configuration where grounding of equipment is electrically isolated and/or separate from general facility grounding.

ITU: International Telecommunications Union. Also known as CCITT.

IZGB: Isolated Zone Ground Bar.

Labeled: Equipment or materials to which has been attached a label, symbol or other identifying mark of an organization that is acceptable to the Authority Having Jurisdiction and concerned with product evaluation, that maintains periodic inspection of production of labeled equipment or materials and by whose labeling the manufacturer indicates compliance with appropriate standards or performance in a specified manner.

Let-through Voltage: Voltage (at a specified current) allowed through a TVSS device when the device is in suppression mode.

Listed: Equipment, materials or services included in a list published by an organization that is acceptable to the Authority Having Jurisdiction and concerned with evaluation of products or services, that maintains periodic inspection of production of listed equipment or materials or periodic evaluation of services and whose listing states that either the equipment, material or service meets appropriate designated standards or has been tested and found suitable for a specified purpose.

Low Pass Filter: Also referred to as “harmonic filter”. Filter that suppresses harmonic frequencies above its specified pass band. It is used with transmitters to prevent intermodulation. Most systems require this type of filter between the isolator and the antenna system to reject second and third harmonic transmitter energy.

LPG: Liquefied Propane Gas.

LTV: Let-through Voltage.

LVLVD: Low-Voltage Load Disconnect.

Master Ground Bus Bar: The single grounding point inside an equipment enclosure to which all other interior ground wires are ultimately bonded. There is one master ground bus bar per building or equipment area at a communications site. See Primary Bonding Bar (PBB).

Material Safety Data Sheet: A manufacturer-provided ingredient and safety hazard description of materials classified as hazardous or containing hazardous elements. It also includes information for handling spills or chemical reactions.

Maximum Permissible Exposure: Defines maximum permissible exposure to radiated RF energy to personnel. Several levels exist based upon frequency, power density and time of exposure.

Metal-Oxide Varistor: A two-terminal voltage protection device in which resistance across the device markedly decreases when the voltage across the device reaches a specified threshold.

Meter pedestal: The base structure for the electric services utility meter at communications site. Typically installed by the local utility company during communications facility construction.

MGB: Master Ground Bus Bar.

Microwave: Frequencies higher than one GigaHertz (1,000,000,000 Hz) in the frequency spectrum.

Mobile Switching Office: Provides central office functions for iDEN mobile units.

Modified Proctor test: A soil compression test that measures the compacted density of soils being used for structural applications. See ASTM D1557 for additional information.

MOV: Metal-Oxide Varistor.

MPE: Maximum Permissible Exposure.

MSDS: Material Safety Data Sheet.

MSO: Mobile Switching Office.

MTBF: Mean Time Between Failures.

Multicoupler: An RF device which provides multiple outputs of a single RF input.

Multimeter: A test instrument capable of measuring voltage, current and resistance.

National Electrical Code: A consultative organization responsible for electrical practices standards. It is part of the National Fire Protection Association (NFPA).

NBB: Network-Equipment Bonding Bar

NEBS: Network Equipment Building Systems.

NEC®: National Electrical Code®.

Network-Equipment Bonding Bar (NBB): A bonding bar termination point for network equipment in a cabinet or rack. The purpose of an NBB is to provide a convenient bonding termination point for two or more similar pieces of network equipment installed adjacent to one another (horizontally or vertically) within the same cabinet or rack.

Network Interface Unit: A T-1 network interface unit.

NCRP: National Council for Radio Protection and Measurement.

NEMA: National Electrical Manufacturers Association.

NFPA: National Fire Protection Association.

NIU: Network Interface Unit.

Noise: Regarding line power, a power line abnormality which collectively refers to various kinds of high frequency impulses that ride on the normal sine wave of AC electrical power. Noise can range from a few millivolts to several volts in amplitude and can create erratic behavior in any electronic circuit. RF noise, when present over power lines, is one of the more troublesome. This noise can be generated by lightning, radio transmissions or computer power supplies.

Nomograph: An arrangement of axes in which a variable is determined by a line which intersects known points on associated axes.

Non-Linear Load: Steady-state electrical load that draws current discontinuously or whose impedance varies throughout the cycle of the input AC voltage waveform (IEEE STD 1159-2009).

Notch Filter: A band-reject cavity filter designed with a high Q resonant circuit to attenuate a narrow band of frequencies while allowing all other frequencies to pass through with only a slight loss of signal strength.

NRC: Nuclear Regulatory Commission

Objectionable Current: Any current flow over conductors not designed to normally carry current. For example, an equipment grounding conductor is not intended to carry current, except during a fault condition.

Operating Temperature: Temperature within an equipment case, with the equipment operating at a given capacity or load.

ORV permit: Off-road vehicle permit. A permit that grants the holder the right to drive a motorized vehicle through areas inaccessible by road.

OSHA: Occupational Safety and Health Administration: United States federal government regulatory agency responsible for standards regarding personnel safety at commercial and industrial sites.

Paging: A one-way communication system in which the receiving unit is sent a digital message. Paging can be provided as a PCS service.

Panelboard: A single panel or group of panel units designed for assembly in the form of a single panel, including buses and automatic overcurrent devices and equipped with or without switches for the control of light, heat or power circuits; designed to be placed in a cabinet or cutout box placed in or against a wall, partition or other support; and accessible only from the front.

PANI: A method of bonding conductors to the MGB/PBB in a specific order, depending on their origin.

Passive Intermodulation (PIM): Intermodulation that occurs in passive devices (for example, cables, connectors, antennas, lightning protectors, and so on) that are subjected to two or more high power signals. When two or more RF signals encounter a nonlinearity, they create new signals; these new signals may cause interference. Sources of nonlinearity may include loose metal-to-metal contacts (for example, poorly terminated RF connectors), metal flakes or shavings inside RF connectors, rusty or corroded surfaces, contaminated surfaces (for example, dirt, dust, moisture or oxidation), nonlinear metals (for example, nickel, steel, ferrite). PIM may also be created at nearby metallic objects in the path of the transmit antenna (for example, rusty bolts, roof flashing, vent pipes, guy wires, and so on).

PBB: Primary Bonding Bar.

PCS: Personal Communication Services.

Personal Communication Services: A digital communications system that provides data services such as messaging and paging as well as digitized voice.

PERT chart: Program, Evaluation and Review Technique chart. A flowchart showing the relationship and sequence of events comprising a project.

PIM: Passive Intermodulation.

Plat book: A document that depicts the legal ownership of specific parcels of land, usually in relation to a county, township, section or range.

Plenum: A compartment or chamber to which one or more air ducts are connected and that forms part of the air distribution system.

Practicable: Capable of being done, effected, or put into practice, with the available means; feasible.

Point of entrance: The point of emergence through an exterior wall, a concrete floor slab or from a rigid metal conduit or an intermediate metal conduit effectively bonded to a grounding electrode system.

Primary Bonding Bar (PBB): The single grounding point inside an equipment enclosure to which all other interior ground wires are ultimately bonded. There is one primary bonding bar per building or equipment area at a communications site. Also known as Master Ground Bus Bar (MGB).

Pulse method: A method for tower guy wire tensioning.

PSTN: Public Switched Telephone Network.

QA/QC: Quality Assurance/Quality Control.

R56: The Motorola Solutions committee responsible for enacting standards related to communication site construction and installation practices. R56 also refers to the literature distribution number formerly used for this manual, Standards and Guidelines for Communications Sites (PN 68P81089E50).

Rack: A standard equipment rack used for supporting communications equipment installed in an existing Building or Shelter.

Rack Bonding Bar (RBB): A single bus bar to which all equipment ground wires are bonded within a single equipment rack. Also known as Rack Ground Bus Bar.

Rack Ground Bus Bar: A single bus bar to which all equipment ground wires are bonded within a single equipment rack.

RBB: Rack Bonding Bar.

Return Loss (RL): Similar to VSWR, but measured in dB. Return Loss is the loss of power in the signal returned (reflected) by an impedance mismatch in the transmission line (coax). The mathematical range is from 0dB (open or short) to infinity (perfect match).

RF: Radio Frequency.

RFDS: RF Distribution System.

RFP: Request For Proposal.

RF Distribution System: A system that combines RF signals so that multiple transmitters and receivers tuned to different frequencies can use a single antenna.

RGB: Rack Ground Bus Bar.

RH: Relative Humidity.

RMS: Root-Mean-Square.

R-Value: A standardized rating system of thermal insulation effectiveness. Higher values denote greater insulating effectiveness.

SAD: Silicon Avalanche Diode.

Safety climb: Equipment that is attached to a tower to safely enable tower climbing.

Sag: A root mean square (RMS) reduction in the AC voltage, at the power frequency, for durations from a half cycle to a few seconds (IEEE STD 1100-2005) (see also Swell). A multi-cycle, under-voltage condition that can be caused by ground faults, undersized power systems, lightning or a sudden start-up of a large electrical load. The IEC terminology for sag is “dip.”

SBB: Secondary Bonding Bar.

SBCCI: Southern Building Code Congress International, Inc.

Secondary Bonding Bar (SBB): A Secondary Bonding Bar (SBB), previously referred to as a Sub System Ground Bus Bar (SSGB), is a bus bar used as a convenient extension of the Primary Bonding Bar (PBB) or Master Ground Bus Bar (MGB).

Seismic rating: Any of several standardized systems of rating an area's probability and intensity of seismic activity based on geological and empirical data. This publication references the Moment Magnitude (MM) rating standard recognized by the Uniform Building Code. Ratings of “0” (least probability with the least intensity) through “4” (greatest probability with the greatest intensity) are accordingly assigned to various regions.

Separately Derived System: A premises wiring system in which power is derived from a transformer or converter winding. It has no direct electrical connection, including a solidly connected grounded circuit conductor, to the supply conductors originating in another system.

Service Entrance: The point at which the utility enters a facility and the utility ground rod is attached.

Shelter: A Permanent structure built on a foundation that contains communications equipment and related ancillary support systems and may contain other unrelated equipment and/or facilities. A Shelter **shall** be suitable for temporary human occupancy during equipment installation, maintenance and use.

Silicon Avalanche Diode: A two-terminal voltage protection device in which resistance across the device markedly decreases when the voltage across the device reaches a specified threshold.

Simulcast: A system configuration using simultaneous transmissions of information on the same frequencies. This configuration extends communications over a large coverage area. Each repeater on the same frequency has identical transmit parameters to ensure the intended transmission format.

SPD: Surge Protective Device

Swell: An increase in RMS voltage or current at the power frequency for durations from 0.5 cycles to 1.0 minute (IEEE STD 1100-2005 and IEEE STD 1159-2009).

TETRA: Terrestrial Trunked Radio

Total Harmonic Distortion (THD): The ratio of the root square value of the harmonic content to the root square value of the fundamental quantity, expressed as a percentage of the fundamental (IEEE STD 1100-2005).

Transient: A sub-cycle disturbance in the waveform that is evidenced by a sharp, brief discontinuity of the waveform. May be either polarity and may be additive to, or subtractive from, the nominal waveform (IEEE STD 1100-2005). See IEEE STD 1159-2009, *Recommended Practice for Monitoring Electric Power Quality*, section 4.4.1, for details on transient definitions, types and causes.

TVSS: Transient Voltage Surge Suppressor

VSWR: Voltage Standing Wave Ratio

Site Design and Development

This chapter provides requirements and guidelines for site design and development. Site development refers to the civil, structural, mechanical, and electrical engineering and installation of supporting equipment at a communications site. The chapter primarily discusses new site construction. Adding onto an existing site or installing a site in an existing facility requires that the scope of work, design and drawings be specific to these locations. It is recommended to consult with Motorola Solutions' Site Design and Integration Team for new construction, co-location, and renovation work.

This chapter contains information on the following topics:

- “Compliance with RF Energy Exposure Standards” on page 2-1
- “General Outline of Work” on page 2-2
- “Planning” on page 2-2
- “Constructability Review” on page 2-6
- “Electrical Service” on page 2-8
- “Foundation Design and Installation” on page 2-9
- “Concrete and Soils Installation Monitoring” on page 2-12
- “Site and Facility Acceptance Testing” on page 2-13
- “Tower Design and Construction” on page 2-14

The design and development of communications sites is critical not only to optimal functioning of the communications system, but also to the safety of installation and maintenance personnel involved with building and maintaining the system. The importance of implementing and following safety programs, during construction as well as during the system's useful life, cannot be overemphasized.

All final construction drawings and specifications for a new site should be provided by a properly licensed engineering firm. This ensures the design is adequate for the site conditions and helps ensure accurate records of site construction are available.

2.1 Compliance with RF Energy Exposure Standards

In planning, installing or modifying any antenna tower or other antenna site, the need to comply with regulations and standards concerning human exposure to RF energy must be considered. Factors to be considered include:

- The location, direction, transmission power, frequency, physical characteristics and design of all antennas and other equipment at the site, in light of the existing or possible human occupation or usage of the adjacent areas.
- Any necessary and appropriate steps to limit or control human access to adjacent areas, including limited-access doors, fencing, signs and training.
- Appropriate operational procedures to ensure ongoing compliance with RF energy exposure regulations and standards when the antenna site is operational.

There should be a clear determination of who will be responsible for each aspect of compliance assurance, with the understanding that the operator or site owner bears ultimate responsibility for compliance. Additional information is provided in Appendix A, “Electromagnetic Energy (EME) Information”.



IMPORTANT

All work shall conform to applicable codes and regulations imposed by authorities having jurisdiction.

All contractors performing work at a site and all equipment vendors must be competent and qualified. A list of qualified contractors resides with Motorola Solutions' Site Design and Integration Team and with Motorola Solutions' Environmental Health and Safety (EHS) director.

2.2 The Motorola Solutions Site Design and Integration Team

The Motorola Solutions National Site Design and Integration Team (NSDIT) was developed to provide consistent and cost effective design and construction solutions utilizing key personnel with vast experience, expertise and knowledge in the public safety and construction arenas. The NSDIT key areas of expertise include, but are not limited to, site acquisition and leasing, zoning, architectural engineering, environmental services, construction management, site preparation, site construction (including tower foundation and tower erection), co-location (including water tower and roof-top applications), outdoor cabinets and tenant build-outs. The NSDIT will be involved on a nationwide basis for all projects that involve any of the activities stated in this section. NSDIT contacts will be available on the internal and external R56 websites.

2.3 General Outline of Work

The following is a high-level overview of major site development tasks and the order in which they are typically performed.

- Planning and site design drawing preparation
- Site surveying/staking
- Constructability review
- Installing temporary facilities if necessary
- Clearing land of vegetation
- Installing erosion control barriers
- Excavating and building access road
- Installing utility/electrical metering base
- Excavating and establishing subgrade and drainage requirements
- Excavating and installing shelter and any ancillary foundations
- Excavating and installing tower foundations
- Installing equipment shelter and ancillary equipment, including backup power systems
- Installing electrical conductors and other utility installations
- Energizing equipment shelter
- Installing tower, antennas and RF transmission lines
- Installing tower lighting system
- Installing fencing and gates
- Backfilling, grading and bringing site up to final grade
- Startup and testing of facility equipment
- Performing final cleanup and obtaining customer approval signatures

2.4 Planning

Planning the development of a communications site is crucial because the activities involved in constructing a site must be effectively organized in order to complete the project efficiently.

2.4.1 Location of Utility Entrances

All utility entrances (for example, AC power, phone company, RF cables, water supply, gas supply, and so on) to the facility should be located in the same general area of the shelter and should be located as close together as is practicable (IEEE 1100-2005).



IMPORTANT

In order to achieve true single-point grounding, all utilities and communications cable must enter the facility in the same general area. See Chapter 4, “External Grounding (Earthing) and Bonding”, and Chapter 5, “Internal Bonding and Grounding (Earthing)”, for more information.

2.4.2 Location of AC Power Neutral-Ground Bond

Equipment performance and the susceptibility of a communications site to damage from lightning are affected by the location of the AC power neutral-ground bond. See “Location of Neutral-Ground Bond” on page 6-5.

2.4.3 Site Development Drawings

To help ensure site development plans are developed in accordance with jurisdictional codes and specifications, it is critical that an engineering firm be consulted.

Typical site development drawings should include (but not be limited to) the following:

- General compound and site layout relative to the surroundings
- Location of access road if applicable
- Location of existing utilities
- Road profiles (cut and fill requirements)
- Existing road profile
- New road profile depicting road grade. Attempt to achieve a grade of less than 10%. Cranes, concrete trucks and other heavy construction or delivery shipments must have access to the site.
- True North/South and East/West Construction baselines as represented from the tower center (or center of site structure).
- Guy anchor location data schedule (if applicable). Typically the bottom of an anchor head should be 305 mm (12 in.) to 457 mm (18 in.) above final grade.
- Foundation Plan, including general layout of all required foundations and foundation schedule depicting applicable foundation elevations
- Grading Plan showing general grade elevation and slope of compound and access areas
- Sediment Control Plan showing location of hay bales or silt fences to prevent soil erosion
- Grounding electrode system design showing all typical exterior grounding requirements (see Chapter 4, “External Grounding (Earthing) and Bonding”). Soil resistivity measurements may also be depicted (see Appendix B, “Soil Resistivity Measurements”).
- Typical access road cross section and culvert detail, showing the following:
 - Cross section of access road
 - Drainage requirements
 - Curb cut requirements
- Equipment shelter foundation and details, showing the following:
 - Foundation layout (depth, length and width of all foundations)
 - Cross-sectional view of foundations for rebar placement

- Utility plan and installation details, showing the following:
 - Layout and installation routes for required utilities
 - Types of instrumentation required if applicable
 - Electrical one-line and service installation details, showing electrical service installation
- Telephone installation details, showing type of telephone line installation if required
- Fence enclosure and guy anchor fence plan showing fencing installation

2.4.4 Land Survey and Site Development Staking Considerations

Prior to finalizing site development plans, the site surveying firm should supply the following items at a minimum:



NOTE

Topographic and property boundary surveys **shall** be signed and sealed by a Registered Professional Engineer (or as required by jurisdictional law).

- Electronic (in compatible software version) and paper copies of property boundary surveys, clearly showing all easements, rights-of-way and boundaries. The property survey should be overlaid on the topographic survey to show property boundaries with respect to surface conditions.
- Electronic (in compatible software version) and paper copies of topographic surveys showing all relevant surface conditions and characteristics, ensuring proper contour lines to convey relative surface height or depth.
- East/West and North/South construction baseline delineation.
- Latitude, longitude and elevation of proposed center of tower in relation to the communication compound.

Site development staking should be performed upon completion of site development plans and required approval. It is recommended that site development staking be performed by the original surveying firm. The contractor performing the fieldwork and the surveyors should have a kickoff meeting to set expectations, understand and agree to a process that ensures timely execution.

Electronic and paper copies of the completed construction drawings **shall** be transmitted back to the surveyor to minimize the chance for errors in determining property boundary encroachment or engineering errors. At a minimum, site development staking should include (but not be limited to):

- Easement/right of way locations
- Temporary easement locations
- Temporary and permanent roadways
- Roadway curb cut and radius locations
- Center of tower
- Site fence corners
- Center of tower leg locations
- Building foundation corners
- Center of inner and outer guy anchor locations

2.4.5 Temporary Facilities

The following items are typically required during construction. Plan for these items before construction begins so they will be available when needed.

- Staging, fabrication, and construction areas
- Drives, walks, and bridges

- Public access
- Telephone
- Sanitary and cleanup facilities
- Drinking water
- Light and power
- Heat
- Enclosures and storage
- Dumpsters and trash removal services (do not burn trash onsite.)
- Restrictions on access to equipment shelter (do not use shelter as a workshop)
- Personnel and tool trailers

2.4.6 Geotechnical Considerations

Geotechnical investigations are required for all projects that involve subsurface foundation installations, engineering design parameters and other related aspects of site development. Geotechnical data obtained in these investigations **shall** be provided to the tower and foundation designers and site engineering firm in a compatible electronic format.

Unless otherwise specified, tower foundation and anchor design **shall** be executed in accordance with the latest revision of ANSI/TIA-222 (or other applicable local Standards body design requirements). It is highly recommended that the customer, tower and foundation designer, site-engineering firm, and the appropriate Motorola Solutions representative hold a meeting to set expectations, requirements, parameters, and approval process to ensure timely completion of the designs.



NOTE

Some contracts and geographical locations may require additional geotechnical information. Consult a reputable geotechnical firm and the tower and foundation designer to ensure all required geotechnical information is included in the report.

- Pocket penetrometer tests should not be substituted for unconfined compression tests.
- For each layer of soil encountered, the following items should be determined by field or laboratory testing and summarized in the soils report depending on the types of foundations recommended:
 - Standard penetration values
 - Soil classification and elevations
 - Angle of internal friction
 - Unconfined compression strength and cohesion
 - Tension and compression skin shear (for piles, caissons or drilled piers)
 - In-situ soil density and moisture content
 - Expected ground water fluctuations
 - When drilled piers are feasible, the plasticity index and over-consolidation ratio **shall** be determined.
 - The recommended type(s) of foundations to be considered, as well as corresponding design parameters for uplift, compression and lateral load
 - Construction techniques to ensure the design parameters are obtained.

2.5 Constructability Review

The constructability review leverages construction knowledge and experience in planning, design, procurement and field operations to achieve overall project objectives. All project parties should become involved in a constructability program at the onset of a project to ensure there is a maximum influence on overall cost, quality, cycle time and functionality. The following are some of the basic steps for a constructability review.

- Establish criteria for selection of members
- Establish constructability objectives/concepts
- Establish project objectives (scope) relative to constructability objectives
- Compare contractual scope objectives and constructability objectives with requirements of this manual
- Establish roles and responsibilities
- Establish the importance of teamwork
- Determine level of formality for constructability program
- Define specific constructability procedures
- Integrate constructability into project activities
- Identify appropriate measures for objectives

2.6 Site Walks

As defined in this document, site walks refer to post contract award. Site walks familiarize involved parties with the development plan for a proposed site. After a site's use has been confirmed, a site walk **shall** be conducted to examine as much detail about the site as practicable and to clearly determine and describe responsibility for all aspects of the site development. It is recommended where practicable that all involved parties participate in a site walk. This includes, but is not limited to, geotechnical, site engineering, the site design team or site design team designee, contractor and the customer personnel. This saves time, encourages multiple opinions and ensures that all parties agree on preliminary layouts.

At a minimum, the following items should be completed during the site walk:

- Choose the specific location of the facility. If survey information is not available or applicable, precise location information is required for future reference and equipment deliveries.
- Note general condition of site and surrounding area, including pre-existing flooding or erosion conditions. Note site characteristics and any notable items from the surrounding properties.
- Discuss site layout. General agreement and concurrence should be reached on preliminary site layout and development with respect to the site and its characteristics.
- Verify the location of the nearest commercial utility/electrical service. If available, note the name of the service provider along with a service pole number or approximate location of nearest service pole.
- Observe accessibility. Access to the site is of the utmost importance and should be thoroughly investigated and noted at this time. Any obvious easement or security issues should be noted and investigated also.
- Observe and investigate weight (load) considerations. Load restrictions, whether on the access road, elevator or floor, should be thoroughly investigated and noted at this time. Obtaining special permits if required to access a site may be time-consuming.



NOTE

Without proper investigation and planning, load restrictions can prevent a site from being used.

- Note potential environmental concerns such as wetlands, dump site, oil spills, garbage piles, nearby truck stops and fueling stations.
- Note the type of property (existing facility, building top, private, state or federal property).

- The construction location should be relatively clear of trees and brush. There should be an adequately sized layout/fabrication area adjacent to the construction area; lack of such area may hinder cost-effective construction.
- The construction location should be on level, firm land free of drainage and soil erosion problems.
- In locations where permafrost exists, the building must be isolated from the surrounding earth. Even the small temperature differential presented by an equipment shelter may be sufficient to melt the surface soil, leading to major structural and foundation damage. Workable solutions include building the structure on stilts or insulated pilings. Though it is also possible to construct on bedrock, special methods for anchoring and grounding must be used.
- If an existing tower or structure is to be used to support proposed additional antennas and transmission lines, then a structural and foundation analysis **shall** be performed.



NOTE

It may be impractical or impossible to add more antennas to an existing tower or structure due to the retrofitting required or the physical limitations of the tower, structure or foundations themselves.

- If an existing tower or structure is to be used to support proposed antennas and transmission lines, the site should be observed for potential electromagnetic energy (EME) issues. An interference analysis should be performed to determine interference that may exist at the location.

Additionally, these tasks may be recommended to be performed based on the initial site walk:

- On existing facilities, perform a preliminary R56 compliance inspection to ensure proper planning and advisement to the customer (if required).
 - Ensure proper testing and measurement of existing ground system integrity, if practicable. R56 inspection should be performed by R56 certified personnel.
- Perform four-point soil resistivity testing if required. See “Soil Resistivity Measurements” on page B-1.
- Take subsurface soil core samples for soil resistivity if practicable.

2.7 Permitting, Zoning, Code and Regulatory Considerations

Obtaining permits and complying with local codes, ordinances and regulations can be complicated and time-consuming. It is highly recommended that all involved parties carefully plan and execute this portion of the project. To avoid unexpected problems, confer with all authorities having jurisdiction (AHJ) before beginning construction and provide them with clear execution plans. To assist with permitting, zoning, code and regulatory considerations, it is recommended that the Motorola Solutions Site Design and Integration Team be consulted.



IMPORTANT

Some municipalities require all communications installations that share public safety facilities (police or fire stations, hospitals, and so on) to be constructed to standards under the State “Essential Services Act.” This requires that seismic upgrading and installation practices be met and that emergency power systems be upgraded to handle the new demand for the entire facility, sometimes at considerable additional costs. Even if the shared communications site lease does not specifically identify the need to comply with Essential Services Act standards, there may be “catch all” clauses stating that “all applicable local, state and federal laws and requirements shall be met.” It is important to research this potential issue while qualifying a particular site.

2.7.1 Americans With Disabilities Act Considerations



NOTE

The following specifically applies to sites located within US jurisdiction. However, other jurisdictions may have similar or more stringent requirements. In all cases, the more stringent requirement takes precedence.

The Americans With Disabilities Act (ADA) is a US federal program signed into law as Public Law 101-336 July 26, 1990 104 Statute 327. Of greatest importance regarding a communications site is the following language contained in Title I, which requires: “business must provide reasonable accommodations to protect the rights of individuals with disabilities in all aspects of employment.”

At communications sites, this may result in changes in workstations and work areas to provide required accommodations. Some effects on a communication site regarding ADA compliance are:

- Providing extra-wide entry doors
- Providing a ramp for building access, a hand rail and a turnaround area for wheelchairs within the building
- Providing convenient placement of telephones and light switches
- Providing dedicated paved handicap parking spaces

While some domestic municipalities are not yet requiring ADA compliance, many large cities are. Such regulations may significantly affect communications site development. The Uniform Building Code (UBC), Chapter 31 Accessibility, addresses these requirements in detail. UBC Chapter 31 Article 3104(3), Egress, in part, specifies a requirement for a 1.22 m (48 in.) width doorway. Article 3104(4), Article 3105 Facility Accessibility, requires a telephone or other communications system **shall** be available.

2.7.2 Federal Clean Water Act Considerations

The Federal Clean Water Act (FCWA) **shall** be considered during site development. FCWA programs administered by local governments sometimes vary with different requirements and enforcement for specific locations. The FCWA may require common HVAC system condensate water be carried to a legal building drain system and may not be disposed of in the ground soil. This may result in requirements to include condensate pumps on HVAC systems and to plumb the HVAC condensate water to a proper sewer system.

2.8 Fire Suppression

Fire is a hazard that must be taken into account when designing a communications room or structure. An appropriate means of preventing and controlling the spread of fire must be provided to help protect people sharing the structure or working with the equipment. Appropriate fire detection and suppression is typically required at communication sites where persons are manning the facilities. Where applicable, these facilities **shall** be designed in accordance with local jurisdictional codes.



IMPORTANT

Consult the Authority Having Jurisdiction (AHJ) regarding fire suppression requirements.

2.9 Electrical Service

The following list is provided to help organize, manage and coordinate electrical service installation. Some items may not apply to all projects. Ensure the electrical installation process is tracked, managed and documented by responsible parties.

- It is recommended that one person from the utility company be established as the point of contact. Ensure the utility company's work order tracking methods and processes are understood. Typically a customer tracking number is assigned.
- Where practicable, keep overhead lines and poles at least 61 m (200 ft) from the site compound area during construction. This helps protect against accidental contact by construction or maintenance equipment and hazards associated with ice falling from the tower while under construction.
- To facilitate single-point grounding, request the electrical service enter the site building on the same wall as, and near to, the entry point for the antenna transmission lines.
- Proper separation between overhead electrical service conductors and antenna transmission lines **shall** be a minimum of 0.6 m (2 ft) (NFPA 70-2017, Article 810.13). This may require coordination between the site development engineer and the shelter manufacturer to ensure consistency in layouts.

- Utility installations are jurisdictional. Ensure that it is clearly understood who the utility supplier will be. This is best achieved with a site meeting.
- Coordinate other utility installations such as closed-circuit television (CCTV) and telephone service provider.
- Supply the utility with an electrical utility information form.

**NOTE**

Additional site-specific load or use information, such as type of equipment, generator or uninterruptible power supply (UPS) information, may be required.

- Obtain an installation cost estimate from the utility company.
- The proper easement paperwork **shall** be obtained and provided to the utility.

**NOTE**

Governmental agencies transferring land or granting easements may take considerably more time than private landowners.

- A copy of the utility site installation sketch, staking sheet or overlay **shall** be obtained. It is imperative to check that the utility company interpreted the request for service correctly and that they have conformed to easement restrictions. It is easier to correct problems in the design phase than after service installation has started.
- Typically, final electrical service connection to the meter pedestal will not take place until the utility has been paid.
- The utility company usually requires a site address before they will connect power. Utility companies may or may not assign the address. It is more likely the local township will assign the address.
- A jurisdictional electrical inspection is usually required before the utility company connects power.
- The electric meter, but not the meter pedestal, is typically supplied by the utility. Verify who is responsible for providing the electric meter.
- Electrical service installations in very cold climates are typically much more expensive and likely to slow the installation schedule.

2.10 Foundation Design and Installation

**NOTE**

When a soil boring test is performed, the local soil resistivity, soil pH and the type and concentration of dissolved salts should be established to aid in the design of the grounding electrode system (TIA-222). See “Dissimilar Metals and Corrosion Control” on page 4-52.

2.10.1 Foundation and Geotechnical Services

Foundation monitoring services are required when structural soils and foundation work is performed. They may also be required for certain other sub-surface and surface work. Monitoring services report whether the soils and concrete conform to design limits specified by either the tower and foundation designer or site engineering firm before, during or after installation. If the specified design limits are not met, the foundation monitoring service **shall** notify the contractor and Motorola Solutions to ensure that the noncompliance is corrected. This service is sometimes performed by the geotechnical firm.

**CAUTION**

To prevent accidental damage to underground utilities, always have the local utility company or utility locator service locate the underground utilities before excavating or digging at a site.

**NOTE**

Firms offering this service may be able to provide a checklist to use as a guideline for the project.

2.10.2 Concrete Foundation Design and Installation Considerations

This paragraph describes the design and construction considerations and requirements for communications site concrete foundations, including prefabricated communications shelter foundations and tower foundations.

**NOTE**

If concrete encased electrodes (Ufer grounds) are to be utilized, they must be addressed, engineered and installed before the concrete is poured. See “Concrete-Encased Electrodes” on page 4-23.

2.10.2.1 Planning

- Foundation design for prefabricated shelters and other equipment **shall** be based upon site soil conditions as noted in the geotechnical report. These foundation plans for buildings and ancillary equipment **shall** be designed by a licensed Professional Engineer and the design **shall** be included in the construction drawing package.
- A Professional Engineer or contracting firm **shall** determine whether the soil is adequate to properly support the concrete foundation or slab. The Professional Engineer or contracting firm **shall** determine the excavation depth and the required fill, if required.
- To ensure personnel safety, all excavations **shall** be conducted in accordance with Occupational Safety and Health Administration (OSHA) safety and excavation regulations, or other applicable Occupational Safety and Health standards and/or local safety regulations (whichever is most stringent).
- All foundations **shall** be designed by a certified professional engineer.
- A concrete foundation is typically used for building and shelter installations. If a foundation is used, the foundation **shall** be appropriate for the structure.
- All foundation construction **shall** be performed by a qualified contractor specializing in this work.
- If a site is to use concrete-encased grounding electrodes within the foundation or other concrete structures, appropriate measures **shall** be taken to accommodate the grounding system within a concrete structure before the concrete is poured. See Chapter 4, “External Grounding (Earthing) and Bonding,” for additional information.
- A foundation for a prefabricated shelter **shall** be built in accordance with the manufacturer's specifications and site specific soil conditions. The Architectural and Engineering firm providing the construction drawings will coordinate and include final foundation designs in the drawings.
- Foundation design **shall** consider any precipitation conditions unique to the location. These considerations include (but are not limited to) elevated (pier type) platforms used in low-lying areas prone to regular flooding and elevated foundations used to prevent burial of site due to snowfall. Special foundation designs include:
 - Footings
 - Piers
 - Columns
 - Grade beams

2.10.2.2 Preparation

- All excavations on which concrete is to be placed **shall** be substantially horizontal on undisturbed and unfrozen soil and **shall** be free of loose material and excess ground water. Methods for removing excess ground water **shall** be provided if required.
- The foundation area **shall** be graded to provide water runoff and prevent water from standing. The final grade **shall** slope away in all directions from the foundation.

2.10.2.3 Pouring

- Concrete forms **shall** be used as required for the proper execution of the plain and reinforced concrete work. Sufficient quantities **shall** be used to properly execute and expedite work without endangering the safety or strength of any part of the construction.
- All forming **shall** be true and rigid, thoroughly braced and sufficiently strong to safely carry all dead and live loads to which it may be subjected. The elimination of forming by a monolithic pour against undisturbed soil **shall** be allowed **only** if approved by a soils engineer and/or a qualified Motorola Solutions representative.
- All steel reinforcement **shall** be furnished and installed in accordance with the approved foundation drawing. Unless otherwise specified or shown on plans, reinforcement **shall** consist of preformed bars of intermediate grade, manufactured from new billet stock. Metal reinforcement **shall** conform to the requirements of the latest version of *Specifications for Deformed and Plain Carbon-Steel Bars for Concrete Reinforcement*, ASTM A615 / A615M, or applicable jurisdictional code, whichever is more stringent.
- Anchors, bolts and miscellaneous iron work **shall** be set as shown in the drawings before pouring concrete. Embedded items **shall** be held rigidly in place during placing and curing of concrete. Placing rebar in position as the concrete is placed **shall not** be permitted.
- Concrete **shall** be vibrated and thoroughly consolidated around all embedded items.
- At least one week prior to all concrete pours, the proposed concrete mix design **shall** be submitted to Motorola Solutions or its contractor for verification of design specifications.
- When concrete is placed, certificates **shall** be furnished for each delivery vehicle or every 5.4 m³ (7 cu. Yds), showing the mix proportions, additives, compressive strength, and the brand name and type of cement.
- Concrete **shall** be so deposited that there will be no separation or segregation of aggregate. Maximum free drop **shall not** exceed 2.43 m (8 ft).
- Concrete **shall not** be placed when the outdoor temperature is below 4.5° C (40 degrees F) nor when the concrete is likely to be subjected to freezing temperatures before final set, except when adequate provisions have been made for protection. When deposited in the forms, the concrete **shall** have a temperature of not less than 15.5° C (60° F) and not more than 32° C (90° F). A suitable means **shall** be provided to maintain the temperature above 10° C (50° F) for 7 days. The materials **shall** be heated before mixing to prevent concrete from freezing.

2.10.2.4 Backfilling

- After completion of the foundation and other construction below grade, and before backfilling, all excavations **shall** be clean of vegetation, trash, debris and inorganic materials.
- A soils engineer **shall** determine if the onsite excavated materials are adequate or suitable for use as backfill material. If the material is not suitable, then engineered soils **shall** be determined by the soils engineer.
- Foundation backfill **shall** be placed in layers no more than 305 mm (12 in.) deep before compaction. The backfill requirements of each site differ based on conditions at the site.
- A foundation for an outdoor communications cabinet **shall** be level and sealed.

2.10.3 Concrete and Soils Installation Monitoring

Table 2-1 FOUNDATION AND SOILS MONITORING REQUIREMENTS

Requirement	Type of Foundation			
	Drilled Piers (Caissons)	Deep Mat	Guy Tower Sites	Eqpt. Shelter Foundations
Confirm and obtain concrete mix design from foundation designer.	X	X	X	X
Perform penetrometer test at the base of the mat or tower excavation to verify soil bearing conditions. The number of test locations is dependent on soil conditions. The Geotechnical firm shall provide bearing values for specific locations. NOTE: Penetrometer tests are not required at the bottom of guy anchor thrust block excavations.		X minimum three (3) to five (5) locations	X minimum two (2) to three (3) locations	X minimum two (2) to four (4) locations
Collect bulk sample for Modified Proctor compaction testing. Expedite sample to lab to accommodate a seven-day concrete cure period (unless a high early type mix is used, then a shorter turnaround is required).		X	X	X
Identify specific caisson(s) being installed and include in daily field log and concrete report.	X			
Confirm and note caisson diameter and depth in concrete report.	X			
Confirm, note and ensure caisson bottom is clean and free of debris.	X			
For caissons, confirm and note placement of reinforcement cage and ensure it is centered in caisson pier. For other foundations, confirm and note placement of reinforcement steel with respect to foundation design.	X	X	X	X
Confirm and note that method of concrete placement is as specified by foundation designer(s).	X	X	X	X
Perform concrete field tests (slump, temperature and air content) and cast a minimum of one set of test cylinders (four cylinders per set) for every 19.1 m ³ (25 cu. yd.) of concrete placed. Perform new set of tests and cylinders once five yards beyond the 19.1 m ³ (25 cu. yd.) increment. Examples: • 61 m ³ (80 cu. yd.) = four sets of test cylinders • 23 m ³ (30 cu. yd.) = two sets of cylinders)	X	X	X	X
Confirm and note that a working vibratory wand is used to consolidate the upper 3 m (10 ft) of concrete placed in each caisson or the tower mat foundation.	X	X	X	X

Table 2-1 FOUNDATION AND SOILS MONITORING REQUIREMENTS (CONTINUED)

Requirement	Type of Foundation			
	Drilled Piers (Caissons)	Deep Mat	Guy Tower Sites	Eqpt. Shelter Foundations
Ensure that newly formed test cylinders are placed in an insulated cure box or other heated area to protect against freezing temperatures. Note that other methods of curing may be more acceptable or desired.	X	X	X	X
Test concrete cylinders in accordance with latest version of American Concrete Institute (or Authority Having Jurisdiction) standards and note in concrete test log.	X	X	X	X
Note unusual developments such as rejected concrete, weather or construction delays, difficulty in setting anchor bolts or casings stuck in place.	X	X	X	X
Perform, confirm and note density tests on each new lift of tower foundation backfill to verify it is compacted to 95% of the Modified Proctor maximum density value test (ASTM D1557). Note the type of compacting equipment used.	X	X	X	X
Specifically note the anchors or locations worked on and the order in which they were poured.			X	
Ensure backfill and undercut areas for non-structural applications (such as around pre-fabricated shelter foundations) are compacted to 90% of the maximum dry density value determined by the latest version of Standard Proctor test (ASTM D698).				X

2.11 Site and Facility Acceptance Testing

When site development (including tower construction, antenna and transmission line installation, utility connection, building or shelter placement or construction, and roadway construction) is complete, all applicable areas of the site **shall** be inspected and tested, to ensure all installations and alarms are functioning properly before the site is presented for customer acceptance. All aspects of the inspection and testing **shall** be documented. Items to inspect and test may include, but are not limited to, the following:

- Site AC power and alarms
- Transfer switch functionality and alarms
- HVAC equipment and alarms (including high and low temperature and high humidity)
- Generator functionality and alarms
- Fire or smoke detection devices
- UPS functionality and alarms
- Tower lighting functionality and alarms
- Dehydrator functionality and alarm
- Security measures such as door alarms and deadbolts

- Antenna and transmission line installations
- Concrete compressive strength requirements
- All aspects of the site, building and tower drawings are met or properly as-built
- General workmanship
- Site and building are clean and free of trash and debris
- Tower installation is in accordance with the latest version of ANSI/TIA-222 (or other applicable local Standards body design requirements)
- R56 audit (performed by a certified R56 auditor)

2.12 Tower Design and Construction

When designing a tower site with a related equipment shelter, it is recommended that the tower be placed a minimum of 9.1 m (30 ft) from the shelter where practicable. This distance provides a balance between line loss in the antenna transmission line and the reduction in the amount of electromagnetic energy (EME) induced into the shelter in the event of a tower lightning strike. The separation will also help increase the ability of the tower grounding electrode system to dissipate the lightning energy before it reaches the shelter. See IEEE 1692-2011 for more information.

Increasing the distance between the tower and shelter from 3 m to 9.1 m (10 ft to 30 ft) reduces the amount of EME induced into the building by a factor of 9 (EME reduction factor = distance factor²). For example, increasing the distance by a factor of 3 (from 10 ft to 30 ft) results in an EME reduction factor of 3², or 9.

All tower and tower loading design **shall** be performed by a registered professional structural engineer. If a structure other than a tower will be used to support a communication system antenna, the tower designer and/or a registered professional engineer specializing in tower structure design **shall** be contracted to analyze whether the structure can safely support the proposed load. Tower mapping may also be required. Twist and sway of a tower affects the performance of microwave links. Therefore it is imperative that the proper loading information for each tower **shall** be supplied to the tower designer to help ensure that the tower meets ANSI/TIA-222 (or other applicable local Standards body) requirements.

Tower height is dictated by a number of factors including, but not limited to, the following:

- Required RF coverage
- Location
- Seismic risk probability
- Available area
- Existing structures in the vicinity
- Terrain
- Required antenna height
- Federal Aviation Authority (FAA) or jurisdictional approval
- Future tower capacity

Unless otherwise specified, all towers and foundations **shall** be designed to the latest version of ANSI/TIA-222 unless jurisdictional laws or codes mandate otherwise. The following tower design requirements apply:

- A minimum of one safety climb **shall** be engineered, supplied and installed on every tower.
- EME precautions **shall** be as described in Appendix A, “Electromagnetic Energy (EME) Information”.
- Rest platforms **shall** be designed and installed per OSHA or other applicable standards, or as recommended by the tower manufacturer.

If additional antennas are to be added to an existing tower, or if a structure other than a tower will be used to support a communication system antenna, the original tower vendor (if available) and/or a registered professional structural engineer **shall** be contracted to analyze whether the tower or structure can safely support the additional load. Tower mapping may also be required.

Table 2-2 provides a brief comparison of the three most common tower types.

Table 2-2 COMPARISON OF TOWER TYPES

Factor	Self-Supporting	Guyed	Monopole
Cost	High More material required Foundation more expensive	Moderate More assembly cost required Land costs may be higher because more area is required for guy wires.	Moderate based on loading
Rigidity	High Self-supporting structure is typically more stable and better able to resist wind loading.	Moderate Provide resistance to wind sway, but are susceptible to torquing, especially when dish antennas are installed.	Low - wind resistance less than other types.
Land Required	Low	High - Location of guy anchors must be far from tower, requiring more property. May be unsuitable for populated areas due to land requirements	Low - Well-suited for urban areas with limited land availability.
Height	Moderate	High - Guyed towers may exceed 366 m (1200 ft)	Low
Growth Potential	Moderate	Moderate	Low - Monopoles capable of supporting growth with room to rent space to other users may cost significantly more to build.

2.12.1 Tower Design Drawings

The final tower foundation drawings **shall** show the following information at minimum:

- Reference to the soil/geotechnical report, including file number, date and firm performing report, used in calculations and design.
- Required concrete compressive strength to be achieved at 28 days
- Grade and/or type of reinforcing bar
- Concrete coverage requirements
- Whether welding of rebar is permitted
- Whether cold joints are permitted; if so, the joining procedure **shall** be specified.
- Whether permanent steel casings are permitted for caisson installations
- Whether temporary steel casings are or may be required due to the expected soil conditions
- Any recommended concrete installation techniques such as a tremie
- References to all codes (and sections of codes) applicable for the design

- Plan, elevation and section views depicting a minimum of the following:
 - Length, depth and width
 - Diameter
 - Finish grade with respect to top of foundation
 - Rebar size and placement
 - Anchor bolt size, type and placement
 - Above finish grade requirement for anchor heads (typically a minimum of 305 mm (12 in.))
- Estimated cubic yards of concrete per pier, caisson, mat, block or other type of foundation
- Backfill requirements such as but not limited to:
 - Material type
 - Thickness of lifts (typically lifts not more than 305 mm (12 in.) thick are acceptable).
 - Applicable compaction requirements; such 95% of modified proctor maximum dry density.
 - Applicable sub-grade compaction requirements; such as for a guy anchor. Upon completion of the excavation the designer may require certain compaction densities.
- Any other pertinent information that may be abstracted from the soils report, such as a high water table or large boulders.
- Any other pertinent construction or design information or considerations.

2.12.2 Design Considerations to Help Reduce Effects of Lightning

Site design and physical layout can affect the susceptibility of a communications site to damage from lightning. The following topics are given as options to help reduce the harmful effects of lightning at a communications site.

2.12.2.1 Point of Entry for RF Transmission Lines

Reducing the height at which the RF transmission lines (coaxial cables) leave the tower and enter the building can reduce the susceptibility of a communications site to damage from lightning (see Figure 2-1).

The reduction in height reduces the voltage on the RF transmission lines before they enter the facility. A suggested best practice is for the coaxial cables to enter the facility at a maximum height of 610 mm (2 ft) above the facility floor (see the United States National Weather Service Manual 30-4106-2004, “Lightning Protection, Grounding, Bonding, Shielding and Surge Protection Requirements”). See the PolyPhaser publication “Lightning Protection and Grounding Solutions for Communication Sites” for more information.



NOTE

The point of entry for RF transmission lines is especially important at facilities that are normally occupied, such as dispatch centers, and at facilities that are located on above-ground platforms (usually for the purpose of flood control). See Figure 3-5 for an example of a shelter located on an above-ground platform.

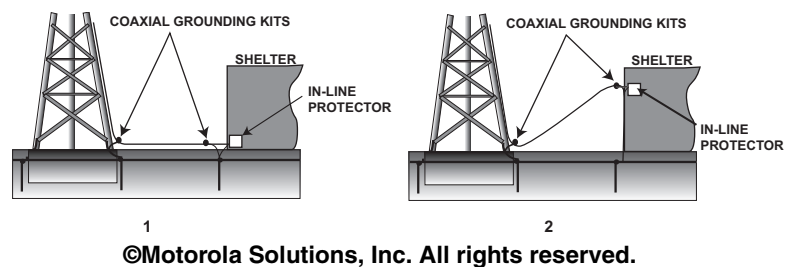

Figure 2-1 Transmission Line Entry Points (In Order of Preference)

2.12.2.2 Distance Between Tower and Building

Increasing the distance between the tower and building may reduce the susceptibility of a communications site to damage from lightning. Increasing the distance between the tower and building has the following benefits:

- It decreases the magnetic field associated with lightning that is coupled into the building. The amount of magnetic field coupled into the building decreases by the square of the distance. For example, the magnetic field coupled into a building would decrease by a factor of nine (9) if the distance between the tower and building is increased by a factor of three (3).
- It reduces the amount of energy that reaches the building via the RF transmission lines. This is because of the increase in inductance of the longer transmission lines.
- It reduces the amount of lightning energy that is propagated through the earth from the tower grounding (earthing) electrode system to the building grounding electrode system.
- Nine meters (30 feet) is considered a good compromise between protection level benefits and the length added to RF transmission line (IEEE 1692-2011, section 8).

2.12.2.3 Metallic Telecommunications/Data Lines

Wherever practicable, metallic telecommunications/data lines should be eliminated from the facility. Metallic telecommunications/data lines provide a conductive path into the facility for lightning energy. Elimination of metallic telecommunications/data lines through the use of fiber optic cable (or other isolation device) provides isolation from lightning-induced ground potential rise (GPR) and lightning energy. See IEEE 1692-2011 for more information.

2.12.2.4 Isolation of Building And Tower From Ice Bridge/Cable Bridge



NOTE

This section applies to tower and/or building-supported ice bridges and cable bridges.

In order to reduce the amount of lightning energy diverted toward the equipment building/shelter, and to provide seismic isolation between the building and tower, it is recommended that the cable bridge/ice bridge be secured to the tower using a non-conductive slip-joint type device if no support post is installed. Where a slip-joint type device is used, grounding of the cable bridge/ice bridge **shall** be completed as described in “Cable Bridge/Ice Bridge Grounding (Earthing) and Bonding” on page 4-108. See IEEE 1692-2011, section 9.2 for more information.

2.12.2.5 Use of Air Terminals on Towers

The use of air terminals (lightning rods) on a tower may be appropriate in some circumstances to protect antennas from a direct lightning strike. If the tower is over 45.7 m (150 ft) tall, side-mounted antennas are vulnerable to direct lightning strikes. Side-mounted antennas installed at a height greater than 45.7 m (150 ft) may be protected through the use of horizontal lightning rods. The horizontal lightning rods are attached to the tower, just above and below the antenna.

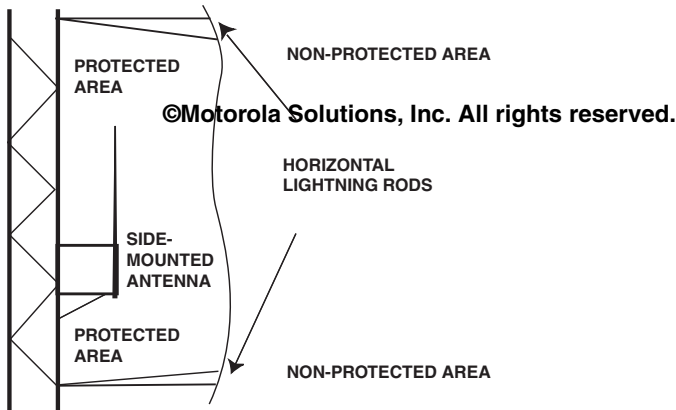

Figure 2-2 Using Horizontal Lightning Rods to Protect Side-Mounted Antenna

2.12.3 Tower Safety

Always observe the following safety guidelines when working with towers.

- Towers **shall** be erected and installed by bonded and licensed (where applicable) contractors specializing in such work.
- Any area involving tower construction **shall** be tied off to restrict entrance by unauthorized personnel.
- Fall protection measures **shall** be observed and implemented at any and all towers and structures, regardless of ownership, where climbing is required.
- Any and all applicable regulations regarding tower climbing **shall** be observed and implemented. The most stringent regulations **shall** supersede other regulations.
- Subcontractors **shall** be required to submit their written comprehensive Safety Program to Program Management and obtain approval prior to commencing any work.
- All tower climbing **shall** be in accordance with the Motorola Solutions Contractor Fall Protection Program.
- Towers **shall not** be overloaded.
- OSHA or other applicable standards regulations **shall** be observed in all phases of tower construction and maintenance.

2.12.4 Regulations Affecting Towers

The following regulations **shall** be observed:

- In the United States, the Federal Aviation Administration (FAA) regulates and approves towers, including but not limited to tower height, location, marking and lighting. Each state or jurisdiction may have additional regulating agencies which may designate specific marking or lighting requirements in addition to FAA requirements. It is highly recommended that the appropriate authorities having jurisdiction be identified and consulted before final tower design and construction begins.
- CFR 47, Part 17 – “Construction, Marking and Lighting of Antenna Structures” **shall** be followed to determine required paint markings and lighting for towers. Equivalent local standards **shall** be followed for nondomestic installations.

- A preconstruction notice **shall** be submitted to the FAA or local Authority Having Jurisdiction at least 30 days before the date of proposed construction or alteration is scheduled to begin, on or before the date a construction permit application is filed with the Federal Communications Commission (FCC). Ensure the FAA acknowledges receipt of the notice before beginning tower construction. Other notices may be required by the FAA on a case by case basis.
- All FAA, FCC and jurisdictional rules and regulations **shall** be strictly followed throughout tower design and construction and following tower completion. It is highly recommended that the appropriate authorities having jurisdiction be consulted before starting tower design and construction.
- Unless otherwise specified, tower foundation and anchor design **shall** be in accordance with the latest revision of ANSI/TIA-222 (or applicable local Standards body design requirements) or local jurisdictional code, whichever is more stringent.

2.12.5 Securing the Tower

After construction, unauthorized entry to a tower **shall** be controlled as follows:

- Install a fence around the tower. The fence should be at least 1.8 m (6 ft) high with barbed wire at the top.
- The guy piers of guyed towers should also be fenced with a gate and lock to help prevent accidental or malicious damage to the guy wires. A damaged or weakened guy wire could cause the tower to fall.
- If the tower has climbing pegs, the pegs should be removed from the bottom 6.1 m (20 ft) of the tower to deter unauthorized climbing.
- If the tower has a climbing ladder or elevator, it should be appropriately secured.
- Appropriate signage notifying restricted access to the tower area and identification of tower **shall** be affixed to the fence in a conspicuous location.

2.12.6 Antenna and Dish Antenna Loading

Antenna loading requirements are one of the most critical aspects of tower design. Loading requirements include, but are not limited to, the following:

- RF antenna quantity, size, type, manufacturer, frequency and elevation
- If required, future RF antenna loading requirements
- Microwave dish antenna quantity, size, manufacturer, frequency, azimuth, elevation and radome
- If required, future microwave dish antenna loading requirements
- Transmission cable diameter and type
- Sidearm length and location
- Lighting requirements
- Additional ice or wind loading requirements applicable to the selected site
- Safety apparatus such as climbing ladders and rest platforms
- Miscellaneous optional equipment, such as ice shields



NOTE

All loading on a tower must conform to the latest revision of ANSI/TIA-222.

See Figure 2-3 for an example of a tower loading report.



Site Designator	7XXX	Tower Loading Information									
MSP No	7XXX	Tower Type: Self Support 21-Dec-									
City	NewTown	Phase	3	Tower Height: 475							
County	Charles	District	7	Tower Reference Azimuth: 0							
Microwave Antenna System Information				Ant. Engineering File Number:							

Path No	Path Destination	Path Density	Radio Capacity	Azimuth	Path Distance	Antenna Height (CL)	Dish Size	Space Diversity	Diversity Ant. Ht (CL)	Div Dish Size	ERIP (dBi)	Polarization
91	7203b	high	28	43	14.8	135	6	<input checked="" type="checkbox"/>	95	6	66.8	Vertical
88	7302p4	medium	12	121.4	10.6	142	6	<input checked="" type="checkbox"/>	102	6	66.8	Vertical
89	7001b	high	28	160.605	11	160	6.1	<input checked="" type="checkbox"/>	99	6	64.8	Vertical
90	7904p1	High	28	237.145	15.8	125	8	<input checked="" type="checkbox"/>	80	6	69.3	Vertical
101	7804c	high	28	333.9	11.4	106	6	<input checked="" type="checkbox"/>	71	6	66.8	Vertical



©Motorola Solutions, Inc. All rights reserved.

Site Designator	7XXX	Tower Loading Information									
MSP No	7XXX	Tower Type: Self Support 21-Dec-99									
City	NewTown	Phase	3	Tower Height: 475							
County	Charles	District	7	Tower Reference Azimuth: 0							
Microwave Antenna System Information				Ant. Engineering File Number:							

Path No	Path Destination	Path Density	Radio Capacity	Azimuth	Path Distance	Antenna Height (CL)	Dish Size	Space Diversity	Diversity Ant. Ht (CL)	Div Dish Size	ERIP (dBi)	Polarization
---------	------------------	--------------	----------------	---------	---------------	---------------------	-----------	-----------------	------------------------	---------------	------------	--------------

<p>800 MHz Antenna Information</p> <p>One 800 MHz Rx Ant. Ht: 445</p> <p>Number of 800 MHz Tx Ants: 2</p> <p>Mounted at a Height of: 475</p> <p>Model Number of Antennas: PD100175a</p> <p><small>NOTES:</small> All Line for the 800 MHz Antenna Systems will be 1 5/8" Heliax 1 5/8" Snap in hanger required for the site. 61</p>	<p>Relocated Existing Antenna Systems Loading Requirements</p> <p>Model Number of Antennas: DB212</p> <p>Mounted at a Height of: 200</p> <p>Quantity of Antennas: 3</p> <p><small>NOTE:</small> All Line for the non 800 MHz Antenna Systems will be 7/8" Heliax If tower is less than 250' mount relocated existing antennas at highest available location.</p>	<p>Tower Marking and Lighting Requirements</p> <p>Marked (Painted): <input type="checkbox"/></p> <p>Medium Intensity White: <input type="checkbox"/></p> <p>Dual Medium Intensity (White and Red): <input checked="" type="checkbox"/></p> <p>High Intensity White: <input type="checkbox"/></p> <p>Dual High Intensity (White and Red): <input type="checkbox"/></p> <p>Conventional Red Lighting: <input type="checkbox"/></p> <p>Requires No Lighting: <input type="checkbox"/></p>
--	---	---

- Notes:
- Compliance with future loading requirements mandates doubling all RF antennas listed above when calculating tower loading.
 - All Microwave Antenna Systems use EWP-63 Elliptical Waveguide.
 - All Microwave Antennas are Solid Dish Antennas with a Solid Molded Radome.
 - EWP63 hangers required at the site. 49 Packs of 10

Figure 2-3 Example of a Tower Loading Report

2.12.7 Tower Construction

Tower construction **shall** be performed in accordance with the current edition of ANSI/TIA-222 (or other applicable local Standards body design requirements) or more stringent standard per jurisdiction. Tower construction general requirements are summarized in the following list:

- All personnel climbing a tower **shall** be tied off at all times.
- Antenna mounts **shall** be specified and installed as recommended by the manufacturer. Mounting devices **shall** be made of corrosion-resistant material.
- Qualified personnel certified for the correct installation and safety procedures associated with this type of work **shall** perform the installation.

- The highest point of the antenna and/or lightning dissipater **shall not** exceed the licensed height.

2.12.8 Tower Transmission Cables

Transmission line installation requirements are summarized in the following list:

- Tower lighting cables **shall not** be bundled along with transmission lines or other conductors anywhere within cable ladders or the building interior.
- Each transmission line run **shall** have entry port boots (inside and/or outside), lightning protectors (surge protective devices) and associated mounting brackets, and any additional jumpering required by the site specific RF configuration. Some manufacturers provide transmission line kits, which include the main line connectors, top and bottom jumpers, line grounding kits (typically three per line), hoist grips and weatherproofing materials.
- If the installation requires transmission lines that use air or nitrogen as the dielectric material between the conductors, a dehydration system **shall** be installed to maintain optimum humidity of the dielectric.
- Strain relief devices **shall** be used a minimum of every 60.8 m (200 ft) during transmission line installation and **shall** remain in place to support the cable after installation. A support cable should be used between the grips to prevent damage to the transmission line caused by lifting from only one point.
- Coaxial cable transmission lines **shall** be bonded and grounded in accordance with Chapter 4, “External Grounding (Earthing) and Bonding.”
- To minimize the formation of condensation and ice on transmission lines, a drip loop should be created at the point where the direction of the transmission lines changes from vertical to horizontal (see Figure 2-4). To lessen the likelihood of moisture on the cables getting into the shelter, the cables should be installed with a slight upward incline as they approach the shelter.

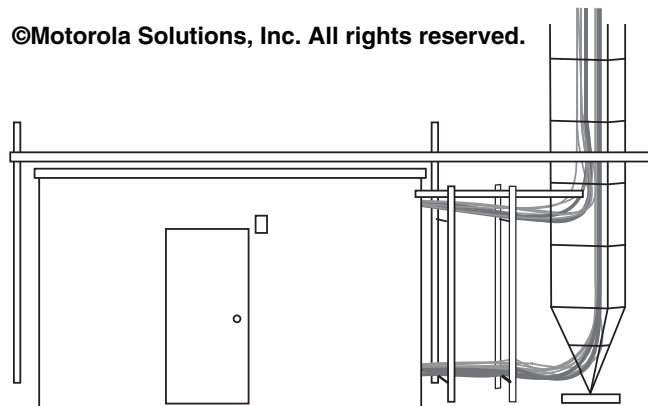

Figure 2-4 Example of Antenna Transmission Line Drip Loop

- Transmission lines **shall not** be installed in a way that will impede climbing or safety devices.
- Transmission lines **shall not** be mounted to climbing ladder rungs or climbing pegs.
- Transmission line installation should be planned with consideration for future expansion.
- Excess transmission line **shall not** be stored (coiled or looped) on the tower.
- All transmission line connectors, splices, terminations and jumpers **shall** be weatherproofed.
- Transmission line **shall** be anchored to the tower using hardware recommended by the transmission line manufacturer for that type of tower. Spacing of anchoring hardware is also determined by the line manufacturer and is dependent on the type and size of the line. Hangers and/or angle adapters are typically provided for every 914 mm (3 ft) of line, including any ice bridge paths. All clamps and hardware **shall** be corrosion-resistant.
- Transmission lines **shall** be identified in a permanent manner using metal tags or equivalent method located at the antenna, at the bottom of the tower, at the shelter cable entrance and inside the shelter or building.

2.12.8.1 Ice Bridge and Cable Support Requirements

The requirements in this section apply to installations using ice bridges and/or cable support systems between the shelter and the tower. These requirements help minimize tower or shelter damage during an earthquake. General requirements are as follows:

- A self-supporting bridge and cable support system **shall not** be mechanically fastened to both the tower and the building, unless a nonconductive slip joint is used at one of the locations. The separation between tower and ice bridge, or building and ice bridge, **shall** be 152 mm (6 in).
- An ice bridge and each support leg **shall** be bonded to the grounding electrode system in accordance with “Cable Bridge/ Ice Bridge Grounding (Earthing) and Bonding” on page 4-108.
- Ice bridges and cable support systems should be adequately supported and constructed from galvanized steel.
- A non-self-supporting ice bridge **shall** be connected with a nonconductive slip joint.

2.13 Site Drawings of Record

All drawings developed in the process of site design **shall** be accurately maintained so that they reflect not only the intended design of the site, but also the way the site was actually built (as-built drawings). Drawings should be marked up to indicate modifications made at the site during construction. A map of the tower installation should also be maintained. Copies of all drawings and other pertinent information to support as-built site design and construction should be provided to the customer.

It is recommended that the responsible party for future installations or upgrades to the site maintain and update the drawings to accurately show all subsequent modifications to the site.

Communication Site Building Design and Installation

This chapter provides requirements and recommendations for designing communications site buildings, including equipment shelters and outdoor cabinets. The following topics are discussed:

- “Site Categories” on page 3-1
- “Definitions of Communications Equipment Sites” on page 3-2
- “Building/Shelter Design and Location Considerations” on page 3-3
- “Foundation Considerations” on page 3-6
- “Floor Loading” on page 3-7
- “Ceilings and Floors” on page 3-7
- “Weatherproofing/Sealing” on page 3-8
- “Heating, Ventilation, and Air Conditioning” on page 3-10
- “Special Considerations for Telephone Central Offices and Switch Rooms” on page 3-13
- “Lightning Damage Prevention” on page 3-13
- “Power Source Protection” on page 3-13
- “Central Office Layout” on page 3-13
- “Cable Trays” on page 3-13
- “Lighting” on page 3-19
- “Fire Protection and Safety” on page 3-20
- “Safety Equipment” on page 3-29
- “On Site Communications” on page 3-30
- “Signage” on page 3-31

3.1 Site Categories

The following list describes typical configurations that could comprise a communications equipment site. See Chapter 4, “External Grounding (Earthing) and Bonding,” for Type A, Type B and Type B2 definitions and site grounding requirements.

- Modules within a single rack: Several frames of radio and support equipment within a general-purpose room, containing other telecom or broadcast equipment.
- Dedicated radio room within a new or existing building: Self-contained outdoor cabinets (land or rooftop) or semi/fully underground vaults. These are often used where zoning or site availability are issues, sometimes in conjunction with camouflaged towers or antennas.
- Prefabricated equipment shelter of concrete/fiberglass construction: The shelter may be installed at an existing tower site, a new tower site or on the roof of an existing building.
- A “shipping container” that has been outfitted as a self-contained radio site must meet strict dimensional requirements, including protrusions, such as HVAC, RF entry assemblies or AC entrances, and **shall** conform to applicable shipping requirements.
- Renovation where an existing building or room is modified or retrofitted to accommodate a new communications system.
- A new site on undeveloped land.

3.2 Definitions of Communications Equipment Sites

This manual defines and distinguishes various site types as described in Table 3-1.

Table 3-1 STANDARD DEFINITIONS OF COMMUNICATIONS EQUIPMENT SITES

Site Type	Description	Notes
Building	A permanent structure built on a foundation, containing communications equipment and related ancillary support systems, and which may contain other unrelated equipment and/or facilities. A building shall be suitable for human occupancy during equipment installation, maintenance and use. A building typically does not have equipment or supporting systems (cable trays, antenna ports, and so on) installed before general installation.	Consists of dedicated site structures as well as interior installations such as shared commercial space in existing buildings, dispatch centers, central office installations and other sites occupied, on a regular basis, by operations-related and possibly other personnel. Example: A dedicated dispatch center and communication equipment site within a dedicated, permanently occupied facility.
Shelter	A permanent structure built on a foundation that contains communications equipment and related ancillary support systems. A shelter shall be suitable for temporary human occupancy during equipment installation, maintenance and use. Example: (See Figure 3-1) A prefabricated building, usually located with a tower or rooftop antenna system, which houses equipment related only to over-the-air communications. The shelter supports personnel only on a limited basis for installation and maintenance functions; a dispatch center would be located elsewhere in this case.	Consists of smaller buildings or prefabricated shelters containing only equipment directly related to the function of the site. A shelter is intended for human occupancy only during equipment installation and maintenance. The Motorola Solutions Standard Building (MSB) is a predesigned all-inclusive self-contained equipment shelter.
Cabinet/ Enclosure	An enclosure that houses communications equipment and ancillary systems only, designed such that equipment contained within can be accessed without the need for personnel to enter the cabinet. An enclosure is typically pre-wired and its equipment is pre-installed. Example: (See Figure 3-2 and Figure 3-3) An unmanned, weather-tight enclosure.	A cabinet/enclosure can be installed indoors or outdoors, placed on a small foundation or wall/pole mounted. A cabinet installed indoors uses the existing building environment (heat and air conditioning) to maintain temperature requirements. An outdoor cabinet contains its own environmental controls.
Vault	An enclosure that houses communications equipment and ancillary systems only and is fully or partially buried in soil. The vault supports personnel only on a limited basis for installation and maintenance functions. Example: Similar to a cabinet/enclosure, except the enclosure is buried below ground level.	Prefabricated shelters, cabinets and vaults may have equipment fully or partially installed prior to building shipment, requiring additional building specifications to allow lifting with equipment installed. Weight and size must be considered if the site has limited access. For shipping, these structures must meet strict dimensional requirements, including protrusions such as HVAC, RF entry assemblies or AC entrances. In the US, state certification may be required if prefabricated buildings are manufactured in a different state than deployed (similar requirements regarding out-of-state or province manufacture may also apply in non-domestic situations).



Figure 3-1 Typical Prefabricated Equipment Shelter

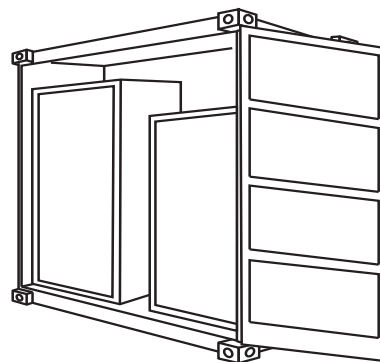

©Motorola Solutions, Inc. All rights reserved.

Figure 3-2 Metal Shipping Container Enclosure



Figure 3-3 Typical Outdoor Enclosure Cabinet on Raised Platform

3.3 Building/Shelter Design and Location Considerations

Prefabricated buildings, shelters, cabinets and vaults may have equipment fully or partially installed prior to building shipment, requiring additional building specifications to allow lifting with equipment installed. Weight and size become a consideration if the site has limited access. For shipping, these structures must meet strict dimensional requirements, including protrusions such as HVAC, RF entry assemblies or AC entrances. In the United States, state certification may be required if prefabricated buildings are manufactured in a different state than deployed (similar requirements regarding out-of-state or province manufacture may also apply in non-domestic situations).

The following are general considerations regarding sites utilizing a new building or shelter capable of human occupancy:

- Consideration **shall** be given to the amount and type of equipment to be housed, along with adequate space for movement and expansion within the structure. The extent of equipment housed will typically determine the suitability of prefabricated structures. See Chapter 6, “Power Sources,” for electrical power sources and Chapter 9, “Equipment Installation”, for equipment installation.
- Equipment configuration typically dictates the structure design. The desired size and composition of a prefabricated shelter **shall** be considered along with weight in transporting the shelter to the site.
- All sites utilizing a constructed structure or a prefabricated structure with manned access **shall** utilize exterior lighting to some extent. See “Lighting” on page 3-19 for specific details on requirements for various categories of structures.
- Always consider not only the initial equipment loading of the site, but also future growth, which may double or triple the initial equipment and/or necessitate additional space at a site. This design should always include the shelter size, air conditioning, UPS, DC battery system, generator and electrical system.
- A “single point” grounding system is required for optimum protection at the site (see Chapter 4, “External Grounding (Earthing) and Bonding”, and Chapter 5, “Internal Bonding and Grounding (Earthing)”, for details). This includes a single ground bus bar located at all of the outside shelter or equipment room penetrations (RF, AC power and generator, GPS, tower light controllers, equipment and phone lines). This design will affect the overall equipment layout. DC power systems should also logically be located close to this ground point. Though this uses up some wall and floor space, it permits the systematic growth of communications equipment outward. See Figure 3-4 for an example.



Figure 3-4 Single-Point Grounding at Entry to Building

- Though not usually required for building foundations, some sites with unique soil conditions may require soil boring tests. Soil borings reveal the soil strength and water content, which are used to design a suitable foundation.
- In earthquake-prone areas (Moment Magnitude rating 3 or greater), foundation design and equipment anchoring **shall** address seismic requirements.
- See Chapter 4, “External Grounding (Earthing) and Bonding,” for information on using concrete encased electrodes (Ufer ground) as a supplemental ground.
- All buildings and shelters **shall** be designed to prevent moisture intrusion and entry of animals and insects into the structure. Design should help discourage nesting of birds and small animals on exterior features of structure.
- Buildings may require compliance with human accessibility standards, such as Americans with Disabilities Act (or equivalent where required). These requirements must be considered during layout and procurement of facility.
- Buildings and shelters should utilize a locked chain-link fence where appropriate and appropriate deadbolt locks on standardized steel doors. Shelters and outdoor equipment cabinets **shall** be of the type designed for electronic equipment housing and accordingly fitted with locking doors.

- Buildings and shelters should utilize an alarm system capable of notifying a remote location of tampering, cable breakage, power outage or system failure.
- When installing equipment racks, it is recommended that those located farthest from the access door be installed in the shelter first, so other equipment can be installed without having to fit it behind existing equipment.
- The current and reasonable future needs of the customer should be understood when considering available equipment enclosures. The customer should be made fully aware of the types of enclosures available.
- Shipping a prefabricated structure to a site may require special road use permits and/or special transportation methods (crane, double-length truck, helicopter and so forth).

3.3.1 Location Considerations

Sites should be selected for construction with the following considerations: cost, limited site preparation, environmental impact, public acceptance, accessibility and future growth.

Rooftop shelters require a structural engineering analysis for both initial and final configurations. Verify that all portions of the access route to the installation site, including stairways and elevators, are also capable of supporting the weight of the enclosure. If the equipment must be lifted to the rooftop by a helicopter it will add significant cost to the project.

3.3.2 Equipment Shelter Off-Loading



CAUTION

To help prevent injury and/or damage to equipment, all appropriate safety precautions **shall** be taken during shelter off-loading.

The equipment shelter type determines the method and means by which it is off-loaded from the truck that transported it to the site. Typically, shelters require extensive rigging and a large hydraulic crane to off-load and set.



IMPORTANT

It is required that all cranes be inspected and tested by crane operator personnel prior to any lift for Motorola Solutions related projects. Construction supervisory personnel shall insist the crane operator demonstrate that the crane has been inspected. Any questions regarding this requirement shall be directed to the Motorola Solutions Project Manager.

3.3.3 Seismic Considerations

In seismically active regions, appropriate seismic design factors must be incorporated into the building or shelter construction or layout. Site locations having a moment magnitude (MM) rating of 3.0 or greater require seismic design standards described in this section and in respective sections of this manual.

US seismic activity maps are available in Uniform Building Code, P. 194, Dia. 23-2, US Seismic Map. Maps and graphs are available on the following US Geological Survey (USGS) web page:

<https://earthquake.usgs.gov/earthquakes>

Also, seismic information can be found using the search function provided on the USGS home page at:

<http://www.usgs.gov>

General seismic information can be found at:

<https://geohazards.usgs.gov>

Also see IBC 2015, chapter 16, for seismic acceleration.

In general, observe the following considerations when designing to accommodate seismic risks of MM 3.0 or greater:

- A qualified architect **shall** be contracted to determine seismic structural needs for a specific location. Proper seismic design of a site helps ensure safety of personnel at the site should an earthquake occur.

- Shelters **shall** incorporate a steel door frame and a steel door for security and seismic integrity. In an earthquake a structure may deform, preventing doors from being opened from the inside. As most communication sites do not have windows, this becomes a serious issue for trapped occupants. Some concrete prefabricated shelter manufacturers also cross-brace the door frame area to prevent deformation during an earthquake.
- Only specifically designed seismic support hardware **shall** be used for seismic bracing.
- Seismic battery racks, seismic bracing and support, and seismic facility and antenna structure construction practices **shall** be employed in seismically active locations. Storage cabinets **shall** be closable and secured to walls.

3.4 Foundation Considerations

- All foundation designs **shall** comply with the guidelines set forth in “Foundation Design and Installation” on page 2-9.
- The foundation **shall** be appropriate for the structure.
- If a site is to use concrete-encased grounding electrodes within the foundation or other concrete structures, appropriate measures **shall** be taken to accommodate the grounding system within a concrete structure before the concrete is poured. See “Concrete-Encased Electrodes” on page 4-23.
- A foundation for a prefabricated shelter **shall** be in accordance with manufacturer's specifications. Prefabricated building manufacturers usually provide typical foundation specifications for their particular model of building.
- A foundation for a cabinet **shall** be level and sealed.
- Design of foundation **shall** consider any special precipitation conditions unique to the installation locality. These considerations include, but are not limited to, elevated (pier type) platforms used in low-lying areas prone to regular flooding and elevated foundations to prevent burial of site due to snowfall. Special foundation designs include:
 - Footings
 - Piers
 - Columns

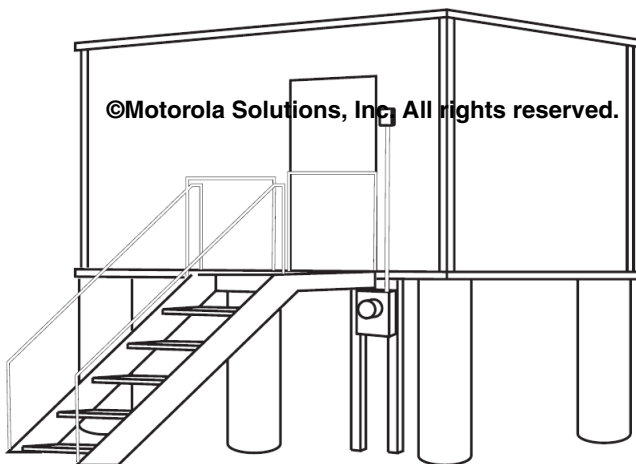

Figure 3-5 Typical Shelter Mounted on Elevated Piers

3.5 Floor Loading

When determining equipment placement in an existing structure or when developing building specifications for an equipment shelter, attention **shall** be given to the Structural Live Load capacity of the building. Standard commercial construction specifications will, in most cases, provide substantial floor loading capacity. However, stacking and/or back-to-back placement of some equipment may exceed structural load limits. The weight and footprint dimensions of each piece of equipment to be installed **shall** be used to calculate floor loading.

The minimum floor loading standard for current Motorola Solutions manufactured equipment is 635 kPa (300 lb/ft² (PSF)). Calculations of the weight of the proposed equipment in PSF **shall** be compared to the rated load carrying capacity of the structure.

Battery configurations can sometimes be specified with feet, rails or specialized load spreading devices that can facilitate deployments in high-rise structures. It is often necessary to specify a battery's location within a prefabricated shelter, such that if the building is staged (fully equipped and optimized) before shipment, the building has enough structural strength to be lifted and transported fully loaded.

Battery configurations with weight exceeding 300 lb/ft² **shall** utilize a specialized load spreading device for the battery rack. Remember to plan for expansion when calculating floor loading.

The civil engineering firm, contractor or architect responsible for designing and/or constructing the site will need data relating to expected floor loading. Typically, the following initial information is required:

- Total weight of the equipment to be installed, determined by adding the individual weights of all electronic equipment, racks and other ancillary support equipment to be installed.
- A diagram showing the amount, weight and proposed location of the equipment planned for installation.

The engineering firm will determine whether the existing floor is adequate, and if not, how the floor can be reinforced to safely support the weight.

The distributed weight **shall not** exceed the rating of the existing floor and **shall** conform to jurisdictional building codes. If an engineering firm is designing the structure, ask their assistance in calculating floor loading.

Some of the practices used to distribute a structural live load can prove to be counterproductive in an earthquake. For example, steel I-beams are sometimes used to support a modular shelter between parapet walls of a high rise building, where the roof itself could not handle the weight without costly retrofit. In an earthquake, the I-beams will flex to their limits with the moment of the shelter movement. Rooftop isolators attached between the roof surface and the I-beam supports can dampen the movement of the shelter, absorbing the energy of an earthquake.

3.6 Ceilings and Floors

For Tenant Improvements in existing high-rise buildings, it is critical that the contractor determine if post-tensioning is employed in floor, roof or wall construction. If so, industrial X-ray mapping **shall** be employed to avoid structural damage caused by accidental penetration of a tensioning cable.

3.6.1 Ceilings

The following general considerations must be observed when designing a site building, selecting a prefabricated shelter or installing equipment in an existing structure or room:

- Ceiling height **shall** conform to applicable jurisdictional building codes.
- Minimum acceptable ceiling height for communications sites utilizing 2.2 m racks (standard 7.5 ft rack) are recommended to be 2.75 m (9 ft).
- When adding equipment to existing sites, ensure that the ceiling is high enough to accommodate the planned additional equipment, including stacked cabinets.
- Determine the height of the tallest rack that could be deployed at a site, and then provide additional height to accommodate cabling, working room and ventilation.

- Consider the size of the cable that might be attached to the top of the rack and that cable's bending radius. Typically the cable tray will be a minimum of 152.4 mm (6 in.) above the tallest rack or cabinet.
- The cable tray should be installed to provide at least 305 mm (12 in.) clearance between the cable tray and the ceiling (ANSI/TIA-569-C).
- In a site where the existing ceiling is too low to accommodate the specified clearances, the location of the cable tray may be moved to above the aisle behind the equipment row. Good site engineering practices must be considered, including accommodation of any electrical and working spaces.

3.6.2 Floors

Observe the following general considerations when designing a site building or selecting a prefabricated shelter:

- Floor construction **shall** conform to applicable jurisdictional building codes.
- Except for access flooring, floors should be constructed of concrete or wood. Normally if the building shelter floor is at ground level, the floor is concrete. If the building shelter is elevated from ground level, the floor is normally constructed of heavy duty floor joist and plywood or a cement/wood composition board (commonly known as Viroc[®]).
- Concrete used as communications site flooring **shall** be properly mixed to ensure adequate tensile strength under load.
- Concrete **shall** be poured and reinforced in accordance with applicable jurisdictional requirements. Where an earthquake-resistant structure is specified, additional considerations may apply.
- Floors **shall** be level before equipment is installed.
- If a wooden floor is to be used, ensure that the contractor's floor loading calculations take into account the type of equipment that will be installed, plus any future equipment. (See "Floor Loading" on page 3-7).



CAUTION

Equipment racks **shall not** be secured with screw lags into plywood alone.

- Floors **shall** be sealed to minimize the generation of airborne particulates (ANSI/TIA-569-C). This is extremely important for a long equipment service life. Concrete and wooden floors may be finished using vinyl flooring. Concrete floors may also be sealed with an epoxy coating or equivalent.
- Anti-static vinyl flooring is available for installations where equipment is vulnerable to electrostatic discharge (ESD). Care **shall** be taken when installing this type of flooring to ensure the integrity of the anti-static properties. Consult a contractor experienced with this type of flooring. See Appendix C, "Protecting Against Electrostatic Discharge in Equipment Rooms and Dispatch Centers", for more information.

3.7 Weatherproofing/Sealing

3.7.1 Transmission Line Entry Ports

Appropriate methods for entry of transmission lines into a building or shelter are as follows:

- An entry port specifically designed for cabling.
- Non-metallic conduit, typically 102 mm or 127 mm (4 to 5 in.) diameter, allowing 50.8 mm (2 in.) protrusion at ends. If a non-metallic conduit is used, it **shall** be sealed using an appropriate all-weather silicone sealant between the conduit and the wall. The free space between the cables and the inside of the conduit should be packed with appropriate fiberglass or foam insulation.
- Roof/wall feed-through.

In general, observe the following considerations for sites utilizing transmission line connections from an interior area to the exterior of a building or shelter:

- The entry of antenna transmission lines into a communications building or room requires a weatherproof, commercially made port assembly specifically designed for this purpose. These assemblies typically consist of a transmission line entry plate and boot assembly.
- A boot **shall** be used even if the cable is run through conduit. To avoid inconvenient rework in the future, it is recommended to select a transmission line entry plate with enough ports to accommodate the number of transmission lines at the site and allow for expansion.
- Entry plates should have 102 mm or 127 mm (4 or 5 in.) diameter openings. The plate is usually made of painted aluminum, with from one to 12 ports per plate. A single entry plate mounted on the outside wall or bulkhead is sufficient. See Figure 3-6.
- Cable boots corresponding to the cable diameter(s) **shall** be used. Cable boots are sized for the transmission line they will carry and can be round, oval or rectangular. Some cable boots allow up to three small (12.7 or 22.2 mm (0.5 or 0.875 in.)) transmission lines to enter through one boot. The boot is usually made up of a two-piece cushion jacket, cushion (sized to cable diameter) and clamp set.
- To reduce heat loss from the building, two entry plates should be installed inside and outside, with rigid construction foam insulation between them (two sets of boots are then required).
- The entry plate **shall** be installed per the manufacturer's instructions.
- The building/shelter and the port attachment to the building/shelter, **shall** be designed to prevent animals or birds from nesting in and around the entry ports.
- Transmission line entry ports **shall not** be used to feed through tower light power, building ground or control cables.
- Boots **shall** be made of a material unaffected by ozone, sunlight, extreme heat and cold.
- All unused ports in the entry plate **shall** be sealed with blank caps supplied by the port manufacturer.
- If a metallic port is used, it **shall** be bonded to the grounding electrode system. An integrated cable port **shall** be bonded to the external grounding electrode system.



Figure 3-6 Typical Entry Plate

3.7.2 Sealing of Buildings and Shelters

All site buildings **shall** be weather tight and **shall** deter entry by animals, birds, and insects.



WARNING

Buildings and shelters that may have been open to the elements and animal infestations can pose health risks to personnel working in the structure. Avoid sweeping dry floors when rodent droppings may be present. Personnel occupying the site SHALL wash hands before eating and avoid touching mouth, nose or eyes until site is sufficiently clean.

- Animals and insects pose a threat to equipment and can cause health hazards to personnel. Accumulated rodent droppings can harbor hantavirus and other diseases. Hantaviruses are deadly airborne viruses spread by rodents. This threat **shall** be considered even more significant at remote sites in rural areas. Hantavirus infection can prove fatal in a few days without aggressive medical treatment. The best way to prevent hantavirus infection at a site facility is to assure that all site facility exterior openings are sealed. Floors in site facilities in rural locations should never be swept clean, but should be wet mopped to prevent airborne hantavirus contamination. A good practice when working at remote sites is to wash hands frequently and avoid touching your mouth and nose. To prevent the spread of disease and to prevent damage to equipment caused by nesting wildlife, observe the following requirements:
- If rodents are present within a site building or enclosure, the affected area **shall** be appropriately cleaned in a manner that is safe to personnel. Appropriate preventive measures **shall** be taken to remove and prevent further infestations. To prevent hantavirus infection, the floor **shall** be mopped in a safe and sanitary manner using a 5:1 water/bleach mixture.

For additional information on controlling the spread of hantaviruses, see the Centers for Disease Control website:

<http://www.cdc.gov/hantavirus>

3.8 Heating, Ventilation, and Air Conditioning

One of the major considerations in site development is to maintain an environment in which the equipment can operate efficiently. A properly designed Heating, Ventilation and Air Conditioning (HVAC) system provides the proper environmental conditions. The ambient temperature and humidity within the building or equipment room **shall** be maintained within the range specified by the manufacturer of each piece of equipment. All products manufactured by Motorola Solutions, as well as outsourced items that are drop-shipped per Motorola Solutions orders, have temperature, humidity and cleanliness requirements, as listed in their respective manuals.

Equipment manuals may specify either operating or ambient temperature. Operating temperature refers to temperature within the equipment case, with the equipment operating at a given capacity or load. Ambient temperature refers to the environmental temperature as typically measured 1.5 m (5 ft) above the floor in the center of an adjacent aisle.

In lieu of manufacturer environmental standards, the site HVAC system **shall** be capable of maintaining interior conditions of 18° to 27° C (64° to 81° F) (ASHRAE recommendation) and reduce humidity to a level of 40% to 55% relative humidity (RH) (ATIS-0600321.2015).

The variables involved in maintaining ambient temperatures include, but are not limited to, the following:

- Building construction
- Building size
- Type and amount of equipment installed at the site
- Ambient outside temperature
- Room size
- Number of entry ports (windows, doors, transmission line entry ports)
- Insulation
- Roof type (slope and construction material)
- Surrounding structures
- Use of a forced fresh air system
- Geographical location of the site

Design considerations should be made for equipment deployments and locations concerning operating limits of the equipment should the HVAC provisions fail. The facility backup generator **shall** be sized to accommodate the HVAC system.

With generator systems, a start-up delay kit is recommended on the HVAC system so that site AC power cycling or stand-by generator cut-over does not present a drop-out/brown-out condition which could stall and damage HVAC compressors.

The type and number of HVAC units required **shall** be calculated accurately. Due to the large number of variables involved, a single HVAC specification cannot be applied to all situations. Sizing of the HVAC system **shall** be performed by a HVAC engineering firm or the equipment shelter manufacturer's engineer.

3.8.1 HVAC Design Considerations

The HVAC requirements for each site **shall** be evaluated on a site-by-site basis. It is advisable to include an expansion factor of at least 25% in the planning calculation, with consideration given to the final growth potential. With prefabricated buildings, provisions in the wall structure can sometimes be made such that another unit can be added in the field for additional growth.

Consider the following when working with the HVAC contractor to design the HVAC system:

- Obtain thermal loading for each piece of equipment from the appropriate engineering personnel and provide it to the building manufacturer HVAC engineering or HVAC contractor. Motorola Solutions System Planners typically provide heat generation information in BTU and Watts.
- Obtain site specifications for construction materials, insulation type and R values, size, existing conditions and predicted growth.
- In areas with a history of Moment Magnitude rating 3 or greater, seismic considerations for the HVAC system **shall** be addressed by the HVAC engineering firm or contractor. Typically, additional flexible bracing can be provided to prevent HVAC equipment from tipping or shifting position. Flex hoses or semi-rigid hoses with strain relief should be provided to prevent mechanical stress failure.
- Only HVAC equipment that uses chlorofluorocarbon-free (CFC-free) coolant **shall** be used for new installations.
- It is recommended that the HVAC system be alarmed. If the site has an alarm system, each HVAC unit installed at a site **shall** be connected to the building alarm system, so that the total shutdown of any HVAC unit results in an alarm.
- HVAC filters **shall** always be used and maintained on a regular schedule in order to maintain a clean environment and prevent dust and contaminants entering into electronic equipment.

3.8.1.1 Wall-Mounted HVAC Units

Observe the following general considerations for wall-mounted HVAC units (see Figure 3-7 for an example):



Figure 3-7 Typical Commercial Wall-Mounted Air Conditioning Unit

- Self-contained wall mounted HVAC units are acceptable in most applications, but use care in selecting the proper unit size for the projected BTU heat load. If more than one unit is required, plan to provide sufficient wall mounting space.
- Only commercial-grade HVAC units **shall** be used. Consumer-grade household units or window-mounted units **shall not** be used.
- To reduce operating costs and prevent the compressors from freezing during cold weather, all units should be equipped with heating elements and an economizer which allows the site to be cooled by outside air if the outside temperature falls below a predetermined value.

- HVAC systems using outside air circulation features may not be suitable for environments having unusually high dust, high humidity or particulate emissions.
- Redundant HVAC units **shall** be installed and available as a backup in case one unit fails or a single unit may be used if it is alarmed to a remote terminal. All redundant HVAC units should be designed in a lead-lag configuration to cycle with the primary unit in order to subject all units to equal wear.
- If two HVAC units are required to provide sufficient cooling, one additional unit should suffice for redundancy.
- Local fire codes may require an automatic shutdown circuit for HVAC units should the smoke/heat alarm activate.

3.8.1.2 Exhaust Fans

- It is advisable to install a thermostatically-controlled exhaust fan at some sites, to remove excessive heat buildup if air conditioning units are disabled or fail.
- Locate the exhaust fan as high as practicable in the structure to remove the maximum amount of heat.
- A corresponding filtered exterior cold air inlet vent with motorized louvers should be installed low on an opposing wall to allow unobstructed air flow through the site.
- The inlet of the fan **shall** be protected with a screen barrier to prevent the entry of insects, birds or animals.
- To prevent excessive dirt and/or humidity from entering the building, the exhaust fan is intended to be used only as an emergency backup.
- Battery and generator rooms require special concerns regarding exhaust requirements. See “Battery Systems” on page 6-31 for additional information.
- Louvered entries into buildings or shelters may present a security risk due to ease of unauthorized entry through the louver assembly. This concern should be considered in the overall security plan for the site.
- Design of motorized louver systems **shall** comply with NFPA shutdown requirements. Exhaust fans and HVAC systems **shall** automatically shut down and the exterior wall vents automatically close during fire alarm activation and fire suppressant release. See NFPA 12 for additional information.

3.8.1.3 Heat Pumps

In sites where heat levels are too high for the use of wall-mounted units, commercial-grade heat pumps may be used. Appropriateness of using a heat pump system **shall** be determined by the contracted HVAC engineering firm or contractor. Heat pumps are also used in shared sites or where an exterior wall is not available for installation of a stand-alone HVAC unit. The compressor is separate from the control units and **shall** be mounted on either a pad on the roof of the structure or on a concrete pad outside the building.

Per NFPA 70-2017, Article 210.63, a 15- or 20- ampere-rated receptacle outlet is required for maintenance of the heat pump. A ground fault circuit interrupter (GFCI) receptacle is also required within 7.5 m (25 ft) for maintenance. All units should be equipped with a start control option to avoid compressor damage during short power outages.

3.8.1.4 Thermostats

Thermostats **shall** be installed in locations where room ambient temperature can be best and most evenly controlled. The placement and number of thermostats should be determined by the contracted HVAC engineering firm.

3.8.1.5 Temperature Alarm

To avoid down time and possible equipment damage due to temperature extremes, it is recommended that all sites be equipped with high and low temperature alarms. These alarms should interface with the site security system and be monitored around the clock. The sensors **shall** be accurate enough to detect temperature variations within the range of 5° to 33° C (40° to 90° F).

3.8.1.6 Maintenance

It is recommended that the customer establish a preventive maintenance program with an authorized local HVAC service company or with Motorola Solutions to provide service and repair. The agreement should include periodic cleaning and filter replacement. The back-up HVAC unit should be periodically exercised, or alternatively, an equal-sharing duty cycle can be used.

3.9 Special Considerations for Telephone Central Offices and Switch Rooms

The same building design requirements for general communications sites apply to switch room, iDEN Mobile Switching Office (MSO), major dispatch centers or central office (CO) design, but on a more critical scale. For example, a CO may contain a cellular or Personal Communications Services (PCS) switch and/or centralized base station controllers. Good design is even more critical for a CO because the CO can be the overall controlling entity of an entire system, and thus can cause system-wide failure if there is a problem.

3.9.1 Lightning Damage Prevention

Although perhaps more costly, the most effective way of protecting the CO switch from lightning damage is to locate it separately from a communications site and accompanying tower at the same facility. Not only is the CO switch much more expensive to replace than typical communications equipment, but the entire system will fail if the CO switch fails. The initial extra cost of building a separate communications site at the CO location is far less expensive than revenues lost if the entire system fails due a damaged CO switch caused by a lightning strike to the radio tower.

3.9.2 Power Source Protection

- Ideally, it is preferable to have separate, redundant power feeders from the power company serving the switch room. These should be fed from two different substations, so that the failure of one substation will not cut off power to the CO.
- Co-located business office function may also be considered with priority. Because most CO equipment is served by DC power systems, a large battery system, perhaps even in a redundant configuration, should be considered. This not only provides backup power in case of generator failure, it also provides a means of absorbing surges on the DC circuits that may occur if the site has to switch to generator power.
- Terminals communicating with the switch can be served by either individual UPS plants or a centralized, overall system. This keeps switching transients from interrupting terminal operation.
- Surges transferred over the power lines during normal operation **shall** be drained by primary and secondary surge suppressors installed in a configuration that accommodates the generator circuits. See Chapter 7, “Surge Protective Devices.”
- It is recommended to have a CO, Dispatch center, and so on served by optical fiber cables with T-1, T-3, OC-3 and higher capacities. This provides additional lightning protection by removing the copper connection from the phone company to the switch and provides optical isolation from ground potential rises that can occur on the copper connections.

3.9.3 Central Office Layout

When first installing equipment into a new large switch room, the equipment layout **shall** be planned to allow for sufficient aisle space, but be efficient so future expansion capacity is maximized. The initial layout should be designed to accommodate the absolute maximum number of equipment racks while allowing adequate space between aisles and at end of aisles.

Minimizing the overall distances of the DC power system and the grounding layout should be a priority.

The control room housing the switch terminals should be isolated from the rest of the equipment to provide noise reduction for those continually working in this environment.

3.10 Cable Trays

This section provides requirements and installation guidelines for cable trays. Cable trays should be used to support communications cabling within buildings and shelters.

Cable trays provide proper support of cables between cabinets, relay racks and bays of equipment and help maintain adequate separation between the cable groups. The orderly separation and support of cable also simplifies maintenance. Cable management over relay racks and equipment cabinets can be accomplished by utilizing cable tray systems. These tray systems are designed to provide support, routing, parallel separation and securing of wires and cables as defined in “Cable Installation Within Cable Trays or Ladders” on page 9-30. As defined in NFPA 70-2017, Article 392, a cable tray or tray system is a unit or assembly of units or sections and associated fittings forming a rigid structural system used to securely fasten or support cables and raceways. See Figure 3-8 for examples.

**IMPORTANT**

Aluminum ladders designed for climbing shall not be used as cable trays.

3.10.1 Cable Tray Selection

Two types of overhead cable tray systems which are suitable for use as cable support are:

- Steel stringer style ladder
- Aluminum or steel ladder style cable tray

Steel stringer style ladders come in various designs and styles. Typically they are available in C-channel, tubular and solid bar in painted or yellow zinc dichromate finishes. Stringers are typically 38.1 mm (1.5 in.) to 51 mm (2 in.) in depth and vary in length. Rungs should be spaced at least 229 mm (9 in.) apart. Simple hardware is used to make “T” and cross connections.

“J-bolts” (threaded, formed metal rods bent into a “J” shape) **shall not** be used as fasteners for cable trays. These rods typically deform when stressed, possibly allowing cable trays to drop. Captive hardware, such as threaded bolt, washers and nuts, is recommended.

Aluminum or steel cable tray systems also come in various designs and styles such as ventilated trough, solid trough and ladder type with “I” beam or C-channel siderails. The most practical is the ladder type. The major difference between the stringer style ladders and tray systems is that a tray has a siderail or wall height from 102 mm (4 in.) to 178 mm (7 in.). This load depth may be desirable for large bundles of cables or transmission line routing. The siderail height affects overall rack to cable tray to ceiling dimension restrictions as outlined in this chapter. A rung spacing of 229 mm (9 in.) is also recommended for this tray type. This type of tray system requires prefabricated Ts, bends, crosses and reducers, which must be factored into the system design.

Both types of tray are available in widths ranging from 102 mm (4 in.) to 1.06 m (42 in.). Typically, widths of 457 mm (18 in.) and 610 mm (24 in.) are used. Stacking of 457 mm (18 in.) wide trays is allowed, but ceiling height requirements and clearances **shall** be adhered to. Cable support system design **shall** provide for maintaining a spacing of 457 mm (18 in.) between trays.

The overall sizes of cables, numbers of cable and number of cable groups required in a run **shall** be considered when specifying tray width. Account for a minimum of 152.4 mm (6 in.) loss of width for cable group spacing in itself.

**NOTE**

In all cases the width of the cable tray **shall not** be less than 457 mm (18 in.) and is recommended to be 610 mm (24 in.).

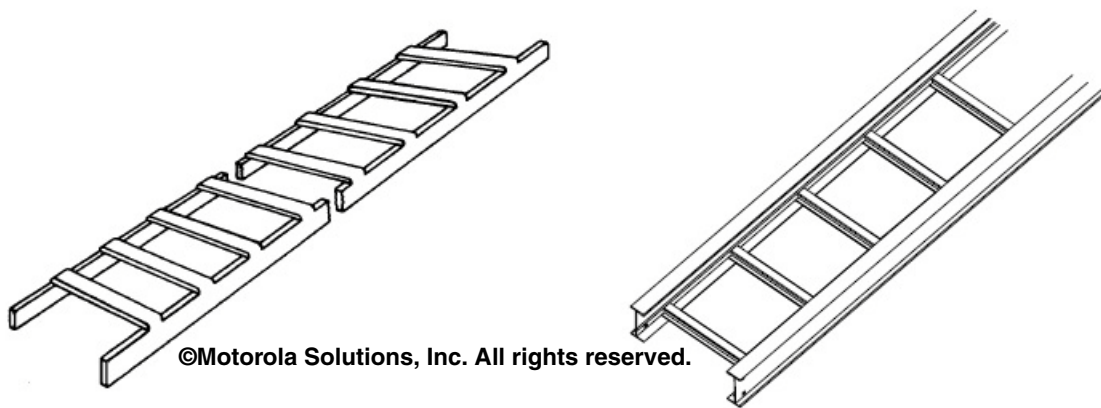

©Motorola Solutions, Inc. All rights reserved.

Extruded Aluminum Types



©Motorola Solutions, Inc. All rights reserved.

AC receptacles supported from raceway, not cable tray.

Solid Steel Painted Type



©Motorola Solutions, Inc. All rights reserved.

Flexible Steel Wire Type

Figure 3-8 Typical Cable Runways

3.10.2 Cable Management Under Raised Floors



NOTE

Do not mix aluminum and steel tray types at a facility installation.

For wire management under raised computer floors, a welded wire mesh cable tray system is recommended. This type of tray system can be mounted to, or suspended from, raised floor pedestals or sub flooring. This tray system typically consists of high strength steel wire in the form of a 50 x 100 mm (2 x 4 in.) mesh. The finishes can be electro-plated zinc galvanized or stainless steel that are suitable for all environments. Bends can be fashioned by cutting the mesh with a bolt cutting tool and simple hardware connections to the wire mesh. Manufacturers can supply bonding terminations and outboard ground cable supports for proper tray system grounding and bonding.

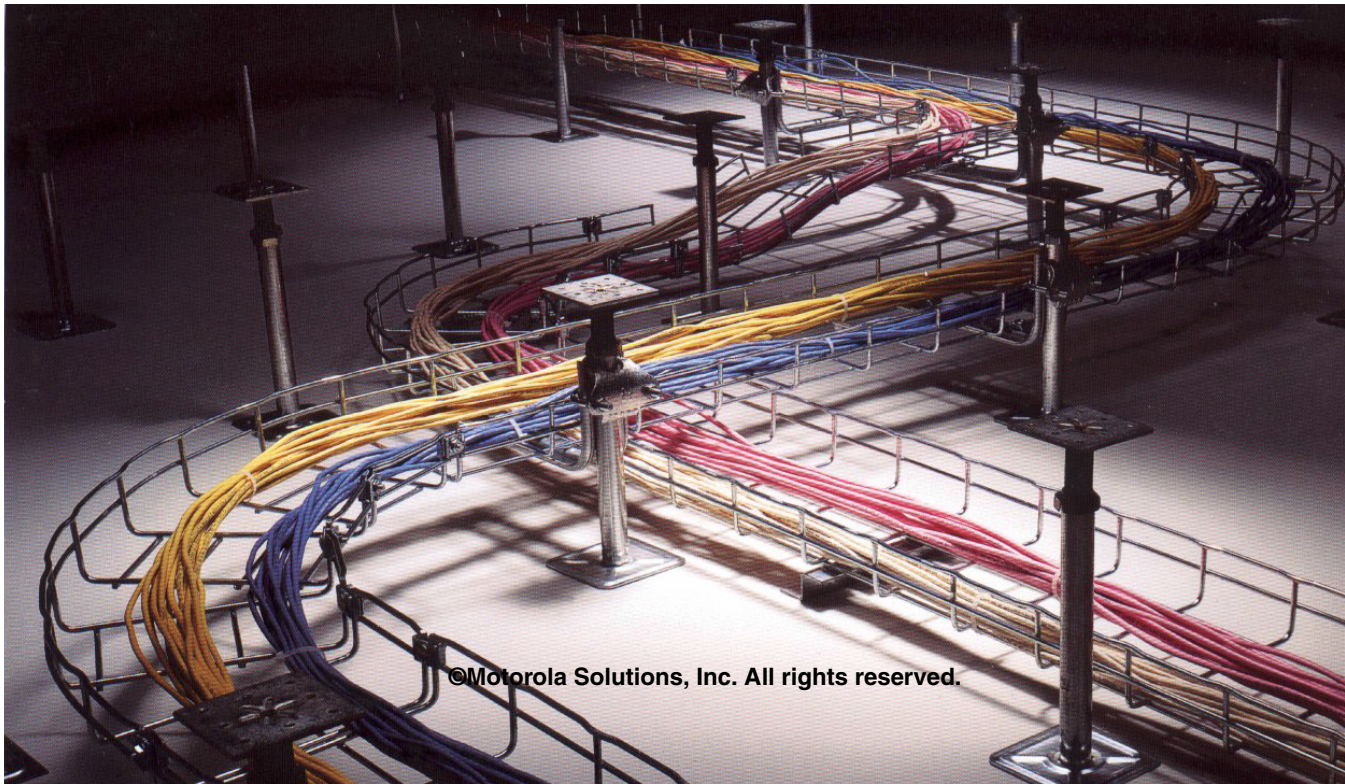

Figure 3-9 Typical Wire-Mesh Runway

3.10.3 Wire-Mesh Cable Trays

In general, observe the following when selecting and installing wire-mesh cable trays:

- The cable tray **shall** be listed.
- The cable tray **shall** be installed per the manufacturer's instructions.
- The cable tray **shall** be supported at the required intervals, as per the manufacturer instructions.
- The wire mesh tray should be listed for use as an equipment grounding conductor.
- The wire mesh tray sections **shall** be joined using manufacturer approved fastening hardware.
- The wire-mesh tray **shall** be bonded to the Internal Bonding and Grounding system (see Chapter 5, "Internal Bonding and Grounding (Earthing)", for more information).

3.10.4 Cable Tray Layout and Design

In general, the following considerations must be observed when preparing the layout of cable trays:

- Noting the amount of cables to be supported by each run, cable tray width **shall** be selected to provide 50.8 mm (2 in.) minimum separation between cables or cable groups. 457 mm (18 in.) trays or double-deck ladders may have to be used in some cases.
- The size, weight and projected expansion of the system **shall** be considered to ensure proper tray usage.
- The number and function of conductors to be placed within a cable tray **shall** be considered before procuring cable trays.
- It is recommended that only cable trays specifically designed for communications purposes be used (as opposed to standard electrical cable trays).
- The cable tray system **shall** use the proper sections as designed by the manufacturer. Straight sections, elbows, tees, dropouts and expansion connectors **shall** be used as required within the system.
- The cable tray system **shall** be designed with suitable strength and rigidity to provide adequate support for all contained cabling.
- Due to thermal contraction and expansion, cable tray systems may require the use of expansion connectors.
- If the building has a sprinkler system, ensure the cable trays do not block the sprinklers. Cable trays **shall not** be placed under smoke detectors or sprinkler heads.
- The cable tray system **shall** be designed to accommodate cable distribution throughout the equipment area. Continuity of the cable tray system and support for the cables **shall** be maintained.
- Cable trays and troughs may extend through walls or floors providing the installation is made so that the possible spread of fire or products of combustion will not be substantially increased.
- Openings through fire resistant walls, partitions, floors or ceilings **shall** be firestopped using an approved method to maintain the fire resistance rating.
- Cable tray systems **shall** be designed for installation at heights that provide clearances adequate to install the necessary equipment with provisions for expansion.
- Factors such as ceiling height, light fixture locations, cable entry ports, equipment location and minimum cable bending radius must be considered during design and layout.
- Cable trays should not be placed under lights or electrical fixtures or boxes.
- A minimum of 152.4 mm (6 in.) between the top of an equipment rack/cabinet and the bottom of the cable tray **shall** be maintained where practicable.
- A minimum of 305 mm (12 in.) above the top of the cable tray and the ceiling **shall** be maintained (ANSI/TIA-569-C), where practicable. Both of these dimensions are required at all new sites. If at an existing site with a lower ceiling, good engineering practices are required.
- When AC power distribution is to be combined with the cable tray system, the AC power raceway **shall not** be supported by or supported from the cable tray system **unless** the cable tray system is manufactured and approved for this purpose. The AC power raceway may be supported by a trapeze arrangement with the cable tray attached to the top of the trapeze and the AC power raceway attached to the bottom of the trapeze. The trapeze arrangement is supported from the ceiling and/or sidewalls.
- Steel stringer and steel tray systems may utilize an extended post for attaching grounding conductors outside the tray. This post should extend 102 mm (4 in.) to 152.4 mm (6 in.) either horizontally or vertically from the siderail of the tray, with no less than 457 mm (18 in.) of spacing between posts.
- A solid bottom cable tray with a hinged cover may be desirable for use between a tower and building, to provide complete enclosure of the cables and minimize the potential for damage and vandalism. Unless specifically designed to also function as an ice bridge, a cable tray **shall not** be used instead of a standard ice bridge.

3.10.5 Cable Tray Installation

Observe the following general considerations when installing cable trays:

- The entire system **shall** be rigid, immovable and properly secured in place.
- The cable tray system **shall** be installed per the manufacturer’s specifications, NFPA 70-2017, Article 392, and local codes.
- Cable trays **shall** be securely supported to the ceiling and/or wall such that they are immovable. These supports **shall** provide a strength and working load capacity sufficient to meet the load requirement of the cable tray system.

**NOTE**

Cable trays **shall not** be supported by equipment racks.

- Horizontal and vertical supports should provide an adequate bearing surface for the cable tray and should have provisions for hold-down clamps or fasteners. There may be additional requirements for active seismic areas (Moment Magnitude 3 or greater), such as wooden headers at wall connections. It is recommended in these cases that cable tray ends be attached to walls using a 50.8 mm x 102 mm (2 x 4 in.) wooden header. The header may be nailed along the wall approximately 305 mm (12 in.) below the ceiling. This provides a blunt attachment point which will prevent the somewhat sharp ends of cable trays from penetrating the walls. Seams between multiple cable tray sections run across a room should be staggered so that if a seam fails, the entire cable ladder system will not fail.
- A support **shall** be located within 610 mm (2 ft) of each side of an expansion connector. Cable tray systems **shall not** be used as incidental support for other raceways or equipment.
- Cable trays **shall** be positioned such that they are easily accessible with sufficient space provided above and around the cable tray to permit adequate access for installation and maintenance of cables.
- Cable trays **shall not** have any sharp edges, burrs or projections that may damage cables.
- All cable tray sections **shall** be electrically bonded together by an approved method and connected to the building ground system. See Figure 3-10 and Chapter 5, “Internal Bonding and Grounding (Earthing)”, for additional information.

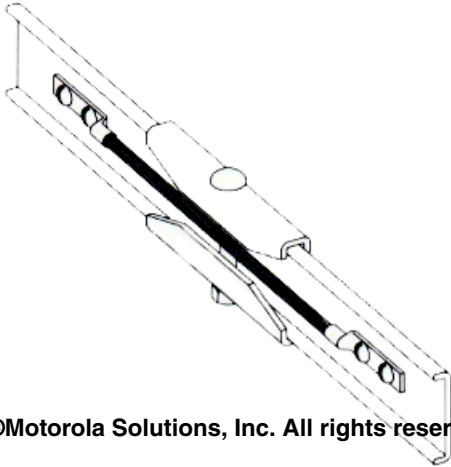

©Motorola Solutions, Inc. All rights reserved.

Figure 3-10 Cable Tray Bonding Conductor

3.10.6 Cable Tray Safety Considerations

The following cable tray safety considerations **shall** be observed:

- Cable tray systems **shall not** be installed at heights or in positions that pose a hazard to service personnel working within the site.
- At no time **shall** the cable tray system be used as an incidental support or walkway.
- Threaded support rods **shall not** extend below the tray bottom further than the required fittings and **shall** include appropriate protective end caps.

3.11 Lighting

All lighting **shall** follow the applicable requirements of NFPA 70-2017, Article 410, and any other applicable national, state, jurisdictional and local code requirements. Interior lighting requirements are based upon a number of considerations, including:

- Adequate lighting for a safe and efficient work environment. Placement should assure illumination behind tall rack cabinets.
- Energy efficient design
- Low heat generation characteristics
- Exterior lighting requirements are concerned with lighting for points of entry and exit from the building and for perimeter security.
- Lighting on remote sites can be seen for miles at night and in some cases, may cause objections from neighbors. To address these issues, on-demand systems such as infrared proximity sensors and twist-knob timers are highly recommended. Bright lights (including lights used on photocell controllers) can, in some cases, produce neighbor and environmentalist complaints.
- In all cases, incandescent, fluorescent or Light Emitting Diode (LED) lighting may be used.

3.11.1 General Interior Lighting Specifications

In locations that are considered hazardous because the atmosphere does or may contain gas, vapor or dust in explosive quantities, special application fixtures **shall** be used. These fixtures **shall** be rated for use in areas classified as Class I, II and III and Division 1 and 2, as applicable. These fixtures **shall** comply with NFPA 70-2017, Articles 500 through 506.

In applications where fixtures are susceptible to being dislodged or where tube breakage may represent a hazard to personnel or equipment, shatterproof fluorescent tubes or safety tubes **shall** be used. Seismic and industrial practices require that fluorescent lamp protectors be installed over lighting to prevent falling glass or accidental damage to lamps.

If incandescent lighting is used, industrial-grade protective covers **shall** be used.

3.11.2 Interior Lighting Quality

Interior lighting **shall** produce a minimum of 500 Lux (50 foot-candles) measured 1 m (39.4 in.) above the finished floor in the middle of all aisles between cabinets or racks. See ANSI/TIA-569-C for additional information.

3.11.3 Emergency Interior Lighting

- All emergency lights **shall** be UL approved and meet all OSHA, NFPA 101, and any other applicable national, state, jurisdictional and local life safety code requirements.
- Emergency backup lighting units **shall** be installed to activate immediately upon loss of all AC power in all equipment shelters and tenant improvement equipment rooms within a building.
- Each unit **shall** be equipped with a self-test button or switch.
- Each unit **shall** have a minimum of two lamps.
- Batteries **shall** be sealed and maintenance free and **shall** provide a minimum of 90 minutes of emergency power.
- Emergency lights installed in harsh environments **shall** meet all requirements for NEMA 1, 2, 3, 3R, 3S, 4, 4X and 12 ratings.
- The lights **shall** be located to illuminate any and all doorways and exits.
- Exits **shall** be labeled with illuminated signs reading EXIT. Pathways to exits **shall** be marked.
- Emergency lighting within high-rise buildings may require that it be powered from a house power source and that the emergency lighting be connected to the house master alarm system.

3.11.4 Exterior Lighting

- One exterior light **shall** be installed near the door to provide lighting for personnel entering and exiting an equipment shelter. The fixture **shall** be type NEMA 3, weather resistant and suitable for general outdoor application.
- If floodlights are installed to provide yard/perimeter security lighting, the following requirements **shall** be met:
 - UL approved Quartz, High Pressure Sodium or Light Emitting Diode (LED) lighting elements **shall** be used.
 - Mercury Vapor and Metal Halide lamps **shall not** be used. These lamps can cause serious skin burns and eye inflammation from short-wave ultraviolet radiation if the outer envelope of the lamp is broken or punctured.
 - An automatic photo-control switch, with a manual override, can be used to turn the lights on at dusk and off at dawn if desired.
 - Fixtures **shall** meet NEMA heavy duty type classification and be UL (or equivalent) listed for use in wet locations.

3.12 Fire Protection and Safety



WARNING

The primary intent in suppressing a fire at a communication site is to protect lives. Equipment protection is secondary. If the fire is expected to be entirely suppressed by a manual extinguisher, then the suppression effort can be made, but in no circumstances shall fire suppression be attempted in order to save equipment when personnel safety is at risk. In all cases for occupied shared buildings, the fire department and tenants shall be notified immediately of the fire.

Fire extinguishers can represent an important segment of any overall fire protection program. However, a proper fire suppression program success depends upon the following general conditions:

- The extinguishers are of the proper type and size for a fire that may occur.
- The extinguishers are properly located and identified.
- The extinguishers are in working order and properly maintained.
- Employees have a clear understanding of their functional operation.
- Safety awareness has been made available.

3.12.1 Reference Publications

The following are suggested reference publications regarding fire suppression systems:

- NFPA 1: Fire Code
- NFPA 10: Standard for Portable Fire Extinguishers
- NFPA 12: Standard on Carbon Dioxide Extinguishing Systems
- NFPA 13: Standard for the Installation of Sprinkler Systems
- NFPA 17: Standard for Dry Chemical Extinguishing System
- NFPA 2001: Standard on Clean Agent Fire Extinguishing Systems
- CAN4-S503-M83: Standard for Carbon Dioxide Hand and Wheeled Fire Extinguishers
- CAN/ULC--S504-12 Standard for Dry Chemical Fire Extinguishers
- UL 154: Carbon Dioxide Extinguishers
- UL 299: Dry Chemical Extinguishers
- UL 711: Rating and Fire Testing of Fire Extinguishers

3.12.2 Training and Proper Usage

Site personnel **shall** be familiar with the proper usage of the fire protection equipment provided at the site. Documentation supplied with the equipment **shall** be made available to personnel. Responsible personnel **shall** fully understand the content of such documentation.







More complicated systems, such as an installed automatic system, should be supported with training supplied by the vendor.

3.12.3 Fire Classifications

The following fire classifications and information on portable fire extinguishers was acquired from the National Fire Prevention Association literature NFPA 10. For additional information on the classification of extinguishers and hazards, refer to NFPA 10 or applicable jurisdictional/local fire codes.

In general, fires are classified according to the type of combustible material that is consumed. The types are as follows:

Table 3-2 FIRE CLASSIFICATIONS

Class	Symbols		Description
Class A Fire			Fires in ordinary combustible materials, such as wood, cloth, paper, rubber and many plastics.
Class B Fire			Fires in flammable liquids, combustible liquids, petroleum greases, tars, oils, oil-based paints, solvents, lacquers, alcohols and flammable gases.
Class C Fire			Fires that involve energized electrical equipment where the electrical non-conductivity of the extinguishing media is required.
Class D Fire		N/A	Fires in combustible metals, such as magnesium, titanium, zirconium, sodium, lithium and potassium.

The classification of portable fire extinguishers normally consists of a letter that indicates the class of fire on which the extinguisher has been found to be effective, followed by a rating number (on Class A and Class B only) that indicates the relative extinguishing effectiveness. Fire extinguishers classified for use on Class C or Class D hazards are normally not required to have a rating number.

Modern portable fire extinguishers typically use a picture labeling system to designate the type of fire for which the extinguisher is suitable. See Figure 3-11 for examples.

Instructions are typically provided on the fire extinguisher label or with permanently installed fire suppression systems. It is important that site personnel be familiar with the location and type of extinguishers available at the site. The example in Figure 3-12 uses the acronym “PASS” to describe the following actions typically performed with a handheld fire extinguisher:

1. Pull the pin. Hold the extinguisher with the nozzle pointing away from you and release the locking mechanism.
2. Aim low. Point the extinguisher at the base of the fire.
3. Squeeze the lever slowly and evenly.
4. Sweep the nozzle from side-to-side.

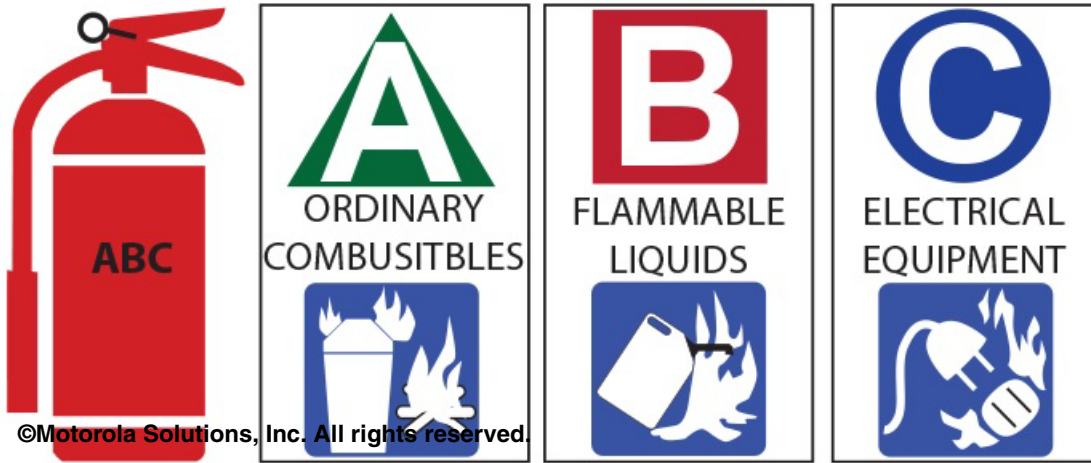

Figure 3-11 Fire Classification Labeling Examples

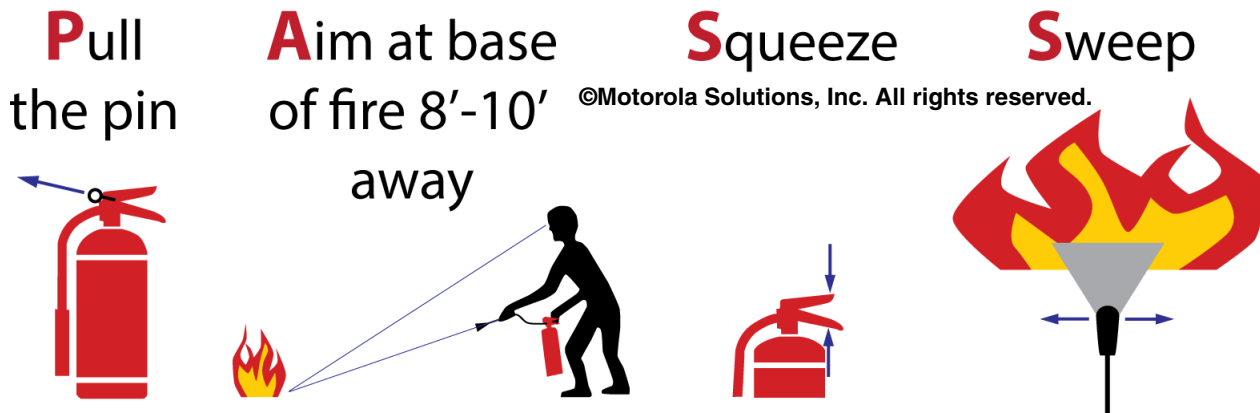

Figure 3-12 Example of Instructions for Fire Extinguisher Use

3.12.4 Portable Extinguishers



The Fire Department **SHALL** be notified as soon as a fire is discovered.



Fixed or portable fire suppression systems using water **shall not** be used in communication sites.

**IMPORTANT**

Portable fire extinguishers shall be inspected as required by the manufacturer and the Authority Having Jurisdiction.

3.12.4.1 Minimum Required Fire Extinguishers

**IMPORTANT**

Local codes shall determine minimum required fire extinguishers, in addition to the requirements listed in this section.

**IMPORTANT**

The presence of an Automatic Suppression System does not negate the need for portable fire extinguishers.

All communications facilities **shall** have a correctly installed portable fire extinguisher on the premises before equipment is installed at the site. At a minimum, building code typically requires a Class ABC portable fire extinguisher with a UL/ULC rating of 2-A:10-B:C for general fire fighting purposes.

An FE-36™ or CO₂ (or equivalent agent) Class BC fire extinguisher with a minimum UL/ULC rating of 10-B:C **shall** be correctly installed in electronic equipment rooms/areas for equipment fire fighting purposes. These extinguisher types minimize secondary damage caused by dry chemical agents used in most Class ABC rated extinguishers.

**CAUTION**

Dry chemical agents contain very fine alkaline-based powders that can cause severe equipment damage due to corrosion. The potential for damage is not just limited to the involved equipment, but may affect all other electronic equipment in the enclosure.

**IMPORTANT**

Dry chemical extinguishers can obscure visibility in a closed room, making egress difficult. A dry chemical type extinguisher should only be considered as a second line of defense if the fire cannot be extinguished with an equipment-friendly Class BC type portable fire extinguisher.

**NOTE**

If an FE-36™ or equivalent clean-agent type portable fire extinguisher is sized to meet Class ABC requirements, a second Class BC portable fire extinguisher is not required.

The following minimum size, classification and UL/ULC rating of portable fire extinguishers **shall** be available at the facility or within the room/area where communications equipment is installed:

- 9 kg (20 lb.), Class ABC, UL/ULC rating 2-A:10-B:C
- 3.2-4.5 kg (7-10 lb.), Class BC, UL/ULC rating 5-B:C

**NOTE**

Review the requirements of NFPA 10 or applicable jurisdictional/ local regulations to determine the need for additional extinguishers based on site size and special considerations. Depending on the size of the site building, additional extinguishers may be required.

3.12.4.2 Required Standards for Portable Fire Extinguishers

Portable fire extinguishers **shall** be listed and labeled, **shall** meet or exceed all the requirements of the fire test standards, and **shall** meet the appropriate performance standards listed in this section.

- Fire Test Standards: ANSI/UL 711, CAN/ULC-S508-M90
- Performance Standards:
 - Carbon Dioxide Types: ANSI/UL 154, CAN/ULC-S503-M90
 - Dry Chemical Types: ANSI/UL 299, CAN/ULC-S504-M86
 - Halocarbon Clean Agent Types: ANSI/UL 2129, CAN/ULC S566

3.12.4.3 Fire Extinguisher Comparisons

Some of the more common extinguishers currently used at communication sites are listed in Table 3-3. The advantages and disadvantages of each type are also described.

Table 3-3 PORTABLE FIRE EXTINGUISHER COMPARISONS

Type	Advantages	Disadvantages
Dry Chemical Extinguishers		
Dry Chemical	<ul style="list-style-type: none"> • Fast flame knockdown characteristics allow the dry chemical to find its way in and around nearly everything in the vicinity of the discharge. • Normally have an ABC rating and are safe for use on structural, fuel and energized electronic equipment fires. • No adverse environmental impact. 	<ul style="list-style-type: none"> • Dry chemical agents have corrosive characteristics that can be harmful to electronic equipment and other equipment in the general area. • A dry chemical fire extinguisher containing ammonium compounds shall not be used on oxidizers that contain chlorine. The reaction between the oxidizer and the ammonium salts can produce an explosive compound. • When discharged in an enclosed or confined space, dry chemical extinguishers limit visibility, cause breathing problems and clog air filtration systems. • Cleanup can be time consuming and costly.
Clean Agent Extinguishers		
FE-36™ (HFC-236fa)	<ul style="list-style-type: none"> • Environmentally friendly replacement of Halon™ 1211 portable extinguishers. • Depending on size, the extinguishing unit can be rated for an ABC classification and discharged from up to 4.9 m (16 ft) away from fire. • Agent is dispersed as a stream of gas and liquid droplets that physically removes heat and chemically stops combustion. • Electrically nonconductive, residue-free, will not cause thermal shock damage to equipment. • Zero ozone depletion potential and moderate ratings for the global warming potential and atmospheric lifetime. 	<ul style="list-style-type: none"> • May not be readily attainable or easily refilled in certain areas. • Typically much more costly to purchase and maintain than dry chemical extinguishers. • When released under fire conditions, hydrofluoric acid (HF) can be produced.
Carbon Dioxide (CO ₂)	<ul style="list-style-type: none"> • Uses a clean gaseous extinguishing agent, with proven reliability. • Normally available in BC classification. Can be used on electronic equipment safely without leaving any residue. • No special environmental impact. • Normally easy to obtain. Inexpensive recharge. 	<ul style="list-style-type: none"> • Effective range limited, typically between 0.92 to 2.4 m (3 to 8 ft), and is affected by draft and wind. Initial application needs to start reasonably close to fire. • Usage displaces oxygen, posing a suffocation hazard in confined areas. • Upon coming in contact with moisture, carbon dioxide can form carbonic acid.

3.12.4.4 Fire Extinguisher Installation

When installing fire extinguishers, the following requirements **shall** be observed:

- Portable fire extinguishers **shall** be maintained in a fully charged and operable condition and **shall** be stored in their designated places at all times when they are not being used.
- Fire extinguishers **shall** be conspicuously located where they are readily accessible and immediately available in the event of a fire. Preferably, extinguishers **shall** be located along normal paths of travel, including exits from areas.
- Fire extinguisher locations **shall** be clearly marked. Acceptable means of identifying the fire extinguisher locations include arrows, lights, signs or coding of the wall or column.
- If more than one fire extinguisher is located in the same location and they are intended for different classes of fires, the intended use of each extinguisher **shall** be marked conspicuously to aid in the choice of the proper extinguisher at the time of a fire.
- Cabinets housing fire extinguishers **shall not** be locked.
- Fire extinguishers **shall not** be obstructed from view.
- Portable fire extinguishers (other than wheeled types) **shall** be securely installed in the hanger or in the bracket supplied or placed in cabinets or wall recesses. The hanger or bracket **shall** be securely and properly anchored to the mounting surface in accordance with the manufacturer's instructions.
- Fire extinguishers installed under conditions where they are subject to dislodgment **shall** be installed in brackets specifically designed to retain the extinguisher.
- Fire extinguishers having a gross weight not exceeding 18.14 kg (40 lb.) **shall** be installed so the top of the fire extinguisher is not more than 1.53 m (5 ft) above the floor. Fire extinguishers having a gross weight greater than 18.14 kg (40 lb.) (excluding wheeled types) **shall** be so installed that the top of the fire extinguisher is not more than 1.07 m (3.5 ft) above the floor. In no case **shall** the clearance between the bottom of the fire extinguisher and the floor be less than 102 mm (4 in.).
- Extinguisher operating instructions **shall** be located on the front of the extinguisher and be clearly visible. Hazardous materials identification systems (HMIS) labels, six-year maintenance labels, hydrotest labels or other labels **shall not** be located or placed on the front of the extinguisher.
- Fire extinguisher mounted in cabinets or wall recesses **shall** be placed so that the fire extinguisher operating instructions face outward. The location of such extinguishers **shall** be conspicuously marked.



IMPORTANT

Portable Fire Extinguishers shall be installed according to the Authority Having Jurisdiction.

3.12.5 Fixed Fire Detection, Alarm and Suppression Systems



CAUTION

Fixed or portable fire suppression systems using water **shall not** be used in communication sites.

This section specifies minimum requirements for fire detection, alarm and suppression systems. For additional requirements, see NFPA 12, NFPA 2001, and any other applicable national, state, jurisdictional and local code requirements that may apply. Specifically, fixed systems comprise the following:

- Detection systems
- Alarm systems
- Automatic suppression systems

Any work involving installation of these systems **shall** be performed only by certified personnel skilled in this work (typically a contractor specializing in these systems). This section is provided to aid personnel charged with purchasing, inspecting, testing, approving, operating and maintaining this equipment in their consultations with an appropriate, contracted fire protection engineering firm.

Some communications equipment systems include detectors and alarms that transmit to centralized control centers within the system itself. High-rise buildings often utilize a second dedicated facility alarm and can be included as part of a central alarm system connected to the local fire department.

3.12.5.1 Automatic Fire Detection

Automatic fire detection **shall** be accomplished by any listed or approved method or device capable of detecting and indicating heat, flame, smoke, combustible vapors or an abnormal condition in the controlled area that is likely to produce fire. On large installations the fire detection system **shall** consist of a combination ionization smoke detector and a rate compensated fixed temperature thermal detector. This type of two-loop detection system will provide a positive verification of a fire condition and the earliest possible pre-alarm notification. The detector units **shall** conform to UL 268 standards (or equivalent requirements for the site area). If the fire detection system is the type that shuts off power to the installation, battery operated emergency light sources **shall** be provided in the affected areas.

3.12.5.2 Automatic Alarms

Automatic alarms or indicators (or both) indicate the operation of the system, hazards to occupants or failure of any supervised device. The type (audible or visual), number and location of these devices **shall** be such that their purpose is satisfactorily accomplished. As a minimum, the fire alarm system **shall** give an initial warning signal for evacuation of occupants and for confirmation of a fire condition. A secondary alarm system **shall** sound, indicating the automatic discharge of a fire-extinguishing agent. The system **shall** have a time delay function between the two warning signals which can be adjusted to provide adequate time for evacuation or abort procedures.

3.12.5.3 Site Alarm Switch Form

Site alarms are defined as any action, reaction or determinations associated with diagnostics, security or emergency. All equipment providing alarms will send alarms from the equipment utilizing dry-contact closures. The dry contact closures will conform to Form-C configuration, providing Common, Normally-Open and Normally-Closed contacts. The outputs will not be referenced to either ground or any voltage potential.

3.12.5.4 Automatic Suppression Systems

Automatic suppression systems automatically discharge fire-extinguishing agents when a fire condition is detected. With use of control panels, directional valves and flow control equipment, these systems can be used to protect against one or more hazards or groups of hazards. Where two or more hazards (for example, A-class fire or B-class fire) may be simultaneously involved in the fire by reason of proximity, both hazards **shall** be protected with separate individual systems and the combination arranged to operate simultaneously. The other option is that they could be protected with a single system that **shall** be sized and arranged to simultaneously discharge on all potentially involved hazards that have indicated an alarm condition. A qualified fire protection engineer **shall** be consulted when designing automatic extinguishing systems.

If an overhead sprinkler system is used, the “dry pipe” type **shall** be used. Upon detection of a fire condition, this type of system removes source power to the room and then opens a master valve to fill the overhead sprinklers. These systems sometimes use a primary suppressor such as CO₂, releasing before the sprinkler system is activated. Dry pipe systems can have enough of a delay so that a manual reset can be provided, if allowable. This system is preferable to a “wet” type system, which has the chance of water leakage and resultant equipment damage and can possibly use rancid water that has been stored in overhead pipes for long periods.

If power connections are made beneath raised floors, waterproof electrical receptacles and connections **shall** be used in all types of installations.



IMPORTANT

The presence of an automatic fire suppression system does not negate the need for portable fire extinguishers.

Figure 3-13 shows an example of an automatic fire suppression system.

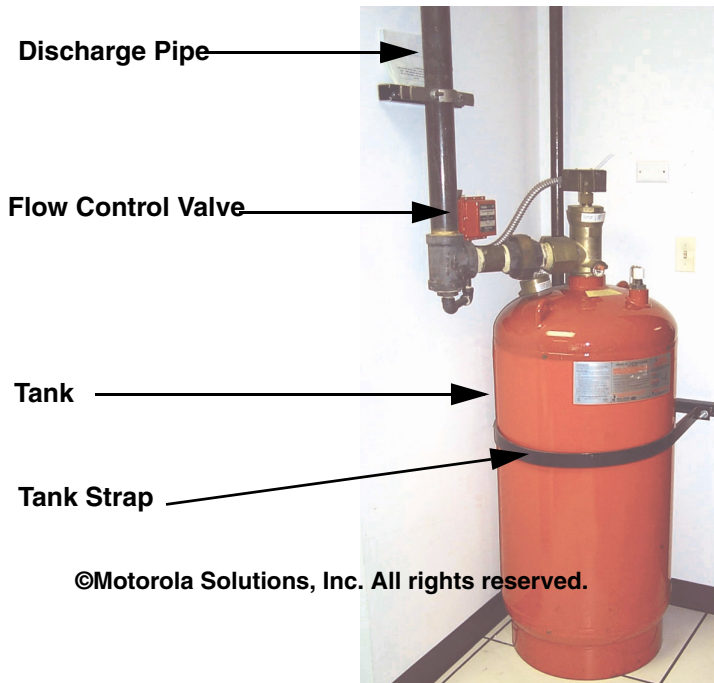

Figure 3-13 Example of Automatic Suppression System

3.12.6 Warning Signs

Appropriate warning signs **shall** be affixed outside of areas where concentrations of extinguishing gases can accumulate. This should not be limited to just protected spaces but in the adjacent areas where the gases could migrate or leak (such as the storage room for the gas containers, adjacent rooms and hallways). There **shall** be a warning sign posted at the entrance to the protected area and inside the protected space. See Figure 3-14 for an example.



Figure 3-14 Example of Warning Signs

3.12.7 Power Sources

The primary power source for the fire extinguishing system's operation and control **shall** have the capacity for intended service and **shall** be reliable. Where failure of the primary power source would jeopardize the protection provided, a secondary (standby) power source **shall** supply energy to operate the system for a period of 24 hours and be capable of operating the extinguishing system continuously for the full designed discharged period. The secondary (standby) power **shall** automatically transfer to operate the system within 30 seconds of the loss of primary power.

3.12.8 Fixed Systems Comparison

If a new system is being installed or an existing fixed fire-extinguishing system is being replaced, always check with local fire prevention authorities and a competent fire protection engineer first. Be ready to supply information about the material composition of the building or housing structure, occupancy of the structure, environment and equipment that needs to be protected. Ask for their recommendations on the type of extinguishing systems needed, along with any advantages and disadvantages of a particular system.

Some of the more common fixed systems currently used at communication sites are listed in Table 3-4. The advantages and disadvantages of each type are also described.

Table 3-4 FIRE SUPPRESSION SYSTEMS

Type	Advantages	Disadvantages
Water Extinguishing (Water Sprinkler)	<ul style="list-style-type: none"> Upon detection of a fire condition, a “dry pipe” type of system removes source power to the room and then opens a master valve to fill the overhead sprinklers. (The “dry pipe” system is preferable to a “wet pipe” system, which has the chance of water leakage and resultant equipment damage and possible electrical shock.) No adverse environmental impact. 	<ul style="list-style-type: none"> If power connections are made beneath raised floors, waterproof electrical receptacles and connections are required. Either type of water sprinkler system could cause electronic equipment damage and will require an extensive cleanup effort. Upon discharge, system downtime can be lengthy.
Clean Agent Extinguishing System		
FE-13™ (HFC-23)	<ul style="list-style-type: none"> Environmentally friendly replacement of Halon™ 1301-based systems. Advantage over CO₂ systems, due to FE-13 lack of oxygen displacement characteristic. Electrically nonconductive and residue-free. No cleanup is required after discharge and system downtime can be kept to a minimum. The storage cylinder(s) may be stored away from the protected area. Storage cylinders can be stored in a wide range of temperatures; containers need not be stored in protected places at room temperature. System recharge is less expensive than alternative fluorocarbon agents. 	<ul style="list-style-type: none"> May not be readily attainable or easily refilled in certain areas. Typically much more costly to purchase and maintain than water systems. When released under fire conditions hydrofluoric acid (HF) can be produced.
FM-200™ (HFC-227ea)	<ul style="list-style-type: none"> Environmentally friendly replacement of Halon 1301-based systems. Less toxic than Halon 1301. Electrically nonconductive and residue-free; no cleanup is required after discharge. System downtime can be kept to a minimum. When compared with Halon 1301, FM200 systems require minimal additional floor storage space. 	<ul style="list-style-type: none"> System recharge can be more expensive than other types of extinguishing agents. When released under fire conditions hydrofluoric acid (HF) can be produced.

Table 3-4 FIRE SUPPRESSION SYSTEMS (CONTINUED)

Type	Advantages	Disadvantages
INERGEN™ (IG-541)	<ul style="list-style-type: none"> • Environmentally friendly replacement of Halon 1301-based systems. It has no Ozone Depleting Potential, Global Warming Potential or Atmospheric Lifetime. • No toxic or corrosive decomposition products. • Electrically nonconductive and residue-free; no cleanup is required after discharge. System downtime can be kept to a minimum. • Because INERGEN is stored as a gas, it can be stored at a substantial distance from the risk area, where more space is available. 	When compared with Halon 1301 and FM200 systems, INERGEN systems require more cylinders and additional floor storage space.

3.13 Safety Equipment

The following safety equipment **shall** be permanently located inside all equipment shelters and in or within close proximity to tenant improvement equipment rooms:

- First aid kits
- Eye wash station
- Battery safety equipment including personal protection equipment in any area with wet cell batteries
- Construction/installation safety equipment
- Safety markings and barriers



NOTE

It is strongly recommended that all employees obtain formal training and certification in First Aid and cardiopulmonary resuscitation (CPR).

3.13.1 First Aid Kit

- Because many communications facilities are located in areas far from medical help, a first aid kit **shall** be present at every site.
- All first aid kits, case and contents **shall** meet or exceed the specifications of ANSI Standard Z308.1.
- All first aid kits **shall** be mounted in a conspicuous, easily-accessible location.
- The first aid kit case **shall** be durable and rustproof and **shall** allow for wall mounting.

3.13.2 Typical Battery Safety Kit

Depending on the type of batteries used, a safety kit may be required within the battery area.

Where required by OSHA or applicable jurisdictional or local codes, the following equipment **shall** be supplied:

- A lightweight, acid resistant bib type apron **shall** be permanently stored on site near the battery plant. The fabric **shall** be acid, caustic, puncture resistant and flame resistant.
- An acid resistant, full face shield, **shall** be permanently stored on site near the battery plant. The shield **shall** meet all requirements of ANSI Z87.1. Protective eye wear that does not provide full face protection **shall not** be allowed.
- One pair of acid resistant gloves **shall** be permanently stored on site near the battery plant. These gloves **shall** be of sufficient length to cover the hand, wrist and forearm for protection from chemical splash.

- One 0.5 kg (1 lb.) box of baking soda or equivalent acid neutralizing compound **shall** be permanently stored on site near the battery plant.
- Water **shall** be provided to mix with the baking soda.
- An OSHA-approved emergency eyewash station **shall** be permanently mounted near the battery plant. The eyewash station **shall** use an isotonic saline wash capable of neutralizing acids or caustics and **shall** be able to flush the eye for 15 minutes. A plumbed eyewash station and a shower should be provided in battery areas if practicable.

Figure 3-15 shows examples of a battery safety kit.



Figure 3-15 Examples of Battery Safety Kit



IMPORTANT

Discard and replace bottled eyewash solution according to the expiration date on the bottle. Only appropriate eyewash solution shall be used.

3.14 On Site Communications

Some form of two-way communications **shall** be available at each facility, for safety reasons as well as for performing maintenance and troubleshooting. Many outages occur after hours and normally only one technician is dispatched to perform repairs. Cellular phones may only be used if there is known coverage at the location.

- Important numbers **shall** be posted on or near the entrance door such as but not limited to:
 - Police, ambulance and fire personnel
 - Site owner
- For maintenance and troubleshooting, a telephone or microwave orderwire is invaluable, if monitored. In most cases the technician must contact a central support group and/or a computer in order to obtain help. Many new systems require a communications link to download the operational information in order for the equipment to function.
- Note that neither a mobile radio in a maintenance vehicle nor a personal portable radio should routinely be used for onsite communications requirements.
- On-site communication between personnel on the ground and any personnel working on a tower **shall** be maintained at all times.

3.15 Signage

An equipment room entrance door, roof entrance door, shelter, enclosure, tower or site compound **shall** be posted with signs identifying the site and providing notices and warnings. The types of site signage **shall** be in accordance with national, state and jurisdictional/local regulations.

Signs containing general required notices, along with spaces for custom information, are commercially available and should be used. Warning signs containing the appropriate information and symbols are also commercially available and should be used.

3.15.1 Minimum Required Signage

At a minimum, sites which are not continuously supervised **shall** post the following:

- **Authorized Personnel Only - No Trespassing**

Mandatory legal requirements exist in which signage must be conspicuously posted to warn against unauthorized access to the site. Appropriate signage **shall** be posted during all phases of site planning, construction and operation. See Figure 3-16 for an example.

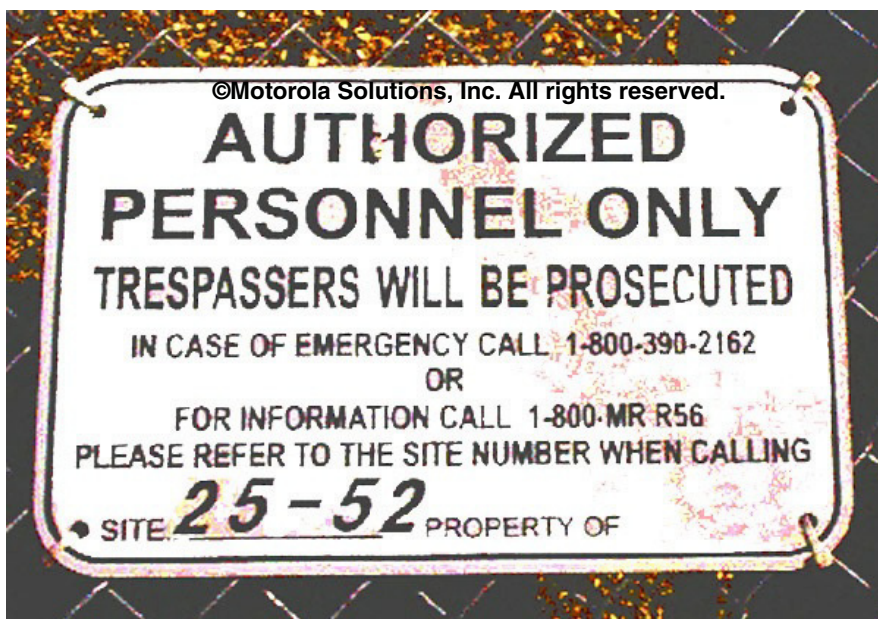

Figure 3-16 Example of “No Trespassing” Sign

- **Responsible Entity Identification**

- The site **shall** have conspicuous signage identifying the site operating entity and providing appropriate contact information. See Figure 3-17 for an example.
- Permit or licensing information (as assigned by the Federal Communications Commission or other equivalent) **shall** also be included.

- **Battery Area Signage**



WARNING

NFPA signs advising the Fire Department of battery electrolyte reactivity with water SHALL be posted (see Figure 3-18).

- Appropriate signage **shall** be present on doors leading to battery rooms and within the room itself, notifying personnel of explosion, chemical and electrical hazards within the area. See Figure 3-18 for an example of such signage.
- “NO SMOKING” signs **shall** be prominently displayed in the battery room and on the exterior of the battery room entry door. Smoking and any other spark-producing materials or activities **shall** be strictly prohibited in this area.



Figure 3-17 Typical Entity Identification Sign

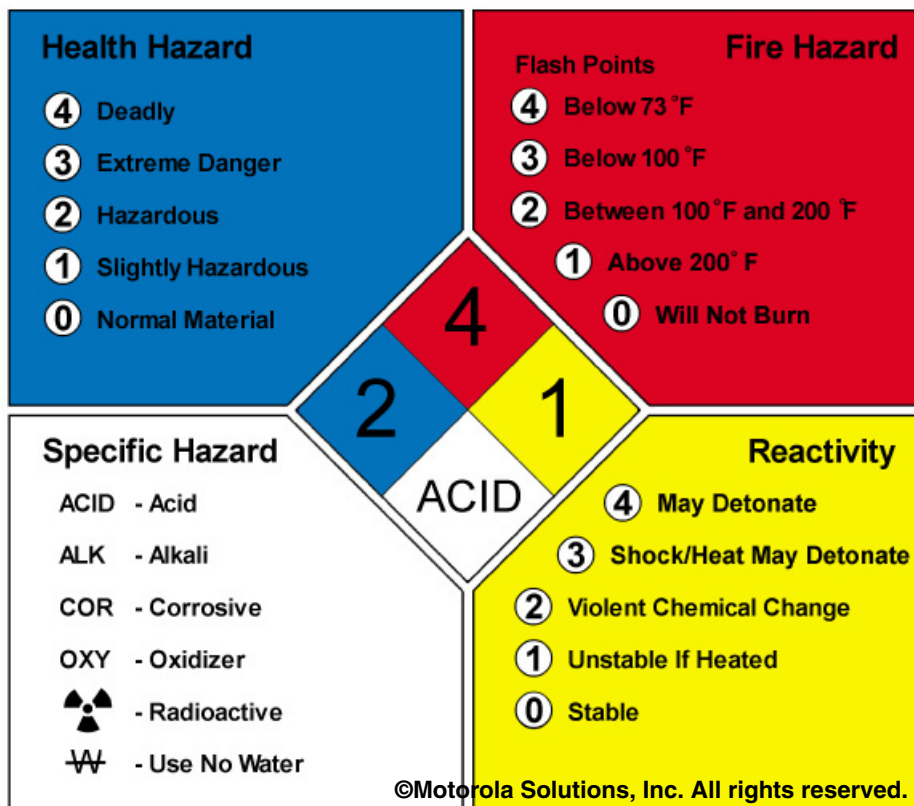

Figure 3-18 Example of Warning Signage for Specific Hazards

3.15.2 Additional Signage

- Depending on the site's function, additional signage may be required. These signs typically notify of potential hazards associated with authorized or unauthorized site entry.
- Engineering personnel designing the site **shall** be aware of conditions that may be present at the site that could warrant warning signage. Such conditions are, but are not limited to, high voltage and RF energy emissions hazards. See Figure 3-19 for an example of an RF notice.
- See Appendix A, “Electromagnetic Energy (EME) Information”, for additional information regarding EME signage.



Figure 3-19 Typical RF Warning Sign

THIS PAGE INTENTIONALLY LEFT BLANK.

External Grounding (Earthing) and Bonding

This chapter provides requirements and guidelines for designing and installing the external grounding (earthing) and bonding system at a communications site. The requirements and guidelines in this chapter are provided to enhance personnel safety and equipment reliability.

This chapter provides information on the following topics:

- “Lightning Activity and Exposure” on page 4-3
- “Site Type Classification: Definitions” on page 4-5
- “Common Grounding” on page 4-6
- “Grounding System Component and Installation Requirements” on page 4-7
- “Grounding (Earthing), Bonding and Down-Conductors” on page 4-37
- “Dissimilar Metals and Corrosion Control” on page 4-52
- “Bonding to the External Grounding and Bonding System” on page 4-57
- “Minimum Site Grounding (Earthing) Requirements” on page 4-74
- “Bonding of RF Preamplifiers and Other Active Devices on Tower” on page 4-95
- “Grounding Roof-Mounted Antenna Masts and Metal Support Structures” on page 4-114
- “Grounding (Earthing) Rooftop Mounted Tower Structures” on page 4-119
- “Special Grounding (Earthing) and Bonding Applications” on page 4-122
- “Special Situations” on page 4-134



NOTE

Throughout this chapter the terms “grounding” and “earthing” are used interchangeably.



NOTE

NFPA 70 is also known as the *National Electrical Code*® or *NEC*®. NFPA 780 is the *Standard for the Installation of Lightning Protection Systems*.

4.1 Introduction to External Grounding (Earthing) and Bonding

Grounding is defined as connecting to ground (the earth) or to a conductive body that extends the ground connection (NFPA 70-2017, Article 100). Bonding is defined as connecting to establish electrical continuity and conductivity (NFPA 70-2017, Article 100).

Safety of personnel and protection of sensitive electronic equipment from ground faults, lightning, ground potential rise, electrical surges and power quality anomalies is of utmost importance at any communications site. Though unexpected electrical events like lightning strikes and power surges cannot be prevented, this chapter provides design and installation information on communications site grounding and bonding that may help minimize damage caused by these events.

The requirements and guidelines in this chapter are derived from a compilation of local and national codes, widely accepted industry codes and standards and good engineering practices. Such codes and standards are from, but not limited to, the following standards organizations:

- Alliance for Telecommunications Industry Solutions (ATIS)

- American National Standards Institute (ANSI)
- Australian Standards® (AS)
- British Standards Institution (BSi)
- International Association of Electrical Inspectors (IAEI)
- International Electrotechnical Commission (IEC)
- International Telecommunication Union (ITU)
- Institute of Electrical and Electronics Engineers (IEEE)
- National Fire Protection Association (NFPA)
- Telecommunications Industry Association (TIA)
- Underwriters Laboratories (UL)
- United States Department of Defense (DoD)
- United States Federal Aviation Administration (FAA)
- United States National Weather Service (NWS)

References to specific industry codes and standards are provided throughout the chapter.

**CAUTION**

Grounding and bonding alone are not enough to adequately protect a communications site. Transient Voltage Surge Suppression (TVSS) techniques, using appropriate Surge Protective Devices (SPD), **shall** be incorporated at a communications site in order to provide an adequate level of protection. See Chapter 7, “Surge Protective Devices,” for details and requirements.

A grounding electrode system **shall** have low electrical impedance, with conductors large enough to withstand high fault currents. The lower the grounding electrode system impedance, the more effectively the grounding electrode system can dissipate high-energy impulses into the earth.

**WARNING**

The AC power system ground SHALL be sized appropriately for the electrical service and SHALL be approved by the Authority Having Jurisdiction (AHJ).

All site development and equipment installation work **shall** comply with all applicable codes in use by the Authority Having Jurisdiction (AHJ). Grounding systems **shall** be installed in a neat and workmanlike manner (ATIS-0600313.2013, section 11.1; ATIS-0600334.2013, section 13.1; IEC 60364-1:2005, section 134; NFPA 70-2017, Article 110.12; and NFPA 780-2017, section 1.5.1). Where conflicting, the more stringent requirement **shall** be followed.

**IMPORTANT**

Local codes and other codes enforced by the AHJ shall take precedence over the requirements of this manual. The more stringent requirement shall be followed.

Unusual site conditions may require additional effort to achieve an effectively bonded and grounded site. See “Special Situations” on page 4-134 in these instances. Consultation with Motorola Solutions Engineering or an engineering firm specializing in grounding electrode system design is recommended.

Some of the benefits of a properly designed and installed low-impedance grounding electrode system are described as follows (see ATIS-0600333.2013, section 4; ATIS-0600334.2013, section 5.1; BS 7430:2011; IEC 60364-1:2005; IEEE 142-2007, section 1.3; IEEE 1100-2005, section 3.3.1; ITU *Earthing and Bonding Handbook*, section 2.1.2; and NFPA 70-2017, Article 250.4, for additional information):

- To help limit the voltages caused by lightning.
- To provide a path to earth for the discharge of lightning strokes in a manner that protects the structure, its occupants and the equipment inside.
- To help limit the voltage caused by accidental contact of the site AC supply conductors with conductors of higher voltage.
- To help dissipate electrical surges and faults, to minimize the chances of injury from grounding system potential differences.
- To help maintain a low potential difference between exposed metallic objects.
- To stabilize the AC voltage relative to the earth under normal conditions.
- To contribute to reliable equipment operation.
- To decrease noise in signal and control circuits by minimizing the voltage differentials between different signal reference subsystems.
- To provide a common signal reference ground.

4.2 Lightning Activity and Exposure

Communications facilities **shall** be defined as exposed to lightning unless the ground flash density is an average of 0.3 flashes/km²/year or fewer **and** earth resistivity at the site is less than 100 ohm-meters (Ω -m). The soil resistivity **shall** be measured as described in ANSI/IEEE 81 (ATIS-0600313.2013, section 5.1.1). See Appendix B, “Soil Resistivity Measurements”, for soil resistivity measurement methods.

Figure 4-1 and Figure 4-2 are maps representing typical lightning activity throughout the world. These figures are for general informational and educational purposes only and are not indicative of current or future lightning activity. The average amount of lightning that occurs in any given area varies significantly from year to year.



WARNING

Personnel SHALL NOT work on a tower or in the equipment building during an electrical storm (IEEE 1692-2011, section 12).



NOTE

In this manual, high-lightning areas are areas with lightning flash density greater than two (2) flashes/km²/year.



NOTE

Refer to NFPA 780-2017, Annex M, for information on personal safety from lightning.

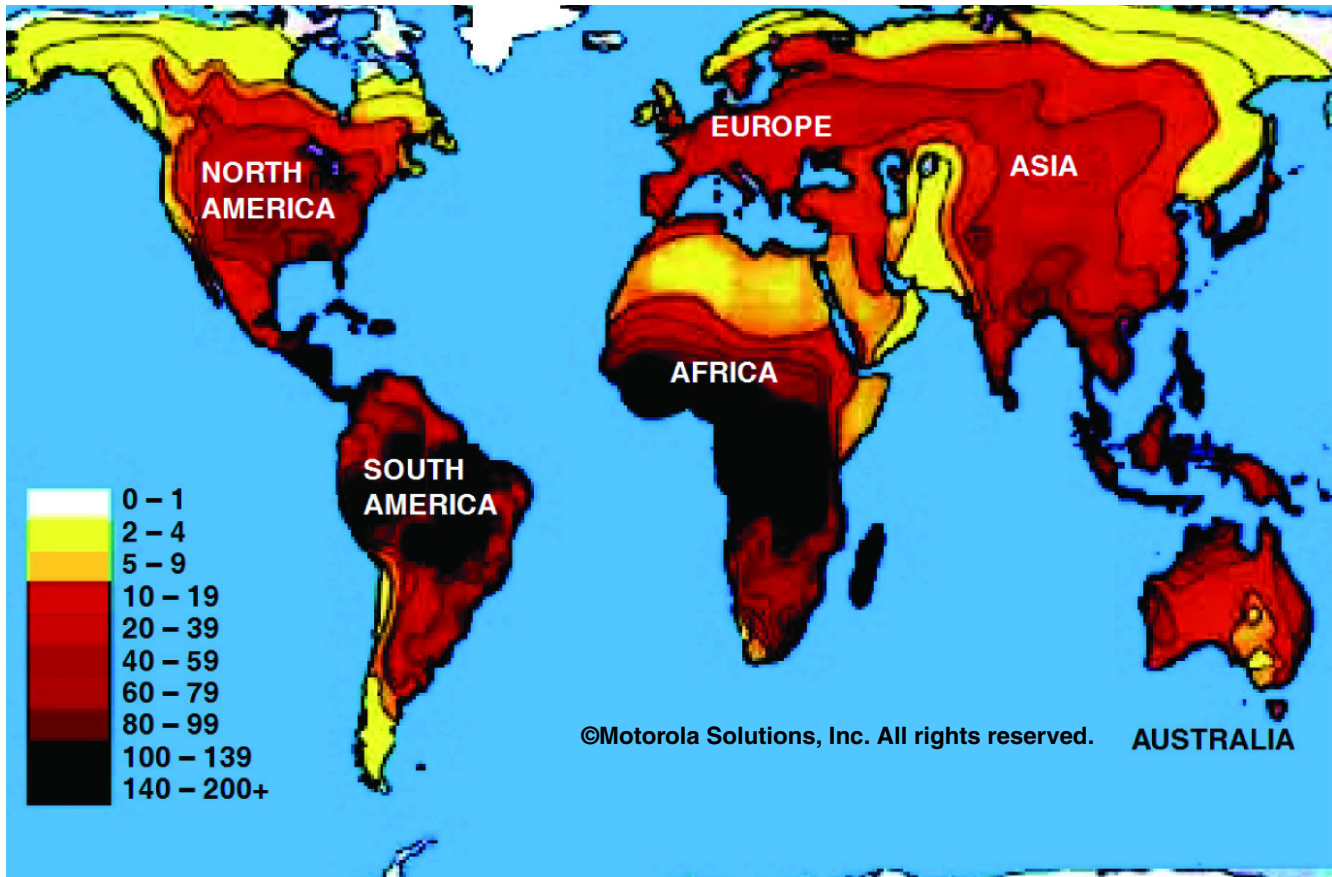

Figure 4-1 Lightning Activity, Thunderstorm Days Per Year

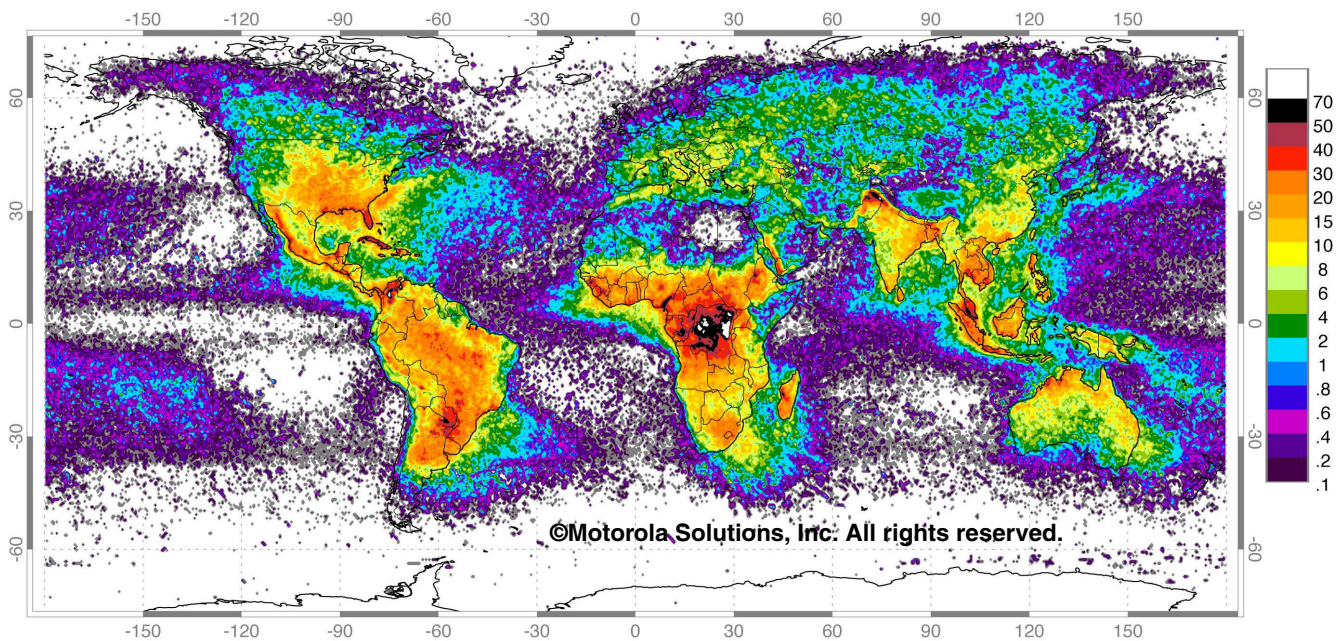

Figure 4-2 Lightning Activity, Flash Density (Flashes per Square Kilometer per Year)

Table 4-1 provides a relationship between thunderstorm days per year and lightning flashes per square kilometer per year.

Table 4-1 RELATIONSHIP BETWEEN THUNDERSTORM DAYS PER YEAR AND LIGHTNING FLASHES PER SQUARE KILOMETER PER YEAR

Thunderstorm days per year	Flashes per square kilometer per year		Flashes per square mile per year	
	Mean	Limits	Mean	Limits
5	0.2	0.1 to 0.5	0.5	0.25 to 1.35
10	0.5	0.15 to 1	1.29	0.38 to 2.59
20	1.1	0.3 to 3	2.84	0.77 to 7.77
30	1.9	0.6 to 5	4.92	1.55 to 13
40	2.8	0.8 to 8	7.25	2 to 20.7
50	3.7	1.2 to 10	9.58	3.1 to 25.9
60	4.7	1.8 to 12	12.17	4.66 to 31
80	6.9	3 to 17	17.87	7.8 to 44
100	9.2	4 to 20	23.82	10.36 to 51.8

Source: BS 6651:1999, Table 6.

Communications facilities located at elevations significantly higher than the average elevation of the surrounding terrain (such as hilltops, fire towers, airport control towers and high-rise buildings) **shall** be considered exposed to lightning regardless of thunderstorm activity and earth resistivity (ATIS-0600313.2013, section 5.1.1).

Communications facilities with a tower **shall** be considered as exposed, regardless of thunderstorm activity and soil resistivity. By their very construction, radio antennas/towers are considered exposed to the possible damaging effects of lightning. Tall structures such as towers, buildings and antenna masts, provide a favorable discharge point for lightning strokes. (ATIS-0600313.2013, section 5.2.3)

Some communications facilities may be classified as unexposed if the building and tower are within the zone of protection of a higher structure. Only a qualified engineer should determine if the communications facility is not exposed. Standards that can be used by the engineer to help determine communications facility lightning exposure include BS/EN 62305-3, IEC 62305-3 and NFPA 780-2017.

4.3 Site Type Classification: Definitions

Communications sites vary and may serve different purposes; therefore the level of protection required also varies. Communications sites are classified into three general categories according to their function and level of required protection. The site classifications are *Light Duty* (Type A), *Standard Duty* (Type B) and *Extra Duty* (Type B2). Light Duty sites do not require the same extensive grounding electrode system as Standard Duty or Extra Duty sites, nor do Light Duty sites require as low a value of grounding electrode system resistance as Standard Duty or Extra Duty sites. See TIA-607-C, section C.2.3, for more information.

The general site characteristics are listed in the following section.

4.3.1 Light Duty (Type A)

Light Duty sites have the following general characteristics:

- The site is not considered exposed to lightning. See “Lightning Activity and Exposure” on page 4-3.
- No tower is associated with the site
- Single control station or remote control
- Single voting receiver site
- Point-to-Point/Multi-point radio
- Wireless Access Points
- Electronic equipment installed at the site does not require an extensive grounding electrode system

See “Type “A” Site: Light Duty” on page 4-75 for more information.

4.3.2 Standard Duty (Type B)

If any of the following apply, the site should be considered a *Standard Duty* site:

- The site is considered exposed to lightning. See “Lightning Activity and Exposure” on page 4-3.
- A tower is associated with the site
- The site houses public safety or *mission critical* installations
- The site is a 911 or other communications dispatch center (without a co-located tower)
- The site is a large system installation

See “Type “B” Sites: Standard Duty” on page 4-77 for more information.

4.3.3 Extra Duty (Type B2)

Extra Duty sites typically fall into two general categories:

- Sites that are normally occupied and have a co-located tower. Examples: communications dispatch centers or 911 emergency dispatch centers.
- Sites that have a co-located tower and contain electronic equipment necessary for the operation of other wide-area communications sites. A failure at this type of site typically results in performance degradation or loss of communications at other sites. This type of site may be referred to as a *Master* or *Prime* site.

Extra Duty sites have the following general characteristics:

- Communications dispatch center with a co-located tower
- 911 emergency dispatch center with a co-located tower
- Master site with a co-located tower
- Prime site with a co-located tower

See “Type “B” Sites: Standard Duty” on page 4-77 for more information.

4.4 Common Grounding

At a communications site, all grounding (earthing) electrodes **shall** be bonded together to form a single grounding electrode system. All grounding electrodes used for grounding of the power system, grounding of communications systems and grounding of lightning protection systems **shall** be effectively and permanently bonded together (IEEE 1100-2005, section 8.5). The AC power system ground, communications tower ground, lightning protection system ground, telephone system ground, exposed structural building steel (metal frame/framework), underground metallic piping that enters the facility and any other existing grounding electrode system **shall** be bonded together to form a single grounding electrode system (ATIS-0600313.2013, section 7; ATIS-0600333.2013, section 5.1; ATIS-0600334.2013, section 5.3; IEC 62305-3, section 6.2; ITU *Earthing and Bonding Handbook*, section 3.1; IEEE 1100-2005; IEEE 1692-2011; NFPA 70-2017, Articles 250.58, 250.104, 250.106, 800.100, 810.21, 820.100 and 830.100; and NFPA 780-2017, section 4.14).

Underground metallic piping systems typically include water service, well castings located within 7.6 m (25 ft) of the structure, gas piping, underground conduits, underground liquefied petroleum gas piping systems and so on. Interconnection to a gas line **shall** be made on the customer's side of the meter (IEC 60364-5-54:2011, section 542.2.6; and Annex B; NFPA 780-2017, section 4.14.6.7).

See Figure 4-3 for a common grounding example.

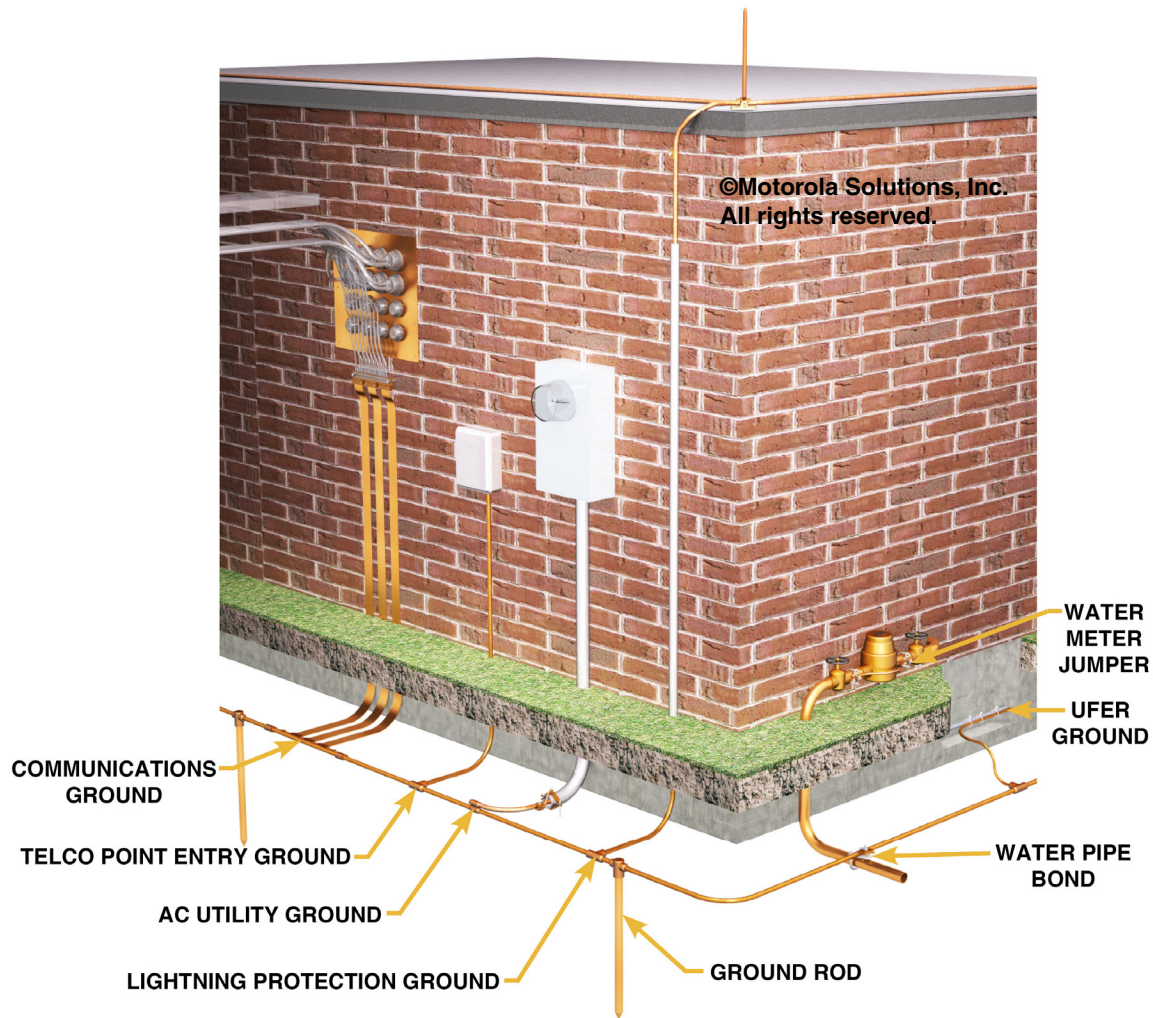

Figure 4-3 Common Grounding Example – All Grounding Electrodes Bonded Together



WARNING

Failure to interconnect all grounding electrode systems at a communications site can result in hazardous potential differences, which may lead to injury to personnel and/or equipment failure.

4.5 Grounding System Component and Installation Requirements

The external grounding and bonding system may consist of, but is not limited to, the components shown in Figure 4-4.

©Motorola Solutions, Inc. All rights reserved.

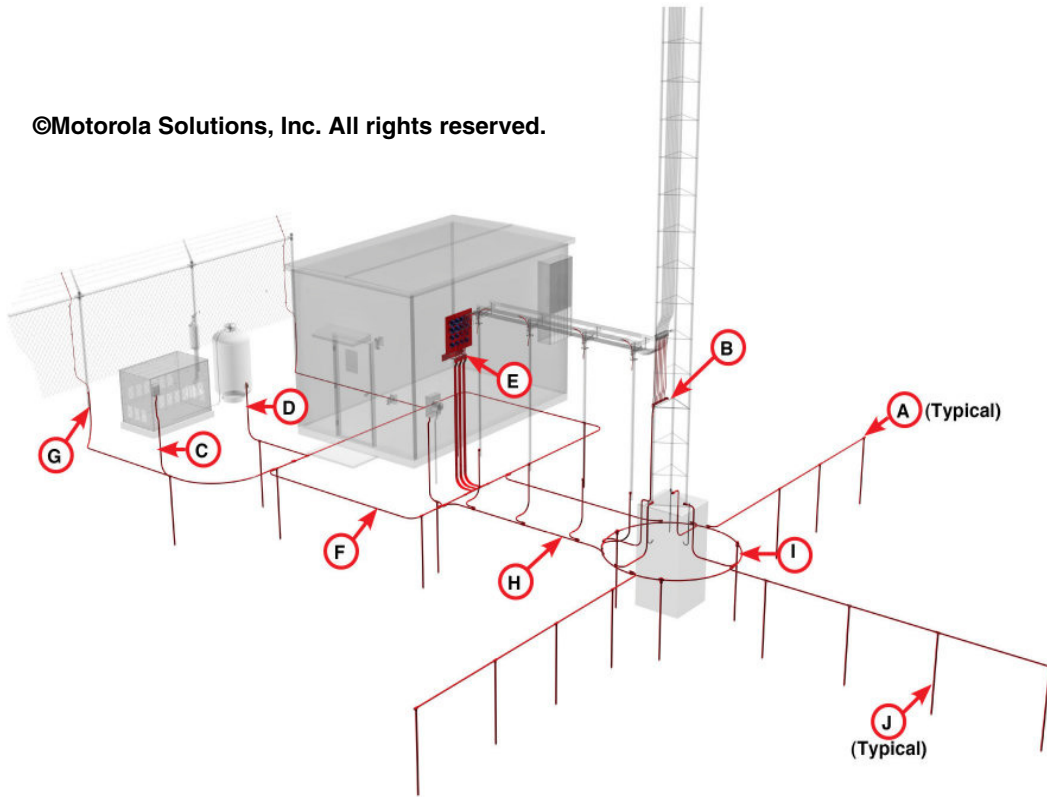

A:	Grounding Radials
B:	Tower Ground Bus Bar and Down Conductors
C:	Generator Grounding Conductor
D:	Fuel Tank Grounding Conductor
E:	External Ground Bus Bar
F:	Shelter Ground Ring
G:	Fence Grounding Conductor
H:	Ground Ring Bonding Conductor (2 minimum)
I:	Tower Ground Ring
J:	Earthing Electrodes (Ground Rods)

Figure 4-4 Typical External Grounding Electrode System



To prevent accidental damage to underground utilities, always have the local utility company or utility locator service locate the underground utilities before excavating or digging at a site.

4.5.1 Grounding (Earthing) Electrodes

Grounding electrodes are the conducting elements used to connect electrical systems and/or equipment to the earth. The grounding electrodes are placed into the earth to maintain electrical equipment at earth potential. Grounding electrodes may consist of ground rods, metal plates, concrete-encased electrodes, ground rings, electrolytic ground rods, wire mesh, the metal frame of building or structure, metal underground water pipes and other listed electrodes (NFPA 70-2017, Article 250 (III)).

**IMPORTANT**

Metallic underground gas piping shall not be used as a grounding electrode (IEC 60364-5-54:2011, section 542.2.6, and NFPA 70-2017, Article 250.52), but shall be bonded to the grounding electrode system upstream from the equipment shutoff valve (IEC 60364-5-54:2011, section 542.2.6 and Annex B; NFPA 70-2017, Article 250.104; and NFPA 780-2017, section 4.14.6.7).

**IMPORTANT**

Aluminum electrodes are not permitted (NFPA 70-2017, Article 250.52, and NFPA 780-2017, section 4.2.2.3.1). Also see IEC 62305-3:2010, section 5.5.1.

**NOTE**

Water pipes are not permitted to be used as earth electrodes in several European countries. See IEC 60364-5-54:2011, section 542.2, for additional information.

4.5.1.1 Ground Rod Resistance Characteristics and Sphere of Influence

Around a grounding electrode, such as a driven ground rod, the resistance of the soil is the sum of the series resistances of virtual concentric shells of earth, located progressively outward from the rod. The shell nearest the ground rod has the smallest circumferential area or cross section, so it has the highest resistance. Successive outward shells have progressively larger areas and therefore progressively lower resistances (see IEEE 142-2007, section 4.1.2, and MIL-HDBK-419A).

The effect of the concentric shells is that a finite amount of earth is required in order for a ground rod to fully realize its resistance value. This finite amount of earth is commonly known as the ground rod's sphere of influence. **The sphere of influence for a ground rod is commonly thought to be a radius around the ground rod equal to its length.** A ground rod achieves approximately 94% of its resistance value at this radius; 100% is achieved at a radius of approximately 2.5 times the rod length. See IEEE 142-2007, section 4.1, and Figure 4-5.

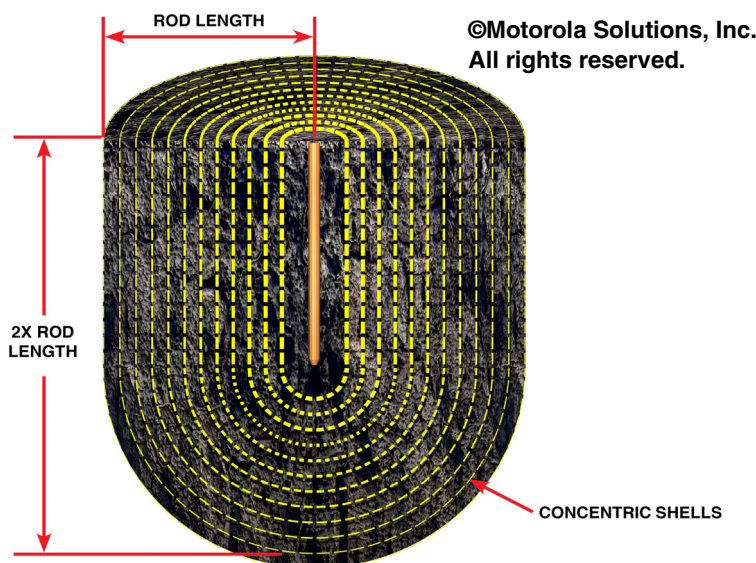

Figure 4-5 Ground Rod Sphere of Influence

As shown in Figure 4-6, maximum efficiency of parallel ground rods is achieved where the respective spheres of influence do not overlap.

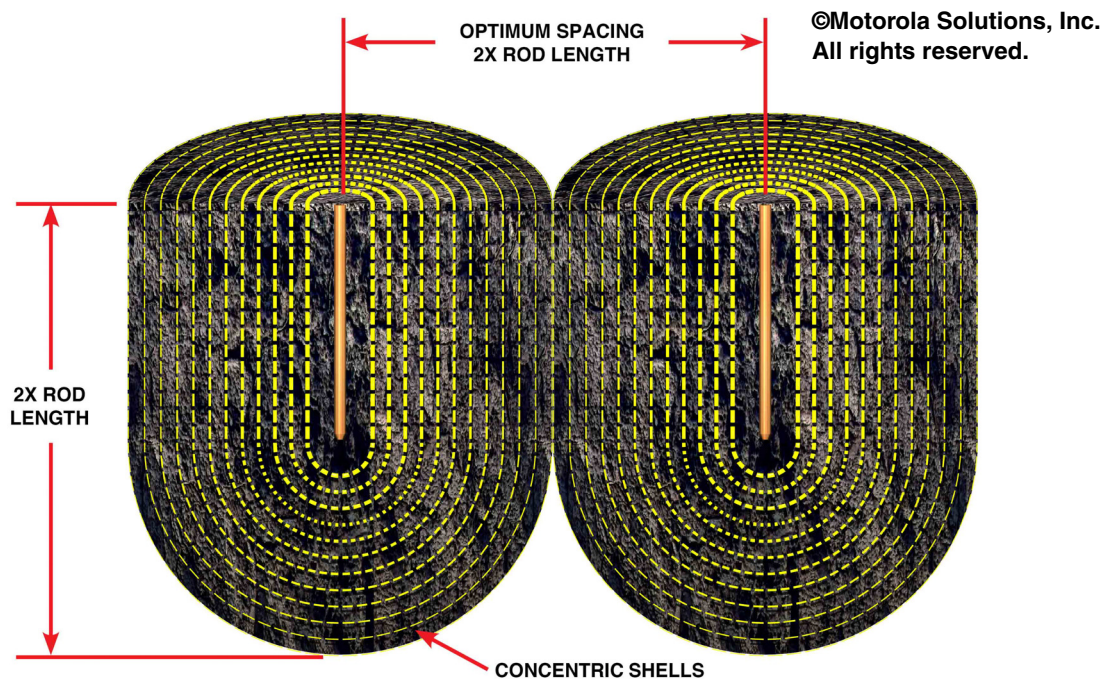

Figure 4-6 Ground Rod Spacing for Maximum Efficiency

Table 4-2 provides the relationship between percentage of total ground rod resistance and the radial distance from the ground rod (IEEE 142-2007, Table 4-1).

Table 4-2 TOTAL GROUND ROD RESISTANCE VS. DISTANCE FROM GROUND ROD

Distance from Electrode Surface (r)**		Approximate Percentage of Total Resistance
ft	Meters	
0.1	0.03	25%
0.2	0.06	38%
0.3	0.09	46%
0.5	0.15	52%
1.0	0.3	68%
5.0	1.5	86%
10.0*	3.0*	94%*
15.0	4.6	97%
20.0	6.1	99%

Table 4-2 TOTAL GROUND ROD RESISTANCE VS. DISTANCE FROM GROUND ROD

Distance from Electrode Surface (r)**		Approximate Percentage of Total Resistance
ft	Meters	
25.0	7.6	100%
<p>* 94% of the resistance to remote earth occurs within a radius equal to the length of the ground rod. This radius is commonly used as the ground rod's sphere of influence.</p> <p>** Ground rod resistance at a radius (r) from a 3 m × 16 mm (10 ft × 0.625 in.) ground rod (From IEEE 142-2007, Table 4-1)</p>		

Table 4-2 (IEEE 142-2007, chapter 4) indicates the following:

- Within the first 2.5 cm (1 in.) from the ground rod, 25% of the total resistance to earth is achieved.
- Within the first 152 mm (6 in.) from the ground rod, 52% of the total resistance to earth is achieved.
- The area immediately around a ground rod is the most important for reducing its resistance to earth. See “Grounding (Earthing) Electrode Encasement Materials” on page 4-35 for information on reducing resistance.
 - In high resistivity soil areas, decreasing the soil resistance in this area is useful in improving the effectiveness of the grounding electrode system. This can be achieved using a ground rod or electrolytic ground rod encased in a grounding electrode encasement material.
 - In porous soil areas, decreasing the contact resistance with the ground rod in this area is useful in improving the effectiveness of the grounding electrode system. This can be achieved using a ground rod or electrolytic ground rod encased in a grounding electrode encasement material.



NOTE

In a given area, more ground rods installed closer together (such as one length apart from one another) achieves a lower resistance to earth than fewer rods installed farther apart (such as twice the length apart from one another). For example, five 3 m (10 ft) ground rods installed 6.1 m (20 ft) apart in a 24.4 m (80 ft) straight line achieves a resistance to earth of 7.8 ohms (assuming 10,000 ohm-cm soil). Nine 3 m (10 ft) ground rods installed 3 m (10 ft) apart in the same 24.4 m (80 ft) straight line achieves a resistance to earth of 5.7 ohms.

The resistance to earth of a ground rod can be calculated using the following formula (IEEE 142-2007, Table 4-5):

$$R = \frac{\rho}{2\pi L} \left[\ln\left(4\frac{L}{a}\right) - 1 \right]$$

Where:

R: The resistance to earth of the ground rod in ohms (Ω)

ρ : The soil resistivity in ohm-centimeters (Ω -cm)

L: The length of the ground rod in centimeters (cm)

a: The ground rod radius in centimeters (cm)

The following tool can also be used to calculate the resistance of a ground rod: [Single Ground Rod Resistance Calculator](#)

4.5.1.2 Ground Rods

Typical ground rods are shown in Figure 4-7. Requirements for ground rods are as follows. See IEEE 142-2007, section 4.3.1, and CSA C22.2 No. 41-07/UL 467-2007 for additional information.

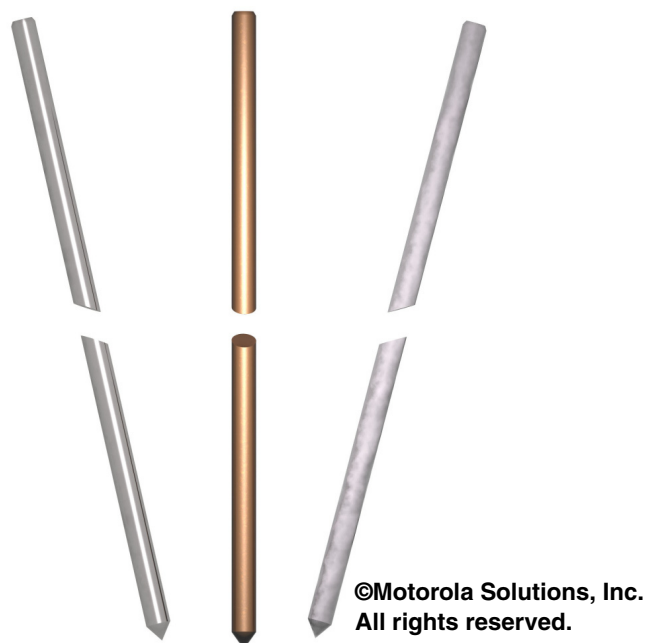

Figure 4-7 Typical Ground Rods

4.5.1.3 Ground Rod Specifications

Ground rods are manufactured in various diameters and lengths. This section contains the general ground rod requirements:

- Ground rods **shall** be listed by a Nationally Recognized Testing Laboratory (NRTL).



IMPORTANT

The type of ground rod installed shall be compatible with soil conditions at the site. See Table 4-9 for more information.



IMPORTANT

Stainless steel ground rods shall be formed of an austenitic stainless steel of the 18 percent chromium, 8 percent nickel type (CSA C22.2 No. 41-07/UL 467-2007, section 6.9).



IMPORTANT

Due to potential corrosive effects, galvanized ground rods should not be installed near concrete-encased electrodes. Copper, copper-clad steel or stainless steel rods should be used to help prevent corrosion (IEC 62305-3:2010, section E.5.6.2.2.2).

- Ground rods **shall** be constructed of copper-clad steel, solid copper, hot-dipped galvanized steel or stainless steel (IEEE 1692-2011, section 8.2; TIA-607-C, section B.2; and ATIS-0600334.2013, section 5.3.2). See NFPA 70-2017, Article 250.52 and CSA C22.2 No. 41-07/UL 467-2007, section 6.9, for additional information.

- Ground rods **shall** have a minimum length as required by local codes and not less than 2.44 m (8 ft) (NFPA 70-2017, Article 250.52; ATIS-0600313.2013, section 10.3.1; ATIS-0600334.2013, section 5.3.2; IEEE 1692-2011, section 8.2; and UL 467-2007). Ground rods with a minimum length of 3 m (10 ft) should be considered (ANSI/TIA-222-G).

**NOTE**

The minimum ground rod length in Canada is 3 m (10 ft) (CSA C22.2 No. 41-07).

- Longer rods, such as 3 m (10 ft), should be considered for areas highly prone to lightning, sites with poor soil resistivity and/or military installations (MIL-HDBK-419A, MIL-STD-188-124B and TIA-607-C, section B.2).
- Ground rods **shall** have a minimum diameter of 15.9 mm (0.625 in.) (NFPA 70-2017, Article 250.52; ATIS-0600313.2013, section 10.3.1; and ATIS-0600334.2013, section 5.3.2; and IEEE 1692, section 8.2), unless otherwise allowed by the listing of the ground rod (see CSA C22.2 No. 41-07/UL 467-2007).
- Ground rods **shall** be free of paint or other nonconductive coatings (NFPA 70-2017, Article 250.53 and NFPA 780-2017, section 4.13.2.2).
- Galvanized ground rods should only be used where soil conditions are not favorable to the use of copper or copper-clad (such as organic acids soil conditions). See Table 4-9 for more information.

4.5.1.4 Ground Rod Installation

This section contains the general ground rod installation requirements:

- Where practicable, ground rods **shall** be buried below permanent moisture level (NFPA 70-2017, Article 250.53 and MIL-HDBK-419A).
- Ground rods should penetrate below the frost line (MIL-HDBK-419A).

**NOTE**

Check with the Authority Having Jurisdiction (AHJ) for frost line depth information.

- Ground rods longer than the minimum required 2.4 m (8 ft) may be required in order to maintain contact with permanently moist, unfrozen soil (MIL-HDBK-419A). See Figure 4-8.

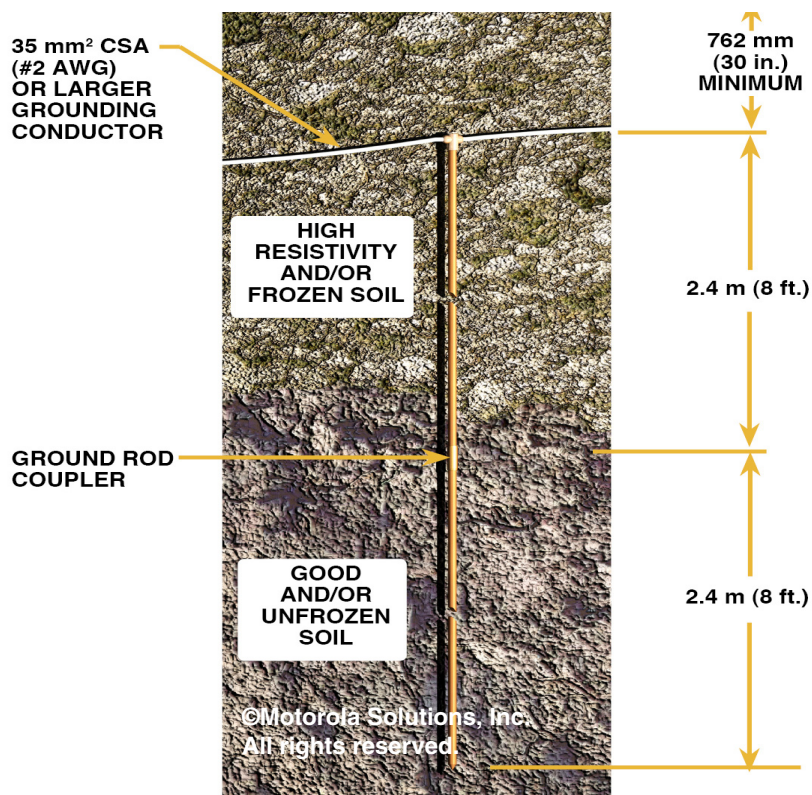

Figure 4-8 Ground Rods Coupled to Penetrate to Suitable Soil

- Ground rods that cannot be driven straight down due to contact with rock formations may be driven at an oblique angle of not greater than 45° from the vertical or may be buried horizontally and perpendicular to the building, in a trench at least 762 mm (30 in.) deep, as shown in Figure 4-9 (NFPA 70-2017, Article 250.53). See Figure 4-19 for an example of horizontal ground rods installed perpendicular to the building and tower.



IMPORTANT

The top of a ground rod shall not be cut off if contact with rocks prevents driving of the rod to the required depth. Alternate driving techniques, as described previously, shall be used in these cases.

- The method of bonding grounding conductors to ground rods **shall** be compatible with the types of metals being bonded. See “Dissimilar Metals and Corrosion Control” on page 4-52.



WARNING

When operating power tools, always wear appropriate safety glasses and other protective gear to help prevent injury.

- Hammer drills or electric jackhammers may be used to drive ground rods. Precautions should be taken to prevent deforming (mushrooming) of the ground rod head (IEEE 142-2007, section 4.3.2).
- If rock formations prevent ground rods from being driven to the specified depth, an alternate method of achieving an acceptable grounding electrode system **shall** be implemented. See “Special Situations” on page 4-134 for additional information.

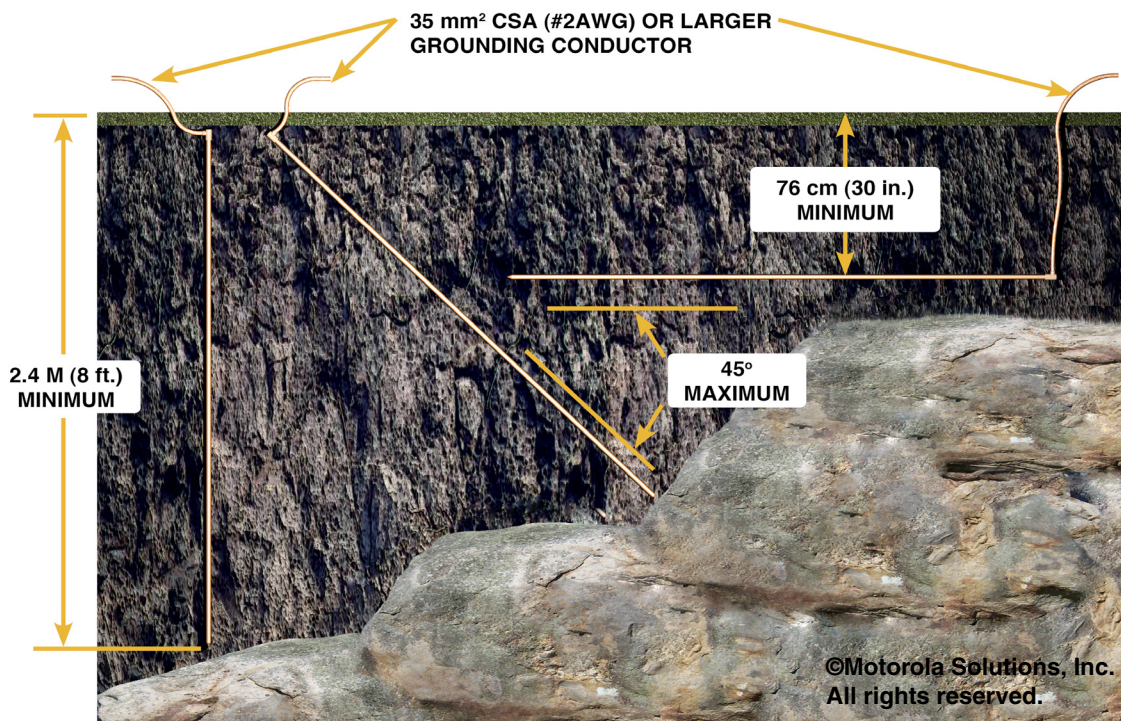

Figure 4-9 Angled Ground Rod Installation

- Where the grounding electrode system design requires longer ground rods in order to lower the grounding electrode system resistance, reach the permanent moisture level or penetrate below the frost line, two or more ground rods may be joined together using a coupler (threaded, compression sleeve or exothermic weld). Threaded rods or compression sleeves **shall** be listed (see IEEE 142-2007, section 4.3.1). See Figure 4-10.



Figure 4-10 Example of Sectional Ground Rod and Ground Rod Coupler

4.5.1.4.1 Light Duty (Type A) Sites



NOTE

At a Light Duty (Type A) site, for better efficiency from each individual ground rod, the ground rods should be installed farther apart than the 1.8 m (6 ft) allowed by NFPA 70-2017, Article 250.53, such as the sum of their respective lengths. See Figure 4-6 for more information.

- Where not part of a ground ring system, such as at a Light Duty (Type A) site, the entire length of the rod **shall** be in contact with soil (NFPA 70-2017, Article 250.53). It is recommended to install the ground rods so the top of the rod is buried to a minimum depth of 610 mm (24 in.) below the surface of the earth (NFPA 780-2017, section 4.13.2.3.1). See Figure 4-11.

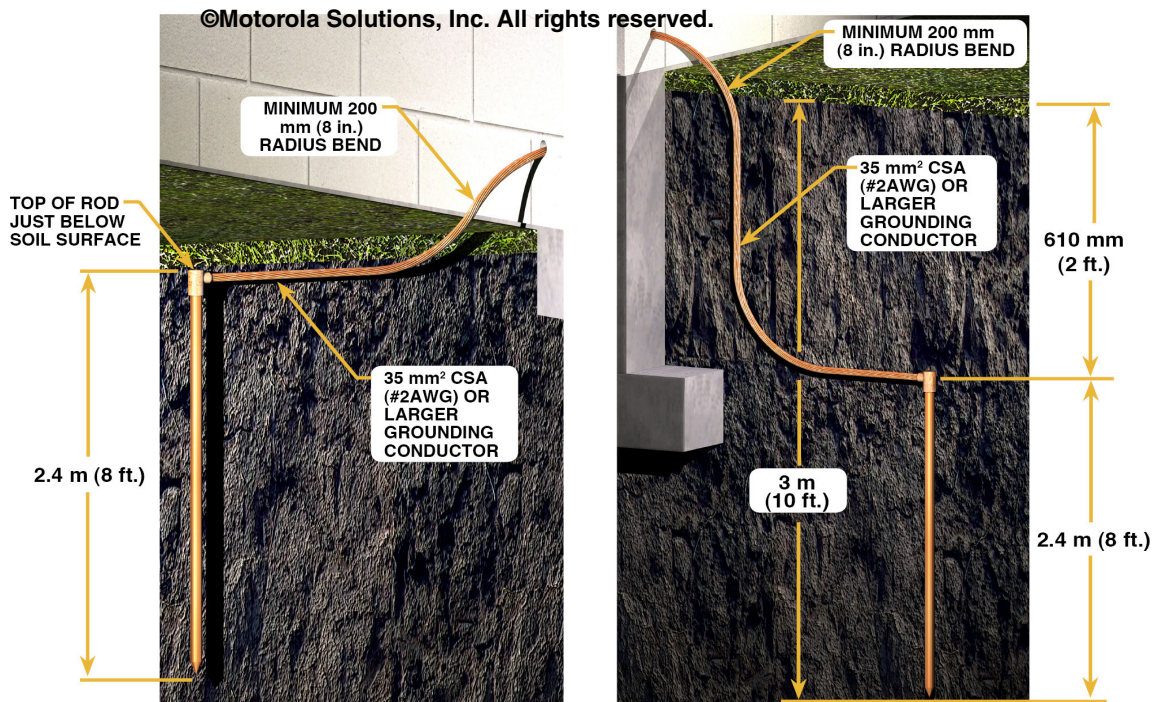

Figure 4-11 Typical Single Ground Rod Installations for Type A Sites

- Ground rods **shall not** be installed closer than 1.8 m (6 ft) to other ground rods and grounding electrodes (NFPA 70-2017, Article 250.53). See Figure 4-12 for an example.



Figure 4-12 Parallel Ground Rod Installation

4.5.1.4.2 Standard Duty (Type B) and Extra Duty (Type B2) Sites:

- Where part of a ground ring system, the top of the ground rods **shall** be buried to the depth of the ground ring, typically 762 mm (30 in.) minimum below finished grade. See “External Building and Tower Ground Ring” on page 4-25.
- Where part of a ground ring system, ground rods **shall** be installed at 3 m to 4.5 m (10 ft to 15 ft) intervals (ATIS-0600334.2013, section 5.3.2).
- See “External Building and Tower Ground Ring” on page 4-25 for additional information.

4.5.1.4.3 Effect of Ground Rod Size on Resistance to Earth

Increasing the diameter of a ground rod does not significantly reduce its resistance to earth. Doubling the diameter of a ground rod reduces its resistance to earth by approximately 10% (see Figure 4-13).

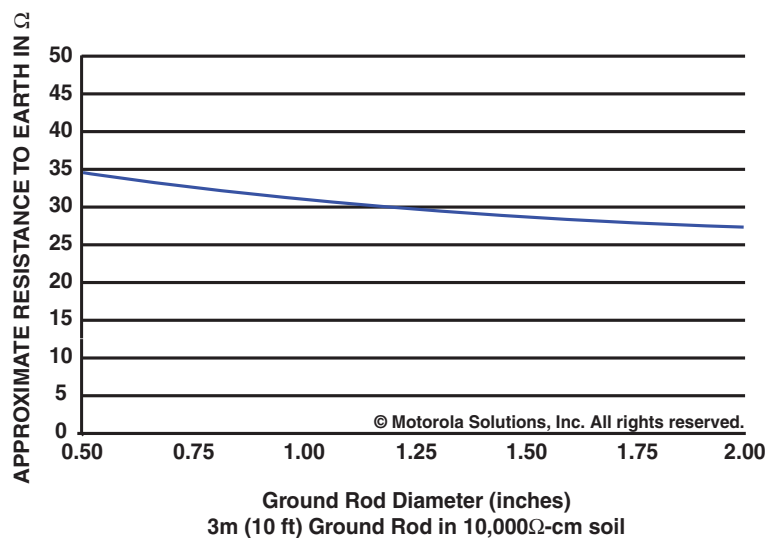

Figure 4-13 Resistance to Earth Due to Ground Rod Diameter

As the length of a ground rod is increased, its resistance to earth is substantially reduced. In general, doubling the length of a ground rod reduces its resistance to earth by approximately 45% (see Figure 4-14).

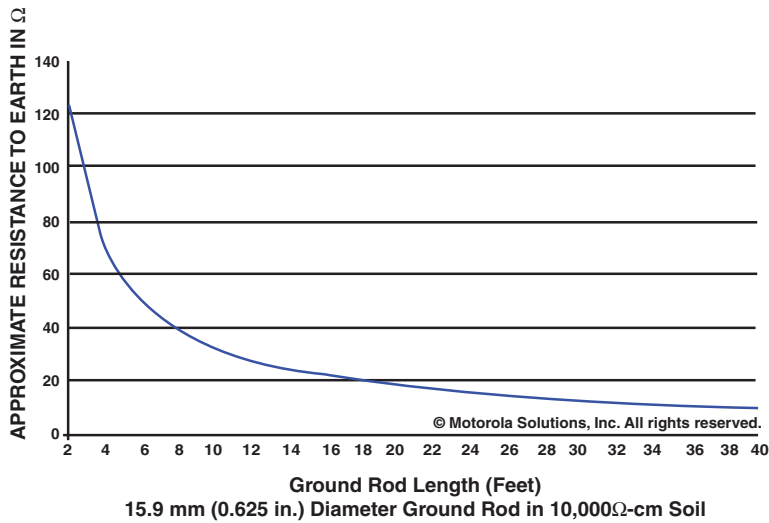

Figure 4-14 Resistance to Earth Due to Ground Rod Length

Figure 4-15 shows the resistance of different length ground rods versus earth resistivity.

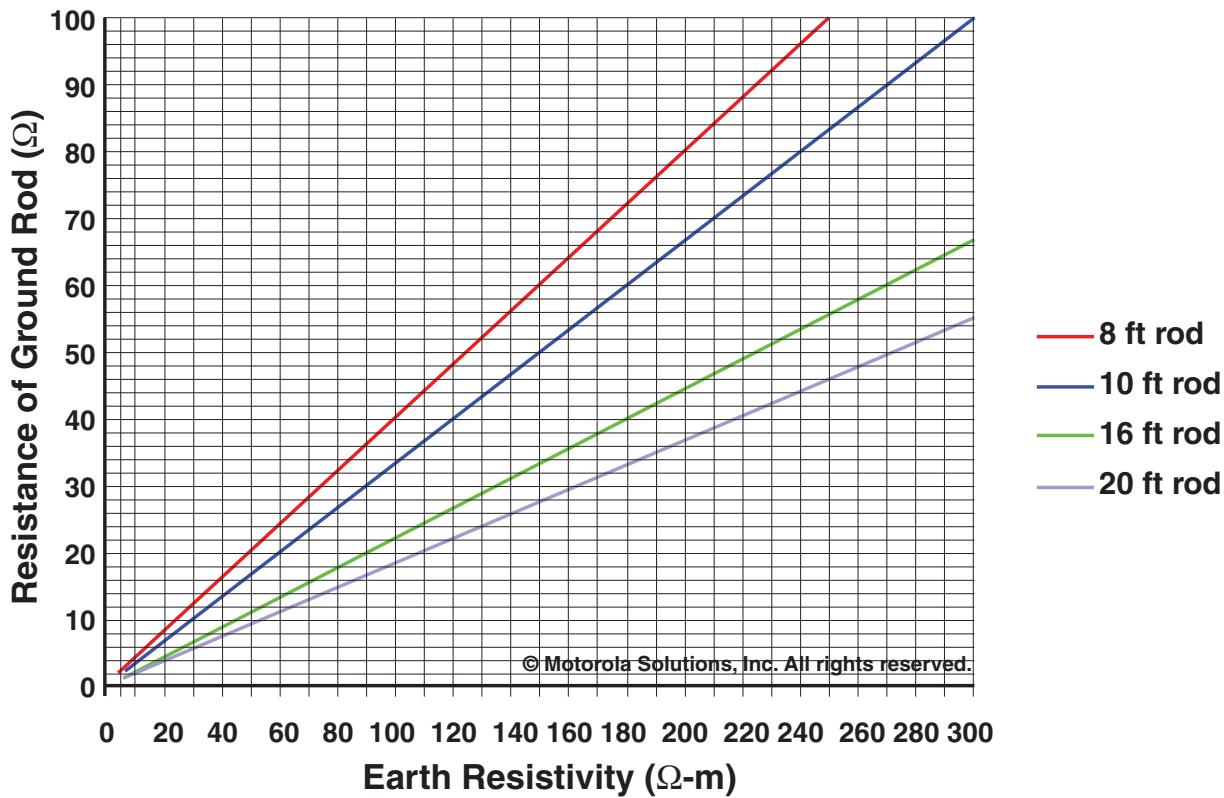

Figure 4-15 Resistance of Ground Rod versus Earth Resistivity

4.5.1.5 Effect of Parallel Ground Rods

Figure 4-16 shows the effects of adding additional ground rods (15.9 mm (0.625 in.) diameter by 3 m (10 ft) long) in parallel. As shown in the figure, the addition of one ground rod to the first ground rod (for a total of two rods) significantly reduces the resistance to earth of the ground rod system. Each subsequent ground rod added in parallel has less of an effect on the resistance to earth of the ground rod system.

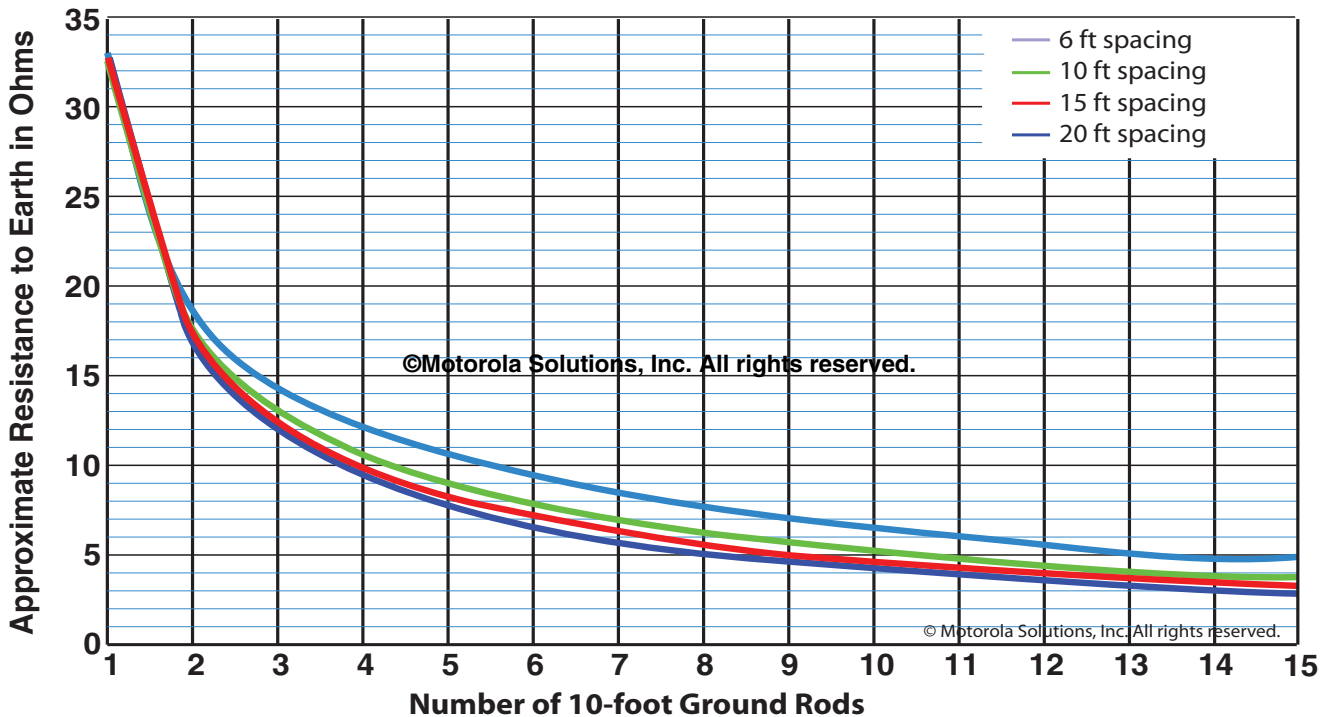

Figure 4-16 Resistance to Earth Due to Parallel Ground Rods

4.5.1.6 Electrolytic Ground Rods

At sites where poor soil conductivity (high resistivity) and/or limited space prevent achievement of acceptable grounding electrode system resistance using standard ground rods, commercially available electrolytic ground rods should be considered (TIA-607-C, section B.3). See MIL-HDBK-419A Volume I, section 2.9.5, and UL 467-2007, section 6.9.3, for additional information. Electrolytic ground rods (Figure 4-17 and Figure 4-18) are available in straight or L-shaped versions and in lengths from 3 m (10 ft) to 6.1 m (20 ft) or longer as a special order. Electrolytic ground rods are generally constructed of 54 mm (2.125 in.) diameter hollow copper or stainless steel pipe filled with a mixture of non-hazardous natural earth salts. Breather holes at the top of the pipe allow the salts to hygroscopically extract moisture from the air, forming conductive electrolytes. These electrolytes then leach out of the pipe into the soil, improving soil conductivity. Electrolytic ground rods are inserted into pre-drilled holes or trenches and then encased in a grounding electrode encasement material. See “Grounding (Earthing) Electrode Encasement Materials” on page 4-35.

Electrolytic ground rods should also be considered for use in grounding electrode systems covered by concrete or pavement, such as parking lots (see “Grounding (Earthing) Electrode Systems Covered by Concrete or Asphalt” on page 4-132). By allowing moisture to enter, the design of the electrolytic ground rod improves the resistance of the grounding electrode system.

Electrolytic ground rods may provide significant improvement over standard ground rods of the same length. The resistance to earth of electrolytic ground rods is generally more stable in environments with variations in temperature and moisture.



IMPORTANT

Only grounding electrode encasement material shall be placed into pre-drilled holes when backfilling around electrolytic ground rods.

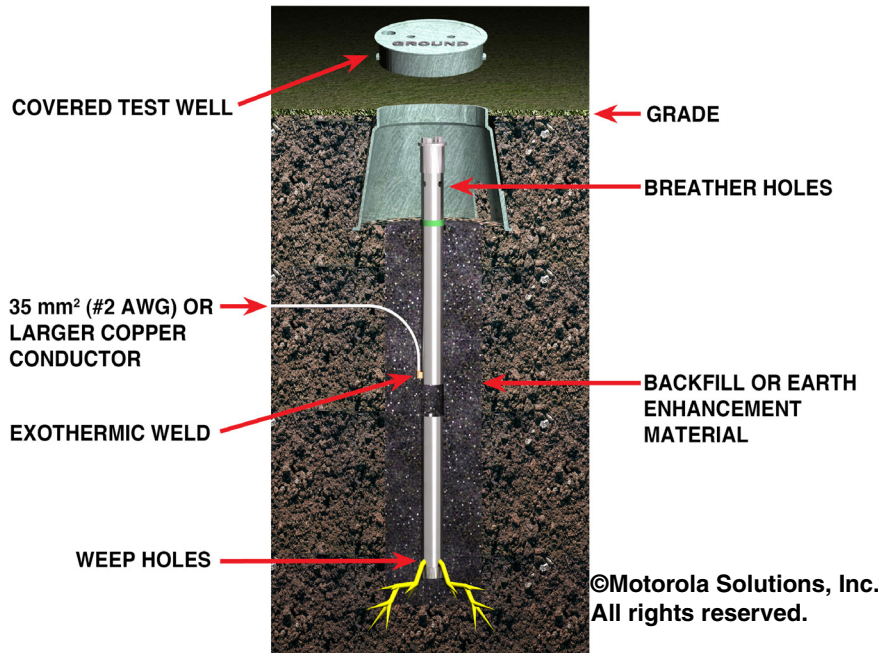

Figure 4-17 Electrolytic Ground Rod: Straight

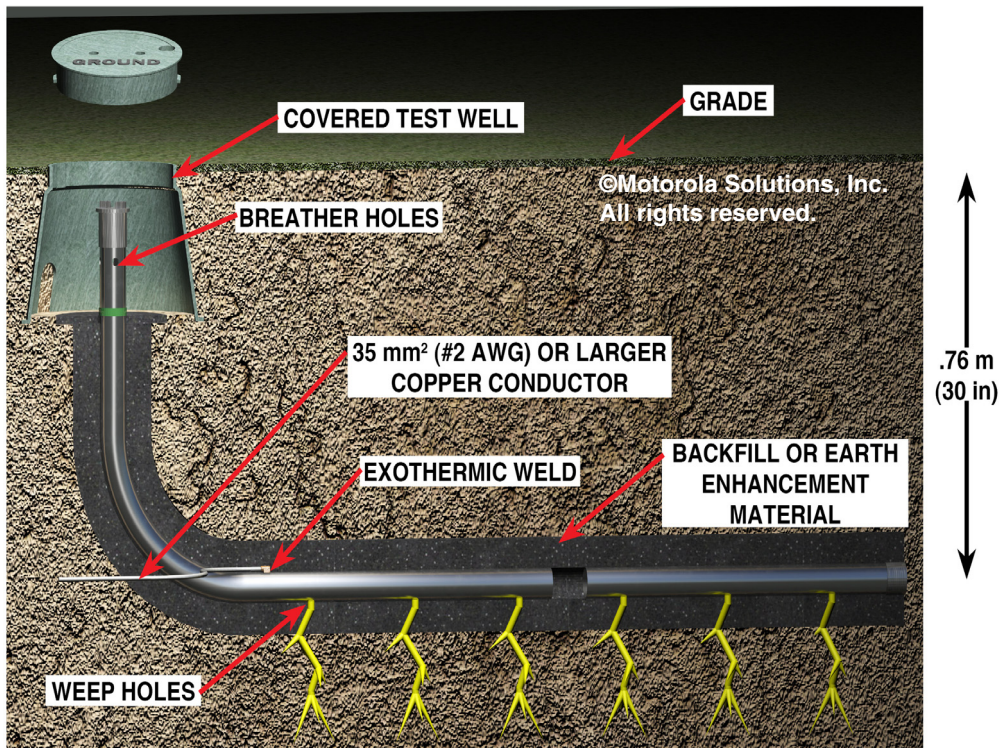

Figure 4-18 Electrolytic Ground Rod: L-Shaped



NOTE

Unless prohibited by local environmental authorities, condensation from the site's HVAC system may be routed to the ground rod area to keep the soil moist, thereby improving soil conductivity.

Requirements for the use of electrolytic ground rods are as follows:

- Electrolytic rods **shall** be listed by a Nationally Recognized Testing Laboratory (NRTL).
- Electrolytic rods **shall** be installed per the manufacturers' recommendation.
- Grounding electrode encasement materials (also known as backfill) **shall** be environmentally safe and approved by the Authority Having Jurisdiction. See “Grounding (Earthing) Electrode Encasement Materials” on page 4-35.
- Grounding electrode encasement materials **shall** be approved by the ground rod manufacturer and **shall** be installed according to supplied instructions. Only grounding electrode encasement material **shall** be used as backfill.
- Electrolytic rods **shall** be free of paint or other nonconductive coatings (NFPA 70-2017, Article 250.53; and NFPA 780-2017, section 4.13.2.2).
- L-shaped electrolytic rods **shall** be installed perpendicular (or as near perpendicular as practicable) to the building, shelter or tower in order to maximize the grounding electrode system surface area. The rod **shall not** be installed in the same trench as the ground ring or grounding conductors. See Figure 4-19 for an example of a typical installation.

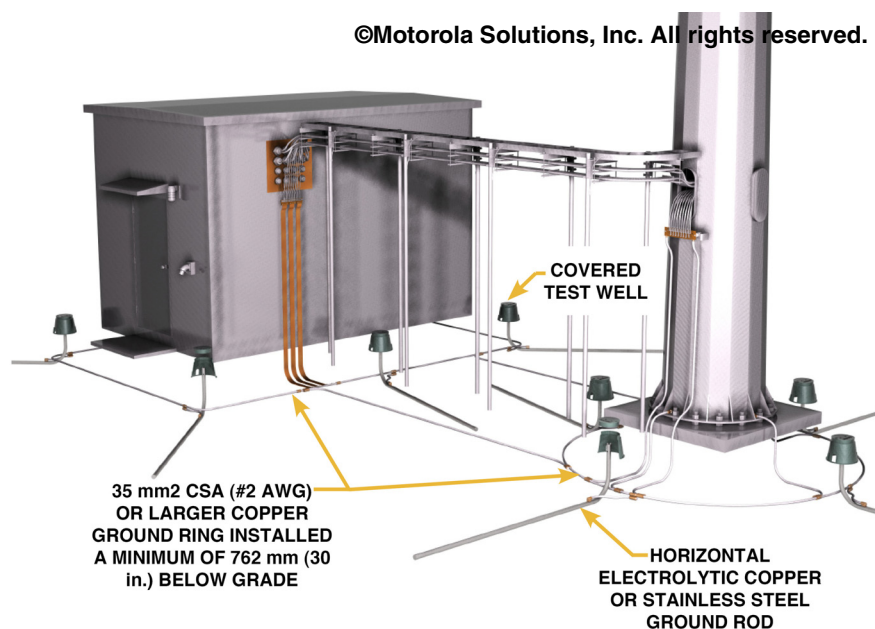

Figure 4-19 Example of Horizontal Electrolytic Ground Rod Installation

- L-shaped electrolytic rods (horizontal portion) **shall** be installed at least 762 mm (30 in.) below grade, where practicable.
- Electrolytic rods should be considered in arctic regions. See “Arctic Environments” on page 4-144.

4.5.1.7 Ground Plate Electrodes

Ground plate electrodes (Figure 4-20) may be used in special cases or if specifically engineered into the design of the grounding electrode system (TIA-607-C, section B.4). Requirements for the use of ground plate electrodes are as follows:

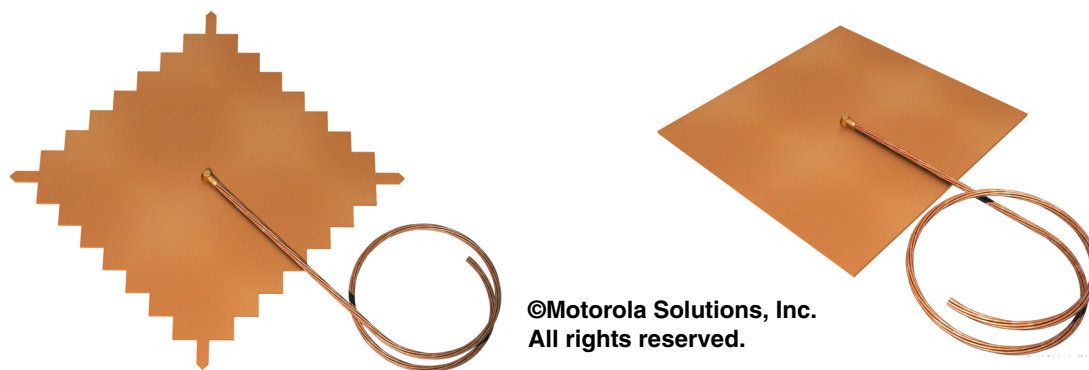

Figure 4-20 Typical Ground Plates



IMPORTANT

Ground plates should only be used where specific soil conditions prohibit the use of ground rods and if specifically engineered into the grounding electrode system.

- Ground plate electrodes **shall** be constructed of copper or copper-clad steel.
- Ground plates **shall** expose not less than 0.186 m² (2 ft²) of surface to exterior soil (MIL-HDBK-419A, section 2.5.5; NFPA 70-2017, Article 250.52; and NFPA 780-2017, section 4.13.6.1).
- Solid copper ground plates **shall** have a minimum thickness of 1.5 mm (0.06 in.) (MIL-HDBK-419A, section 2.5.5; and NFPA 70-2017, Article 250.52).
- Copper-clad steel ground plates **shall** have a minimum thickness of 6.4 mm (0.25 in.) (MIL-HDBK-419A, section 2.5.5; and NFPA 70-2017, Article 250.52).
- Ground plates **shall** be free of paint or other nonconductive coatings (NFPA 70-2017, Article 250.53; and NFPA 780-2017, section 4.13.2.2).
- Where practicable, ground plates **shall** be buried not less than 762 mm (30 in.) below the surface of the earth (NFPA 70-2017, Article 250.53). If soil conditions do not allow the ground plate to be buried at this depth, a burial depth of 460 mm (18 in.) may be considered acceptable (NFPA 780-2017, section 4.13.6.2). See “Shallow Topsoil Environments” on page 4-141 for additional information.
- Where practicable, a ground plate **shall** be embedded below permanent moisture level (BS 7430:2011, Clause 9.5.2; and NFPA 70-2017, Article 250.53).
- A grounding electrode encasement material should be used to backfill around the ground plate to help ensure effective contact with the earth (BS 7430:2011, Clause 9.5.2; FAA STD-019e; and NWSM 30-4106). See “Grounding (Earthing) Electrode Encasement Materials” on page 4-35.
- Ground plates should be installed vertically (Figure 4-21) to allow for minimum excavation and better contact with the soil when backfilling (BS 7430:2011, Clause 9.5.2; IEC 60364-5-54:2011, section D.3.2; and IEEE 142-2007, section 4.2.4).

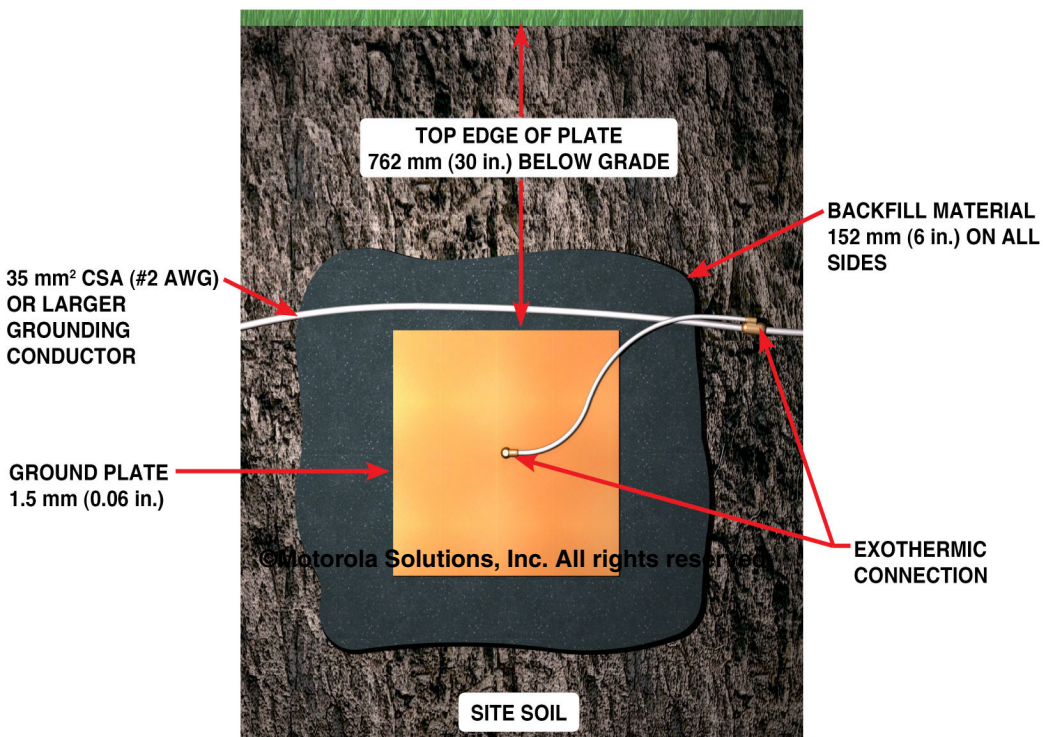

Figure 4-21 Typical Vertical Ground Plate Installation

4.5.1.8 Concrete-Encased Electrodes

Concrete-encased electrodes (also known as foundation earth electrodes or Ufer electrodes, for Herbert G. Ufer) are not required by this standard, but they should be used in new construction as a method of supplementing the grounding electrode system and improving equal potential bonding. Concrete-encased electrodes enhance the effectiveness of the grounding electrode system in two ways: the concrete absorbs and retains moisture from the surrounding soil and provides a much larger surface area in direct contact with the surrounding soil. This is especially helpful at sites with high soil resistivity and/or limited area for installing the grounding electrode system. See IEEE 142-2007 section 4.2.3 and the International Association of Electrical Inspectors publication, *Soares Book on Grounding and Bonding*, 12th edition (ISBN 978-1-890659-65-3), Appendix A, for additional information.

Requirements for use of concrete-encased electrodes are as follows (see IEC 60364-5-54:2011; NFPA 70-2017, Article 250.52; NFPA 780-2017, section 4.13.3; and TIA-607-C, section B.6).

- Concrete-encased electrodes **shall** be encased by at least 51 mm (2 in.) of concrete, located horizontally near the bottom or vertically, and within that portion of a concrete footing or foundation in direct contact with the earth. Figure 4-22 shows examples of horizontal concrete-encased electrodes. Figure 4-23 shows examples of vertical concrete-encased electrodes.
- Concrete-encased electrodes **shall** be at least 6.1 m (20 ft) of bare copper conductor not smaller than 25 mm² csa (#4 AWG) or at least 6.1 m (20 ft) of one or more bars of zinc galvanized or other electrically conductive coated steel reinforcing bars or rods at least 12.7 mm (0.5 in.) in diameter.
- Concrete-encased electrodes **shall** be bonded to any other grounding electrode system at the site. See “Common Grounding” on page 4-6.



IMPORTANT

At a communications site, concrete-encased electrodes shall not be used as the only grounding electrode. Concrete-encased electrodes shall not be used as the only means for tower grounding.

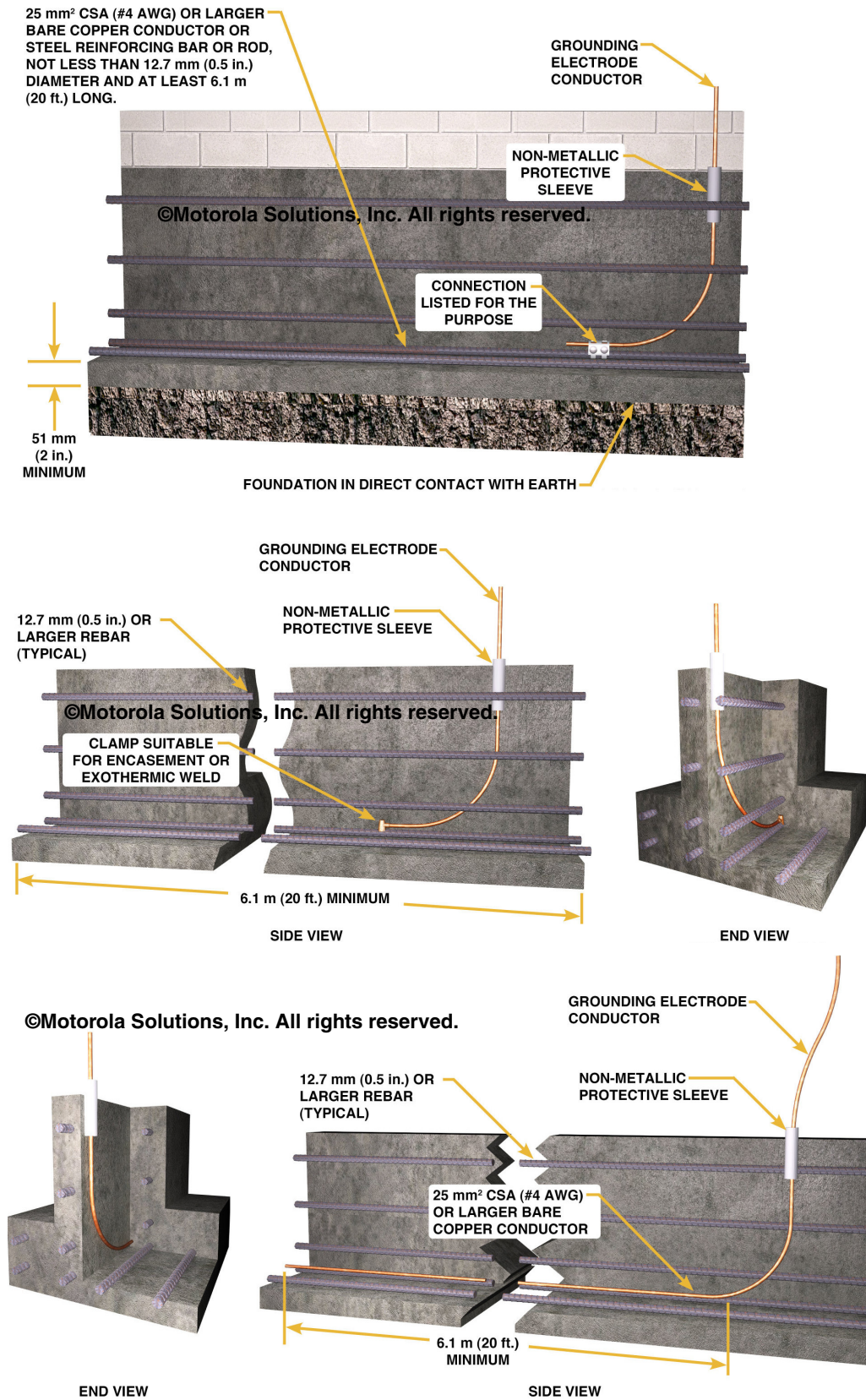

Figure 4-22 Typical Horizontal Concrete-Encased Electrodes



IMPORTANT

Due to potential corrosive effects, galvanized ground rods should not be installed near concrete-encased electrodes. Copper, copper-clad steel or stainless steel rods should be used to help prevent corrosion (IEC 62305-3:2010, section E.5.6.2.2.2).

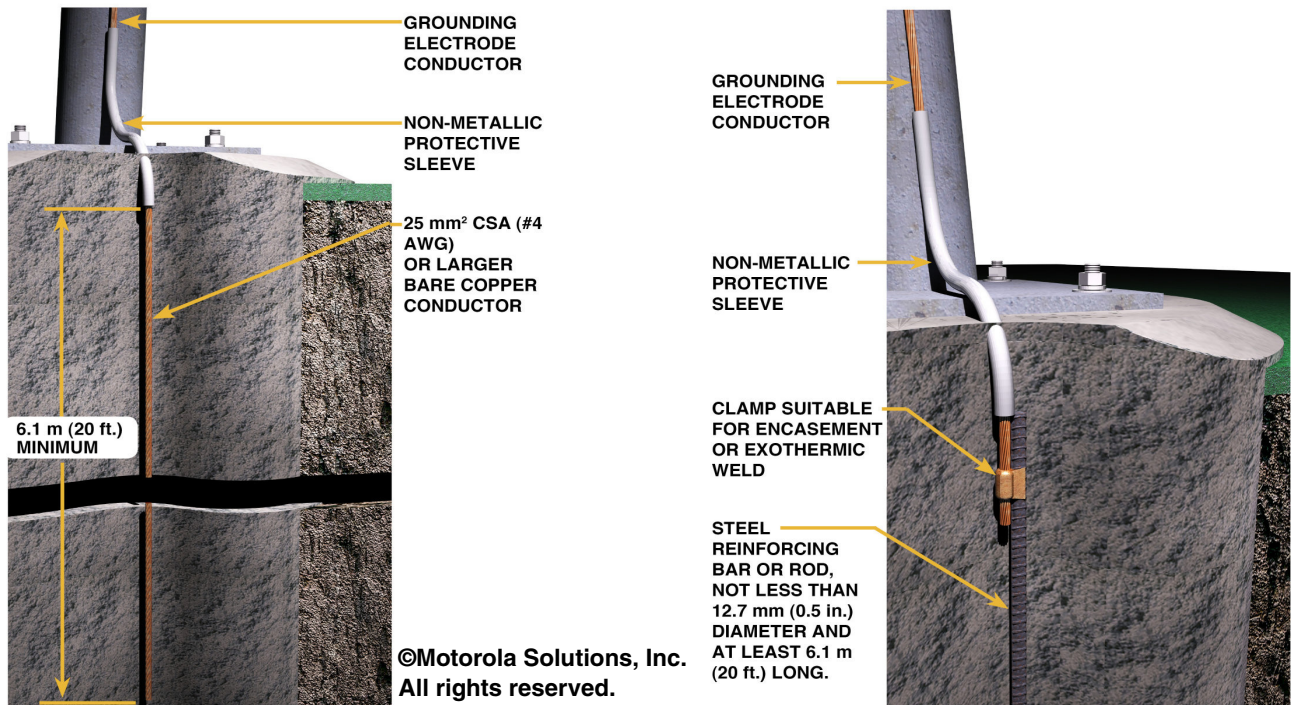

Figure 4-23 Typical Vertical Concrete-Encased Electrodes

4.5.1.9 External Building and Tower Ground Ring

A ground ring (also known as a ring earth electrode) is a buried bare copper conductor encircling the building or structure and in direct contact with the earth. The buried external ground rings (building and tower) provide a means of bonding ground rods together and bonding other grounding electrode system components together, improving the overall grounding electrode system. The ground rings also help to equalize potential in the earth surrounding the tower and building structures, regardless of earth resistivity, by ensuring that a low impedance current path exists throughout the area (ATIS-0600334.2013, section 5.3).

Requirements for external ground rings are as follows. See Figure 4-24 and Figure 4-25 for examples.

- Building ground rings **shall** encircle the building or shelter where practicable (ATIS-0600334.2013, Figure 3(a); ATIS-0600334.2013, section 5.3; MIL-HDBK-419A; and MIL-STD-188-124B).
- Building ground rings **shall** be installed at least 914 mm (3 ft) from the building foundation and should be installed beyond the drip line of the roof. It is recommended that the building ground ring and ground rods be positioned 610 mm to 1.8 m (2 ft to 6 ft) outside the drip line of the building or structure to ensure that precipitation wets the earth around the ground ring and rods (MIL-HDBK-419A and MIL-STD-188-124B).
- Tower ground rings **shall** encircle the tower structure where practicable (ATIS-0600334.2013, section 5.3; and MIL-HDBK-419A).
- Tower ground rings **shall** be installed at least 610 mm (2 ft) from the tower foundation (ATIS-0600334.2013, section 5.3.1).

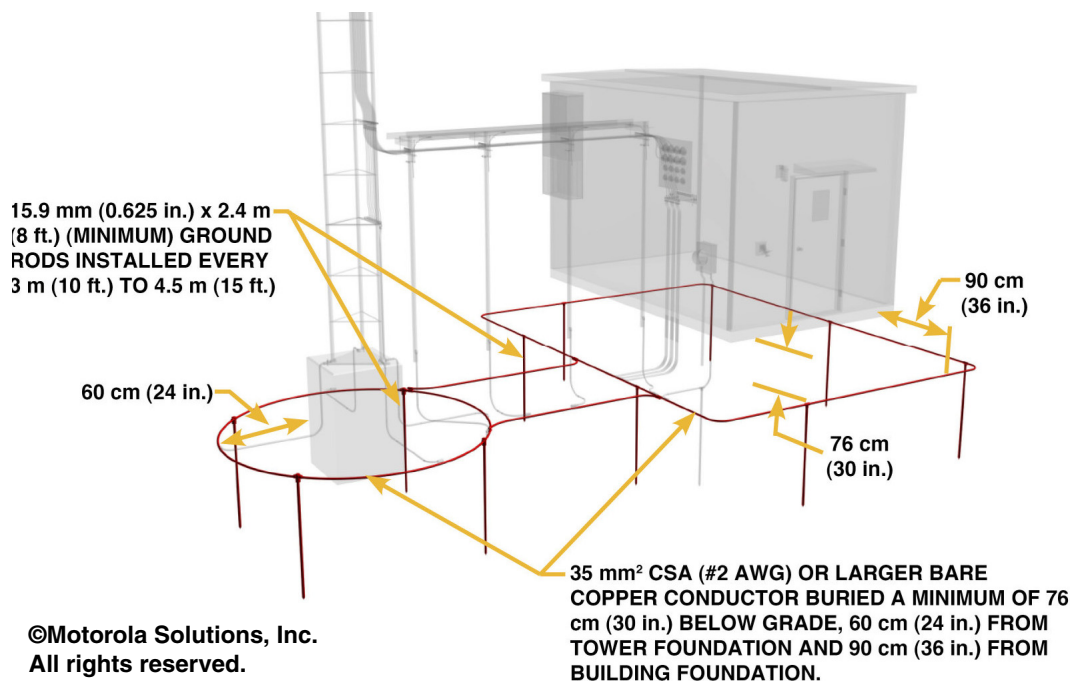

Figure 4-24 Example of Building and Tower Ground Ring

- Where the conductor completely encircles the building, the ends of the conductor **shall** be joined together to form a continuous ring using an exothermic weld or listed irreversible high-compression connector (ATIS-0600334.2013, section 5.3.1, and MIL-STD-188-124B). This may be easily completed at a ground rod.
- Ground rings **shall** be installed in direct contact with the earth at a minimum depth of 762 mm (30 in.) where practicable or below the frost line, whichever is deeper (ATIS-0600334.2013, section 5.3.1; NFPA 70-2017, Article 250.53; TIA-607-C, section B.7; and Telcordia GR-3171-CORE, section 10.2.5).
- The ground ring conductors **shall** be 35 mm² csa (#2 AWG) or larger solid, bare, copper (ATIS-0600313.2013; ATIS-0600334.2013, section 5.3.1; IEEE 1692-2011, section 8.2; and NFPA 70-2017, Article 250.52). Conductors larger than 35 mm² csa (#2 AWG) may be stranded, but should be tinned to help reduce corrosion. See “Grounding (Earthing), Bonding and Down-Conductors” on page 4-37 for grounding conductor specifications.
- **Tinned**-copper conductors should be used to minimize galvanic corrosion between tower legs (and other galvanized items) and other parts of the grounding electrode system (ATIS-0600313.2013, section 10.7; and IEEE 1692-2011, section 8.2).
- For areas highly prone to lightning and/or military installations, larger conductors, such as 50 mm² csa (#1/0 AWG) or larger, should be considered (MIL-HDBK-419A, MIL-STD-188-124B, and TIA-607-C, section B.7); stranded conductors may be used in this application, but should be tinned to help reduce corrosion (see TIA-607-C, section B.7).
- Building ground rings and tower ground rings **shall** be bonded together in at least two points using two 35 mm² csa (#2 AWG) or larger, bare, solid, copper conductors (ATIS-0600334.2013, Figure 1; MIL-STD-188-124B; and TIA-607-C, section C.2.5). The conductors **shall** be buried to the same depth as the ground rings (TIA-607-C, section B.2.5) and should be physically separated as much as practicable. See Figure 4-26.

©Motorola Solutions, Inc. All rights reserved.

35 mm² CSA (#2 AWG) OR LARGER BARE COPPER CONDUCTOR BURIED A MINIMUM OF 76 cm (30 in.) BELOW GRADE AND 60 cm (24 in.) FROM TOWER FOUNDATION AND 90 cm (30 in.) FROM BUILDING FOUNDATION.

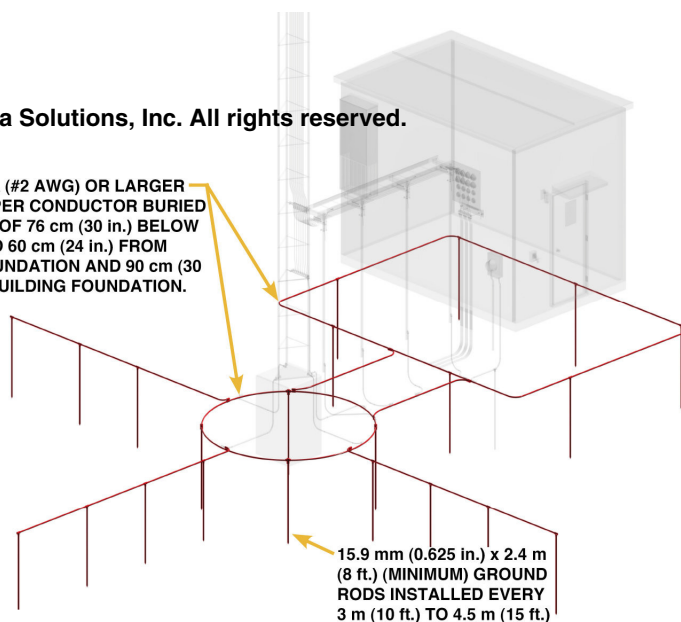

Figure 4-25 Example of Building and Tower Ground Ring With Radials

©Motorola Solutions, Inc. All rights reserved.

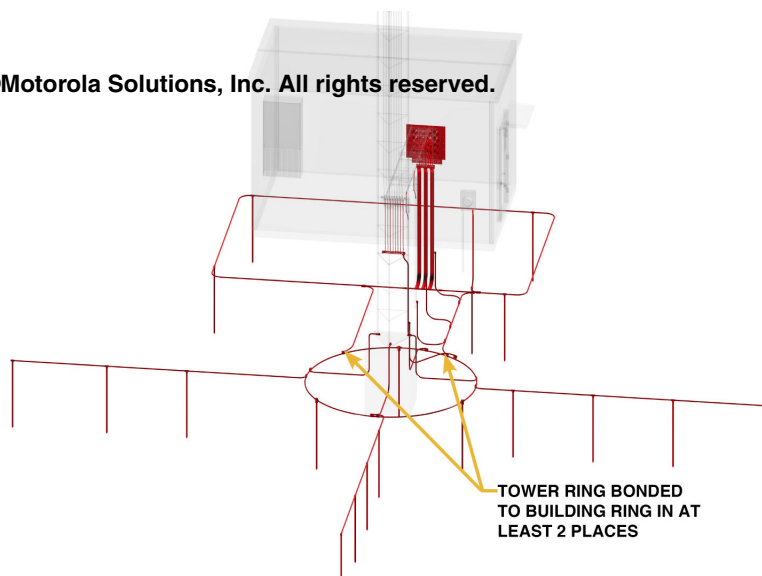

Figure 4-26 Bonding Building and Tower Ground Ring Systems Together

- Ground rods **shall** be installed and connected to the ground ring conductor at 3 m to 4.5 m (10 ft to 15 ft) intervals (ATIS-0600334.2013, section 5.3.2).



NOTE

See Figure 4-105 for an example of the ground ring for closely spaced structures.

4.5.1.10 Radial Grounding Conductors

Radial grounding conductors are conductors installed horizontally in the earth, radiating away from the tower and building (see Figure 4-27). For high lightning-prone areas, normally occupied sites such as 911 dispatch centers, sites with high soil resistivity or situations where bedrock prohibits ground rods from being driven into the soil, radial grounding conductors should be used to improve equalization of the grounding electrode system (see ATIS-0600313.2013, section 10.3.2; and ATIS-0600334.2013, section 5.4), to reduce the impact of Ground Potential Rise (see IEEE 1692-2011) and to help meet the site's grounding electrode system resistance requirements (see “Grounding (Earthing) Electrode System Resistance Requirements” on page 4-76).

NOTE

See “Ground Inspection Wells” on page 4-35, “Testing Prerequisites Not Met” on page D-4, and Figure D-16 for more information on test well locations for clamp-on ground resistance testing.

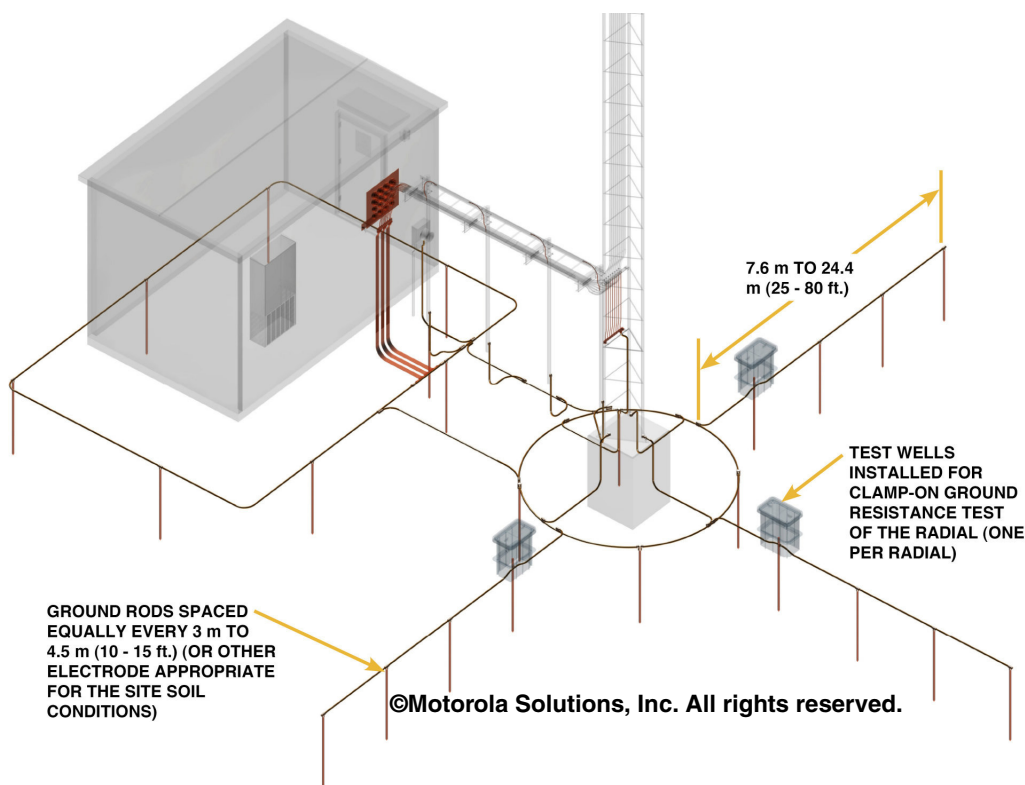

Figure 4-27 Example of Radial Conductors

NOTE

In typical soil resistivity conditions of 10,000 ohm-cm, the addition of five radial conductors 7.6 m (25 ft) in length may reduce the tower grounding electrode system resistance by a factor of two or three. More importantly, adding radial conductors divides lightning strike current into segments that allow for more effective dissipation of energy into the earth, away from the equipment building. See IEEE 1692-2011.

Where used, radial conductors **shall** meet the following specifications:

- The conductors **shall** radiate away from the building and tower (ATIS-0600334.2013, section 5.4; and TIA-607-C, section B.8.)

- The conductors **shall** be constructed of 35 mm² csa (#2 AWG) or larger bare, solid, copper. Conductors larger than 35 mm² csa (#2 AWG) may be stranded, but should be tinned to help reduce corrosion. See “Grounding (Earthing), Bonding and Down-Conductors” on page 4-37 for conductor specifications and installation requirements. (ATIS-0600334.2013, section 5.4)
- The conductors **shall** be buried at least 457 mm (18 in.) below grade level or below the frost line, whichever is deeper (ATIS-0600334.2013, section 5.4). Where topsoil conditions allow, the recommended depth is at least 762 mm (30 in.) (TIA-607-C, section B.8).
- The minimum length of each conductor **shall** be 7.6 m (25 ft) (ATIS-0600334.2013, section 5.4; IEEE 1692-2011, section 8.3; and TIA-607-C, section B.8). If the desired resistance to earth is not achieved at 7.6 m (25 ft), the radial conductor may be extended to help obtain the desired resistance. The maximum effective length for a single radial conductor is generally considered to be approximately 24.4 m (80 ft) (IEEE 1692-2011, section 8.3; and TIA-607-C, section B.8). Adding additional conductors in separate trenches is generally more effective than extending the length of a single conductor.
- A minimum of three radial conductors should be used, where practicable (TIA-607-C, section B.8; and IEEE 1692-2011, section 8.3).
- Where multiple radial conductors are installed, they **shall** be installed in separate trenches. The trenches **shall** be spaced as far apart from one another as practicable and in a manner that maximizes use of the available property area (see TIA-607-C, section B.8).
- The conductors **shall** terminate to the tower ground ring where practicable (see Figure 4-27), but may terminate to the building ground ring in special applications.
- Where the conductors are installed at the tower, the conductors **shall** be bonded directly to the tower and tower ground ring (ATIS-0600334.2013, section 5.4). If it is not practical to bond all radial conductors to the tower, the tower (or each leg on a self-supporting tower) **shall** have additional grounding conductors bonding it to the tower ground ring. See Figure 4-28 for an example of an additional grounding conductor on each tower leg. In this instance, the conductors should be 70 mm² csa (#2/0 AWG) or larger.
- Conductor bonding **shall** comply with “Bonding to the External Grounding and Bonding System” on page 4-57.

**NOTE**

Where soil conditions allow, the effectiveness of the radial grounding conductor may be increased by including a ground rod every 3 m to 4.5 m (10 ft to 15 ft) (see TIA-607-C, section B.8).

**NOTE**

Low resistance in radial grounding configurations is desirable, but not critical. Low resistance in the dissipating path of strike currents into the earth is of secondary importance when compared to the primary objective of controlling voltage gradients and voltage differences between structures and equipment close to the tower (ATIS-0600334.2013, section 5.4).

**NOTE**

Where multiple radial conductors are used, the conductors should be of different lengths (such as $\pm 5\%$) to help prevent resonant “ringing” of the tower during a lightning strike (see TIA-607-C, section B.8).

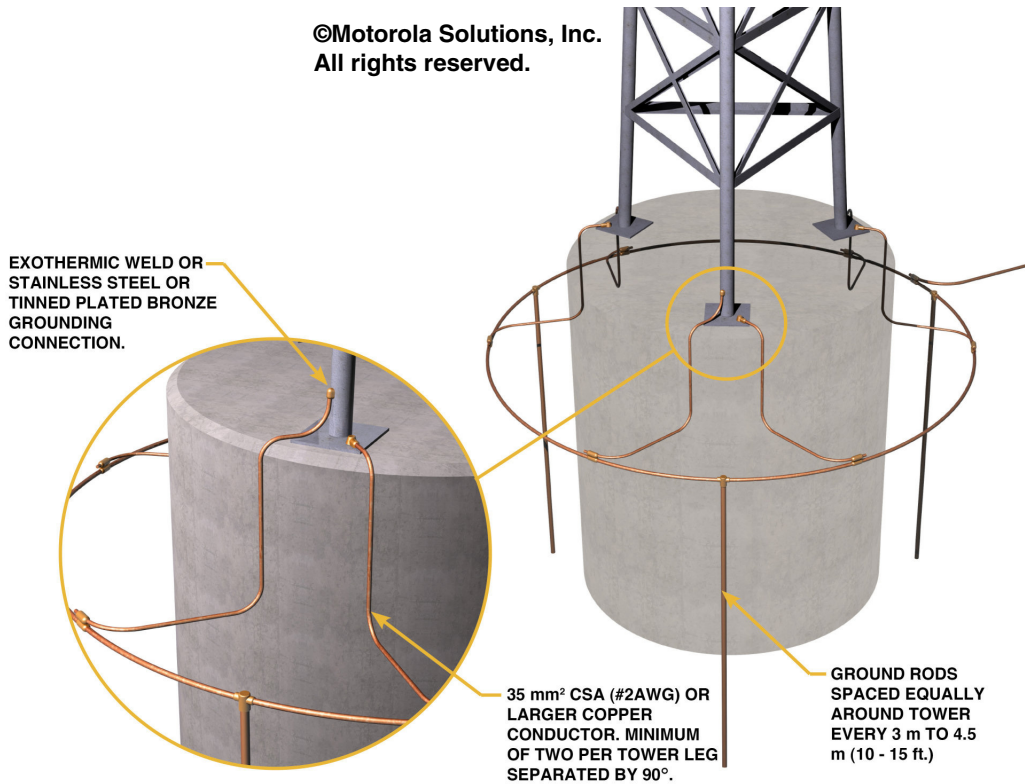

Figure 4-28 Example of an Additional Grounding Conductor Installed on Each Tower Leg (Radials Not Shown)

The resistance to earth of a straight horizontal electrode (radial grounding conductor) may be calculated as follows:

$$R = \frac{\rho}{\pi L} \left[\ln \left(2 \frac{L}{\sqrt{2aD}} \right) - 1 \right]$$

Where:

$D \ll L$ (D is much less than L)

R : The resistance of the electrode in ohms

ρ : The soil resistivity in ohm-meters

L : The length of the conductor in meters

a : The conductor radius in meters

D : The conductor depth in meters

The resistance can also be calculated using the [Radial Grounding Conductor Calculator](#) tool provided with this manual.

Figure 4-29 shows the resistance characteristics of a radial grounding conductor.

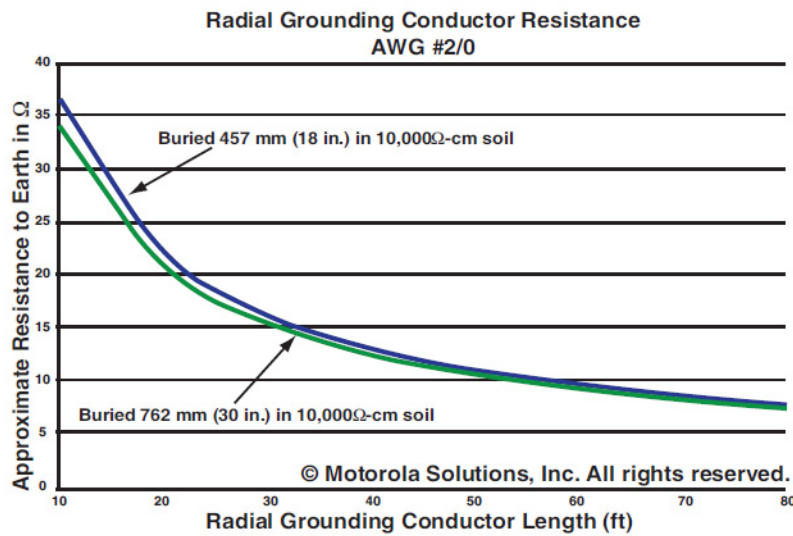
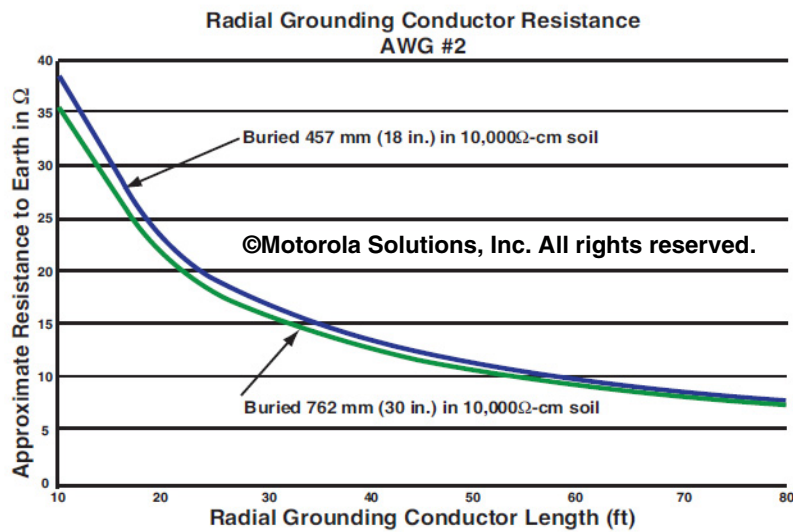

Figure 4-29 Resistance Characteristics of a Radial Grounding Conductor



IMPORTANT

Areas of high lightning exposure or high soil resistivity should utilize supplemental grounding, such as radial grounding conductors (see ATIS-0600313.2013, section 10.3.2).



IMPORTANT

Radial grounding conductors should be installed at dispatch center sites that have a co-located tower. See “Dispatch Centers Co-Located With Communications Towers” on page 4-122.

**IMPORTANT**

IEEE 1692-2011, section 8.2, recommends a conductive cement be used on radial grounding conductors where the soil resistivity exceeds 500 ohm-m. See “Grounding (Earthing) Electrode Encasement Materials” on page 4-35.

4.5.1.11 Wire Mesh

Wire mesh is a prefabricated grounding conductor mesh designed for the purpose of grounding. Wire mesh is installed horizontally in the earth or on the earth's surface if site specific soil conditions do not permit burying. Metallic objects at the site that require grounding/bonding (such as external ground bus bar, tower, fuel tank, fence, and so on) are bonded to the wire mesh.

The use of wire mesh is a simple method to obtain equal potential at sites where there is very little room for the grounding electrode system or at sites where the installation of other grounding electrodes is prohibited by soil conditions (such as shallow topsoil on stone mountaintops) (TIA-607-C, section B.5). See “Special Situations” on page 4-134 for wire mesh installation applications.

**NOTE**

If the wire mesh is constructed from 35 mm² csa (#2 AWG) conductors, and the building and tower are already surrounded by the wire mesh, the building and tower do not require separate ground rings.

If the wire mesh is constructed from 16 mm² csa (#6 AWG) conductors, the building and tower require ground rings as described in “External Building and Tower Ground Ring” on page 4-25. The wire mesh and ground rings **shall** then be bonded together at equally spaced intervals not exceeding 3 m (10 ft).

Requirements for using prefabricated wire mesh are as follows:

- The wire mesh **shall** be listed by a Nationally Recognized Testing Laboratory (NRTL), such as CSA C22.2 NO. 41-07 or UL 467-2007.
- The wire mesh **shall** be installed according to manufacturer instructions.
- The wire mesh **shall** be constructed from copper, tinned-copper or stainless steel conductor (CSA C22.2 NO. 41-07 and UL 467-2007, section 6.10).
- The wire mesh **shall** be constructed from 16 mm² csa (#6 AWG) or larger conductor. If the wire mesh is constructed from 35mm² csa (#2 AWG) conductors, separate building and tower ground rings are not required if the wire mesh surrounds the building and tower.
- The wire mesh conductors **shall** be brazed, welded or exothermically bonded together at all intersection points (see ITU *Earthing and Bonding Handbook*, section 3.5).
- The wire mesh grid pattern **shall not** have any dimension less than 102 mm (4 in.) (CSA C22.2 NO. 41-07 and UL 467-2007, section 6.10). See Figure 4-30.
- The wire mesh grid pattern **shall not** have any dimension greater than 610 mm (24 in.) (CSA C22.2 NO. 41-07 and UL 467-2007, section 6.10). See Figure 4-30.
- The wire mesh **shall** be bonded to any other grounding electrodes at the site. See “Common Grounding” on page 4-6.
- If building and/or tower ground rings are used, they **shall** bond to the wire mesh at equally spaced intervals not exceeding 3 m (10 ft).

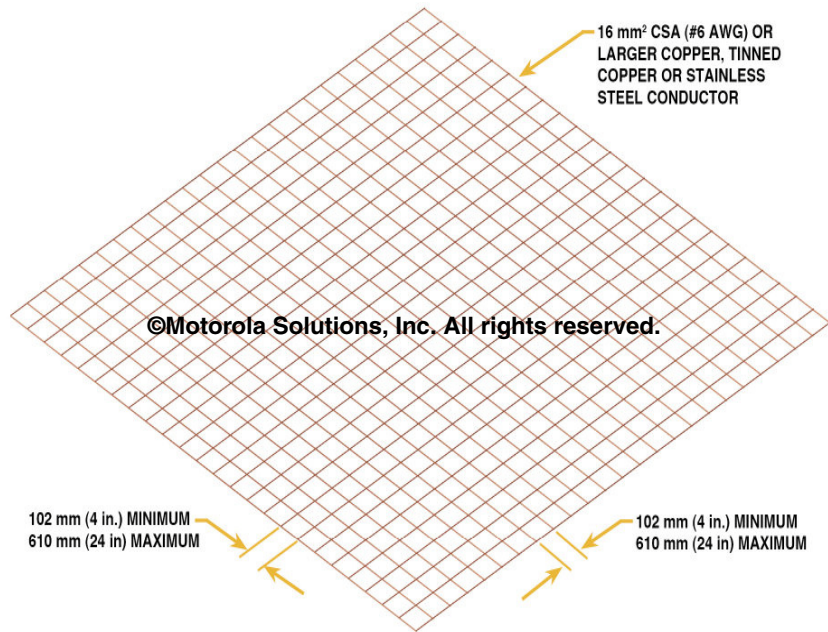

Figure 4-30 Example of Wire Mesh

4.5.1.11.1 Sites with Topsoil

- The wire mesh **shall** be buried to a minimum depth of 457 mm (18 in.) if practicable or as otherwise allowed by the site specific soil conditions. See Figure 4-31 and Figure 4-32.



Figure 4-31 Typical Wire Mesh Installation at Site with Limited Space (Ground Cover Not Shown)

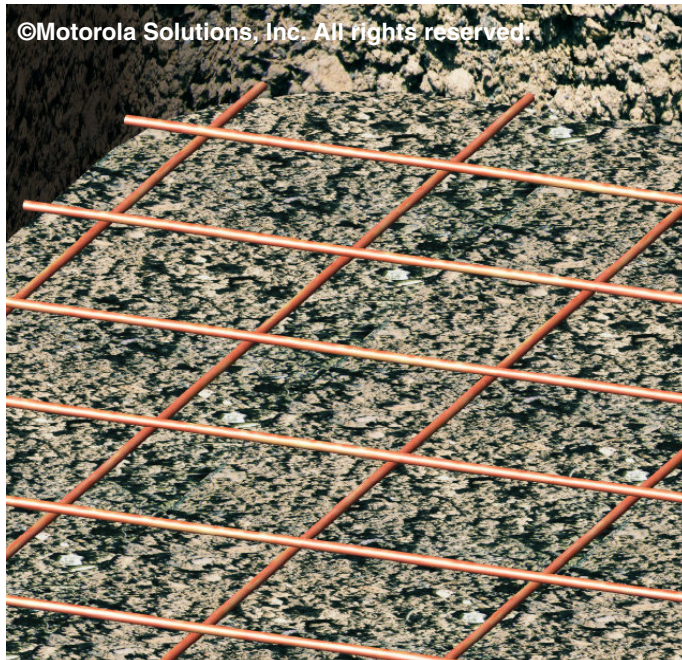

Figure 4-32 Wire Mesh Close-up View (Ground Cover Not Shown)

4.5.1.11.2 Sites Without Topsoil

- The wire mesh **shall** be properly secured in place using one of the following techniques:
 - Securing the mesh to the rock surface with appropriate hardware at least every 1 m (3 ft). See Figure 4-33.

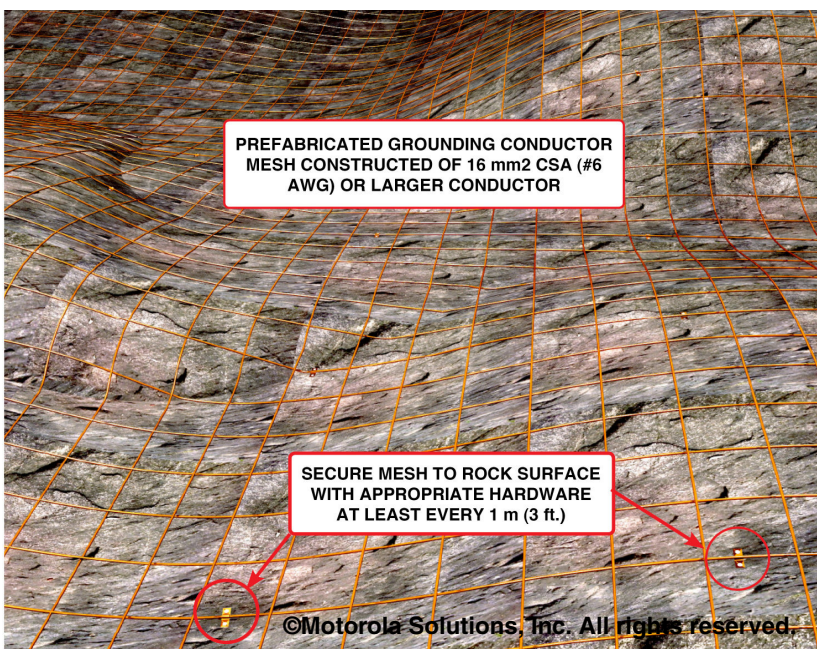

Figure 4-33 Wire Mesh Attached to Rock Surface at Sites Without Topsoil

- Covering the wire mesh with at least 15 cm (6 in.) of top soil (native or imported). Covering the mesh with topsoil improves the resistance to earth and may also help prevent theft. It is recommended to cover the top soil with landscaping fabric and then cover the fabric with approximately 5 cm (2 in.) of gravel.
- Protecting and securing the wire mesh with a conductive-type concrete.
- Other methods deemed practicable for the site-specific conditions.

4.5.1.12 Ground Inspection Wells

Ground test wells are not required, but may be desired for inspecting the grounding electrode system components. Larger tests wells (hand-holes) may be installed at strategic locations to allow for easy clamp-on ground resistance meter (clamp-on ohmmeter) testing of portions (see Figure 4-27) or all of the grounding electrode system. See Figure 4-34 and Figure D-16.

Ground inspection wells are typically constructed of PVC tubing 203 mm (8 in.) or more in diameter and have a detachable cover to keep debris out. A typical ground inspection well is shown in Figure 4-34.

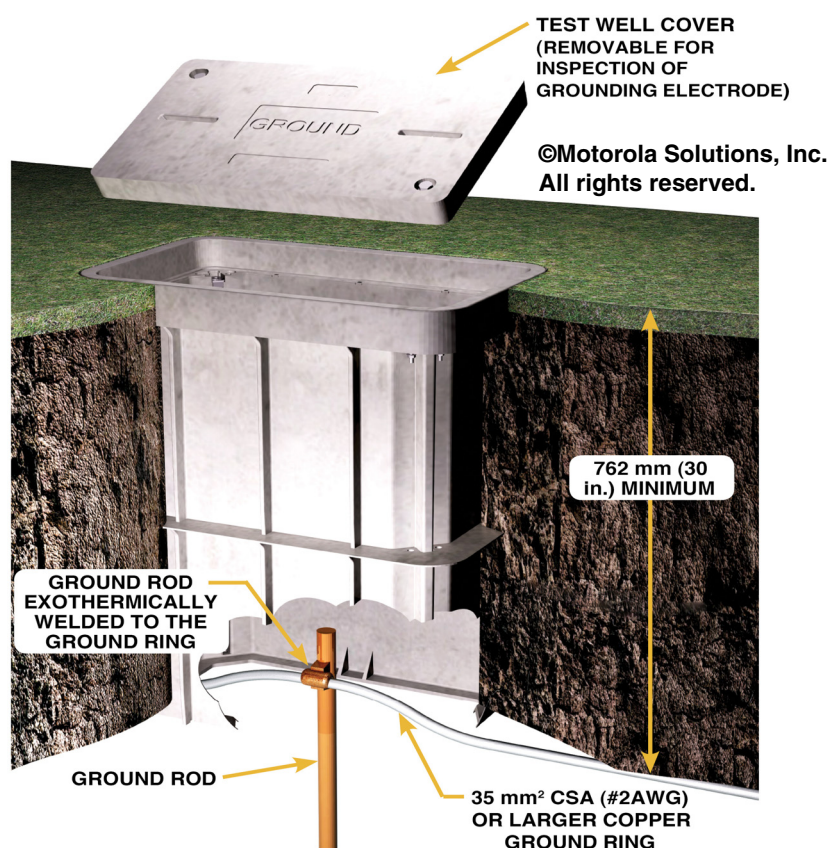

Figure 4-34 Typical Ground Inspection Well

4.5.1.13 Grounding (Earthing) Electrode Encasement Materials

The resistance to earth of a grounding electrode is directly proportional to soil resistivity and inversely proportional to the total area in contact with the soil. Grounding electrode encasement materials (also known as backfill, ground enhancing material or engineered soil) may consist of the following: bentonite-containing material, coke breeze or other carbon-based material, concrete or conductive concrete or cement made with graded granular carbonaceous aggregate in place of the conventional sand or gravel. Grounding electrode encasement materials can absorb water from surrounding soil and have hydration and water retention properties. When placed around grounding electrodes and their interconnecting cable, grounding electrode encasement materials greatly increase the effective area in contact with soil, which in turn reduces the resistance of the grounding electrode system. See IEEE 1692-2011, section 8.2; MIL-HDBK-419A Volume I, section 2.9; and BS 7430:2011, Clause 9.2.2 for more details.

Grounding electrode encasement material may be used as needed to improve the grounding electrode system resistance and/or to protect grounding electrode system components from corrosive soil (see BS 7430:1998, Clauses 8.5 and 19.6.1; and BS 7430:2011, Clause 9.10.1.NOTE). Grounding electrode encasement material is generally used with electrolytic ground rods, but may also be used on grounding conductors, standard ground rods and ground plates as a way to improve the resistance to earth of a grounding electrode system (see TIA-607-C, section B.9). See Figure 4-35 for examples.

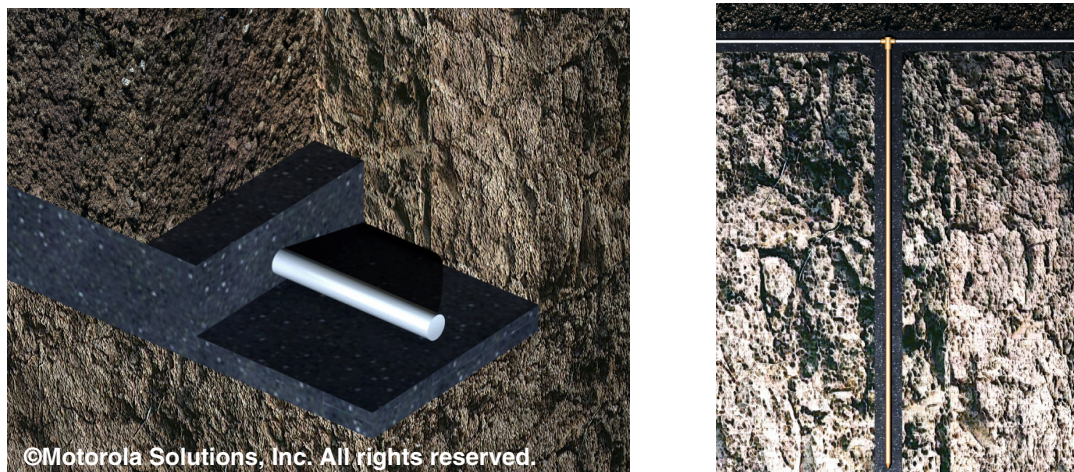

Figure 4-35 Grounding Electrode Encasement Material Covering Grounding Electrode System Components

Requirements for the use of grounding electrode encasement material are as follows:

- Grounding electrode encasement material **shall** be packaged for the purpose of grounding electrode encasement.
- Grounding electrode encasement material **shall** be environmentally safe and approved by the environmental Authority Having Jurisdiction.
- Grounding electrode encasement material **shall** be used according to the manufacturers' instructions.
- Grounding electrode encasement material **shall not** have a corrosive effect. The material should have a neutral pH (concentration of hydrogen ions) in the 6-8 range. See Table 4-9 for addition information on corrosion related to pH.
- Coke breeze or other carbon-based products **shall not** contain more than 1% sulfur by weight.

Coke breeze derived from coal in coke ovens may be used. Charcoal or petroleum-based coke breeze **shall not** be used unless it contains less than 1% sulfur by weight; more sulfur may cause rapid corrosion of copper electrodes and copper conductors (FAA STD 019e-2005, section 4.2.4.3.4). Charcoal or petroleum-based coke typically contains high levels of sulfur, which accelerates corrosion in the presence of moisture. Coke breeze derived from coal in coke ovens is generally considered acceptable because the corrosives and volatiles have been cooked off at extremely high temperatures (NWSM 30-4106-2005, section 2.8.2.4).

IEEE 1692-2011, section 8.2, recommends a conductive cement. Conductive cement is further recommended to be used on radial grounding conductors when the soil resistivity exceeds 500 Ω -m.

Per MIL-HDBK-419A and the ITU *Earthing and Bonding Handbook*, the suggested grounding electrode encasement (backfill) material is a mixture of 75 percent gypsum, 20 percent bentonite clay and 5 percent sodium sulfate. The gypsum, which is calcium sulfate, absorbs and retains moisture and adds reactivity and conductivity to the mixture. Because it contracts very little when moisture is lost, it will not pull away from the ground rod or surrounding earth. The bentonite ensures good contact between the ground rod and earth by its expansion, while the sodium sulfate prevents polarization of the ground rod by removing the gases formed by current entering the earth through the ground rod. This mixture is readily available from cathodic protection distributors as standard galvanic anode backfill. The backfill mixture should be covered with 305 mm (12 in.) of excavated soil. See MIL-HDBK-419A Volume I, section 2.9, and the ITU *Earthing and Bonding Handbook*, section 3.9, for additional information.

**IMPORTANT**

Coke breeze or other carbon-based products that contain more than 1% sulfur by weight shall not be used. These products, when in the presence of moisture will accelerate corrosion. See FAA-STD-019e, section 4.2.4.3.4.

4.6 Grounding (Earthing), Bonding and Down-Conductors

Conductors are used to connect grounding electrodes together, form buried ground rings or to connect objects to the grounding electrode system. See BS 7430:2011 and NFPA 70-2017, Article 100, for additional information.

4.6.1 General Specifications

General specifications for grounding conductors are as follows:

- Unless otherwise specified, all grounding and bonding conductors **shall** be copper (ATIS-0600334.2013, section 5.1).
- Below-grade grounding conductors **shall** be bare (ATIS-0600334.2013, section 5.1).
- Unless otherwise specified, all below-grade grounding conductors **shall** be solid (ATIS-0600334.2013, section 5.1). Conductors larger than 35 mm² csa (#2 AWG) may be stranded, but should be tinned to help reduce corrosion.
- Tinned-copper conductors should be used to help minimize galvanic corrosion between tower legs (and other galvanized steel objects) and other parts of the grounding electrode system (ATIS-0600313.2013, section 10.7). See “Dissimilar Metals and Corrosion Control” on page 4-52.
- Tinned-copper conductors **shall** be used when bonding to tower legs and other galvanized steel items with mechanical clamps (IEC 62305-3:2010, section E.5.6.2.2.1).
- Below-grade or partially below-grade bonding conductors **shall** be 35 mm² csa (#2 AWG) or larger (ATIS-0600313.2013, Figure 3(a)).
- Bonding conductors routed horizontally below grade (such as the bonding jumper from a generator or fuel tank to the ground ring) **shall** be buried deep enough to provide conductor protection and not create a trip hazard. The recommended depth is no less than 46 cm (18 in).
- For high lightning prone areas and/or military installations, larger conductors, such as 50 mm² csa (#1/0 AWG) or larger, should be considered for the ground ring (see MIL-HDBK-419A and TIA-222-G). Grounding conductors larger than 35 mm² csa (#2 AWG) may be stranded, but should be tinned to help reduce corrosion.
- Grounding electrode conductors **shall** be installed in one continuous length without a splice or joint, unless spliced using exothermic welding or listed irreversible high-compression connectors (NFPA 70-2017, Article 250.64). See “Bonding to the External Grounding and Bonding System” on page 4-57 for additional information.
- Above-grade bonding conductors should be jacketed (ATIS-0600313.2013, section 11.3). Jacketed conductors help prevent unintentional contact between the copper conductor and metallic objects. Unintentional contact may create corrosion points.
- Above-grade bonding conductors used for bonding individual metallic objects **shall** be 16 mm² csa (#6 AWG) or larger (ATIS-0600334.2013, section 5.3.3). See “Metallic Objects Requiring Bonding” on page 4-101 for additional information.
- Above-grade bonding conductors used for bonding multiple metallic objects (used as a ground bus conductor) **shall** be 35 mm² csa (#2 AWG) or larger. See “Metallic Objects Requiring Bonding” on page 4-101.
- Solid straps or bars may be used as long as the cross-sectional area equals or exceeds that of the specified grounding conductor.
- Above-grade jacketed bonding conductors exposed to direct sunlight **shall** have a UV resistant-rated jacket.

**IMPORTANT**

Flat braided conductors shall not be used in the external grounding system. Flat braided conductors corrode easily and can become a point for RF interference.

**IMPORTANT**

Unless otherwise allowed in this chapter, aluminum conductors shall not be used. See NFPA 70-2017, Article 250.64, and NFPA 780-2017 for more information.

**NOTE**

To help prevent corrosion, tinned-copper conductors should be used throughout the grounding electrode system.

4.6.2 Bending and Routing Grounding (Earthing), Bonding and Down-Conductors

The following requirements apply to all grounding, bonding and down conductors:

- Sharp bends **shall** be avoided (ATIS-0600313.2013, section 11.3; ATIS-0600334.2013, section 13.4; and IEEE 1692-2011, section 5.2.3).
- Grounding, bonding and down conductor bending radius **shall not** be less than 0.2 m (8 in.) and the conductor bend angles (included angle) **shall not** be less than 90 degrees (ATIS-0600313.2013, section 11.3; IEEE 142-2007, section 3.3.3.4; MIL-STD-188-124B; NFPA 780-2008, section 4.9.5; and TIA-607-C, section B.10). A diagonal run is preferable to a bend even though it does not follow the contour or run parallel to the supporting structure. See Figure 4-36.
- Grounding, bonding and down conductors **shall** be run as short, straight and smoothly as practicable, with the fewest possible number of bends and curves (ATIS-0600313.2013, section 11.3; ATIS-0600334.2013, section 13.4; IEEE 1692-2011, section 5.2.3; NFPA 70-2017, Articles 770.100, 800.100, 810.21, 820.100 and 830.100).
- Grounding, bonding and down conductors **shall** be run in a direct manner with no sharp bends or narrow loops (ATIS-0600313.2013, section 11.3; ATIS-0600334.2013, section 13.4; and NFPA 70-2017, Articles 770.100, 800.100, 810.21, 820.100 and 830.100). Sharp bends and/or narrow loops increase the impedance and may produce flash points (also see NFPA 780-2017, section 4.9.5)
- All bends and curves **shall** be made toward the ground location (grounding electrode system or ground bus bar).

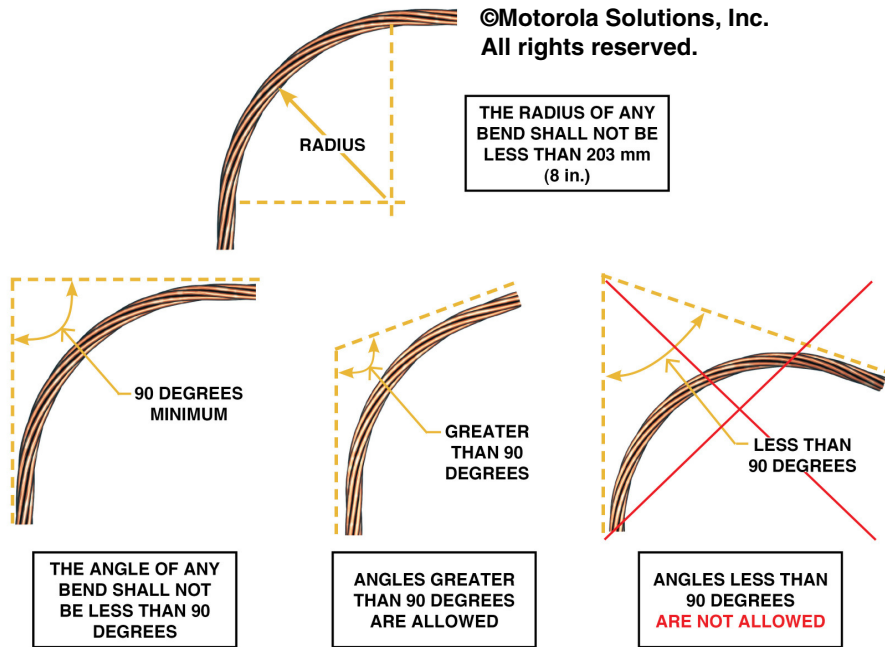

Figure 4-36 Minimum Bending Radius

4.6.3 Protecting and Securing Grounding, Bonding and Down-Conductors

Above-grade external grounding conductors, including straps, are exposed to movement by wind and other forces that can lead to damage or breakage over time. All grounding, bonding and down-conductors **shall** be appropriately protected and secured.

The following requirements apply when installing grounding and bonding conductors:

- Conductors **shall** be protected where exposed to potential physical damage (NFPA 70-2017, Articles 250.64, 770.100, 800.100, 810.21, 820.100, 830.100; and NFPA 780-2017, section 4.9.11). Such damage may arise from foot traffic or lawn maintenance equipment.
- Conductors exposed to damage **shall** be protected in a non-metallic conduit. The conduit should extend 30 cm (12 in.) above grade and 15 cm (6 in.) below grade.
- Down-conductors exposed to physical damage **shall** be protected for a minimum distance of 1.8 m (6 ft) above grade level, where applicable (NFPA 780-2017, section 4.9.11.2). Such areas may include, but are not limited to, runways, driveways, school playgrounds, cattle yards and public walks (NFPA 780-2017, section 4.9.11). See “Down-Conductors” on page 4-40.
- Metallic guards and/or conduits used to protect conductors **shall** be bonded to the grounding conductor at both ends (ATIS-0600313.2013, section 11.4; NFPA 70-2017, Articles 250.64, 770.100, 800.100, 810.21, 820.100, 830.100; and NFPA 780-2017, section 4.9.11.1).



IMPORTANT

Where conduit is used, it should be non-metallic (ATIS-0600313.2013, section 11.4).

- The conductor or its enclosure **shall** be securely fastened to the surface on which it is carried (NFPA 70-2017, Articles 250.64 and 810.21; and NFPA 780-2017, section 4.10).
- Above-grade conductors **shall** be securely fastened at intervals not exceeding 91 cm (3 ft), where practicable (ATIS-0600313.2013, section 8.3 and NFPA 780-2017, section 4.10).
- Conductors **shall** be secured using appropriate hardware intended for the purpose.

- Where metallic fasteners are used on bare conductors, fasteners of the same material (or compatible) **shall** be used. See NFPA 780-2017, section 4.10.4, for additional information.
- Ferrous metallic fasteners that fully encircle the conductor **shall not** be used. These type of fasteners can form a choke point, resulting in a high impedance point.

4.6.3.1 Protecting and Securing Copper Strap

Copper strap **shall** be secured and protected in the same general manner described for conductors. Because copper strap can act as an airfoil in windy conditions, additional securing may be required to prevent damage to the strap. A continuous protective covering designed for the purpose is recommended for protecting and securing copper strap (see Figure 4-37).

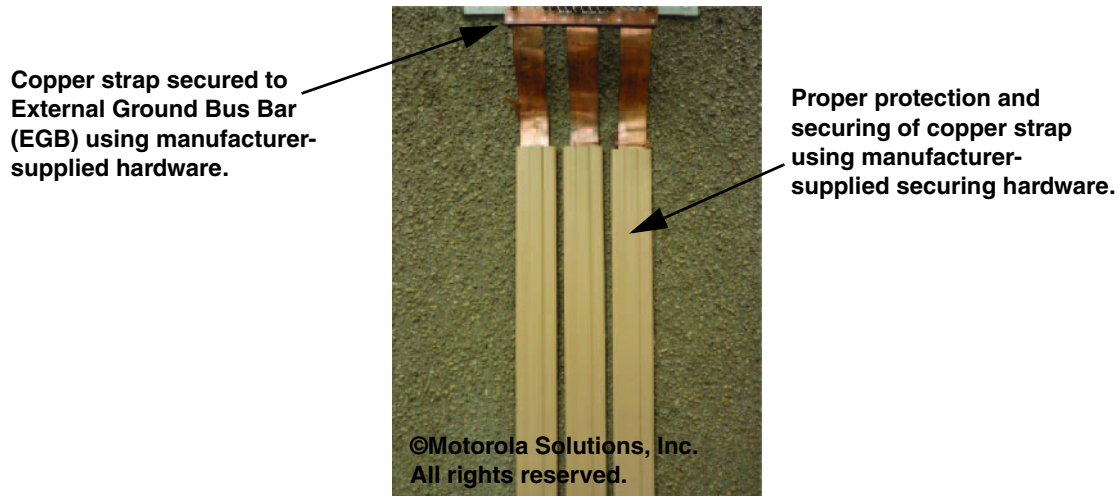

Figure 4-37 Example of Protecting and Securing Copper Strap

4.6.3.2 Down-Conductors

Down-conductors are conductors used to transfer objectionable or unwanted electrical currents and surges to earth from high locations, such as building rooftops. In some applications down-conductors are required in order to bond to the grounding electrode system. Such applications may include, but are not limited to, the following:

- Roof-mounted antennas
- Side-mounted antennas
- Rooftop-mounted towers
- Rooftop communications sites
- Roof- or side-mounted Access Points, Wireless Routers, Point-to-Points and similar devices

4.6.3.2.1 Down-Conductor Sizing

Where bonding to the common grounding electrode system is accomplished utilizing a lightning protection system, the down-conductors **shall** be the same size as the lightning protection system main conductor, based on building height (see NFPA 780-2017, section 4.1, and the associated subsections). Listed aluminum lightning protection system conductors are permitted, but **shall not** be installed below-grade or within 457 mm (18 in.) of grade.



IMPORTANT

If aluminum lightning protection system conductors are used, they shall not be attached to a surface coated with alkaline-base paint, embedded in concrete or masonry, or installed in a location subject to excessive moisture (NFPA 780-2017, section 4.5.3).

**IMPORTANT**

Aluminum grounding conductors shall not be installed below-grade or within 460 mm (18 in.) of grade (NFPA 780-2017, sections 4.2.2.3.1 and 4.5.2).

**NOTE**

Lightning protection system conductors **shall** be listed for the purpose.

See Figure 4-38 for an example of aluminum conductor that transitions to copper prior to entering the earth.

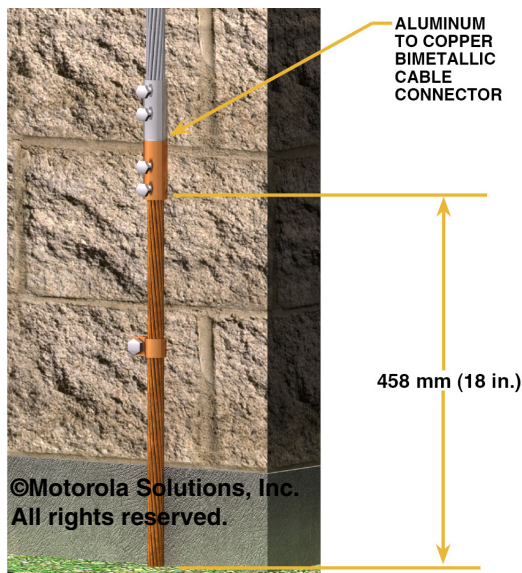

Figure 4-38 Aluminum Lightning Protection System Conductor Transitioning to Copper Prior to Entering Earth

If a listed lightning protection system conductor is used, it **shall** be sized appropriately according to the structure height. See Table 4-3 and Table 4-4 for lightning protection system grounding conductors sizing information (NFPA 780-2017, section 4.1, and associated subsections).

Table 4-3 LIGHTNING PROTECTION SYSTEM GROUNDING CONDUCTORS FOR STRUCTURES LESS THAN 22.9 M (75 FT) TALL (CLASS I CONDUCTOR)

Conductor Parameter	Copper		Aluminum	
	SI	US	SI	US
Size of each strand		17 AWG		14 AWG
Weight per length	278 g/m	187 lb./1000 ft	141 g/m	95 lb./1000 ft
Cross-section area	29 mm ²	57,400 cir. mils	50 mm ²	98,600 cir. mils

Table 4-4 LIGHTNING PROTECTION SYSTEM GROUNDING CONDUCTORS FOR STRUCTURES EQUAL TO OR GREATER THAN 22.9 M (75 FT) TALL (CLASS II CONDUCTOR)

Conductor Parameter	Copper		Aluminum	
	SI	US	SI	US
Size of each strand		15 AWG		13 AWG
Weight per length	558 g/m	375 lb./1000 ft	283 g/m	190 lb./1000 ft
Cross-section area	58 mm ²	115,000 cir. mils	97 mm ²	192,000 cir. mils

Where a lightning protection system is not installed, the down-conductor **shall** be sized according to length as shown in Table 4-5, or a listed lightning protection system conductor may be used (see Figure 4-39).

Table 4-5 GROUNDING DOWN-CONDUCTOR SIZING (FROM MIL-HDBK-419-A)

Conductor length in linear m (ft)	Conductor size in mm ² csa (AWG / MCM)
Less than 10 (Less than 33)	33.62 (2)
10.36 – 12.5 (34 – 41)	42.4 (1)
12.8 – 16 (42 – 53)	52 (1/0)
16.5 – 20 (54 – 66)	67.4 (2/0)
20.4 – 25.6 (67 – 84)	85 (3/0)
25.9 – 32 (85 – 105)	107 (4/0)
32.3 – 38.1 (106 – 125)	126.70 (250 MCM)
38.4 – 45.7 (126 – 150)	152 (300 MCM)
46 – 53.34 (151 – 175)	177 (350 MCM)
53 – 76.1 (176 – 250)	253.4 (500 MCM)
76.4 – 91.39 (251 – 300)	300 (600 MCM)
Greater than 91.39 (300)	380 (750 MCM)

Table 4-6 STANDARD WIRE SIZES AVAILABLE FOR INTERNATIONAL MARKET

Conductor size in mm ² csa	Conductor size in AWG / MCM
6	10
10	8
16	6
25	4
35	2

Table 4-6 STANDARD WIRE SIZES AVAILABLE FOR INTERNATIONAL MARKET (CONTINUED)

Conductor size in mm ² csa	Conductor size in AWG / MCM
50	1/0
70	2/0
95	3/0
120	4/0
150	300 MCM
185	350 MCM
240	500 MCM
300	600 MCM
400	750 MCM

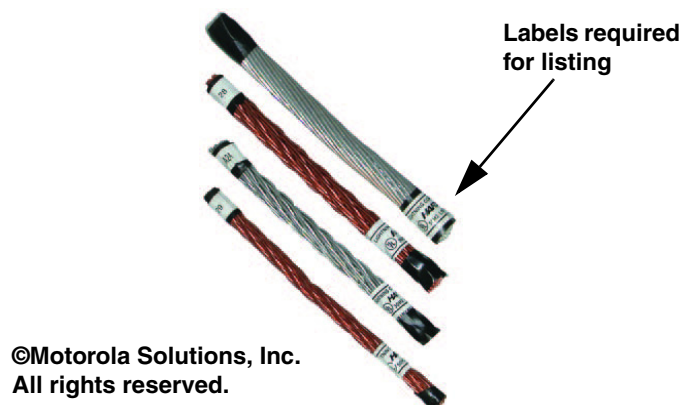
**Figure 4-39** Lightning Protection System Grounding Conductor Examples

4.6.4 External Ground Bus Bar

The purpose of the External Ground Bus bar (EGB) is to provide a convenient grounding termination point for antenna transmission lines (coaxial cables) and other cables prior to their entry into a building or shelter (ATIS-0600313.2013 and ATIS-0600334.2013, section 7.5).

Antenna transmission lines (including waveguide) and other communications cables with metallic shields (and/or grounding conductor) **shall** be grounded as close as practicable to their point of entry into the building or shelter (ATIS-0600334.2013, section 6.6, and NFPA 70-2017, articles 770.93, 800.100, 820.93, 820.100, 830.93 and 830.100).

Requirements for EGB bars, where used, are as follows:

- The EGB **shall** be constructed and minimally sized according to Table 4-7, ensuring the ground bus bar is large enough to accommodate all transmission lines and other grounding connections.
- The EGB **shall** be designed for the purpose of grounding and **shall** be listed by a Nationally Recognized Testing Laboratory (NRTL).
- The EGB **shall** be installed at the point where the antenna transmission lines and other communications cables enter the building or shelter.

- The EGB **shall** be bonded directly to the grounding electrode system using a downward run of 35 mm² csa (#2 AWG) or larger bare, copper conductor. It is recommended to use a larger conductor, such as 120 mm² csa (#4/0 AWG) (United States National Weather Service Manual 30-4106-2005). The grounding conductor **shall** be installed in a direct manner with no sharp bends or narrow loops. See “Bending and Routing Grounding (Earthing), Bonding and Down-Conductors” on page 4-38.
- Flat copper strap may also be used for bonding the EGB to the grounding electrode system and is the preferred method. See Figure 4-37 for an example of copper strap.
- Connection of the grounding electrode conductor to the EGB **shall** use exothermic weld or listed irreversible high-compression connections (ATIS-0600334.2013 section 7.3). Copper strap **shall** connect to the EGB using manufacturer supplied hardware designed for the purpose.

Table 4-7 EXTERNAL GROUND BUS BAR SPECIFICATIONS

Item	Specification
Listing Requirement	Shall be listed by a Nationally Recognized Testing Laboratory (NRTL)
Material	Bare, solid alloy 110 (99.9%) copper bus bar or plate of one piece construction. May be tin-plated.
Minimum Dimensions	Height: 50 mm (2 in.). 100 mm (4 in.) is the recommended minimum height. Thickness: 6.35 mm (0.25 in.) Length: Variable to meet the application requirements and allow for future growth. 305 mm (12 in.) is the recommended minimum length.
Mounting Brackets	Stainless steel
Insulators	Polyester fiberglass 2 kV minimum voltage rating
Conductor Mounting Holes	Number dependent on number of conductors to be attached. Holes should be 11 mm (7/16 in.) on 19 mm (3/4 in.) or 24.5 mm (1 in.) centers for convenient use of two-hole lugs. Slotted hole patterns may be used if properly sized to the minimum dimensions listed previously.
Method of Attachment of Grounding Electrode Conductor	Exothermic welding Irreversible high-compression crimp connection

Ground bus bars should be tinned and secured to the support bracket and structure using theft-deterrent security hardware to help prevent theft. See Figure 4-40.

©Motorola Solutions, Inc. All rights reserved.

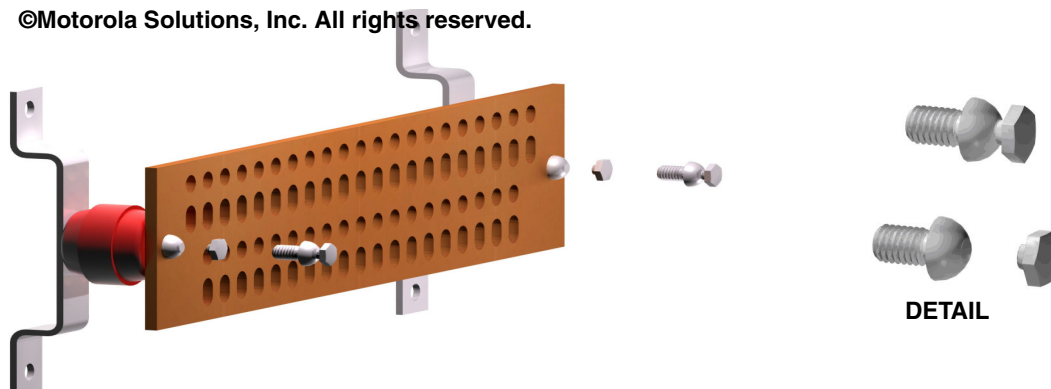

Figure 4-40 Example of Bus Bar Security Hardware

**IMPORTANT**

All transmission lines (including waveguide) and other communications cables with metallic shields (and/or grounding conductor) shall be grounded at their point of entry into the building.

**NOTE**

For improved lightning protection at the site, the RF transmission line entry point and EGB should be installed as low to the ground as practicable; 610 mm (2 ft) is the recommended maximum height for the RF transmission line entry point (see IEEE 1692-2011, section 9.3; United States National Weather Service Manual 30-4106-2005, “Lightning Protection, Grounding, Bonding, Shielding and Surge Protection Requirements”; and TIA-607-B, Figure 18). See “Design Considerations to Help Reduce Effects of Lightning” on page 2-16.

**NOTE**

For reduced impedance to the grounding electrode system, solid copper strap may be used to connect the EGB to the grounding electrode system. Relatively small copper strap has significantly less inductance (impedance to lightning) than large wire conductors. For example, 38.1 mm (1.5 in.) copper strap has less inductance than 70 mm² csa (#2/0 AWG) wire. To further reduce the inductance to ground, several copper straps can be installed across the entire length of the external ground bus bar and routed down to the external ground ring. See Figure 4-41.

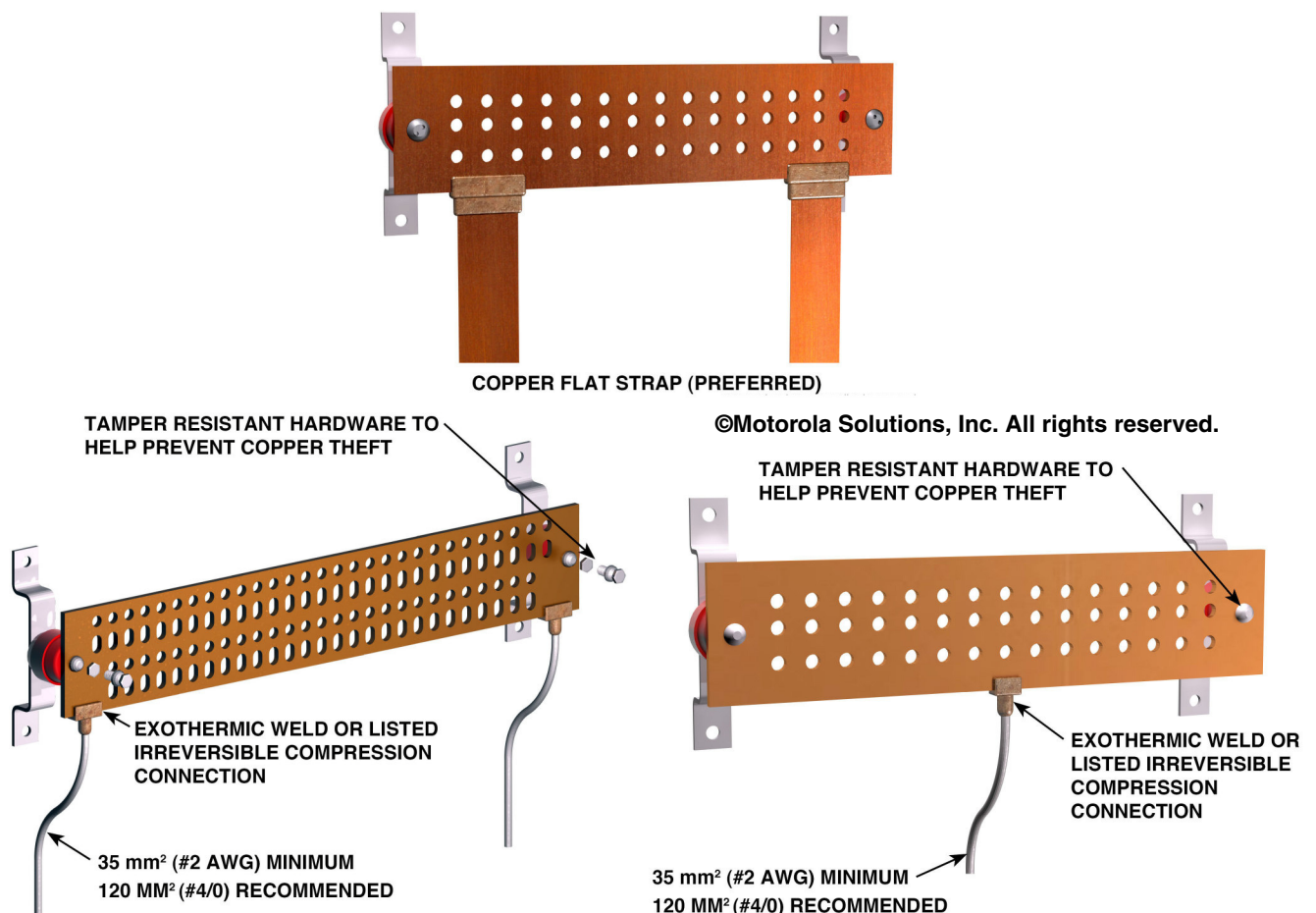

Figure 4-41 Typical External Ground Bus Bars (in Order of Preference)

4.6.4.1 Integrated Panels

Integrated panel kits may be used in place of the EGB (see Figure 4-42). Requirements for integrated panel kits are as follows:

- Integrated panels **shall** be a factory assembly designed for the purpose of grounding.
- Integrated panels **shall** be listed by a Nationally Recognized Testing Laboratory (NRTL).
- Integrated panels **shall** be installed per the manufacture instructions.
- Integrated panels should be sized to accommodate future growth.

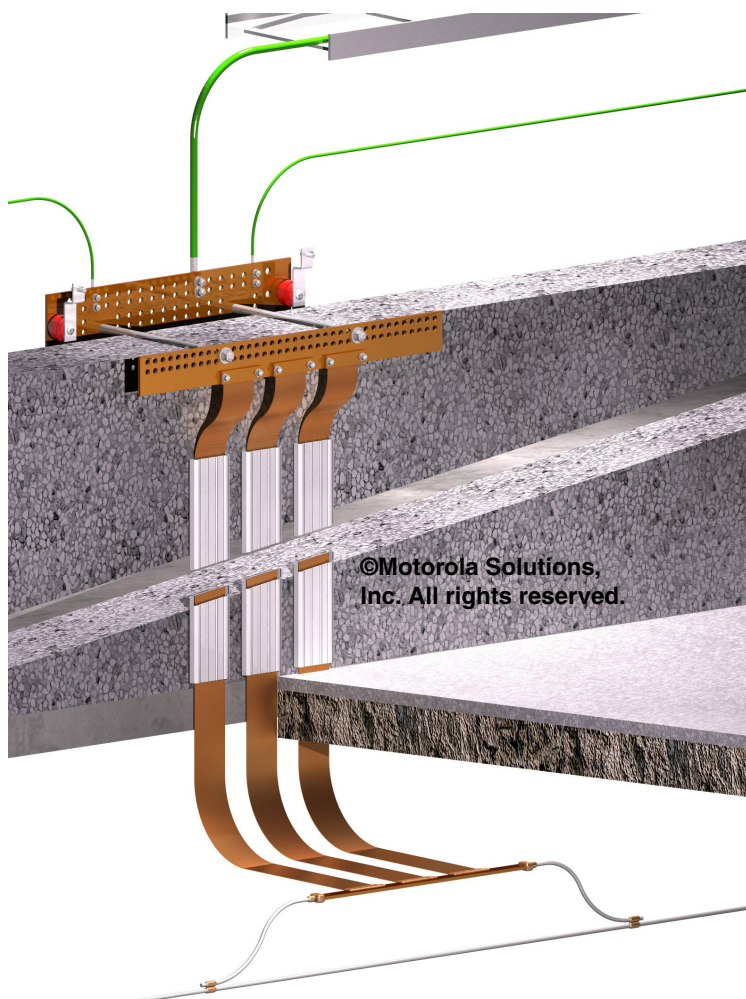

Figure 4-42 Integrated Cable Entry Port With Ground Straps

4.6.5 Tower Ground Bus Bar

Communications cables with an outer metallic shield (for example, coax, waveguide and shielded Category 5e/6/6a, and so on) **shall** be bonded to the tower in order to prevent lightning from creating a difference of potential between the cables and the tower. A difference of potential can cause arcing, resulting in damage to the cables.

The purpose of the Tower Ground Bus bar (TGB) is to provide a convenient termination point on the tower for bonding multiple communications cables (for example, coax, waveguide and shielded Category 5e/6/6a). A TGB may not be required on towers with three or fewer communications cables, if cable bonding can be accomplished in a neat and professional manner.

4.6.5.1 General Requirements for Tower Ground Bus Bars

The general requirements for installing TGB bars are as follows:

- The TGB should be an integral part of the tower construction. If the TGB is not part of the tower construction, it **shall** be constructed and minimally sized according to Table 4-8, ensuring the TGB is large enough to accommodate all transmission lines and other grounding connections.
- The TGB **shall** be designed for the purpose of grounding and **shall** be listed by a Nationally Recognized Testing Laboratory (NRTL).
- Where a galvanized tower is not protected against precipitation run-off from copper and copper alloys, the TGB **shall** be constructed of tinned copper. See “Methods to Help Reduce Corrosion” on page 4-55.
- The TGB **shall** be installed below the communications cable ground kits, to allow for a continuous downward discharge path for lightning.
- Grounding conductors bonded to the TGB **shall** be run as short, straight and smoothly as practicable. See “Bending and Routing Grounding (Earthing), Bonding and Down-Conductors” on page 4-38.
- The TGB grounding electrode conductor may be sleeved in polyvinyl chloride (PVC) tubing for protection if desired (ATIS-0600313.2013, section 11.4). This may be required in order to keep the grounding conductor from making incidental contact with the tower.
- The TGB should be secured using a type of security hardware to help deter theft. See Figure 4-40 for an example.

Table 4-8 TOWER GROUND BUS BAR SPECIFICATIONS

Item	Specification
Listing Requirement	Shall be listed by a Nationally Recognized Testing Laboratory (NRTL)
Material	Bare, solid Alloy 110 (99.9%) copper bus bar or plate of one piece construction. Shall be tin-plated if installing on a galvanized tower. See “Dissimilar Metals and Corrosion Control” on page 4-52 for information regarding tower corrosion related to copper bus bars.
Minimum Dimensions	Height: 50 mm (2 in.). 100 mm (4 in.) is the recommended minimum height. Thickness: 6.35 mm (0.25 in.) Length: Variable to meet the application requirements and allow for future growth. 305 mm (12 in.) is recommended as the minimum length.
Mounting Brackets	Stainless steel
Conductor Mounting Holes	Number dependent on number of conductors to be attached. Holes to be 11 mm (7/16 in.) minimum diameter on 19 mm (3/4 in.) minimum centers for convenient use of two-hole lugs. Slotted hole patterns may be used if properly sized to the minimum dimensions listed previously.
Method of Attachment of Grounding Electrode Conductor	Exothermic welding Irreversible high-compression crimp connection Listed two-hole lugs (intermediate tower ground bus bars only)

4.6.5.2 Bottom Tower Ground Bus Bar Requirements

The requirements for installing the bottom TGB bar are as follows:

- See “General Requirements for Tower Ground Bus Bars” on page 4-47.

- The bottom TGB **shall** be installed below the communications cables ground kits, near the area of the tower at the point where the cables transition from the tower to the shelter. The TGB should be placed at a point where the ground kits may be attached without the need to extend the ground kit conductors.
- The bottom TGB **shall** be bonded directly to the tower using one of the following methods:
 - Bolting the bus bar directly to the tower structure using appropriate stainless steel hardware. This **shall** provide a direct electrical bond. See Figure 4-43.
 - Securing the bus bar to the tower using appropriate mechanical hardware and electrically bonding the bus bar to the tower using a grounding conductor. The grounding conductor **shall** connect to the nearest tower leg or diagonal structural support at a point below the TGB. The grounding conductor **shall** bond to the tower using appropriate hardware, such as stainless steel beam clamps or stainless steel band/strap type clamps.
- The bottom TGB **shall** be connected to the tower grounding electrode system with a 35 mm² csa (#2 AWG) or larger tinned-copper conductor. For reduced impedance to the grounding electrode system, the bottom TGB can be connected to the external grounding electrode system using two grounding electrode conductors (see Figure 4-41 for an example of two grounding electrode conductors).
- The bus bar grounding electrode conductor **shall** attach to the bus bar using exothermic welding or irreversible high-compression connector. Single-hole and two-hole lugs **shall not** be used.



IMPORTANT

The bottom TGB shall be bonded to the tower and to the grounding electrode system. See the following examples for bonding details.

Figure 4-43 shows a bottom bus bar that bonds directly to the tower using appropriate stainless steel hardware. In this type of configuration a bonding conductor from the bus bar to the tower is not required.

Figure 4-44 through Figure 4-48 show some typical installations using bus bars with insulated standoffs. In these configurations a bonding conductor between the bus bar and tower is required.

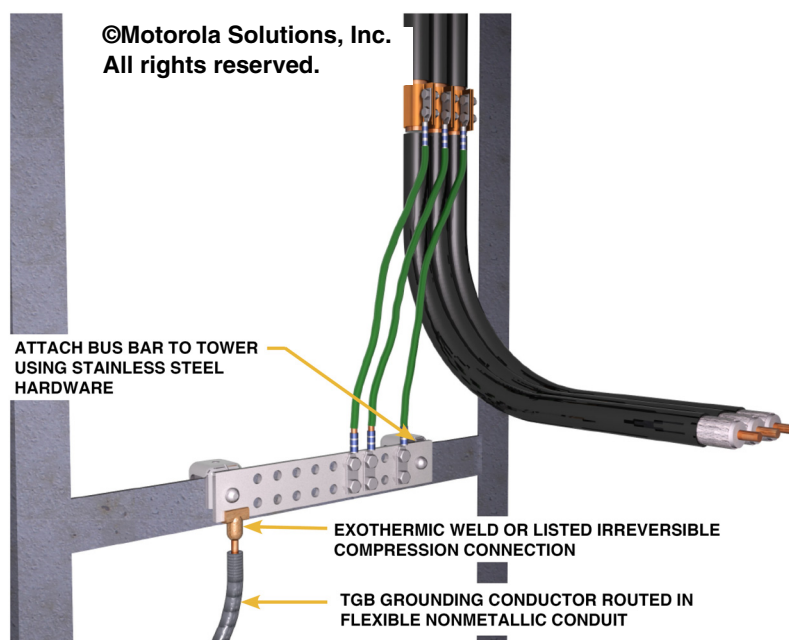

Figure 4-43 Bus Bar Configuration, Bottom Ground Kit on Angular Tower (Weatherproofing Not Shown): Example 1

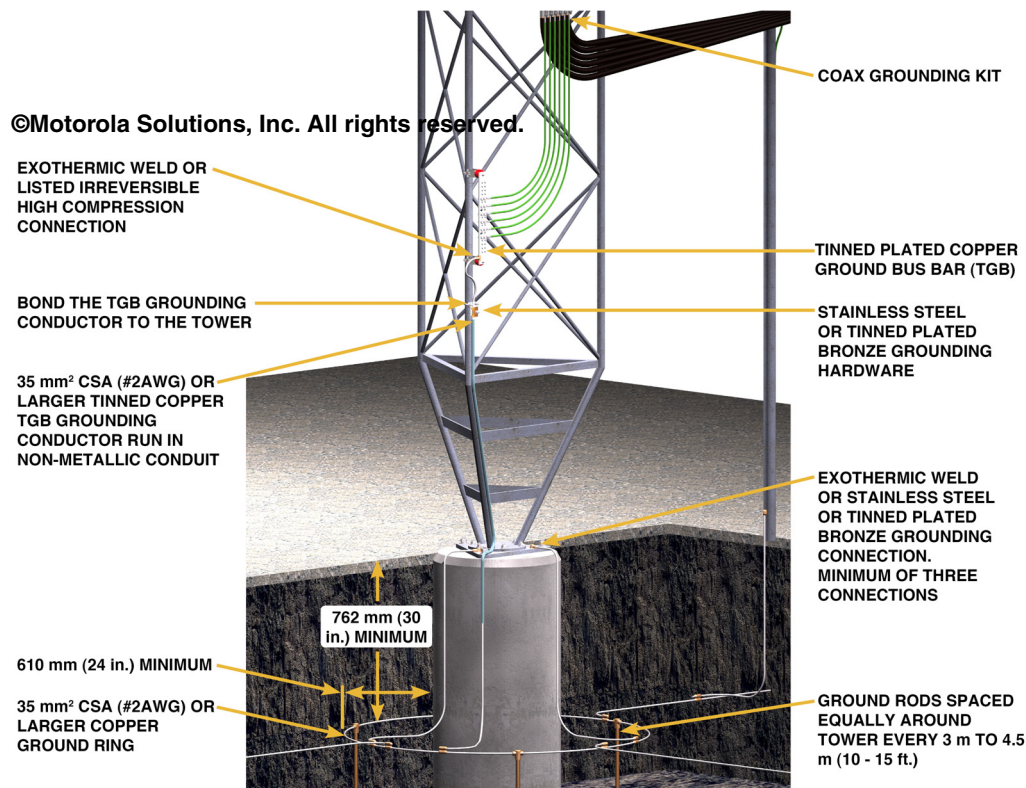

Figure 4-44 Bottom Tower Ground Bus Bar Configuration: Example 2

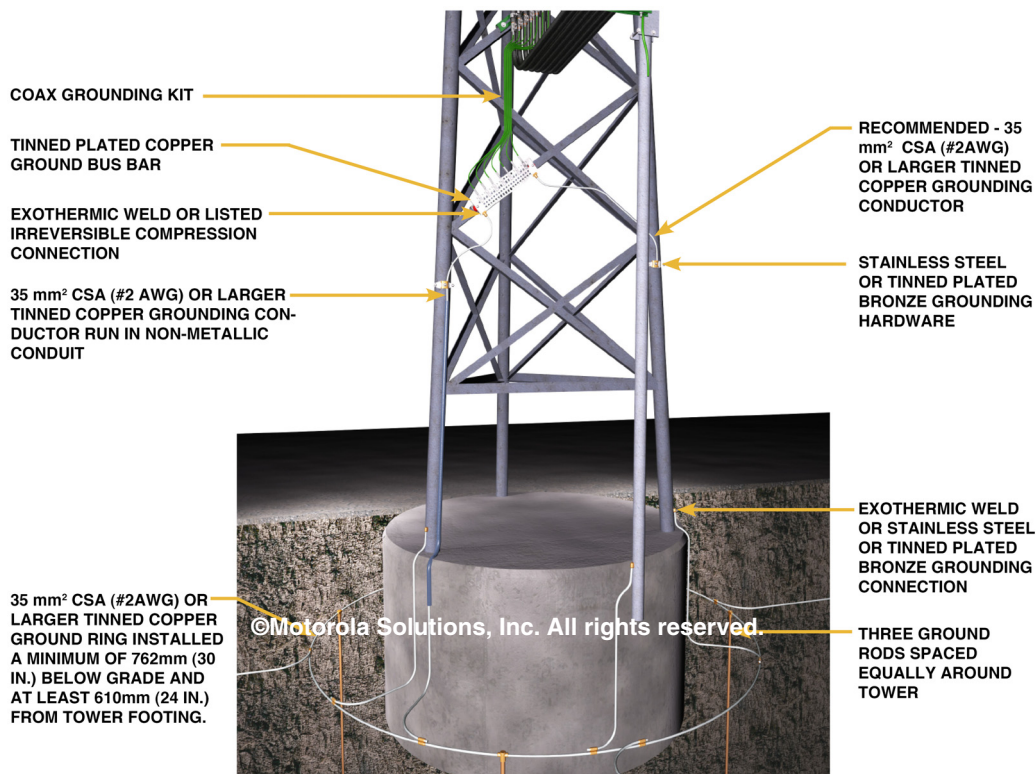

Figure 4-45 Bottom Tower Ground Bus Bar Configuration: Example 3

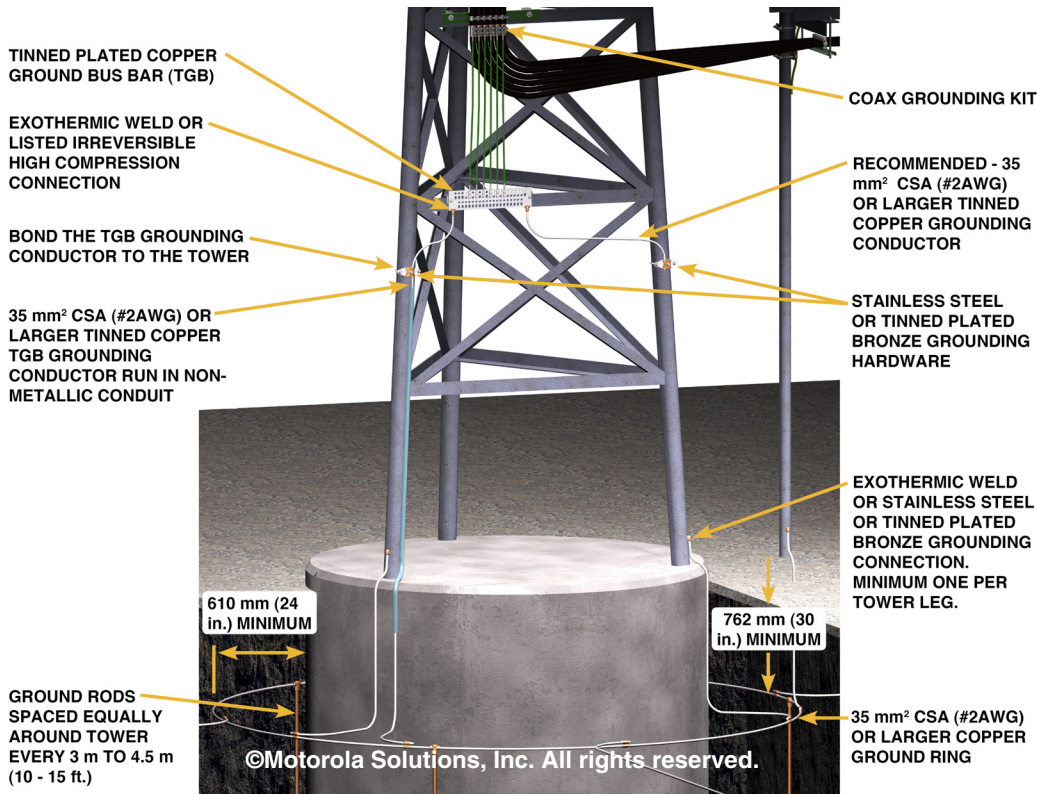

Figure 4-46 Bottom Tower Ground Bus Bar Configuration: Example 4

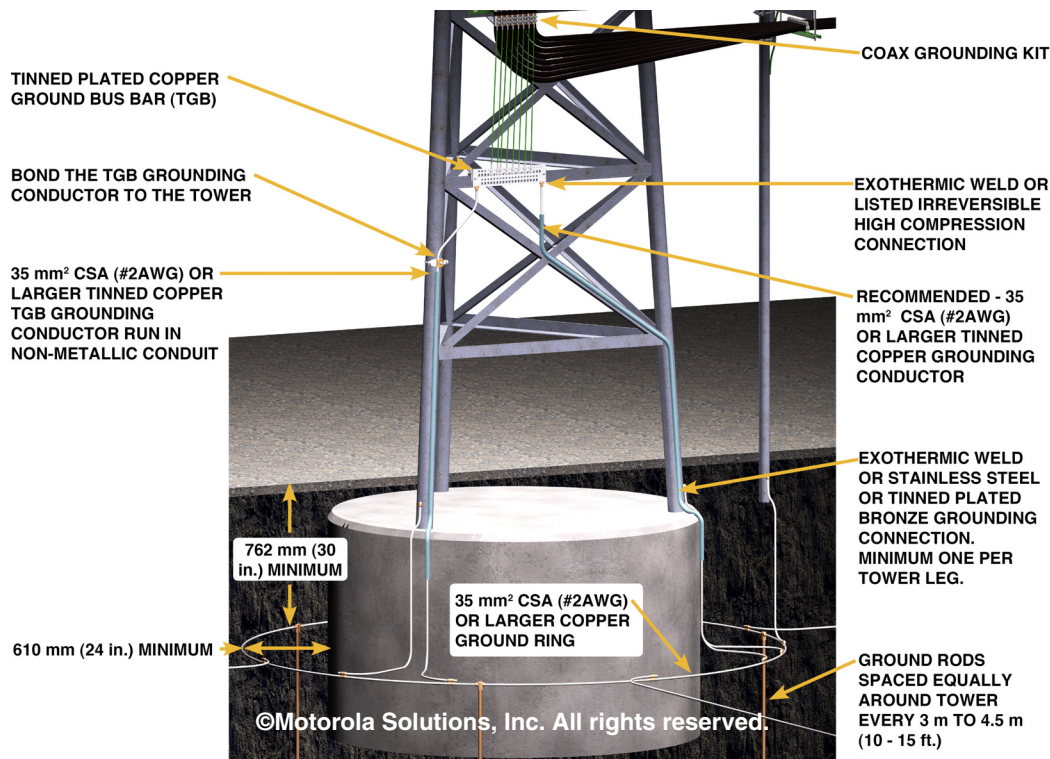

Figure 4-47 Bottom Tower Ground Bus Bar Configuration: Example 5

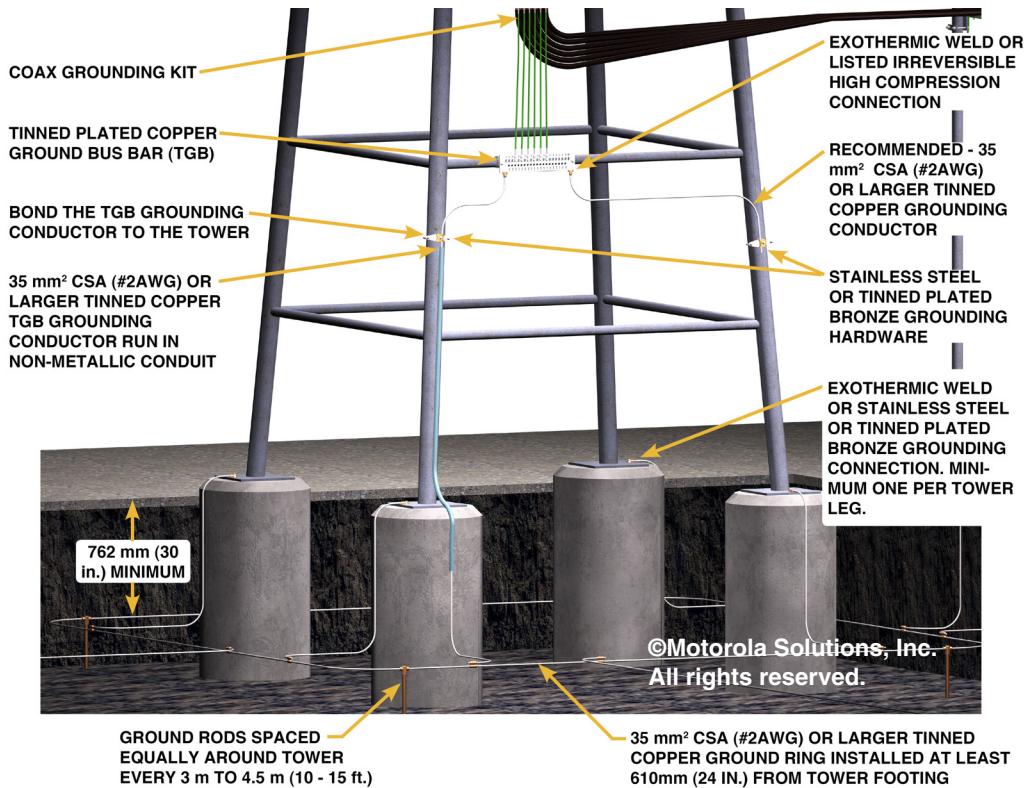

Figure 4-48 Bottom Tower Ground Bus Bar Configuration: Example 6

4.6.5.3 Intermediate Tower Ground Bus Bar Requirements

Additional ground bus bars may be installed at different heights on the tower for bonding multiple communications cables ground kits to the tower, if not already included as part of the tower structure. The requirements for installing intermediate tower ground bus bars (additional bars installed along the vertical length of the tower) are as follows:

- See “General Requirements for Tower Ground Bus Bars” on page 4-47.
- The intermediate TGB **shall** be installed below the communications cable ground kits. The TGB should be placed at a point where the ground kits may be attached without the need to extend the ground kit conductors.
- The intermediate TGB **shall** be bonded directly to the tower using one of the following methods.
 - Bolting the bus bar directly to the tower structure using appropriate stainless steel hardware. This **shall** provide a direct electrical bond. See Figure 4-43 for an example. Note that the grounding electrode conductor would not be required in this application.
 - Securing the bus bar to the tower using appropriate mechanical hardware and electrically bonding the bus bar to the tower using a grounding conductor. The grounding conductor **shall** bond to the tower using appropriate hardware, such as stainless steel beam clamps or stainless steel band/strap type clamps. This conductor should be jacketed or protected in a non-metallic conduit to prevent incidental contact with the galvanized tower structure. See Figure 4-44 through Figure 4-48 for examples. Note that the grounding electrode conductor would not be required in this application.
- Where used, the bus bar grounding electrode conductor **shall** bond to the bus bar using exothermic weld, irreversible compression connectors or listed compression two-hole lugs. Single-hole lugs **shall not** be used.



NOTE

Ground bus bars should be tinned and secured using theft-deterrent security hardware to help prevent theft. See Figure 4-40.

**CAUTION**

Bus bars installed on galvanized towers **shall** be tin-plated to prevent corrosion damage to the galvanized tower. See IEC 62305-3:2010, section E.5.6.2.2.

**CAUTION**

Contact the tower manufacturer for approved exothermic weld locations on the tower when exothermically welding connections.

4.7 Dissimilar Metals and Corrosion Control

Although the types of metal used in a grounding electrode system do not affect the resistance to earth of the grounding electrode system, the metal selected should be resistant to corrosion in the type of soil in which it will be installed. The two aspects to consider regarding the corrosion resistance of a metal are the compatibility with the soil itself, and possible galvanic corrosion effects when it is electrically connected to neighboring metals at the site. See BS 7430:2011, Clause 9.10.3.

4.7.1 Corrosion Related to Soil Type

The compatibility of a metal with soil is determined by the chemical composition of the soil. The chemical composition factors associated with the corrosion of metals in contact with the soil are as follows: acidity or alkalinity (pH), salt content, soil porosity (aeration) and the presence of anaerobic bacteria. See BS 7430:2011, Clause 9.10.1 and TIA/EIA-222-F-R2003.

The following is a list of soil types in order of increasing aggressiveness (BS 7430:2011, Clause 9.10.1):

- Gravelly soils (least aggressive)
- Sandy soils
- Silty soils (loam)
- Clays
- Peat and other organic soils
- Made up soils containing cinders (most aggressive)

The least aggressive soils tend to be those having a high resistivity. The resistivity of soil can be measured, which provides an indication of corrosiveness under aerated conditions (BS 7430:2011, Clause 9.10.1). See “Performing Soil Resistivity Test” on page B-6 for measurement details. Soil with a resistivity below 2,000 ohm centimeters ($\Omega \cdot \text{cm}$) is generally considered to be highly corrosive (TIA/EIA-222-F-R2003).

More details about the aggressiveness of soils can be obtained by measuring the redox (from the words **reduction** and **oxidation**) potential of the soil, which indicates the risk of corrosion due to the presence of anaerobic bacteria (BS 7430:2011, Clause 9.10.1). Test equipment required to measure redox potential is commercially available. The procedure required to test the redox potential can be found in ISO 11271:2002(E) and BS 1377-3. A geotechnical firm may be required to measure the redox potential of the soil.

General guidance on the corrosiveness of some grounding electrode system metals in relation to soil composition is given in Table 4-9 (BS 7430:2011, Table 9). A geotechnical firm may be required to determine all of the listed soil parameters.

The following general observations can be made from Table 4-9:

- Stainless steel ground rods are compatible with most soil types.
- Copper-clad steel or solid copper ground rods are one of the better and commonly used materials for grounding electrodes. However, the adverse effect of dissolved salts, organic acids and acid soils generally should be noted (BS 7430:2011, Clause 9.10.1).

- Copper or copper-clad ground rods should not be used in soils where organic acids are present, unless protective measures are taken, such as encasing the ground rods in a grounding electrode encasement material. Organic acids are commonly found in poorly drained and poorly aerated soils. See “Grounding (Earthing) Electrode Encasement Materials” on page 4-35.
- Galvanized ground rods should not be used in soils with a redox potential below 200mV.
- Protective measures should be taken in soils with dissolved salts or chlorides, such as encasing all grounding electrode system components in a grounding electrode encasement material. See “Grounding (Earthing) Electrode Encasement Materials” on page 4-35.
- Galvanized ground rods should not be used in acidic soils with a pH below 6.

Table 4-9 CORROSION RESISTANCE PROPERTIES OF COMMON GROUNDING ELECTRODE SYSTEM METALS AS RELATED TO SOIL COMPOSITION

Soil Parameter		Grounding Electrode Metal		
		Copper	Galvanized Steel	Austenitic Stainless Steel*
Resistivity ($\Omega\cdot\text{cm}$)	< 700	Slightly Reduced	Moderately Reduced	Slightly Reduced
	700 to 4000	Slightly Reduced	Moderately Reduced	Generally Unaffected
	> 4000	Generally Unaffected	Generally Unaffected	Generally Unaffected
Redox Potential (mV)	< 200	Moderately Reduced	Considerably Reduced	Moderately Reduced
	200 to 400	Slightly Reduced	Slightly Reduced	Generally Unaffected
	> 400	Generally Unaffected	Generally Unaffected	Generally Unaffected
Moisture Content (%)	< 10	Generally Unaffected	Generally Unaffected	Generally Unaffected
	10 to 80	Slightly Reduced	Moderately Reduced	Slightly Reduced
	> 80	Slightly Reduced	Slightly Reduced	Slightly Reduced
Dissolved				
Salts		Moderately Reduced	Moderately Reduced	Slightly Reduced
Chlorides		Moderately Reduced	Moderately Reduced	Slightly Reduced
pH				
Acidic	< 6	Moderately Reduced	Considerably Reduced	Slightly Reduced
Neutral	6 to 8	Generally Unaffected	Generally Unaffected	Generally Unaffected
Alkaline	> 8	Slightly Reduced	Moderately Reduced	Generally Unaffected
Organic Acids	> 8	Considerably Reduced	Moderately Reduced	Slightly Reduced
* Austenitic stainless steel shall be formed from 18% chromium and 8% nickel (18/8 stainless steel), per CSA C222.2 No. 41-07/UL 467-2007, section 6.9.2.8. Table based on information from BS 7430:2011, Table 9.				

4.7.2 Galvanic Corrosion

Galvanic corrosion (also called dissimilar metals corrosion) refers to corrosion damage induced when two dissimilar metals are electrically connected and coupled through an electrolyte (such as soil). When a metal is electrically connected to a dissimilar metal, a difference of potential exists between the two metals. If the dissimilar metals are also in contact with a low resistivity soil, a complete circuit exists. Current will flow from one metal to the other due to the electrical connection and return path through the soil. This is the same naturally-occurring phenomenon that allows a battery to provide current flow when its terminals are electrically connected to a load (TIA/EIA-222-F-R2003, ANNEX J). See Figure 4-49 for an example of installations with and without galvanic corrosion.

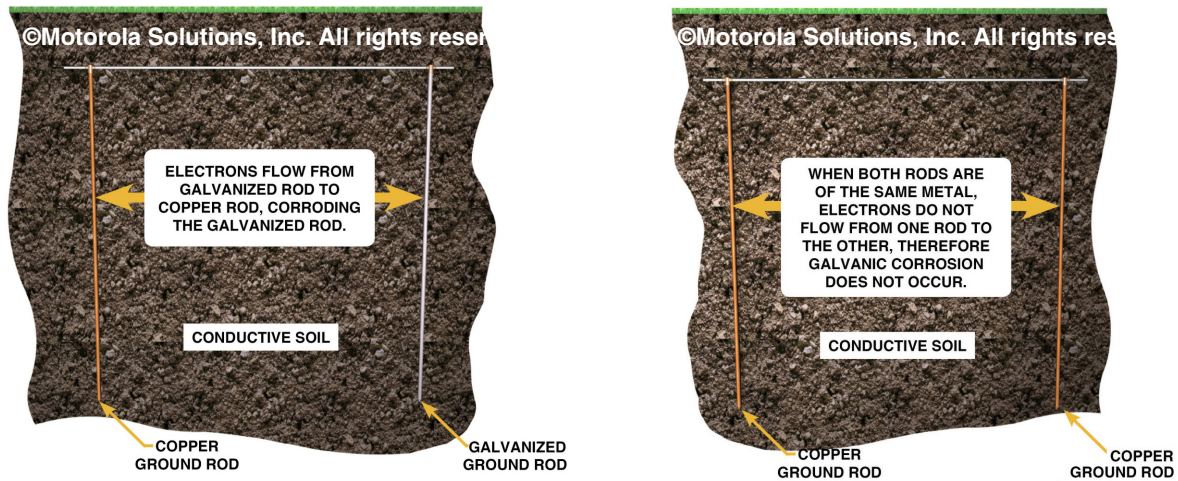

Figure 4-49 Installations With and Without Galvanic Corrosion

Metals may be listed in order of their respective potentials; such a list is called a galvanic series. A galvanic series of commonly used grounding electrode system metals and alloys is given in Table 4-10. When a complete circuit exists, corrosion occurs on the metal listed higher in the galvanic series, the anode, which is where current exits and travels through the soil toward the metal listed lower on the galvanic series (cathode). For example, if a large copper grounding electrode system in a conductive soil is directly or indirectly (through guys) electrically connected to a steel anchor, corrosion will occur on the anchor, because steel is listed higher in the galvanic series than copper. See ANSI/TIA/EIA-222-F-R2003, Annex J.

Table 4-10 GALVANIC SERIES OF COMMON METALS

Metal	
Magnesium	
Zinc (material used to galvanize steel)	
Aluminum	
Steel, Iron	
Lead, Tin	
Brass, Copper, Bronze	
Silver	
Graphite	Noble End or Cathodic End
Source: TIA/EIA-222-F and MIL-HDBK-419A	

The rate of corrosion is primarily dependent on the conductivity of the soil and the relative position of the metals in the galvanic series. The higher the soil conductivity (low resistivity) and the further apart the metals in the galvanic series, the faster the rate of corrosion (TIA/EIA-222-F-R2003). To some extent, the rate of corrosion also depends on the relative surface areas of the metals (BS 7430:2011, Clause 9.10.2, and IEEE 142-2007). A small anode (such as a galvanized steel guy anchor point) and large cathode (such as a copper grounding electrode system) should not be installed; in this case, the total current is confined to a small space and the current density is large, resulting in corrosion of the galvanized steel (IEEE 142-2007).

4.7.3 Miscellaneous General Information

This section contains miscellaneous guidelines to help prevent corrosion of the grounding electrode system and other metallic items at the communications site:

- Galvanized steel is strongly electronegative to copper and steel encased in concrete, therefore, careful consideration **shall** be given before galvanized ground rods are used at a site with a concreted-encased electrode. Copper, copper-clad steel or stainless steel rods should be used near concrete-encased electrodes to help prevent corrosion. See BS 7430:2011, clause 9.10.1 and IEC 62305-3:2010, section E.5.6.2.2.2, for additional information.
- Steel encased in concrete has a potential similar to that of copper; therefore, it may be bonded to copper or copper-clad ground rods. See BS 7430:2011, Clause 9.10.1, and IEEE 142-2007 for additional information.

4.7.3.1 Installation of Grounding Electrode System in Corrosive Soils

Careful consideration **shall** be given when installing a grounding electrode system in soils with corrosive elements. Such areas include the volcanic soils in Alaska and Hawaii. In these and similar areas, it is recommended to install supplemental cathodic protection for the grounding electrode system.

Such cathodic protection may be applied as follows (see FAA-STD-019e, section 4.2.4.3.6, and NWSM 30-4106-2005, section 2.8.2.6):

- A buried steel plate (acting as a sacrificial anode) is bonded to the grounding electrode system using a 120 mm² csa (#4/0 AWG) stranded bare copper conductor. The 120 mm² csa (#4/0) AWG conductor **shall** be exothermically welded to the grounding electrode system and to the sacrificial plate. The conductor **shall** be welded to the center of the plate, not near the edge or corners. The minimum size of the sacrificial plate **shall** be 10.16 cm x 10.16 cm (4 in. x 4 in.) and 12.7 mm (0.5 in.) thick. This sacrificial plate is in addition to any other required grounding electrodes at the site.
- The sacrificial plate **shall** be installed in the same general manner as described in “Ground Plate Electrodes” on page 4-21. Coke breeze should be used as the backfill material.
- Assistance from Motorola Solutions Engineering or other engineering firm is recommend in these cases. See NWSM 30-4106-2005, section 2.8.2.6, for more information.

4.7.4 Methods to Help Reduce Corrosion

This section contains some general requirements and guidelines to help prevent corrosion of the grounding electrode system and other metallic items at the communications site:

- Select appropriate grounding electrode system components using Table 4-9.
- Tinned-copper conductors should be used when bonding to tower legs and other galvanized steel items. See ATIS-0600313.2013, section 10.7.
- Tinned-copper conductors **shall** be used when bonding to tower legs and other galvanized steel items with mechanical clamps (IEC 62305-3:2010, section E.5.6.2.2.1).
- Galvanic corrosion should be considered when installing a grounding electrode system in close proximity to steel towers, steel poles or lead-sheathed cables, because copper grounding electrode system components may accelerate the rate of corrosion on these items. In these instances, tinned-copper conductors and stainless steel ground rods may be an option.
- Galvanized ground rods should be avoided where concrete-encased electrodes are used at the site (IEC 62305-3:2010, section E.5.6.2.2.1). In these instances copper, copper-clad or stainless steel rods should be used (IEC 62305-3:2010, section E.5.6.2.2.2).

- Where tinned conductors or galvanized ground rods are used, care **shall** be exercised during installation so that surfaces are not damaged. If surfaces of these ground elements are damaged, the potential for deterioration from galvanic action increases (ATIS-0600313.2013, section 11.5, and ATIS-0600334.2013, section 13.6).
- Aluminum or copper-clad aluminum grounding conductors **shall not** be used (NFPA 70-2017, Article 250.64), unless otherwise allowed (such as in the above-ground portions of a lightning protection system).
- Copper **shall not** come into incidental contact with galvanized steel.
- Bare copper and tinned-copper conductors **shall not** be secured directly to metallic structures. The conductors **shall** be installed in a non-metallic conduit (or other methods) to prevent incidental contact with the structure.
- Copper **shall not** come into incidental contact with aluminum.
- Precipitation run-off from copper and copper alloys can attack galvanized parts (BS 6651:1999 and IEC 62305-3:2010, section E.5.6.2.2); therefore, bare copper conductors or copper bus bars **shall not** be installed above galvanized steel, such as a tower, unless the steel is protected against the precipitation run-off (IEC 62305-3:2010, section E.5.6.2.2).

**CAUTION**

Copper parts shed extremely fine particles, which may cause severe corrosive damage to galvanized parts, even where the copper and galvanized parts are not in direct contact (IEC 62305-3:2010, section E.5.6.2.2).

- Where a galvanized tower is not protected against precipitation run-off from copper or copper alloy bus bars, the Tower Ground Bus bar (TGB) **shall** be constructed of tinned-copper.
- Exothermically welded joints on galvanized material **shall** be thoroughly cleaned and coated with an approved corrosion inhibitor (such as a zinc-enriched paint).
- Copper/aluminum joints **shall** be avoided where practicable. In cases where they cannot be avoided, the connections **shall** be made using an AL/CU listed bimetallic transition connector (IEC 62305-3:2010, section E.5.6.2.2.1). Tinned-copper conductors should be used in these situations.
- Use a listed conductive anti-oxidant compound on all mechanical connections (ATIS-0600334.2013, section 9). The anti-oxidant compound **shall** be liberally installed between the two metals. See “Anti-Oxidant Compound” on page 4-63.
- Where soil conditions are not favorable, such as highly acidic or alkaline, grounding electrode system component corrosion may be reduced by encasing the components in a grounding electrode encasement material. See “Grounding (Earthing) Electrode Encasement Materials” on page 4-35.
- Where soil conditions are not favorable, such as soils that contain dissolved salts or chlorides, grounding electrode system component corrosion may be reduced by encasing the components in a grounding electrode encasement material. See “Grounding (Earthing) Electrode Encasement Materials” on page 4-35.
- Where soil conditions are not favorable, such as highly acidic or alkaline, grounding electrode system component corrosion may be reduced by installing electrolytic ground rods encased in a grounding electrode encasement material. See “Grounding (Earthing) Electrode Encasement Materials” on page 4-35 and “Electrolytic Ground Rods” on page 4-19.
- Where soil conditions are not favorable, such as highly acidic or alkaline, the useful life of a grounding electrode system can be extended by using solid copper ground rods instead of copper-clad rods, if soil conditions allow driving of the solid copper rod.
- Where soil conditions are not favorable, such as highly acidic or alkaline, the useful life of buried grounding conductors can be extended by using larger conductors, such as 70 mm² csa (#2/0 AWG) instead of 35 mm² csa (#2 AWG). Grounding conductors larger than 35mm² csa (#2 AWG) may be stranded, but should be tinned to help reduce corrosion.
- See “Guyed Towers” on page 4-83 for information regarding proper grounding techniques to help minimize galvanic corrosion of the guy anchor.

4.8 Bonding to the External Grounding and Bonding System

Proper bonding and connection techniques are critical for an effective external grounding and bonding system. Bonding **shall** be performed so that a suitable and reliable connection exists. The following subsections describe external grounding, bonding and connection requirements.

4.8.1 General Requirements for Bonding to External Grounding

The following are the general requirements for external grounding system bonding and connections:

- Below-grade grounding electrode system connections **shall** be joined using exothermic welding or listed irreversible high-compression fittings (ATIS-0600313.2013, Figure 3(a) and IEEE 1692-2011, section 8.2).
- Above-grade grounding electrode system connections (such as grounding electrode conductor connection to ground bus bars or tower legs) **shall** be joined using exothermic welding or listed irreversible high-compression fittings, unless allowed otherwise in this chapter. (ATIS-0600313.2013, Figure 3(a)).
- Above-grade bonding connections (such as bonding to ancillary equipment or bonding coaxial ground kits) **shall** be joined using exothermic welding, listed irreversible high-compression fittings, listed irreversible compression lugs or listed clamping devices.
- Exothermic welds and irreversible high-compression connections **shall** have a maximum DC resistance of one milliohm when measured between the bonded components with a 4-terminal milliohm/micro-ohm meter (FAA-STD-019e, sections 4.1.1.1 and 4.2.4.3.9; MIL-HDBK-419A Volume I, section 7.3; and NWSM 30-4106, section 2.8.5).
- Irreversible high-compression fittings, irreversible compression lugs and other types of mechanical clamping devices **shall** be listed for the purpose, for the type of conductor and for the size and number of conductors used.
- Connection devices **shall** be constructed from appropriate metal(s) so as to not react with the metals being bonded. See “Dissimilar Metals and Corrosion Control” on page 4-52.
- Paint, enamel, lacquer and other nonconductive coatings **shall** be removed from threads and surface areas where connections are made to ensure good electrical continuity (NFPA 70-2017, Article 250.12). Use of a star washer does not alleviate the requirement to remove nonconductive coatings from attachment surfaces. See Figure 4-50 and Figure 4-51 for proper star/lock washer location. Star washers should only be used as a lock washer.

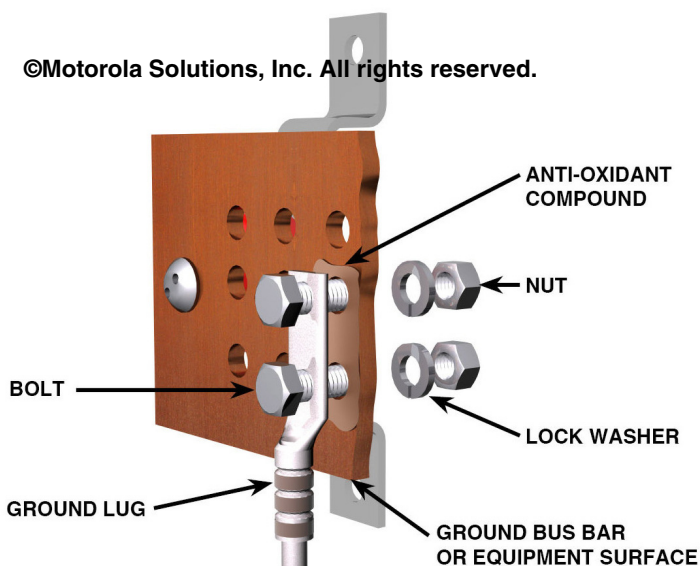
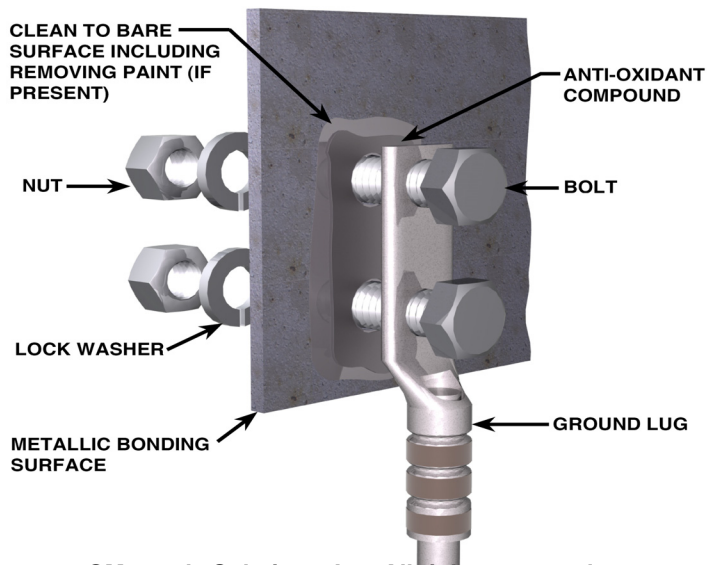

Figure 4-50 Proper Bonding to Bus Bars



©Motorola Solutions, Inc. All rights reserved.

Figure 4-51 Proper Bonding of Ancillary Support Equipment

- Bonding surfaces **shall** be cleaned to remove dirt, corrosion and oxidized material in the connection surface area (ATIS-0600334.2013, section 9).
- Mechanical joints **shall** be protected with a listed conductive anti-oxidation compound (ATIS-0600334.2013, section 9). Excess anti-oxidant compound **shall** be removed after completion of the bonding connection. See “Anti-Oxidant Compound” on page 4-63.
- After bonding to a painted or galvanized steel structure, the area **shall** be thoroughly cleaned and coated with an approved corrosion inhibitor (such as a zinc-enriched paint).
- Exothermic welding is the preferred method for establishing bonding connections to the external grounding electrode system.



IMPORTANT

Exothermic welding or listed irreversible high-compression fittings are the only acceptable methods for below-grade bonding. Other mechanical connection methods shall not be used below grade.

4.8.2 Above-Grade Mechanical Lugs and Connection Devices

Mechanical bonding connections are typically accomplished using listed single-hole lugs, listed two-hole lugs or listed clamps.

Mechanical bonding requirements are as follows:

- Lugs and connection devices **shall** be listed by a Nationally Recognized Testing Laboratory (NRTL), such as CSA or UL (reference documents CSA C22.2 NO. 41-07 and UL 467-2007).
- Lugs and connection devices **shall** be listed for the purpose, for the type of conductor and for the size and number of conductors used. See Figure 4-53 for an example of a lug with listed markings.
- Lugs and connection devices used on solid conductors **shall** be listed for use on solid conductors. See product documentation for listing details.
- Lugs used **shall** be designed for 0.64 cm (0.25 in.) minimum fastening hardware, where practicable.
- Lugs and connection devices **shall** be constructed from tinned-copper, tinned-copper alloy or stainless steel.
- Connection devices used as part of lightning protection systems **shall** be listed for the purpose.

- Lug attachment to conductors **shall** be by exothermic weld or irreversible compression connection. See Figure 4-52 for examples of exothermic weld connections and Figure 4-53 for an example of an irreversible compression connection.

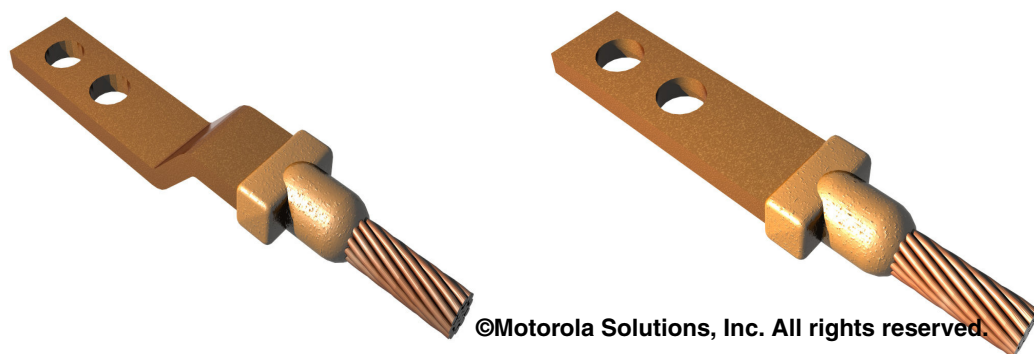

Figure 4-52 Lugs Exothermically Welded to Conductor



NOTE

In this standard, a 2 ton connection is considered irreversible compression; a 12 ton connection is considered irreversible high-compression.



NOTE

A tonne is also known as a metric ton.

- Irreversible compression lugs and fittings **shall** be capable of being crimped to a minimum of 1.81437 tonne (2 tons) of force.
- Irreversible compression lugs and fittings **shall** be crimped to the conductor with a minimum of 1.81437 tonne (2 tons) of force.
- Two-hole long barrel lugs are preferred over single-hole lugs and should be used where practicable. Two-hole lugs prevent movement of the lug.



IMPORTANT

Where aluminum lightning protection system conductors are used, appropriately listed connection devices shall be used.



IMPORTANT

Setscrew-style lugs are not permitted anywhere in the external grounding and bonding system.

Figure 4-53 illustrates the typical irreversible compression crimping process for a lug. Refer to the lug and/or compression tool manufacturer for specific instructions.



STEP 1:
Choose a lug appropriate for the application and conductor size.



STEP 2:
Strip conductor jacket to appropriate length for the lug.



STEP 3:
Verify conductor fits properly into lug. There should be no exposed conductor between the lug and the conductor jacket. The conductor should reach the inspection hole.



STEP 4:
Apply appropriate anti-oxidant compound inside lug.



STEP 5:
Apply appropriate anti-oxidant compound to conductor.

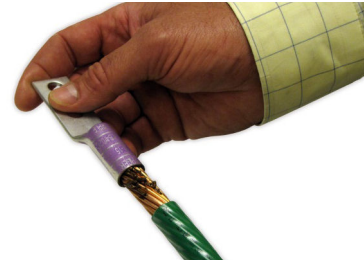

STEP 6:
Insert conductor into lug.



STEP 7:
Position the lug so it makes contact with the conductor jacket.



STEP 8:
Crimp long barrel lugs in at least two locations: place the first crimp adjacent to inspection window. Place the second crimp adjacent to the conductor jacket.

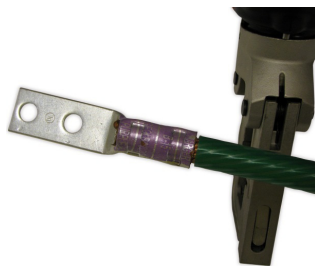

STEP 9:
Remove excess anti-oxidant compound from the lug and conductor jacket. Connection is complete.

©Motorola Solutions, Inc. All rights reserved.

Figure 4-53 Irreversible Compression Connector and Typical Crimping Tool

Table 4-11 lists the color code for typical irreversible compression lugs. Refer to the specific compression lug documentation for details.

Table 4-11 TYPICAL IRREVERSIBLE COMPRESSION LUG COLOR CODE

Conductor Size	Lug Color Code
# 6 AWG	Blue
# 6 AWG Solid	Red
# 4 AWG	Gray
# 2 AWG	Brown
# 2 AWG Solid	White
# 1 AWG	Green
# 1/0 AWG	Pink
# 2/0 AWG	Black
# 3/0 AWG	Orange
# 4/0 AWG	Purple
250 kcmil	Yellow
500 kcmil	Brown
750 kcmil	Black

4.8.3 Securing Hardware

Securing hardware are the fasteners (for example, bolts, nuts, screws and washers) used to attach a ground lug or clamping device to a bus bar or a metallic object. Minimum requirements for securing hardware are as follows:

- All securing hardware **shall** be constructed from 300 series stainless steel (FAA-STD-019e, section 4.1.1.2.4.2), unless otherwise specified or permitted.



NOTE

300 series stainless steel is commonly identified as 18-8.

- Type 316 stainless steel is recommended for corrosive environments (such as salt water environments).
- The bolts or screws **shall** be sized appropriately to match the lug size. The recommended minimum diameter bolt size is 6.35 mm (0.25 in.).
- Securing hardware **shall** be sufficiently torqued to ensure a reliable bond while not over compressing the lock washer.



IMPORTANT

Careful attention must be given when selecting hardware pieces to ensure no other metal types are inadvertently used. Mixing other metal types with the stainless steel can cause severe corrosion, resulting in an ineffective electrical bond and a potential RF interference point.



NOTE

300 series stainless steel has very little attraction to a magnet, whereas 400 series stainless steel does.

4.8.4 Above-Grade Mechanical Bonding Requirements

Above-grade bonding connections to communication system devices, ancillary equipment or bus bars typically require the use of mechanical lugs or clamps bonded to the grounding conductor and attached to the equipment being bonded. See Figure 4-51 for bonding examples. Requirements for above-grade mechanical bonding are as follows:

- Lugs and clamps **shall** meet the requirements of “Above-Grade Mechanical Lugs and Connection Devices” on page 4-58.
- Paint, enamel, lacquer and other nonconductive coatings **shall** be removed from threads and surface areas where connections are made to ensure good electrical continuity (NFPA 70-2017, Article 250.12). Use of a star washer does not alleviate the requirement to remove nonconductive coatings from attachment surfaces. See Figure 4-50 for proper star/lock washer location. Star washers should only be used as a lock washer.
- Bonding surfaces **shall** be cleaned to remove dirt, corrosion and oxidized material in the connection surface area (ATIS-0600334.2013, section 9).
- All mechanical joints **shall** be protected with a listed conductive anti-oxidation compound (ATIS-0600334.2013, section 9). See “Anti-Oxidant Compound” on page 4-63 for anti-oxidant compound requirements.
- After bonding to a painted or galvanized steel structure, the area **shall** be thoroughly cleaned and coated with an approved corrosion inhibitor (such as a zinc-enriched paint).
- Two-hole long barrel lugs are preferred over single-hole lugs and should be used where practicable. Two-hole lugs prevent movement of the lug.
- Where two-hole lugs are used, securing hardware **shall** be used in both holes.
- Lugs **shall** be secured to the surface using a combination of nut, bolt and lock washer when both sides of the bonding surface are accessible (see Figure 4-51).
- Bolts **shall** be tightened sufficiently to maintain the contact pressures required for effective bonding, but **shall not** be over-tightened to the extent that deformation of bond members occurs (FAA-STD-019e, section 4.1.1.2.4.2).
- When connecting ground lugs or compression terminals to ancillary equipment, such as air conditioners and vent hoods, a lock washer **shall** be placed on the nut side. See Figure 4-51 for an example.

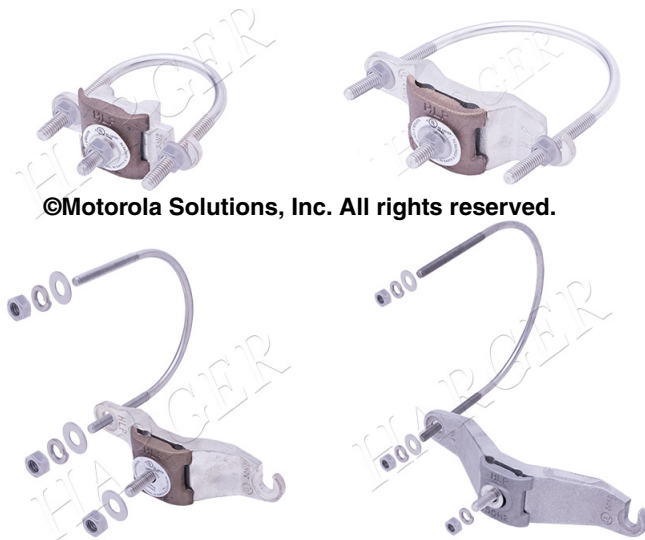

Figure 4-54 Examples of Pipe Bonding Clamps

4.8.5 Bonding Objects in Blind Locations

Bonding locations where the rear of the object being bonded is inaccessible for installation of a nut are commonly known as blind locations. Common examples of blind locations are door frames, metallic siding and vent covers.

Follow all requirements in “Bonding to the External Grounding and Bonding System” on page 4-57 and all subsections. Two-hole lugs **shall** be used where practicable. A lock washer **shall** be installed between the lug and the bolt/screw head.

The following methods may be used where the metallic object to be bonded is thick enough to engage at least two threads from the fastener:

- Drill and tap the appropriate size hole(s) in the object for the size fastener being used. Attach the ground lug using stainless steel hardware.
- Drill the appropriate size hole(s) in the object for the size fastener being used. Attach the ground lug using stainless steel thread-forming machine screw(s).



NOTE

A typical thread-forming machine screw used in this application has approximately 32 threads per inch.

The following methods may be used when the metallic object is not thick enough to engage at least two threads from the fastener:

- Attach the ground lug using an existing screw already present for securing the metallic object. If practicable, a two-hole lug **shall** be used. When a two-hole lug is used, secure the second hole using one of the following additional options.
- Attach the ground lug using appropriate stainless steel screw(s) that penetrates to wood or metal framing.
- Drill an appropriately sized hole and install an internally threaded rivet. Attach the ground lug using stainless steel hardware.
- Punch a small hole in the metal using an awl. Attach the ground lug using stainless steel thread-forming machine screw(s). The practice of punching a hole with an awl may help create more surface area for thread contact.
- In some applications the use of stainless steel sheet metal screws may be the only available option to bond some items (such as metallic siding). Sheet metal screws **shall** only be used where no other option is available. A suggested best practice is to first punch a small hole in the metal using an awl.

Attaching a stainless steel threaded stud to the metallic object using capacitive discharge welding may also be an option. The threaded stud provides an attachment point for a ground lug. See the capacitive discharge welding tool documentation for specific welding requirements.

4.8.6 Anti-Oxidant Compound

Anti-oxidant compound is used on mechanical bonds to help prevent oxidation and ensure a good electrical connection. All mechanical joints **shall** be protected by a listed conductive anti-oxidant compound (ATIS-0600334.2013, section 9).

Requirements for anti-oxidant compounds are as follows:

- The anti-oxidant compound **shall** be the conductive type and **shall** be designed for use in electrical connections.
- The anti-oxidant compound **shall** be listed by a Nationally Recognized Testing Laboratory (NRTL).
- The anti-oxidant compound **shall** be listed for the type(s) of metal it is applied on.
- The anti-oxidant compound **shall** be used according to the manufacturer instructions.
- See Table 4-12 for suggested anti-oxidant compounds for each combination of connection device and bonding surface:
 - Zinc anti-oxidant compound (typically gray colored) should be applied between galvanized steel, steel or aluminum bonding surfaces and stainless steel or tin-plated connection devices.
 - Zinc anti-oxidant compound (typically gray colored) should be applied between tin-plated bus bars and tin-plated lugs.
 - Copper anti-oxidant compound (typically copper colored) should be used between copper, bronze or brass bonding surfaces and copper, copper alloy or tin-plated connection devices.

- Copper anti-oxidant compound (typically copper colored) should be used between copper bus bars and tin-plated lugs.
- Copper anti-oxidant compound should be used between copper or copper alloy bonding surfaces and stainless steel lugs.
- Copper or zinc anti-oxidant compound may be used between tin-plated bonding surfaces and stainless steel lugs.

Table 4-12 ANTI-OXIDANT COMPOUND MATRIX - CONNECTION DEVICE VERSUS BONDING SURFACE

Connection Devices	Bonding Surfaces				
	Copper or copper alloys (such as bronze and brass)	Tin-plated	Steel	Galvanized steel	Aluminum
Copper or copper alloys	Copper	Copper	Copper or copper alloys are not approved as connection devices to steel, galvanized steel or aluminum bonding surfaces. Tin-plated or stainless steel connection devices are required.		
Tin-plated	Copper	Gray/Zinc	Gray/Zinc	Gray/Zinc	Gray/Zinc
Stainless steel	Copper	Copper or Gray/Zinc	Gray/Zinc	Gray/Zinc	Gray/Zinc

NOTE: See anti-oxidant compound manufacturer instructions.

4.8.7 Below-Grade Connections

The following subsections describe acceptable below-grade bonding methods. Exothermic welding and listed irreversible high-compression fittings are the only acceptable methods for below-grade bonding. Other types of mechanical connection methods **shall not** be used below-grade (see ATIS-0600313.2013, Figure 3(a)).



IMPORTANT

In some instances, exothermic welding may not be possible due to safety concerns (such as at chemical or petroleum plants) and/or site specific conditions (such as a high water table). In these cases, listed irreversible high-compression connections shall be used.

4.8.7.1 Exothermic Welding

Exothermic welding is a method of welding electrical connections without an external heat source, such as electricity or gas. The process is based on the reaction of granular metals which when combined, produce a molten metal. This reaction, which is completed in seconds, takes place in a graphite crucible. The liquid metal flows from the crucible into a mold where it meets the ends of the conductors to be welded. The temperature of the molten metal is sufficient to fuse the metal of the conductors, resulting in a welded molecular bond. Exothermic welding alloys are available for copper to copper and copper to steel (including stainless steel) connections. See Figure 4-55 for completed exothermic weld examples.



WARNING

To help prevent injury from molten metal or sparks and to reduce the risk of fire, follow the exothermic welding manufacturer’s safety warnings and requirements. Personnel performing an exothermic weld SHALL wear appropriate attire and safety devices.



CAUTION

If exothermically welding connections to a tower, contact the tower manufacturer for approved welding locations on the tower.



Figure 4-55 Examples of Completed Exothermic Welding



NOTE

The mold for copper-clad ground rods is different than for the same size solid copper, galvanized steel and stainless steel rods. The copper-clad rod is nominal size while the other rods are full size.



NOTE

Some molds, even when properly cared for, may last for only 50 welds.



IMPORTANT

Exothermic welding may be prohibited by specific component manufacturers, such as some towers or fences. Other suitable bonding methods listed in this chapter are allowed in these cases.

General requirements for exothermic welding are as follows:

- The manufacturer's instructions and safety requirements **shall** be observed.
- Heavy clothing, work shoes or boots, gloves, hard hat and safety glasses **shall** be worn when performing exothermic welding.
- Exothermic welding **shall not** be performed unless another person capable of rendering first aid is present.
- The molds **shall** be inspected for excessive wear or other defects.
- A suitable fire extinguisher and attendant **shall** be close by during the exothermic welding process.

- The proper weld material for the metals being welded **shall** be used.
- All metal parts **shall** be properly cleaned prior to welding.
- All metal parts and molds **shall** be properly dried prior to welding.
- The proper molds for the conductors and/or rods being welded **shall** be used.

4.8.7.1.1 Traditional Exothermic Welding Process

Figure 4-56 illustrates the typical traditional exothermic weld process.

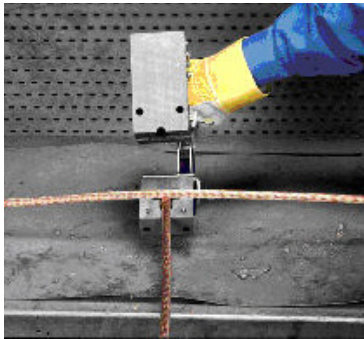

STEP 1:
Clean and dry conductors and mold.
insert conductors into mold.

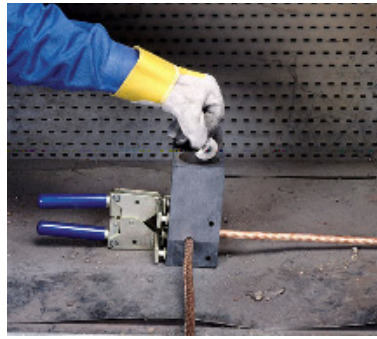

STEP 2:
Close handle clamp and lock mold.
Insert disk into mold.

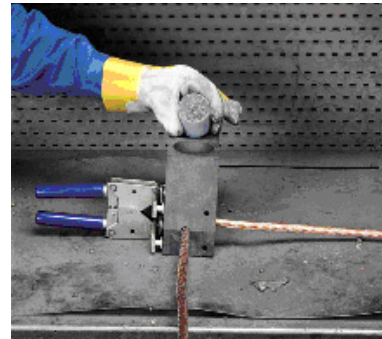

STEP 3:
Pour weld metal into mold.



STEP 4:
Sprinkle starting material over the
weld metal and close lid.

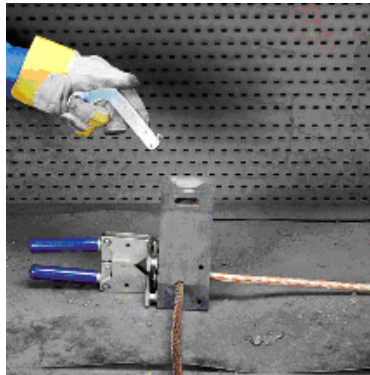

STEP5:
Ignite using a flint igniter.

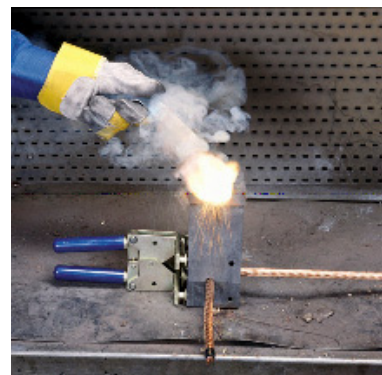

STEP 6:
Wait 15 to 20 seconds for the
reaction to complete, then open
the mold and remove the welded
connection.
Remove slag from the mold
before making the next
connection.

©Motorola Solutions Inc.
All rights reserved.

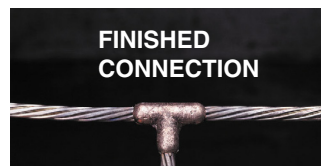

Figure 4-56 Traditional Exothermic Welding Process



WARNING

The exothermic welding process produces hot molten material with temperatures in excess of 1400° C (2500° F) and a localized release of smoke. Do not look directly at the “flash” of light from ignition of the welding materials and avoid inhalation of smoke/fumes.



IMPORTANT

Molds shall be adequately dried before attempting a weld. This is typically accomplished using an industrial heat gun or a small propane torch. Failure to adequately dry the mold may result in molten weld material violently spraying out and/or an ineffective weld.

4.8.7.1.2 Electronic Ignition Exothermic Welding Process

Traditionally, exothermic welding products relied on starting materials and a flint igniter as the ignition sources. Recently, new technologies have been developed that utilize electronic ignition to initiate the exothermic process. The electronic exothermic welding process also enhances safety because it allows the operator to initiate the exothermic process from a distance.

Figure 4-57 illustrates the typical electronic exothermic weld process.

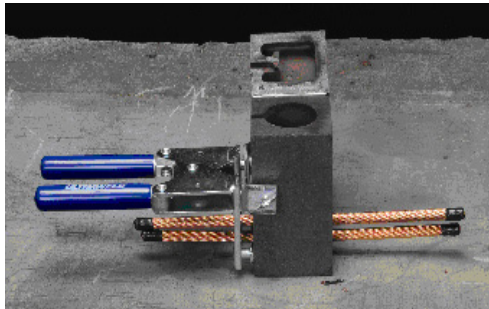

STEP 1:
Clean and dry conductors and mold.
Insert conductors into mold.

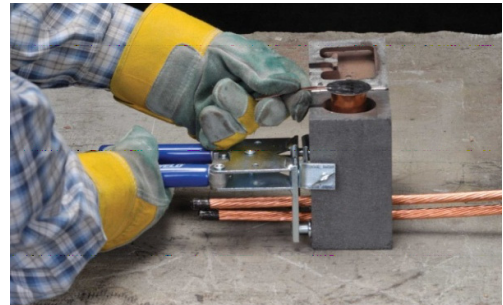

STEP 2:
Close and lock handle clamp.
Insert drop-in cartridge into mold.

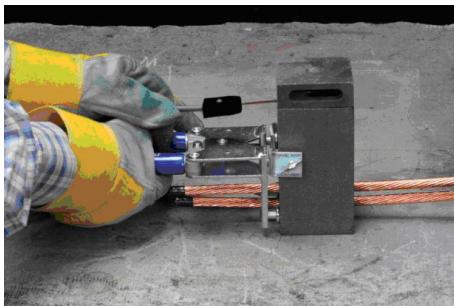

STEP 3:
Attach ignition cord to the electronic igniter.



STEP 4:
Press and hold igniter button(s).

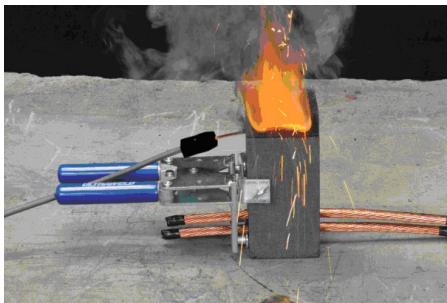

STEP 5:
Reaction occurs.
Wait 15-20 seconds, open mold and remove connection.
Remove slag before making the next connection.

©Motorola Solutions Inc. All rights reserved.

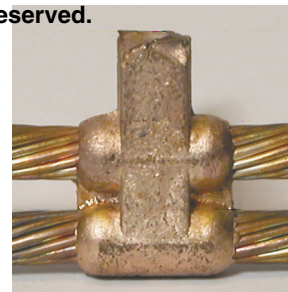

FINISHED CONNECTION

Figure 4-57 Electronic Ignition Exothermic Welding Process

WARNING

The exothermic welding process produces hot molten material with temperatures in excess of 1400° C (2500° F) and a localized release of smoke. Do not look directly at the “flash” of light from ignition of the welding materials and avoid inhalation of smoke/fumes.

IMPORTANT

Molds shall be adequately dried before attempting a weld. This is typically accomplished using an industrial heat gun or a small propane torch. Failure to adequately dry the mold may result in molten weld material violently spraying out and/or an ineffective weld.

4.8.7.1.3 Exothermic Weld Inspection Criteria

All exothermic welds **shall** be inspected to help ensure an acceptable bonding connection. Exothermic weld connections **shall** have a maximum DC resistance of one milliohm (1 mΩ) when measured between the bonded components with a 4-terminal milliohm/micro-ohm meter (FAA-STD-019e, sections 4.1.1.1 and 4.2.4.3.9; MIL-HDBK-419A Volume I, section 7.3; and NWSM 30-4106, section 2.8.5). Figure 4-58 illustrates an acceptable connection and some common unacceptable connections. See Figure 4-59 for a testing example.

Acceptable connection

Surface finish is bright, smooth, free of slag deposits and flashing around the connection.

Unacceptable connection

Not enough weld metal.

©Motorola Solutions, Inc. All rights reserved.

Unacceptable connection

Excessive slag and leakage due to mold not seated properly.

Unacceptable connection

Conductor not properly cleaned.

Figure 4-58 Examples of Exothermic Welds



Figure 4-59 Example of Micro-ohmmeter Testing

4.8.7.1.4 Common Exothermic Weld Problems

Table 4-13 provides guidance on some common exothermic weld problems:

Table 4-13 COMMON EXOTHERMIC WELD PROBLEMS

Problem	Possible Solution
Connection not sticking to bus bar	Weld to the edge of the bar. Preheat the bar (do not use a torch directly on the weld location).
Connection not sticking to galvanized steel	Completely remove galvanized coating with a rasp or similar tool.
Burn through on fence post	Use smaller sized gate jumper. Fill the post with sand past the connection point. Do not use water.
Melt through on cable to ground rod	Verify conductor is not under tension and support if required.
Inadequate weld, not enough weld material, incomplete weld or pitting of weld material	Clean and dry mold before attempting weld.

4.8.7.2 Irreversible High-Compression Fittings



WARNING

Wear safety glasses and other safety gear as recommended by the manufacturer when working with high-compression fittings.



NOTE

In this standard, a 2 ton connection is considered irreversible compression; a 12 ton connection is considered irreversible high-compression.

Irreversible high-compression connections are approved for above-grade and below-grade bonds and are an effective alternative to exothermic welding. Irreversible high-compression connections may be used in some applications where exothermic welding is not practicable due to safety concerns (such as at chemical or petroleum plants) and/or site specific conditions (such as a high water table). See Figure 4-60 for examples of high-compression fittings.

General requirements for irreversible high-compression connections are as follows:

- Connectors and fittings **shall** be listed by a Nationally Recognized Testing Laboratory (NRTL), such as CSA or UL (reference documents CSA C22.2 NO. 41-07 and UL 467-2007).
- Connectors and fittings **shall** be listed for the size and number of conductors being bonded.
- Connectors and fittings used underground **shall** be listed for direct burial.
- Connectors and fittings **shall** be rated for at least 10.8862 tonnes (12 tons) of force and **shall** be compressed to 10.8862 tonnes (12 tons) of force (FAA-STD-019e, section 4.2.4.3.9).
- Irreversible high-compression connections **shall** have a maximum DC resistance of one milliohm when measured between the bonded components with a 4-terminal milliohm/micro-ohm meter (FAA-STD-019e, sections 4.1.1.1 and 4.2.4.3.9; MIL-HDBK-419A Volume I, section 7.3; and NWSM 30-4106, section 2.8.5)
- The manufacturer instructions and requirements **shall** be followed.
- The manufacturer recommended compression tool **shall** be used. Where applicable, the appropriate die set **shall** be used for the compression fitting.
- The compression systems **shall** include crimped die index for purposes of inspection.
- The connectors and fittings **shall** be made of the same material (or compatible) as the materials being bonded to avoid dissimilar metal reactions.
- Aluminum connectors and fittings **shall not** be used.
- Conductors **shall** be properly cleaned prior to crimping to ensure good electrical contact. A wire brush is recommended for cleaning the conductor.
- Connections **shall** be coated with a conductive anti-oxidant compound before crimping (see “Anti-Oxidant Compound” on page 4-63).



©Motorola Solutions, Inc. All rights reserved.

Figure 4-60 Irreversible High-Compression Connectors and Typical Crimping Tools



NOTE

Some compression connectors and lugs come pre-filled with an anti-oxidant compound. In these instances, additional compound is not required.

4.8.7.2.1 Irreversible High-Compression Inspection Criteria

All irreversible high-compression connections **shall** be inspected to help ensure an acceptable bonding connection. Irreversible high-compression connections **shall** have a maximum DC resistance of one milliohm (1 mΩ) when measured between the bonded components with a 4-terminal milliohm/micro-ohm meter (FAA-STD-019e, sections 4.1.1.1 and 4.2.4.3.9; MIL-HDBK-419A Volume I, section 7.3; and NWSM 30-4106, section 2.8.5).

See Figure 4-59 for a testing example.

Figure 4-61 illustrates the typical irreversible compression connector installation process for a 90° splice connection between two conductors. Refer to the connector manufacturer and tool manufacturer for specific instructions.

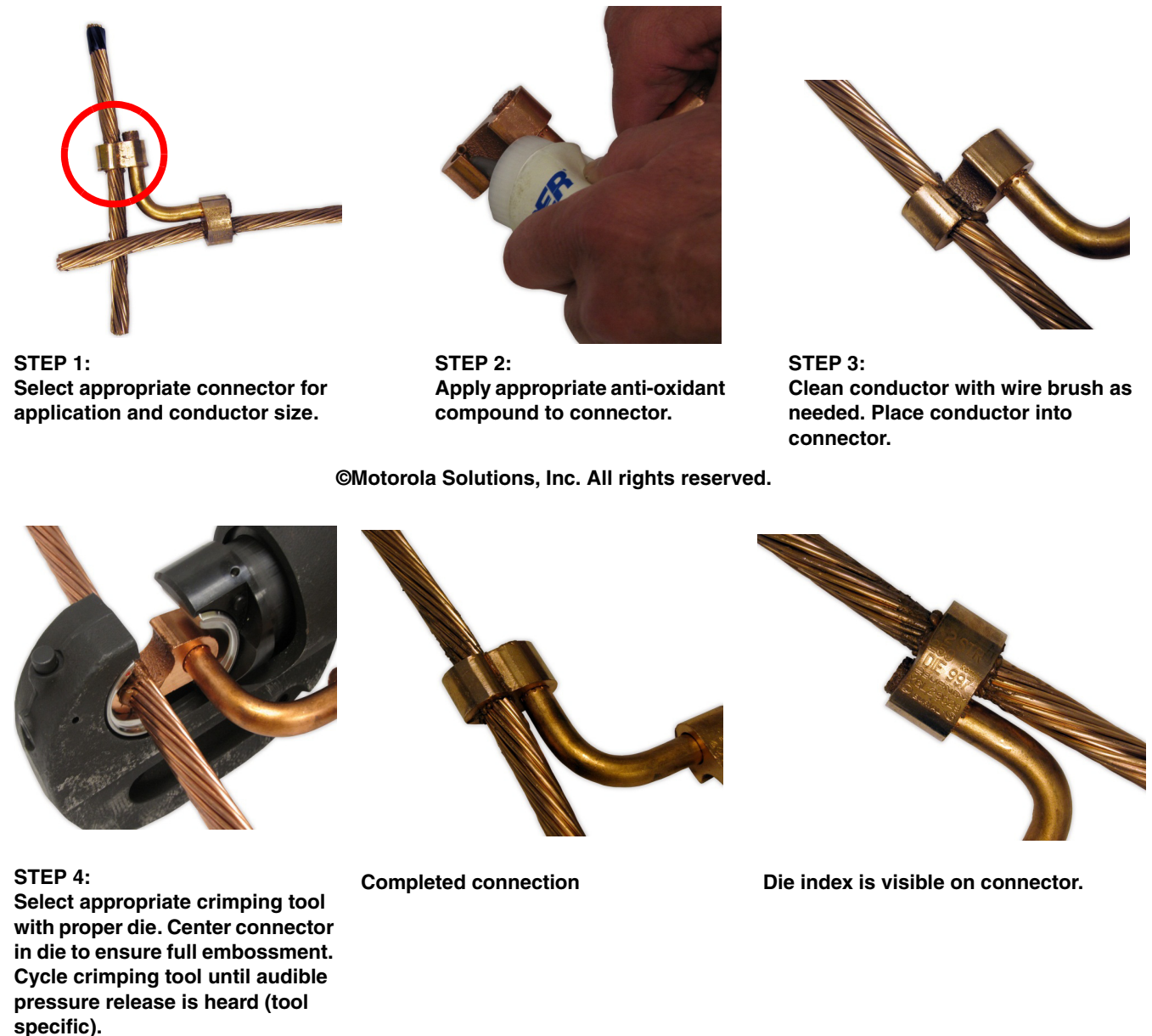

Figure 4-61 Typical High-Compression 90° Splice Connection Process

4.8.8 Bonding Summary

Table 4-14 lists approved bonding conductors and bonding methods for typical sites. The Table is not intended to be an all-inclusive list. Specific site design and/or conditions may require variation from this matrix. If variation is required, consultation with Motorola Solutions Engineering is recommended.

Table 4-14 BONDING MATRIX

Metallic Item to be Bonded		Approved Conductor		Approved Connection Method				
Item	Bonded To	Type	Min. Size	Exothermic Weld	Irreversible-Compression Connector	Listed 2-Hole Lug ¹	Listed Single-Hole Lug ¹	Listed Mechanical Clamp Designed for the Purpose ²
Guy Wire	Grounding Conductor	Tinned-copper or Galvanized guy wire	#2 AWG	—	—	—	—	✓
Galvanized Steel Fence or Gate Post	Grounding Conductor	Copper or Tinned-copper ³	#2 AWG	✓	—	—	—	✓
Galvanized Steel Fence Fabric	Grounding Conductor	Tinned-copper	#2 AWG	—	—	—	—	✓
Fence Deterrent Wire	Grounding Conductor	Tinned-copper	#2 AWG	—	—	—	—	✓
Gate Frame	Gate Supporting Post	Jacketed flexible copper bonding jumper ⁴	#6 AWG	✓	—	—	—	✓
Fuel Tank Footing or Supplied Grounding Post	Grounding Conductor	Copper or Tinned-copper ³	#2 AWG	✓ ⁵	—	✓	—	—
Generator Frame or Supplied Grounding Post	Grounding Conductor	Copper or Tinned-copper ³	#6 AWG or #2 AWG if routed below grade	✓ ⁵	—	✓	—	—
Bollard Post	Grounding Conductor	Copper or Tinned-copper	#2 AWG	✓	—	—	—	—
Galvanized Steel Tower Leg or Grounding Plate	Tower Grounding Electrode Conductor	Copper or Tinned-copper ³	#2 AWG	✓ ⁵	—	✓ ⁶	—	✓
Bottom Tower Ground Bus Bar	Grounding Electrode Conductor	Copper or Tinned-copper	#2 AWG	✓	✓	—	—	—
Tower Ground Bus Bar	Tower structure	N/A: Direct mechanical bond		—	—	—	—	Appropriate stainless steel clamp and hardware
Intermediate Tower Ground Bus Bar	Tower Ground Bus Bar Bonding Jumper	Jacketed copper or Tinned-copper	#2 AWG	✓	✓	✓	—	—
Intermediate Tower Ground Bus Bar Bonding Jumper	Tower structure	Jacketed copper or Tinned-copper	#2 AWG	✓ ⁵	—	—	—	✓

Table 4-14 BONDING MATRIX (CONTINUED)

Metallic Item to be Bonded		Approved Conductor		Approved Connection Method				
Item	Bonded To	Type	Min. Size	Exothermic Weld	Irreversible-Compression Connector	Listed 2-Hole Lug ¹	Listed Single-Hole Lug ¹	Listed Mechanical Clamp Designed for the Purpose ²
External Ground Bus Bar	Grounding Electrode Conductor	Copper or Tinned-copper	#2 AWG	✓	✓	—	—	—
External Ground Bus Bar	Copper Strap	N/A		✓	—	—	—	Per Mfr Design
Communications Cable Grounding Kits	Ground Bus Bar	Copper or Tinned-copper	#6 AWG	✓	—	✓	✓	—
Ice Bridge/Cable Bridge Supporting Post	Grounding Conductor	Copper or Tinned-copper ³	#2 AWG	✓	—	—	—	✓ ⁷
Ice Bridge/Cable Bridge Sections	Ice Bridge/Cable Bridge Support Post	Jacketed Copper	#6 AWG	✓	—	—	—	✓ ⁷
Ice Bridge/Cable Bridge Sections	Ice Bridge/Cable Bridge Bonding Jumper	Jacketed Copper	#6 AWG	✓ ⁵	—	✓	—	—
HVAC Unit	Grounding Conductor	Copper or Tinned-copper	#2 AWG	—	—	✓	—	—
Copper or copper-clad Grounding Electrode	Ground Ring or Grounding Electrode Conductor	Copper or Tinned-copper	#2 AWG	✓	✓	—	—	—
Stainless Steel Grounding Electrode	Ground Ring or Grounding Electrode Conductor	Copper or Tinned-copper	#2 AWG	✓	✓	—	—	—
Galvanized Steel Grounding Electrode	Ground Ring or Grounding Electrode Conductor	Tinned-copper	#2 AWG	✓	✓	—	—	—
Metallic Items Requiring Bonding	Grounding Conductor	Copper or Tinned-copper	#6 AWG or #2 AWG if routed below grade	✓ ⁵	—	✓	✓ ⁸	✓
Tower Top Amplifier	Grounding Conductor	Jacketed copper or Tinned-copper	#6 AWG or #2 AWG if TTA contains a surge protective device	—	—	✓	✓	—

1. Listed tin-plated compression lug

2. Listed stainless steel or tin-plated copper alloy with stainless steel hardware

3. Tinned-copper is required if using mechanical clamps

4. Such as 133-strand
5. As permitted by manufacturer
6. To plate only if exothermic welding is not permitted by tower
7. Mechanical clamps are only allowed if exothermic welding is not permitted at the specific site
8. Objects subject to vibration shall not use single-hole lugs

4.9 Minimum Site Grounding (Earthing) Requirements

This section provides the minimum grounding requirements for installing a grounding electrode system at a communications site and for bonding site equipment to the grounding electrode system. Reasonable attempts **shall** be made to achieve the grounding electrode system resistance design goal, as defined in “Grounding (Earthing) Electrode System Resistance Requirements” on page 4-76.

The recommended first steps for installing a typical grounding electrode system are as follows:

- Determine the site type classification (Light Duty, Standard Duty or Extra Duty). See “Site Type Classification: Definitions” on page 4-5.
- Review Table 4-15 and the appropriate sections in this chapter to determine the minimum design requirements and recommendations for the site type.

Table 4-15 GROUNDING ELECTRODE SYSTEM REQUIREMENTS MATRIX

	Grounding Electrode System Design					
	Resistance Design Goal ¹	Single Ground Rod	Building Ground Ring ²	Tower Ground Ring ²	Supplemental Techniques	Concrete-encased Electrodes
Light Duty Site (A)	25 Ω	✓ ³	—	N/A	Recommended to achieve the 25 Ω design goal ⁴	Recommended for new construction
Standard Duty Sites (B):						
Building Only	10 Ω	—	✓	N/A	Recommended to achieve the 10 Ω design goal ⁴	Recommended for new construction
Building and Tower	10 Ω	—	✓	✓	Recommended to achieve the 10 Ω design goal ⁴	Recommended for new construction
Building and Tower in High-lightning Area	10 Ω	—	✓	✓	Radials Recommended ⁵	Recommended for new construction
Building Only at Site with High Soil Resistivity ⁵	10 Ω	—	✓	N/A	✓ ⁴	Recommended for new construction
Building and Tower at Site with High Soil Resistivity ⁵	10 Ω	—	✓	✓	✓ ⁴	Recommended for new construction
Extra Duty Sites (B2):						

Table 4-15 GROUNDING ELECTRODE SYSTEM REQUIREMENTS MATRIX (CONTINUED)

	Grounding Electrode System Design					
	Resistance Design Goal ¹	Single Ground Rod	Building Ground Ring ²	Tower Ground Ring ²	Supplemental Techniques	Concrete-encased Electrodes
Communications or 911-Dispatch Center with co-located Tower	5 Ω	—	✓	✓	Radials Recommended ⁵	Recommended for new construction
Master or Prime Site with co-located Tower	5 Ω	—	✓	✓	Radials Recommended ⁵	Recommended for new construction

1. See “Resistance Design Goal Not Achieved” on page 4-78
2. With ground rods installed every 10-15 ft as described in this chapter
3. Two ground rods are recommended regardless of the actual resistance to earth
4. Such as electrolytic grounds rods, grounding electrode encasement material, ground mesh, radial grounding conductors or other supplemental techniques appropriate for the site.
5. Or other supplemental technique appropriate for the site
6. Soil resistivity is considered high when the resistance design goal cannot be achieved without supplemental grounding techniques.

- Determine the resistance design goal requirement of the grounding electrode system, based on the site type classification (Light Duty, Standard Duty or Extra Duty).
- Perform a soil resistivity test at the site as described in Appendix B, “Soil Resistivity Measurements”.
- Calculate the resistance of a single ground rod as described in Appendix B, “Soil Resistivity Measurements”.
- Continue to the subsections “Type “A” Site: Light Duty” or “Type “B” and “B2” Sites: Standard and Extra Duty”, based on site type classification.

**NOTE**

Throughout this document, areas with a lightning flash density greater than 2 flashes/km²/year are considered high-lightning areas. See “Lightning Activity and Exposure” on page 4-3.

4.9.1 Type “A” Site: Light Duty

Continued from “Minimum Site Grounding (Earthing) Requirements” on page 4-74:

- Determine if the single ground rod will meet the minimum 25 Ω requirement. If the single ground rod does not meet the 25 Ω requirement, an additional ground rod or other grounding electrode, will be required. See “Type “A” Site Grounding (Earthing)” on page 4-78 for additional information.
- Install the ground rod(s) as described in “Light Duty (Type A) Sites” on page 4-16.

**NOTE**

It is recommended to use two grounding electrodes as the minimum installation, even if 25 ohms is achieved with a single grounding electrode.

4.9.2 Type “B” and “B2” Sites: Standard and Extra Duty

Continued from “Minimum Site Grounding (Earthing) Requirements” on page 4-74:

- Using a site drawing, determine where to install the minimum required ground rods, while maintaining equal separation between rods. See “External Building and Tower Ground Ring” on page 4-25 for additional information regarding ground rod placement requirements along ground rings. In general, a ground rod should be installed every 3 m to 4.5 m (10 to 15 ft).
- Determine if radial grounding conductors should be installed at the site, such as when the site is located in a geographic area that is highly prone to lightning or when the site is normally occupied, such as a dispatch center. See “Radial Grounding Conductors” on page 4-28.
- Calculate the resistance of the grounding electrode system using “Calculating Resistance of Complex Ground Rod Systems” on page B-29 or consult with an engineering firm.
- If the resistance design goal cannot be achieved, recalculate using one or more of the supplemental techniques described in “Supplemental Grounding (Earthing)” on page 4-78.
- Develop a detailed site grounding electrode system drawing based on the previous steps.
- Install the grounding electrode system using components and techniques as specified throughout this chapter.
- Test the grounding electrode system resistance to earth as described in Appendix D.
- Bond all external metal objects to the grounding electrode system as required throughout this chapter. See “Metallic Objects Requiring Bonding” on page 4-101.

4.9.3 Grounding (Earthing) Electrode System Resistance Requirements

In order to disperse lightning energy into the earth without causing dangerous over-voltages, the shape and dimensions of the grounding electrode system are more important than a specific resistance value of the grounding electrode system. However, a low resistance grounding electrode system is generally recommended (IEC 61024-1-2). Attempts should be made to reduce the grounding electrode system resistance to the lowest practicable value (MIL-HDBK-419A, section 2.2.3).



NOTE

Although grounding electrode system resistance is important and should be met whenever practicable, it alone does not determine the suitability of the grounding electrode system to properly dissipate and control lightning energy. The resistance of the grounding electrode system is only a general measure of merit. Proper design and installation of the grounding electrode system, installation of ground rings, ground rods, radial grounding conductors, and the bonding of systems and equipment, are as important as the resistance to earth.

Effective grounding electrode system shape and dimensions are achieved through the proper installation of the required and recommended grounding electrode system components listed throughout this chapter. The required and recommended grounding electrode system components are, but not limited to, the following:

- **Building ground ring.** See “External Building and Tower Ground Ring” on page 4-25.
- **Tower ground ring.** See “External Building and Tower Ground Ring” on page 4-25.
- **Ground rods** properly installed and spaced around the building and tower ground rings. See “Ground Rods” on page 4-12.
- **Radial grounding conductors** for high lightning prone geographical areas, sites that are normally occupied (such as 911 dispatch centers), sites with high soil resistivity or where bedrock prohibits the driving of ground rods. See “Radial Grounding Conductors” on page 4-28.
- **Proper bonding of all grounding electrode system components.** See “Common Grounding” on page 4-6 and “Bonding to the External Grounding and Bonding System” on page 4-57.
- **Proper bonding of all ancillary equipment.** See “Common Grounding” on page 4-6 and “Metallic Objects Requiring Bonding” on page 4-101.

The grounding electrode system resistance requirement is determined based on the classification of the site. Communications sites are classified by this standard into three categories:

- **Type A – Light Duty:** See “Site Type Classification: Definitions” on page 4-5.

- **Type B – Standard Duty:** See “Site Type Classification: Definitions” on page 4-5.
- **Type B2 – Extra Duty:** See “Site Type Classification: Definitions” on page 4-5.

4.9.3.1 Type “A” Sites: Light Duty

Type “A” sites **shall** have a grounding electrode system **resistance design goal of 25 ohms or less for a single grounding electrode** (NFPA 70-2017, Article 250.53; MIL-HDBK-419A, section 2.2.2.1; and TIA-607-C, Annex C). See Figure 4-62 for a typical single grounding electrode installation for a Type A site.

If the design goal of 25 ohms cannot be achieved throughout the year with a single grounding electrode, then the grounding electrode **shall** be augmented with at least one additional grounding electrode (NFPA 70-2017, Article 250.53). See “Soil Resistivity Variability and Factors Affecting Soil Resistivity” on page B-2 for information regarding the seasonal variations in grounding electrode resistance. See Figure 4-12 for an example of two parallel ground rods.



NOTE

It is recommended to use two grounding electrodes as the minimum installation, even if 25 ohms is achieved with a single grounding electrode.

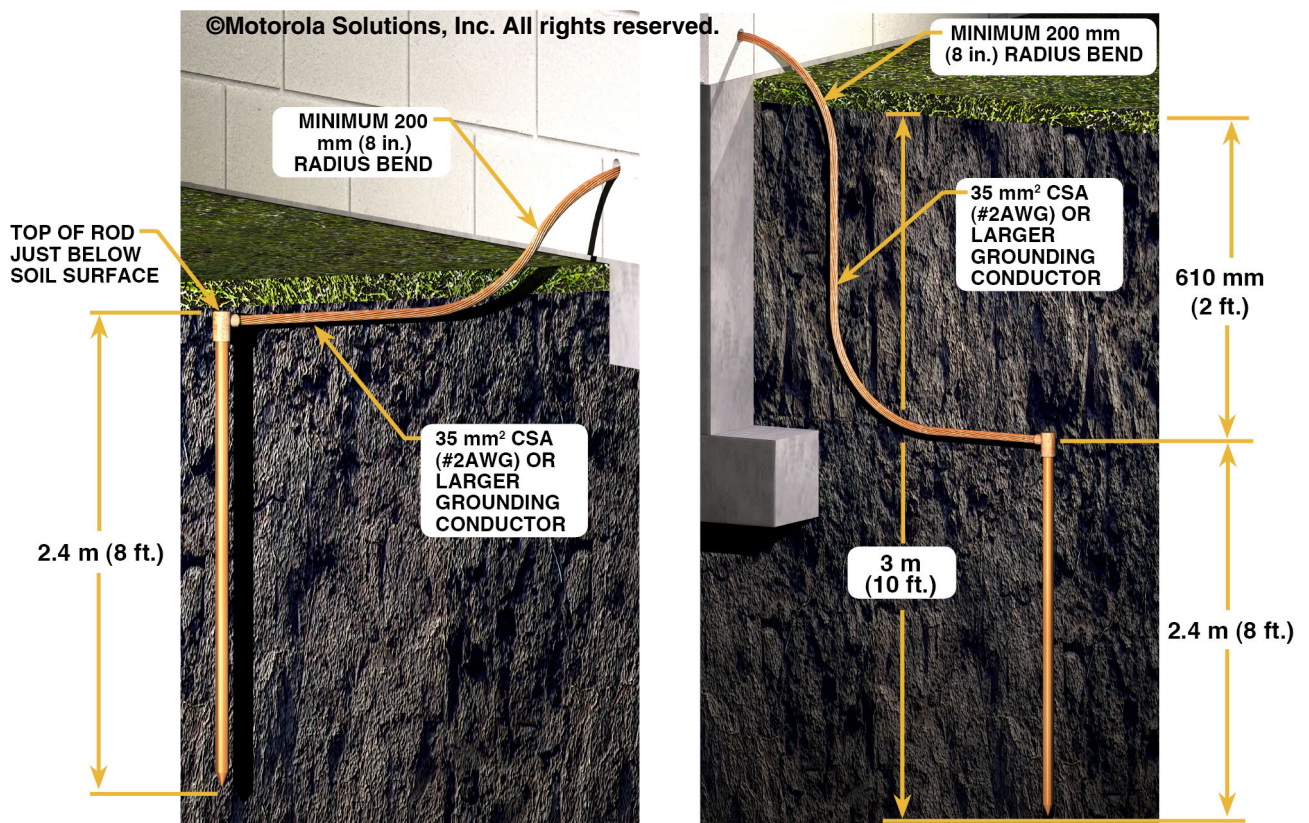

Figure 4-62 Typical Single Grounding Electrode Installations For Type A Sites

4.9.3.2 Type “B” Sites: Standard Duty

Type “B” sites **shall** have a grounding electrode system **resistance design goal of 10 ohms or less** (ANSI/TIA-222-G-2005, AS/NZS 5070.1:2008, BS/EN 62305-3, FAA STD 019e, IEC 62305-3:2010, ITU Earthing and Bonding Handbook, MIL-HDBK-419A, and MIL-STD-188-124A).

4.9.3.3 Type “B2” Sites: Extra Duty

Type “B2” sites **shall** have a grounding electrode system **resistance design goal of 5 ohms** or less (see IEEE 142-2007, section 4.1.3; IEEE 1100-2005, section 9.9.1.3; IEEE 1692-2011, section 8.1; TIA-607-C, section C.2.3; and the United States National Weather Service Manual 30-4106-2005, section 2.8).

4.9.3.4 Resistance Design Goal Not Achieved

If the resistance design goal cannot be achieved with the minimum required grounding electrode system (see “Minimum Site Grounding (Earthing) Requirements” on page 4-74), reasonable efforts **shall** be made to achieve the design goal using supplemental grounding techniques. The supplemental grounding techniques are described in “Supplemental Grounding (Earthing)” on page 4-78.



NOTE

If the resistance design goal for a Type B or B2 site cannot be met after reasonable and appropriate attempts are made to supplement the grounding electrode system, no further grounding is required at the site. See “Supplemental Grounding (Earthing)” for more information regarding supplemental grounding. Review from Motorola Solutions Engineering or other engineering firm is recommended when the resistance design goal is not met.

4.9.4 Supplemental Grounding (Earthing)

At sites with high (poor) soil resistivity, it may be difficult to achieve the grounding electrode system resistance design goal without enhancements. Type B and B2 sites that do not meet the resistance design goal **shall** require enhancements to the grounding electrode system. Sites in high lightning prone geographical areas, and sites normally occupied (such as dispatch centers), should also include enhancements to the grounding electrode system, regardless if the resistance requirements are met. See ATIS-0600313.2013, section 10.3.2.

Some techniques for enhancing the grounding electrode system are as follows:

- Installation of radial grounding conductors. See “Radial Grounding Conductors” on page 4-28.
- Installation of concrete-encased electrodes in new construction. See “Concrete-Encased Electrodes” on page 4-23.
- Installation of longer ground rods. See “Ground Rod Installation” on page 4-13.
- Installation of electrolytic ground rods. See “Electrolytic Ground Rods” on page 4-19.
- Installation of wire mesh. See “Wire Mesh” on page 4-32.
- Use of grounding electrode encasement materials. See “Grounding (Earthing) Electrode Encasement Materials” on page 4-35.
- Specific design by Motorola Solutions Engineering or other engineering firm.



NOTE

Doubling the length of a ground rod reduces its resistance to earth by approximately 45% (assuming homogeneous soil).

4.9.5 Type “A” Site Grounding (Earthing)

At sites defined as Type “A”, a single ground rod may be sufficient if it can achieve 25 ohms or less throughout the year. If a single ground rod cannot achieve 25 ohms or less throughout the year, then the ground rod **shall** be augmented by an additional grounding electrode (NFPA 70-2017, Article 250.53; MIL-HDBK-419A, section 2.2.2.1; and TIA-607-C, section C.2.3). See Figure 4-12 for an example of an augmented ground rod (additional ground rod in parallel). Other alternate methods may also be used, such as the following:

- Installation of concrete-encased electrodes as part of new construction and bonding to the ground rod. See “Concrete-Encased Electrodes” on page 4-23.
- Installation of a longer rod that can achieve 25 ohms or less throughout the year. See “Ground Rod Installation” on page 4-13.

- Installation of an electrolytic ground rod that can achieve 25 ohms or less throughout the year. See “Electrolytic Ground Rods” on page 4-19.
- Installation of a small ground ring. See Figure 4-112.

**NOTE**

It is recommended to use two grounding electrodes as the minimum installation, even if 25 ohms is achieved with a single grounding electrode.

A typical Type “A” grounding system is shown in Figure 4-62. At an existing building, the AC power system grounding electrode system will typically serve adequately as the communications Type “A” grounding electrode system.

A supplemental Type “A” grounding electrode system may need to be installed if the site has an RF transmission line (or other communications cables) entry point at a different location than the AC power utilities entrance. If a supplemental Type “A” grounding electrode system is installed, it **shall** be bonded to the electrical service grounding electrode system and any other grounding electrode system at the site. See “Common Grounding” on page 4-6. For an example of bonding a supplemental grounding electrode system to an existing AC power service grounding electrode system, see Figure 4-96, Figure 4-99, Figure 4-100 and Figure 4-112.

**NOTE**

A single 2.4 m × 15.9 mm (8 ft × 0.625 in.) ground rod requires a soil resistivity of approximately 6,250 ohm-cm or less throughout the year in order to achieve a resistance value of 25 ohms; a 3 m × 15.9 mm (10 ft × 0.625 in.) ground rod would require 7,500 ohm-cm; a 4.9 m × 15.9 mm (16 ft × 0.625 in.) ground rod would require 11,200 ohm-cm; and a 6.1 m × 15.9 mm (20 ft × 0.625 in.) ground rod would require 13,600 ohm-cm. See Appendix B, “Soil Resistivity Measurements,” for additional information.

4.9.6 Tower Grounding (Earthing)

An external grounding electrode system for a communications tower is required to dissipate lightning energy before it reaches the associated communications facility. Although it is impossible to prevent all lightning energy from entering the communications facility, the majority of the lightning energy can be controlled and diverted to earth (ATIS-0600313.2013, section 10.1, and ATIS-0600334.2013, section 5.1). Antenna masts and metal support structures **shall** be grounded (NFPA 70-2017, Article 810.15).

**IMPORTANT**

For towers installed at high lightning prone geographical areas or sites normally occupied (such as 911 dispatch centers), radial grounding conductors should be employed to improve equalization of the grounding electrode system (see ATIS-0600313.2013, section 10.3.2, and ATIS 0600334.2013, section 5.4). Where radials are used, each tower leg should be bonded to the ground ring with two conductors (ATIS-0600313.2013, section 10.3.2). Where two grounding conductors are used, they should be separated from each other by 90 degrees. See “Radial Grounding Conductors” on page 4-28. This is recommended even if the grounding electrode system resistance design goal is achieved without the use of radial grounding conductors.

Towers can be classified into three basic categories (ATIS-0600334.2013, section 6.3):

- Metallic Self-Supporting (including monopoles)
- Metallic Guyed
- Wooden Structures (poles)

**CAUTION**

Some antenna support structures, such as water storage tanks, may require special grounding and bonding techniques due to the possibility of corrosion. Tinned-copper conductors and stainless steel ground rods may be a viable option to help control corrosion in these types of applications. Consultation with the tank owner and an engineering firm is recommended.

**WARNING**

High voltage hazards may exist with utility pole and transmission tower installations. Only properly trained and qualified personnel SHALL perform communications equipment installations and maintenance at these locations. Qualification and training SHALL be determined by the utility and/or Authority Having Jurisdiction. Installations at these locations require careful coordination with the utility in order to ensure a safe installation and SHALL follow applicable OSHA regulations (or equivalent). Installations at these locations SHALL meet all installation and clearance requirements of the *National Electrical Safety Code*[®] (or equivalent) and the electric utility. Installation at these locations SHALL require consultation with Motorola Solutions Engineering, other engineering firm and/or the electric utility.

4.9.6.1 Self-Supporting Towers (Including Monopoles)

Self-supporting towers **shall** minimally be grounded (earthed) as follows:

4.9.6.1.1 General Requirements for Self-Supporting Towers

- The tower **shall** be encircled by a ground ring (ATIS-0600334.2013, section 5, and MIL-HDBK-419A).
- The tower ground ring **shall** be installed at least 610 mm (2 ft) from the tower structure base or footing (ATIS-0600334.2013, section 5.3.1).
- The tower ground ring **shall** be installed according to “External Building and Tower Ground Ring” on page 4-25.
- The tower ground ring **shall** be bonded to the building ground ring in at least two points using two 35 mm² csa (#2 AWG) or larger, bare, copper grounding conductors (ATIS-0600334.2013, Figure 1; MIL-STD-188-124B; and TIA-607-C, section C.2.5). See “External Building and Tower Ground Ring” on page 4-25, Figure 4-24 and Figure 4-26.
- The tower's support piers (concrete footings) should have the rebar electrically connected to the tower holding (anchor) bolts (ATIS-0600313.2013, section 10.3.1, and TIA-607-C, section C.2.4). See Figure 4-66.
- Install radial grounding conductors if needed. See “Radial Grounding Conductors” on page 4-28 and “Dispatch Centers Co-Located With Communications Towers” on page 4-122.

4.9.6.1.2 Ground Rod Requirements

**IMPORTANT**

When only two ground rods are used, the ground rods should be separated from each other as much as practicable (ideally the sum of their respective lengths). See “Ground Rod Resistance Characteristics and Sphere of Influence” on page 4-9.

**IMPORTANT**

Tower ground rings shall contain ground rods as needed to limit the distance between ground rods from 3 m to 4.5 m (10 to 15 ft).

- For towers not exceeding 1.5 m (5 ft) in base width (including monopoles): the tower ground ring shall consist of at least two ground rods installed on opposite (diametrically opposed) sides (ATIS-0600313.2013, section 10.3.1, and ATIS-0600334.2013, section 5.2) and additional ground rods as needed to limit the distance between ground rods from 3 m to 4.5 m (10 to 15 ft). See Figure 4-63 and Figure 4-65.

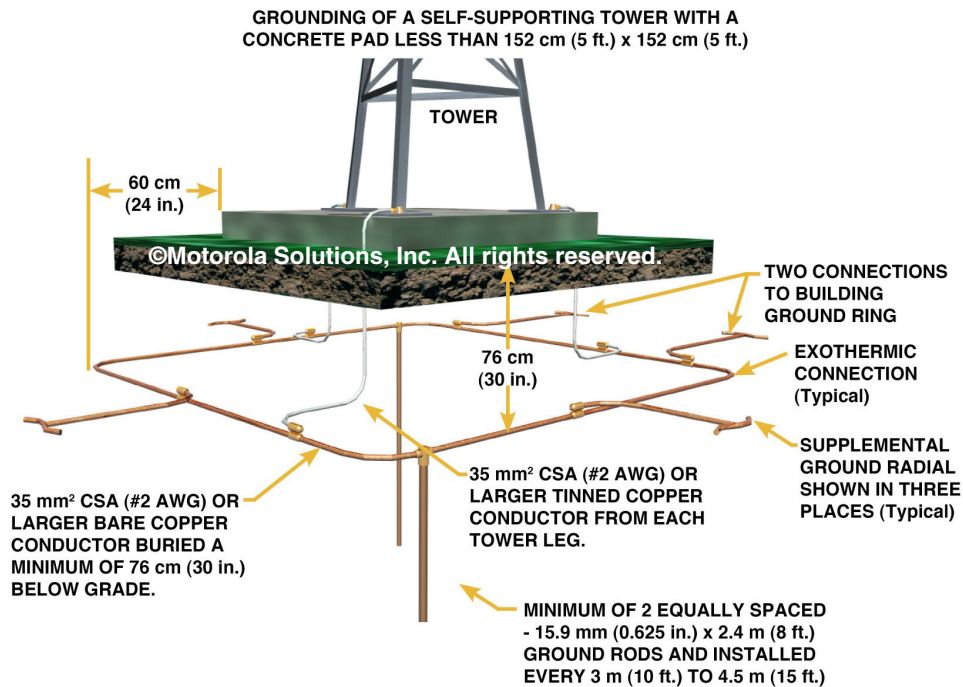

Figure 4-63 Example of Self-Supporting Tower Grounding

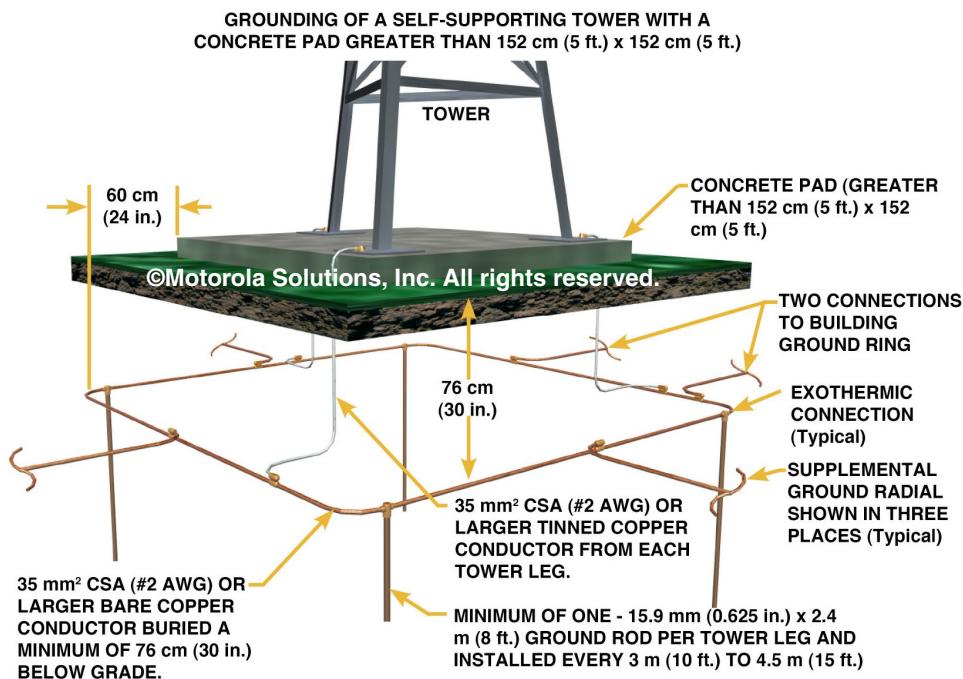

Figure 4-64 Example of Self-Supporting Tower Grounding

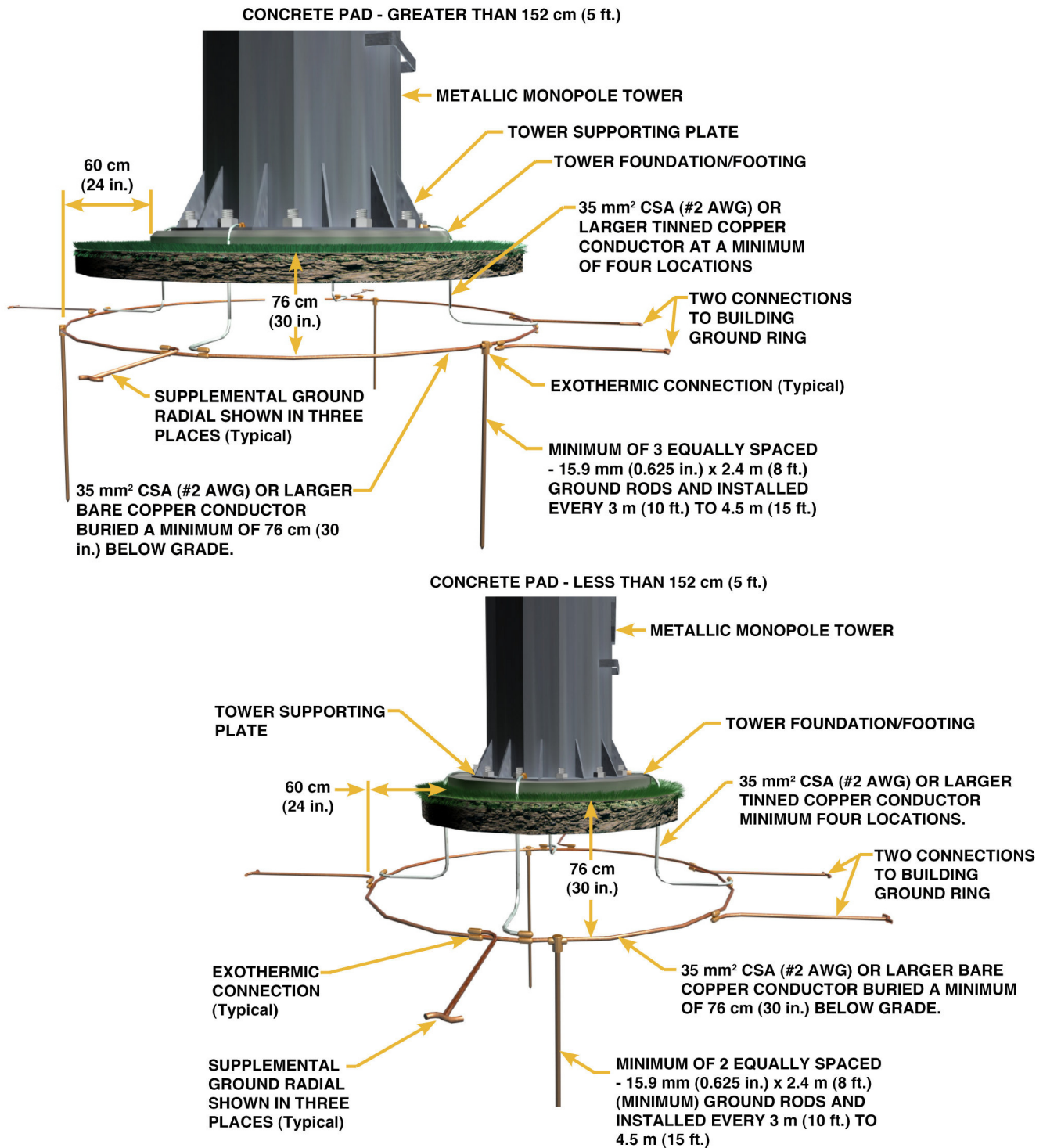

Figure 4-65 Examples of Monopole Tower Grounding

- **For towers equal to or exceeding 1.5 m (5 ft) in base width (not including monopoles):** the tower ground ring **shall** consist of at least one ground rod per tower structure leg (ATIS-0600313.2013, section 10.3.1, and ATIS-0600334.2013, section 5.3.2) and additional ground rods as needed to limit the distance between ground rods from 3 m to 4.5 m (10 to 15 ft). See Figure 4-64.
- **For monopole towers equal to or exceeding 1.5 m (5 ft) in base width:** the tower ground ring **shall** consist of at least three equally spaced ground rods and additional ground rods as needed to limit the distance between ground rods from 3 m to 4.5 m (10 to 15 ft). See Figure 4-65.
- Ground rods **shall** meet the specifications and be installed according to “Ground Rods” on page 4-12.

4.9.6.1.3 Bonding and Conductor Requirements

- Each leg of a self-supporting tower **shall** be bonded to the tower ground ring using 35 mm² csa (#2 AWG) or larger, bare, copper grounding conductors. If the bonding connection to the tower leg uses mechanical hardware, tinned-copper conductors **shall** be used. See “Grounding (Earthing), Bonding and Down-Conductors” on page 4-37. See Figure 4-63 and Figure 4-64.
- Monopole towers **shall** be bonded to the tower ground ring using at least four equally spaced 35 mm² csa (#2 AWG) or larger, bare, copper grounding conductors (TIA-607-C, section C.2.4.2). See Figure 4-65.
- The tower grounding conductors **shall** be exothermically bonded to the tower structure unless specifically directed otherwise by the tower manufacturer. If mechanical hardware is used instead of exothermic welding, tinned-copper conductors **shall** be used. See “Grounding (Earthing), Bonding and Down-Conductors” on page 4-37.
- Grounding conductors **shall** meet the requirements of “Grounding (Earthing), Bonding and Down-Conductors” on page 4-37. Tinned-copper conductors should be used to help prevent galvanic corrosion.



CAUTION

Before attempting exothermic welding of tower grounding connections, contact the tower manufacturer to identify approved locations for exothermic welds on the tower.

4.9.6.2 Guyed Towers

Guyed towers **shall** minimally be grounded (earthed) as follows:

4.9.6.2.1 General Requirements for Guyed Towers

- The tower **shall** be encircled by a ground ring (ATIS-0600334.2013, section 5.3, and MIL-HDBK-419A).
- The tower ground ring **shall** be installed at least 610 mm (2 ft) from the tower structure base or footing (ATIS-0600334.2013, section 5.3.1).
- The tower ground ring **shall** be installed according to “External Building and Tower Ground Ring” on page 4-25.
- The tower ground ring **shall** be bonded to the building ground ring in at least two points using two 35 mm² csa (#2 AWG) or larger, bare, copper grounding conductors (ATIS-0600334.2013, Figure 1; MIL-STD-188-124B; and TIA-607-C, section B.2.5). See “External Building and Tower Ground Ring” on page 4-25, Figure 4-24 and Figure 4-26.
- Install radial grounding conductors if needed. See “Radial Grounding Conductors” on page 4-28 and “Dispatch Centers Co-Located With Communications Towers” on page 4-122.
- The tower's support piers (concrete footings) should have the rebar electrically connected to the tower holding (anchor) bolts (ATIS 0600313.2013, section 10.3.1, and TIA-607-C, section C.2.4). Ensure all anchor bolts and rebar cage are bonded together (ATIS-0600334.2013, section 6.3.1). See Figure 4-66 for an example.

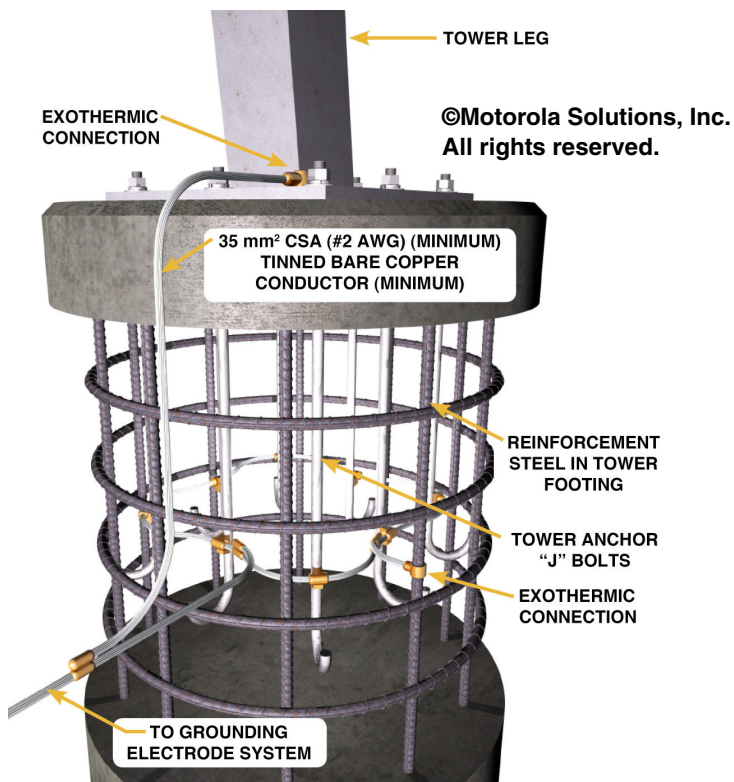

Figure 4-66 Tower Anchor Bolts Bonded to Rebar Cage and Grounding Electrode System

4.9.6.2.2 Ground Rod Requirements

- The tower ground ring **shall** contain at least two ground rods installed on opposite (diametrically opposed) sides (ATIS-0600313.2013, section 10.3.1, and ATIS-0600334.2013, section 5.2) and additional ground rods as needed to limit the distance between ground rods from 3 m to 4.5 m (10 - 15 ft).
- Ground rods **shall** meet the specifications and be installed according to “Ground Rods” on page 4-12.



IMPORTANT

When only two ground rods are used, the ground rods should be separated from each other as much as practicable (ideally the sum of their respective lengths). See “Ground Rod Resistance Characteristics and Sphere of Influence” on page 4-9.



IMPORTANT

Tower ground rings shall contain ground rods as needed to limit the distance between ground rods from 3 m to 4.5 m (10 to 15 ft).

4.9.6.2.3 Bonding and Conductor Requirements

- The tower **shall** bond to the grounding electrode system using one of the following techniques (see Figure 4-67 and TIA-607-C, section C.2.4.1):
 - The tower bottom plate bonded to the tower ground ring using at least three equally spaced 35 mm² csa (#2 AWG) or larger, bare, copper grounding conductors.

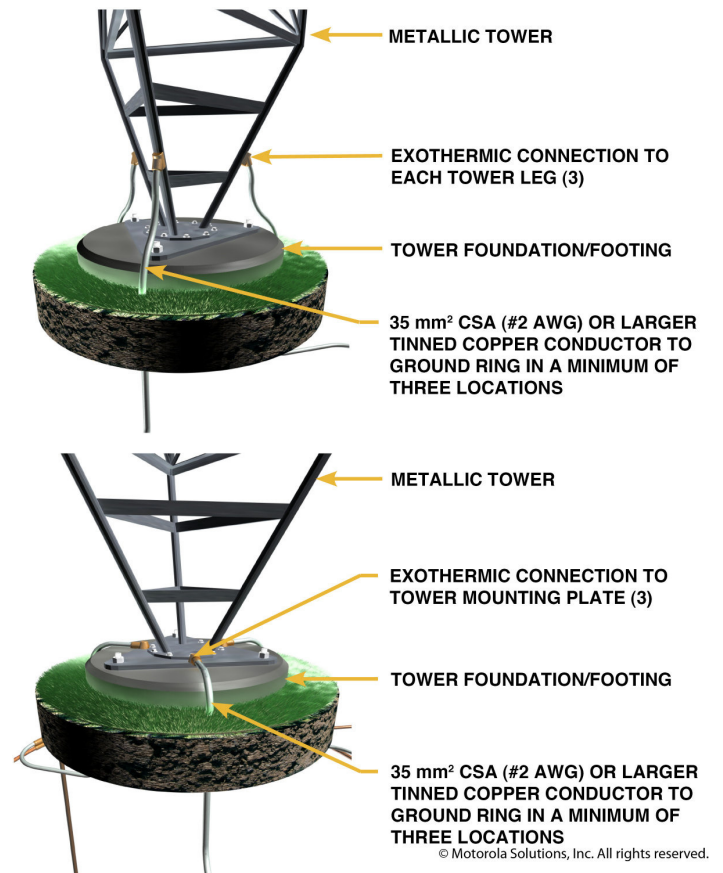
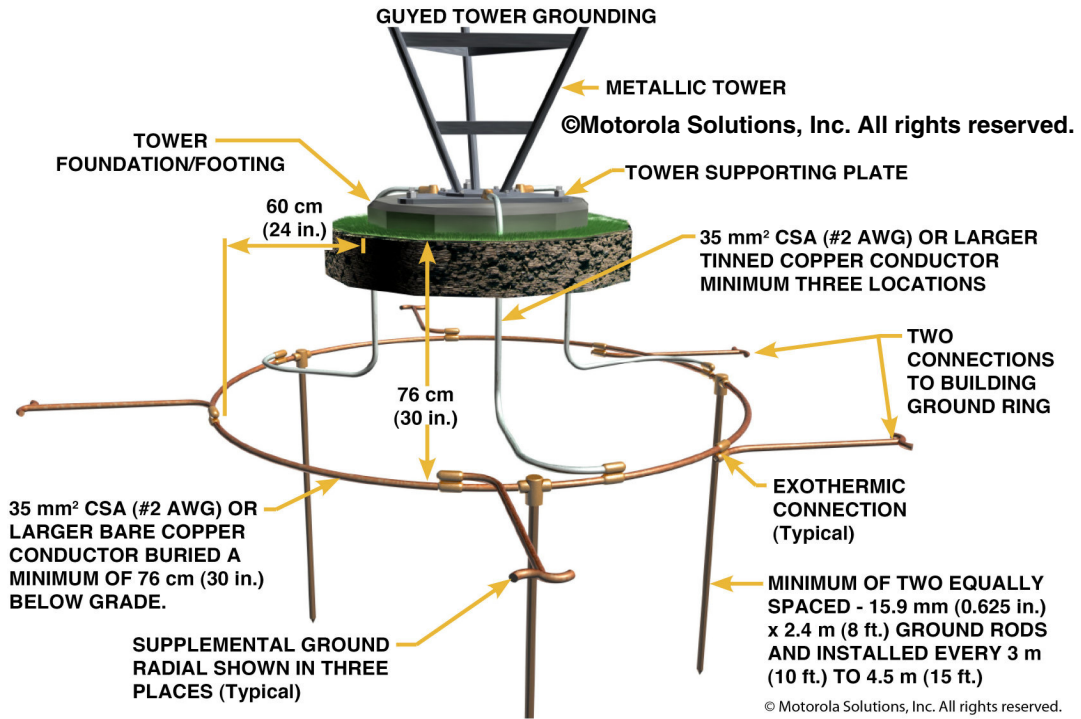

Figure 4-67 Examples of Guyed Tower Grounding

- Each leg bonded to the tower ground ring using 35 mm² csa (#2 AWG) or larger, bare, copper grounding conductors. If the bonding connection to the tower leg uses mechanical hardware, tinned-copper conductors **shall** be used.
- The tower side face plates (minimum of three) bonded to the tower ground ring using 35 mm² csa (#2 AWG) or larger, bare, copper grounding conductors. If the bonding connection to the tower side face plate uses mechanical hardware, tinned-copper conductors **shall** be used.
- The tower grounding conductors **shall** be exothermically bonded to the tower structure unless specifically directed otherwise by the tower manufacturer. If mechanical hardware is used instead of exothermic welding, tinned-copper conductors **shall** be used. See “Grounding (Earthing), Bonding and Down-Conductors” on page 4-37.
- Grounding conductors **shall** meet the requirements of “Grounding (Earthing), Bonding and Down-Conductors” on page 4-37. Tinned-copper conductors should be used to help prevent galvanic corrosion.



CAUTION

Before attempting exothermic welding of tower grounding connections, contact the tower manufacturer to identify approved locations for exothermic welds on the tower.

4.9.6.2.4 Steel Guy Anchor Point Grounding

Grounding steel guy anchor points require special attention due to the possibility of galvanic corrosion damage to the anchor points.



IMPORTANT

Although various methods for grounding guy anchor points are possible, any variation from the requirements and guidelines in this section shall be designed by an engineering firm. A corrosion specialist should be consulted for all guy anchor installations.

Steel guy wire anchor points **shall** minimally be grounded as outlined in the following sections.



NOTE

Non-metallic guy wires do not require grounding.

4.9.6.2.5 New Construction

- The guy anchor **shall** be installed in a manner that prevents direct contact with soil. This is accomplished by encasing the guy anchor in reinforced concrete over its entire embedded length. The concrete encasement **shall** extend a minimum of 152 mm (6 in.) above grade (see ANSI/TIA-222-G, ANNEX H and TIA-607-C, Figure 30).



NOTE

Encasing the anchor in reinforced concrete over the entire embedded length of the anchor helps prevent galvanic corrosion from the guy anchor to copper components of the grounding electrode system. Galvanized steel encased in concrete has a similar potential to that of copper (see “Miscellaneous General Information” on page 4-55). Additionally, encasing the anchor in reinforced concrete over the entire embedded length of the anchor will help prevent the galvanic corrosion that would otherwise exist from the portion of the anchor in direct contact with soil to the portion encased in concrete.

- A ground rod **shall** be installed at each guy anchor point (ATIS-0600313.2013, section 10.3.1, and ANSI/TIA-222-G, section A.10.0).
- Ground rods **shall** meet the specifications and be installed according to “Ground Rods” on page 4-12.
- The ground rod **shall** be installed at least 610 mm (2 ft) from the guy anchor footing.

- The guy anchor **shall** bond to the ground rod (ATIS-0600313.2013, section 10.3.1, and ANSI/TIA-222-G, section A.10.0).
- All guy wires at a guy anchor point **shall** bond to the ground rod (ATIS-0600313.2013, section 10.3.1, and ANSI/TIA-222-G, section A.10.0) using a 35 mm² csa (#2 AWG) or larger, bare, **tinned**, copper conductor (see Figure 4-68). Stranded conductor is recommended to help prevent conductor breakage due to vibrations. Alternately, the guy anchor point can be grounded as shown in Figure 4-69, using galvanized guy wire as the above-grade conductor (see NWSM 30-4106, section 2.7.9.6). Using galvanized guy wire is the preferred method.

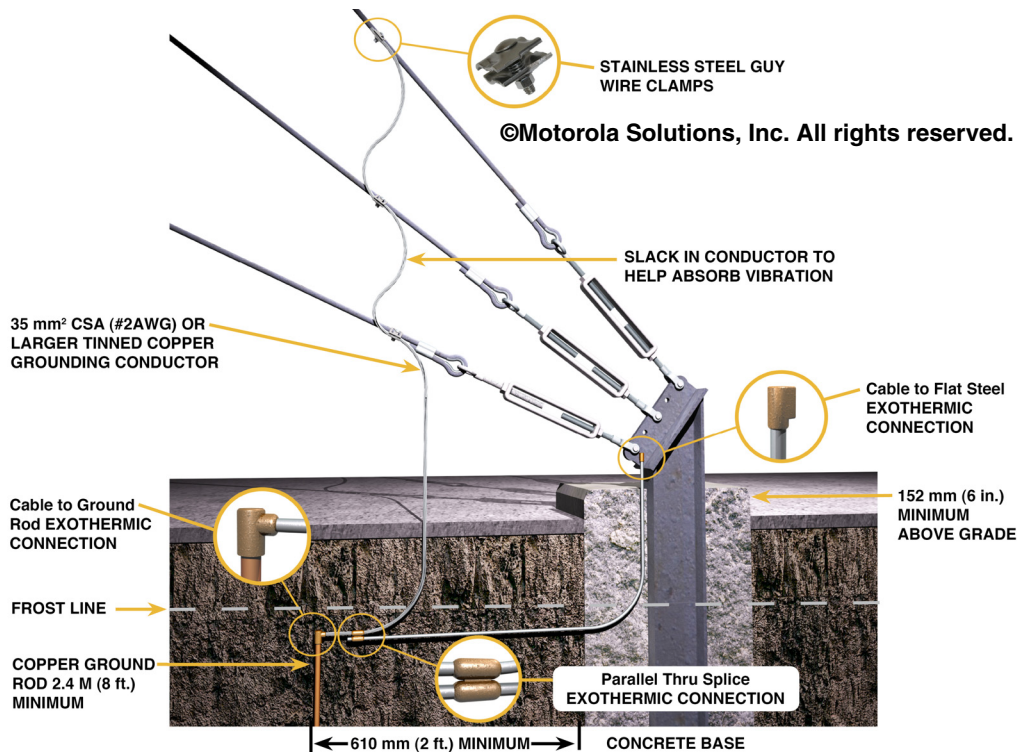

Figure 4-68 Guy Anchor Point Grounding for New Construction

- The grounding conductor **shall** be connected to each guy wire using stainless steel or other approved clamps. Each connection **shall** be coated with a listed conductive anti-oxidant compound. See “Anti-Oxidant Compound” on page 4-63.



CAUTION

Do not attempt to exothermically weld to tower guy wires.

- The grounding conductor **shall** be connected to the guy wires above the turnbuckles.
- The grounding conductor **shall** maintain a continuous smooth flow from the guy wire attachment point to the grounding electrode. An S-shape pattern **shall** be used to help absorb guy wire vibrations and prevent breakage of the grounding conductor.



IMPORTANT

Grounding conductors used at guy anchor points shall be tinned-copper to help prevent galvanic corrosion and should be stranded to help prevent conductor breakage due to vibrations. Alternately, galvanized guy wire may be used as shown in Figure 4-69.

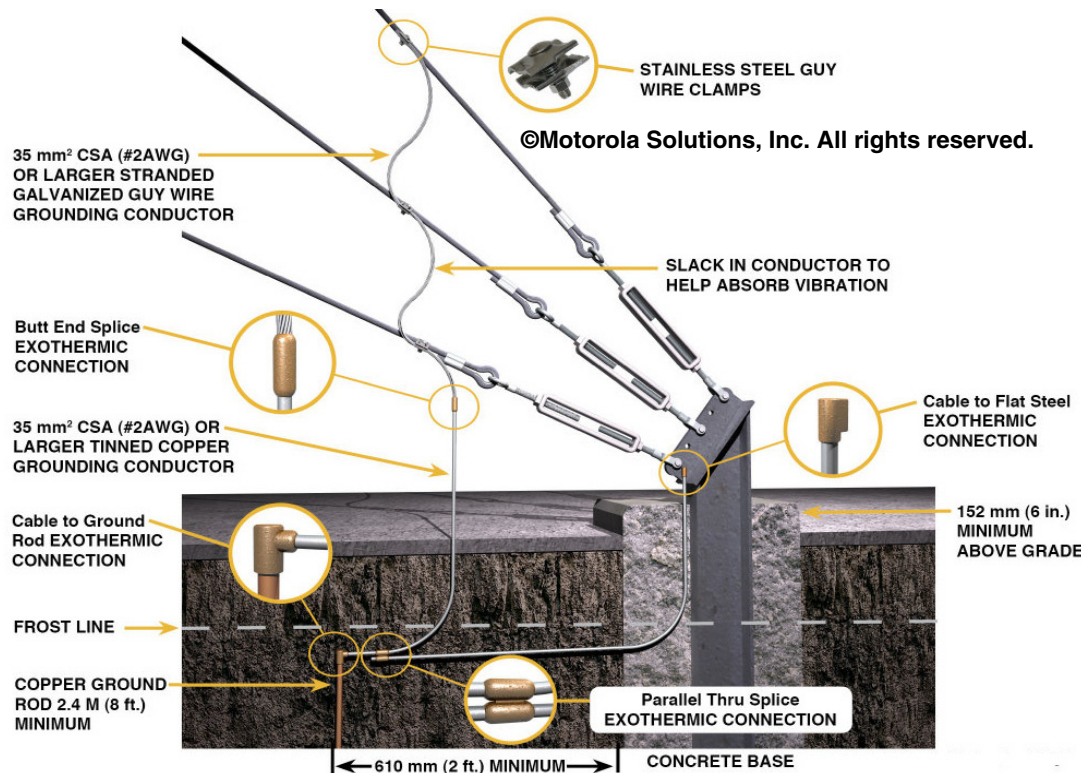
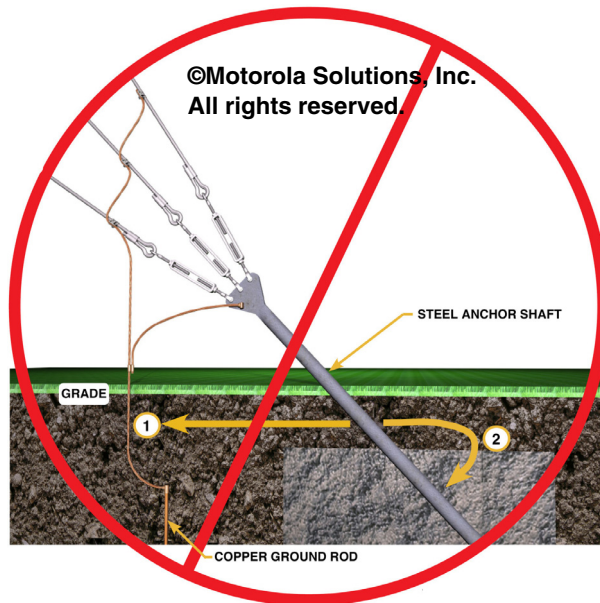

Figure 4-69 Guy Anchor Point Grounding for New Construction (Using Guy Wire as the Above-Grade Bonding Conductor)

4.9.6.2.6 Existing Anchor Points in Direct Contact with Soil

See Figure 4-70 and Figure 4-71 for details.

- If practicable, backfill around the embedded anchor with a high resistivity soil, such as gravel. This may be beneficial in reducing the rate of corrosion between the guy anchor point and copper grounding electrode system components. See ANSI/TIA/EIA-222-F-R2003; Annex J, section 4.1.
- Isolation of anchors from the structure using guy insulators may help reduce the transmission of stray currents from outside sources, therefore, minimizing electrolytic corrosion (TIA/EIA-222-F-R2003, section 4.1). Guy isolators should only be installed under the advice of a professional engineer. Galvanic corrosion due to the presence of copper ground rods is greatly reduced if the ground wires are connected on the tower side of the isolation point (ANSI/TIA/EIA-222-F-R2003, section 4.1).
- A ground rod **shall** be installed at each guy anchor point (ANSI/TIA-222-G, section A.10.0). Ground rods **shall** meet the specifications and be installed according to “Ground Rods” on page 4-12. In order to reduce galvanic corrosion from the galvanized guy anchor point to a nearby copper ground rod, this ground rod **shall** be constructed of galvanized steel, unless a guy insulator is used (ANSI/TIA/EIA-222-F-R2003, section 4.1).
- The guy anchor **shall** bond to the ground rod (ATIS-0600313.2013, section 10.3.1, and ANSI/TIA-222-G, section A.10.0).
- All guy wires at a guy anchor point **shall** bond to the ground rod (ATIS-0600313.2013, section 10.3.1, and ANSI/TIA-222-G, section A.10.0) using a 35 mm² csa (#2 AWG) or larger, bare, **tinned**, copper conductor. Stranded conductor is recommended to help prevent conductor breakage due to vibrations. Alternately, the guy anchor point may be grounded as shown in Figure 4-69, using galvanized guy wire as the above-grade conductor (see NWSM 30-4106, section 2.7.9.6). Using galvanized guy wire is the preferred method.



1. CORROSION FROM STEEL ANCHOR SHAFT TO COPPER GROUND ROD AND OTHER COPPER GROUNDING ELECTRODE SYSTEM COMPONENTS.
2. CORROSION FROM STEEL ANCHOR SHAFT TO THE PORTION OF ANCHOR SHAFT ENCASED IN CONCRETE (STEEL ENCASED IN CONCRETE IS SIMILAR TO COPPER)

Figure 4-70 Example of Guy Anchor Galvanic Corrosion

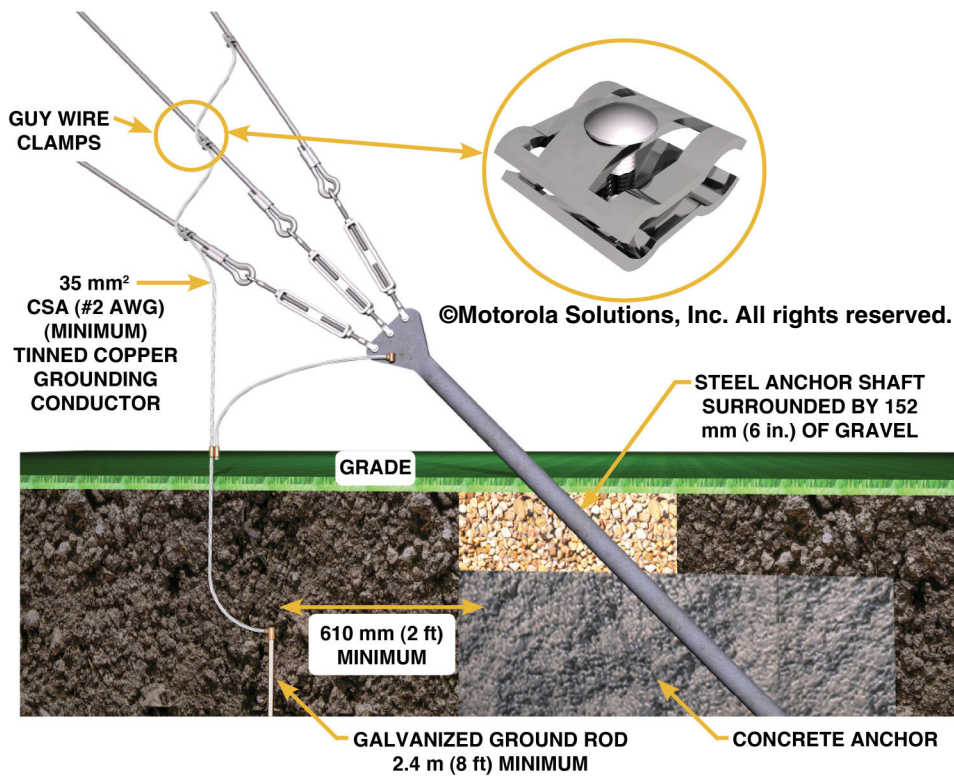

Figure 4-71 Guy Anchor Point Grounding for Existing Construction

- The grounding conductor **shall** be connected to each guy wire using stainless steel or other approved clamps. Each connection **shall** be coated with a listed conductive anti-oxidant compound. See “Anti-Oxidant Compound” on page 4-63.

**CAUTION**

Do not attempt to exothermically weld to tower guy wires.

- The grounding conductor **shall** be connected to the guy wires above the turnbuckles.
- The grounding conductor **shall** maintain a continuous smooth flow from the guy wire attachment point to the grounding electrode. An S-shape pattern **shall** be used to help absorb guy wire vibrations and prevent breakage of the grounding conductor.

**IMPORTANT**

Grounding conductors used at guy anchor points shall be tinned-copper to help prevent galvanic corrosion and should be stranded to help prevent conductor breakage due to vibration. Alternately, galvanized guy wire may be used as shown in Figure 4-69.

4.9.6.2.7 Cathodic Protection for Guy Anchors

Additional corrosion control can be obtained through the use of cathodic protection. See MIL-HDBK-419A Volume I, section 2.10; ITU Bonding and Earthing Handbook, section 3.12; and TIA/EIA-222-F-R2003, section 4.4, for additional information.

**IMPORTANT**

Cathodic protection systems should be installed only under the advice and direction of a corrosion specialist.

Galvanic and electrolytic corrosion occurs when current flows from the anchor into the surrounding soil. The objective of cathodic protection is to reverse the direction of current, resulting in current flowing to the anchor instead of away from it, thereby preventing corrosion of the anchor. This can be achieved by installing galvanic anodes or by introducing an impressed current.

By electrically connecting a metal (galvanic anode) listed higher on the galvanic series and burying it in close proximity, current can be forced to flow to the guy anchor. This will result in corrosion of the installed metal anode instead of the guy anchor. For this reason, the installed metal is called a sacrificial anode and also why these anodes must be periodically inspected to make sure they have not corroded away beyond use. Additional sacrificial anode material may eventually have to be added. A common sacrificial anode used is magnesium packaged in a prepared backfill mixture to enhance its conductivity with soil.

The number, size, type and location of galvanic anodes should be determined by a corrosion specialist and **shall** be adequate to ensure current flows in the correct direction, overcoming the effects of all other influences at the site. The effectiveness of an installed system should be periodically monitored over the life of the structure by a corrosion specialist. This may be done by measuring the potential of the protected anchor with respect to a reference electrode placed in the ground. A large enough negative potential indicates that current is flowing to the anchors as desired for corrosion control. See ANSI/TIA/EIA-222-F, ANNEX J 4.4.

**IMPORTANT**

Any type of corrosion control installation techniques does not eliminate the need for proper monitoring and maintenance over the life of the structure (ANSI/TIA/EIA-222-F-R2003, section 4).

4.9.6.3 Wooden Structures (Poles)



NOTE

Non-metallic towers (such as carbon fiber and concrete) **shall** be grounded in the same manner as described in this section. The antenna supports and transmission lines **shall** be grounded as shown in Figure 4-72.

Wooden pole structure towers (and other non-metallic towers) **shall** minimally be grounded as follows (see Figure 4-72 and TIA-607-C, section C.2.4.3):

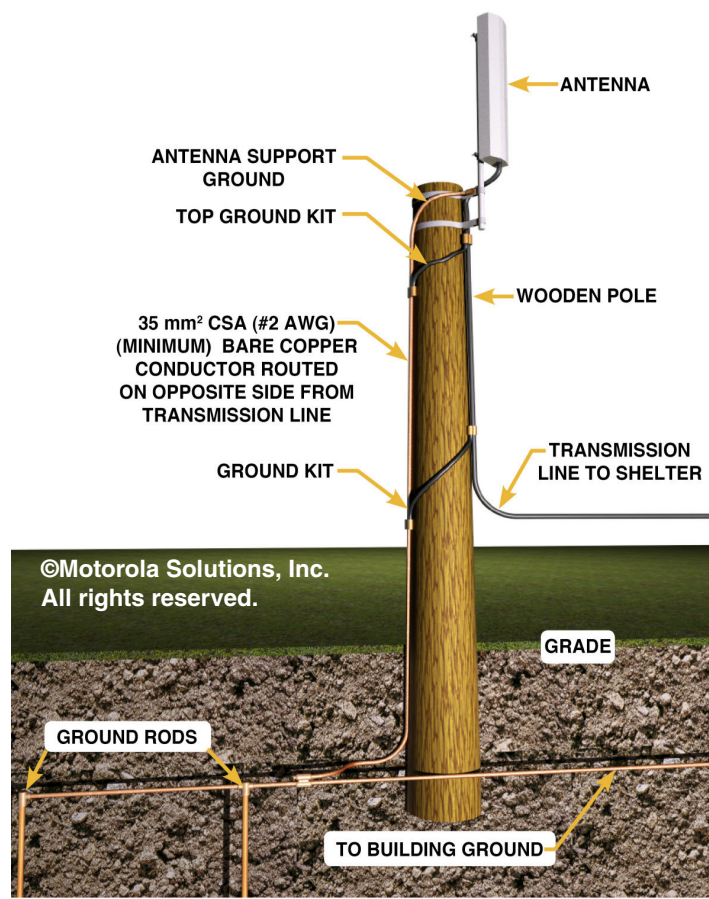

Figure 4-72 Wooden Pole Grounding

- The wooden pole **shall** have a vertical grounding conductor installed along the length of the wooden pole.
- The vertical grounding conductor **shall** be constructed of 35 mm² csa (#2 AWG) or larger, solid, bare, copper (ATIS-0600334.2013, section 6.5). It is recommended to size the grounding conductor according to Table 4-5.
- The grounding conductor **shall** be installed according to “Grounding (Earthing), Bonding and Down-Conductors” on page 4-37.
- The vertical grounding conductor **shall** terminate into a radial grounding conductor or tower ground ring (with rods) (ATIS-0600334.2013, section 6.5).
- The radial grounding conductor **shall** be installed according to “Radial Grounding Conductors” on page 4-28.
- The tower ground ring **shall** be installed according to “External Building and Tower Ground Ring” on page 4-25.
- Ground rods **shall** meet the specifications and be installed according to “Ground Rods” on page 4-12.

- The wooden pole grounding electrode system **shall** be bonded to the building grounding electrode system. See “Common Grounding” on page 4-6.

4.9.7 Dedicated Communications Building Grounding (Earthing)

All dedicated communications buildings **shall** have a properly installed external grounding electrode system. The grounding electrode system resistance **shall** meet the requirements of “Grounding (Earthing) Electrode System Resistance Requirements” on page 4-76.

A typical site grounding electrode system layout is shown in Figure 4-73. The building grounding electrode system requirements are as follows and **shall** also include any supplemental grounding required to achieve the resistance design goal. See “Minimum Site Grounding (Earthing) Requirements” on page 4-74.

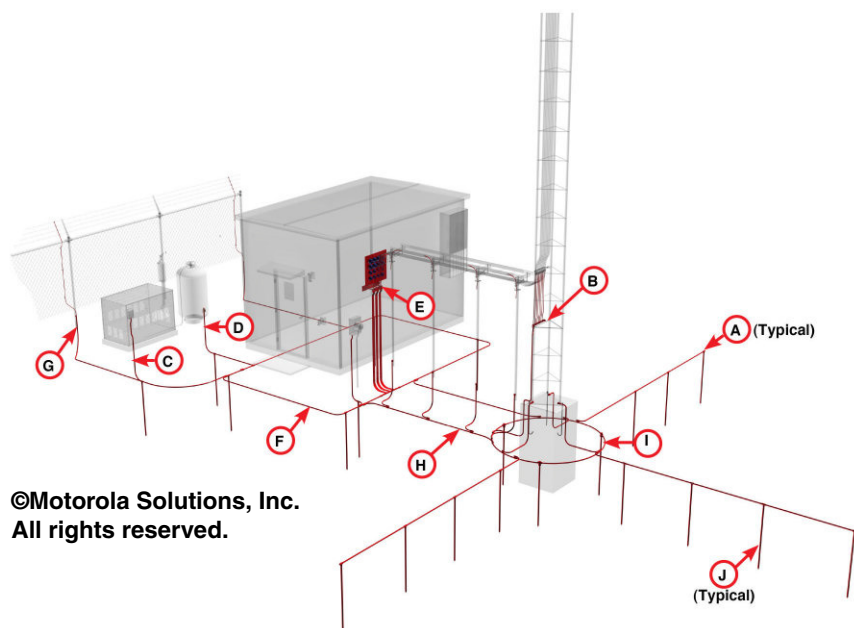

©Motorola Solutions, Inc.
All rights reserved.

A:	Grounding Radials
B:	Tower Ground Bus Bar and Down Conductors
C:	Generator Grounding Conductor
D:	Fuel Tank Grounding Conductor
E:	External Ground Bus Bar
F:	Shelter Ground Ring
G:	Fence Grounding Conductor
H:	Ground Ring Bonding Conductor (2 minimum)
I:	Tower Ground Ring
J:	Earthing Electrodes (Ground Rods)

Figure 4-73 Dedicated Communications Building Grounding

- Installation of concrete-encased electrodes as part of new construction. See “Concrete-Encased Electrodes” on page 4-23.
- Where practicable, the building **shall** be encircled by a ground ring installed according to “External Building and Tower Ground Ring” on page 4-25 (see IEEE 1692-2011, section 8.2).
- The building ground ring **shall** have a ground rod installed near the External Ground Bus bar (EGB), at each corner of the shelter and as follows:
 - If 2.4 m (8 ft) ground rods are used, additional ground rods **shall** be installed as needed to reduce the distance between rods from 3 m to 4.5 m (10 to 15 ft) (ATIS-0600334.2013, section 5.3.2).
 - If longer ground rods are used, a larger separation proportional to the increase in rod length may be used.

- The ground rods **shall** be installed according to “Ground Rods” on page 4-12.
- The ground rods **shall** be exothermically welded to the ground ring or as otherwise allowed in “Bonding to the External Grounding and Bonding System” on page 4-57.
- The building ground ring **shall** be bonded to the tower ground ring using a minimum of two 35 mm² csa (#2 AWG) or larger bare copper conductors. See “External Building and Tower Ground Ring” on page 4-25 and Figure 4-26.
- The tower (if applicable) **shall** be grounded according to “Tower Grounding (Earthing)” on page 4-79 (see IEEE 1692-2011, section 8.2).
- Determine if radial grounding conductors should be installed at the site. See “Radial Grounding Conductors” on page 4-28. A minimum of four radial grounding conductors are recommended (IEEE 1692-2011, section 8.2).
- Ground and bond the external generator (if installed) as described in “Generators External to the Building” on page 4-93.
- Ground and bond devices and metallic objects as described in this chapter.

4.9.8 Generators External to the Building

Generators installed outside of the building, within 1.8 m (6 ft) of the building, **shall** be bonded to the nearest practicable location on the grounding electrode system as shown in Figure 4-74 and Figure 4-75, using a 16 mm² csa (#6 AWG) or larger, copper conductor (ATIS-0600313.2013, Figure 3(a) and ATIS-0600334.2013, section 5.3.3). Grounding conductors routed below-grade or partially below-grade, **shall** be 35 mm² csa (#2 AWG) or larger.

External generator grounding **shall** comply with the following:

- Bonding to the generator chassis **shall** be done according to the manufacturer's requirements. Two-hole compression lugs **shall** be used where practicable (see Figure 4-51).
- The grounding conductors **shall** meet the requirements of “Grounding (Earthing), Bonding and Down-Conductors” on page 4-37.
- Bonding to the grounding electrode system (below grade) **shall** be made using exothermic welding or listed irreversible high-compression fittings. Bonding to an available ground bus bar (above-grade) **shall** be made using exothermic welding, listed irreversible high-compression fittings or listed two-hole compression lugs (see Figure 4-50 for a compression lug example). See “Bonding to the External Grounding and Bonding System” on page 4-57.

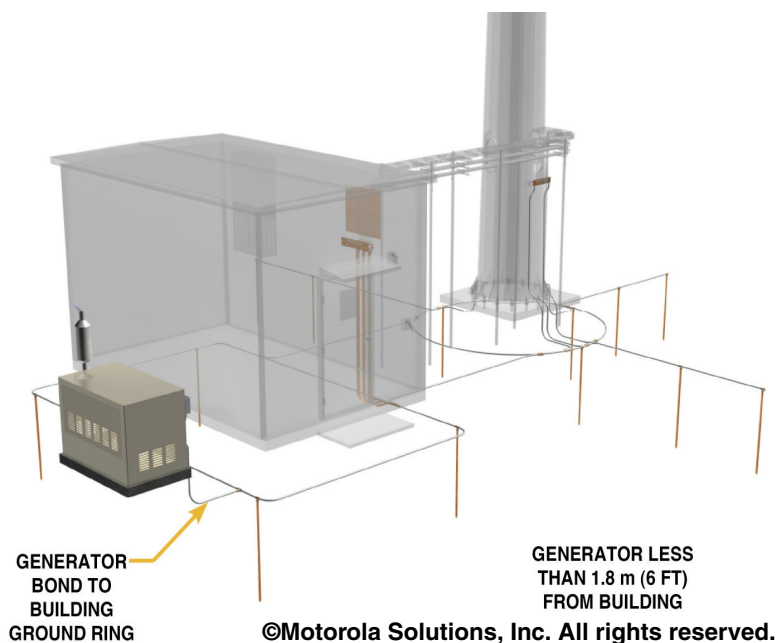

Figure 4-74 Generator Grounding: Less than 1.8 m (6 ft) from Building

Generators installed more than 1.8 m (6 ft) away from the building **shall** be bonded to the nearest practicable location on the grounding electrode system as describe previously for generators within 1.8 m (6ft) of the building. In addition, the generator **shall** have a ground rod installed nearby and bonded to the generator (ATIS-0600313.2013, Figure 3(a)) as shown in Figure 4-75. Installation of the addition generator ground rod **shall** comply with the following:

- The additional ground rod **shall** meet the requirements of “Ground Rods” on page 4-12.
- The additional ground rod **shall** be installed using methods described in “Ground Rods” on page 4-12.
- The grounding conductor between the ground rod and generator **shall** be 35 mm² csa (#2 AWG) or larger, bare, copper. The grounding conductor **shall** meet the requirements of “Grounding (Earthing), Bonding and Down-Conductors” on page 4-37.
- Bonding to the ground rod **shall** be made using exothermic welding or listed irreversible high-compression fittings. See “Bonding to the External Grounding and Bonding System” on page 4-57.

If site specific soil conditions prohibit the installation of a ground rod, other grounding electrodes appropriate for the soil conditions may be used. Such grounding electrodes may be a ground plate, a ground ring installed around the generator or a concrete-encased electrode. Refer to the specific grounding electrode section in this chapter for specifications and installation requirements.

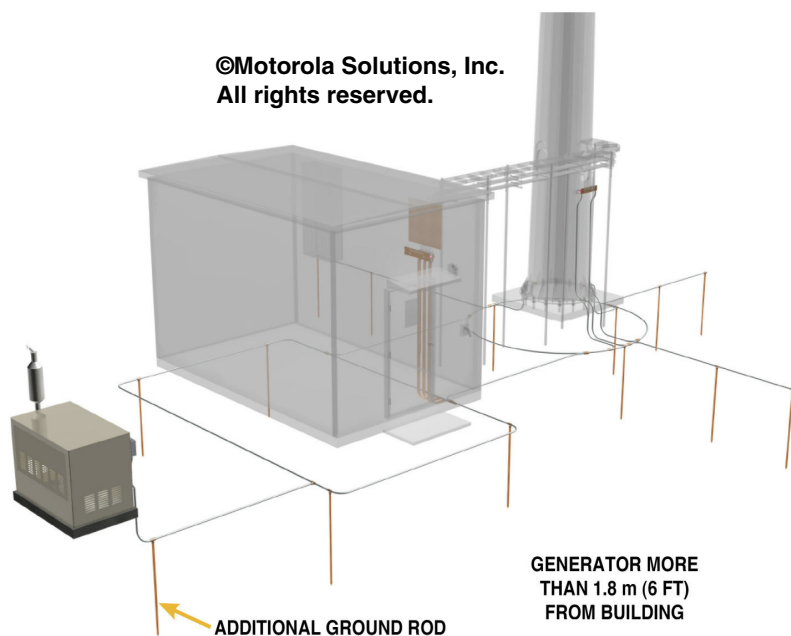

Figure 4-75 Generator Grounding: More than 1.8 m (6 ft) from Building

4.9.9 Outdoor Cabinet Grounding (Earthing) and Bonding

Outdoor cabinets are grounded in a very similar manner as a dedicated communications building or shelter (ATIS-0600313.2013, section 1.1, and TIA-607-C, section C.2.5). See “Dedicated Communications Building Grounding (Earthing)” on page 4-92 for details.

Outdoor cabinets **shall** be grounded as follows (see Figure 4-76):

- The cabinet **shall** be encircled with a ground ring. The ground ring **shall** meet the requirements according to “External Building and Tower Ground Ring” on page 4-25.
- The ground ring **shall** be installed at least 914 mm (3 ft) from the cabinet foundation/pad.
- The cabinet ground ring **shall** have a ground rod installed at each corner and as needed to limit the distance between rods from 3 m to 4.5 m (10 to 15 ft).

- The cabinet ground ring **shall** bond to the tower ground ring as detailed in “External Building and Tower Ground Ring” on page 4-25.
- Towers associated with outdoor cabinets **shall** be grounded as detailed in “Tower Grounding (Earthing)” on page 4-79.
- Generators associated with the outdoor cabinet **shall** be grounded and bonded as described in “Generators External to the Building” on page 4-93.
- RF transmission lines and other communications cables with an outer metallic shield **shall** be grounded and bonded as detailed in “Grounding and Bonding of RF Transmission Lines and Other Communications Cables” on page 4-97.
- Metallic objects near the cabinet **shall** be bonded to the cabinet grounding electrode system as detailed in “Metallic Objects Requiring Bonding” on page 4-101.
- The cabinet grounding electrode system **shall** bond to the cabinet's internal ground point and cabinet housing using a 35 mm² csa (#2 AWG) or larger, copper grounding conductor. The conductor **shall** be installed according to “Grounding (Earthing), Bonding and Down-Conductors” on page 4-37.

In addition to the requirements described previously, the following recommendations should be considered:

- Cabinets installed on pads that incorporate a footing should consider the use of concrete-encased electrodes, in addition to the ground ring. See “Concrete-Encased Electrodes” on page 4-23.
- Wire mesh should be considered for outdoor cabinet grounding where the available land for installing a traditional grounding electrode system is limited. See “Wire Mesh” on page 4-32.
- Depending on the location of the cabinet's internal ground point, the grounding conductor installed between the grounding electrode system and the cabinet's internal ground point may need to be routed through the concrete footing/ pad in order to allow conductor routing in a direct manner. This requires the grounding conductor to be installed before the concrete is poured.

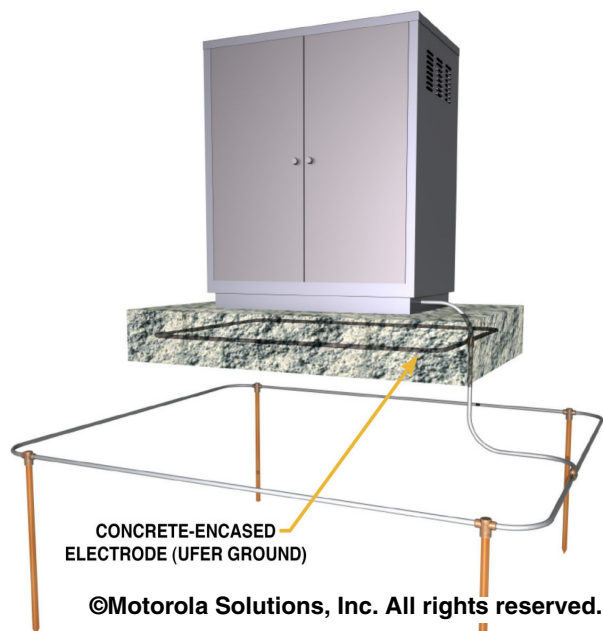

Figure 4-76 Cabinet Grounding System

4.10 Bonding of RF Preamplifiers and Other Active Devices on Tower

RF preamplifiers and other active devices are commonly installed on towers. The active devices may include, but are not limited to, the following:

- RF preamplifiers (Tower-Top Amplifier)

- Self-contained microwave radios
- Point-to-point radios
- Point-to-multi-point radios
- Wireless access points
- Wireless routers
- Video cameras

Devices installed on towers are exposed to lightning and, therefore, require special installation and grounding techniques. The device installation and grounding requirements are as follows (see Figure 4-77):

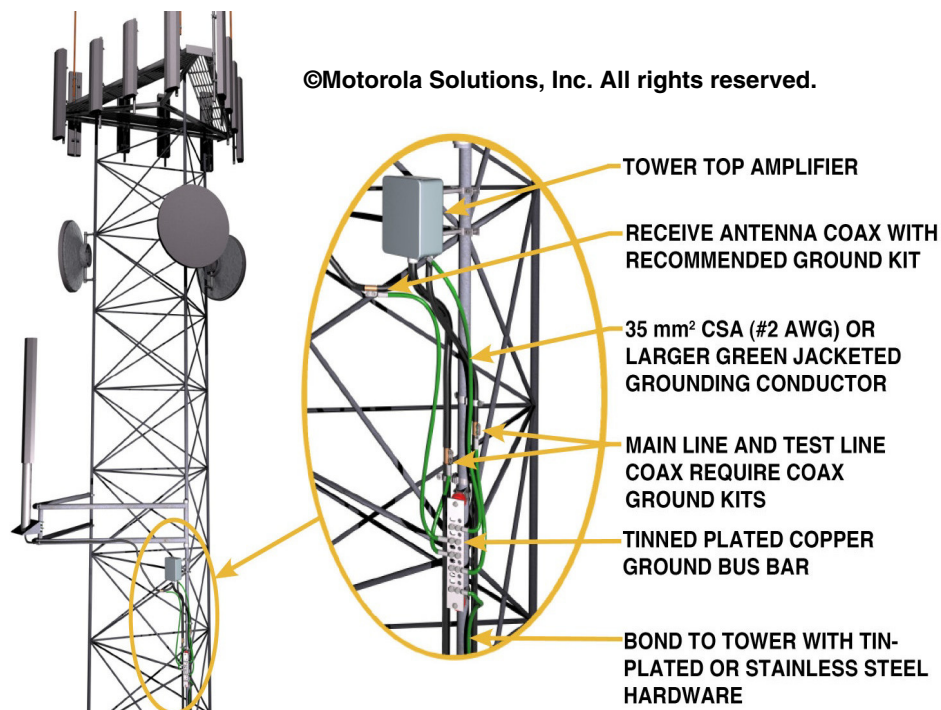

Figure 4-77 Tower-Top Amplifier Grounding/Bonding

- The device **shall** be installed and grounded according to manufacturer instructions.
- The device should not be installed on the extreme top of the tower unless protected by a lightning protection system strike termination device (or equivalent) or tower cross arm (or equivalent).
- The device **shall** be bonded to the tower structure using a 16 mm² csa (#6 AWG) tinned and/or jacketed, copper conductor. Devices that contain internal surge protective devices (such as RF preamplifiers) **shall** bond to the tower using 35 mm² csa (#2 AWG) grounding conductors. Smaller grounding conductors may be used, but only when the device cannot support a 35 mm² csa (#2 AWG) conductor.
- The grounding conductor length **shall** be no longer than necessary and **shall** flow toward earth.
- Connection to the device **shall** be made according to the manufacturer requirements.
- Connection to the tower **shall** be made using tower manufacturer-approved methods (typically a type of mechanical clamp). Connection to the tower may also include bonding to a nearby Tower Ground Bus bar (TGB).
- RF transmission lines and other device input/output cables **shall** be grounded and bonded as described in “Grounding and Bonding of RF Transmission Lines and Other Communications Cables” on page 4-97.

- RF preamplifier input transmission lines (from receive antenna) should be grounded and bonded prior to connection to the amplifier. Grounding/bonding is achieved using a ground kit (see “Grounding and Bonding of RF Transmission Lines and Other Communications Cables” and Figure 4-77). This is especially important in high-lightning environments.



NOTE

External Surge Protective Devices (SPD) associated with an active device and installed on a tower **shall** be grounded in the same manner as described previously for active devices.

4.10.1 Grounding and Bonding of RF Transmission Lines and Other Communications Cables

Transmission lines (including waveguide) and other communications cables with an outer metallic shield (such as shielded Category 5e/6/6a) **shall** be bonded to the tower in order to prevent lightning from creating a difference of potential between the tower and the cable and to help drain lightning energy to earth. A potential difference could cause arcing between the tower and the cable, resulting in damage to the cable.

See Figure 4-78 through Figure 4-81 for examples of transmission line grounding conductor attachment methods.



©Motorola Solutions, Inc. All rights reserved.

Figure 4-78 Transmission Line Ground Kit



IMPORTANT

Ground kits shall not crush or crimp the cable. Crushing or crimping the cable can negatively affect the impedance characteristics of the cable.

All transmission lines and other communications cables with an outer metallic shield **shall** be bonded to the tower using ground kits as follows:

4.10.1.1 Ground Kit General Installation Requirements

- The ground kits **shall** be designed for the type of cable. Consideration should be given to ground kits used on aluminum cables. See Figure 4-78.
- The ground kit bonding conductor **shall** be 16 mm² csa (#6 AWG) or larger.
- The ground kits **shall** be installed according to manufacturer specifications.
- The ground kits **shall not** crush, crimp or pierce the cable.
- The ground kits **shall** be sealed from the weather to prevent water and corrosion damage to the cables (ATIS-0600313.2013, section 10.5).

- The ground kits **shall** be attached to an effectively grounded vertical (or diagonal) member of the tower, using tower manufacturer-approved methods (typically a type of mechanical clamp). The ground kits may attach to a nearby tower bus bar in lieu of directly attaching to the tower structure, see “Tower Ground Bus Bar” on page 4-46. See Figure 4-79 through Figure 4-81 for examples of methods used to attach directly to the tower. (ATIS-0600313.2013, section 10.5)
- The ground kit grounding conductors **shall** be installed without drip loops, parallel to the cable and pointed down toward the earth to provide a direct discharge path for lightning (ATIS-0600313.2013, section 10.5.1). All bends **shall** be gradual and sweeping to minimize inductance (ATIS-0600313.2013, section 10.5).

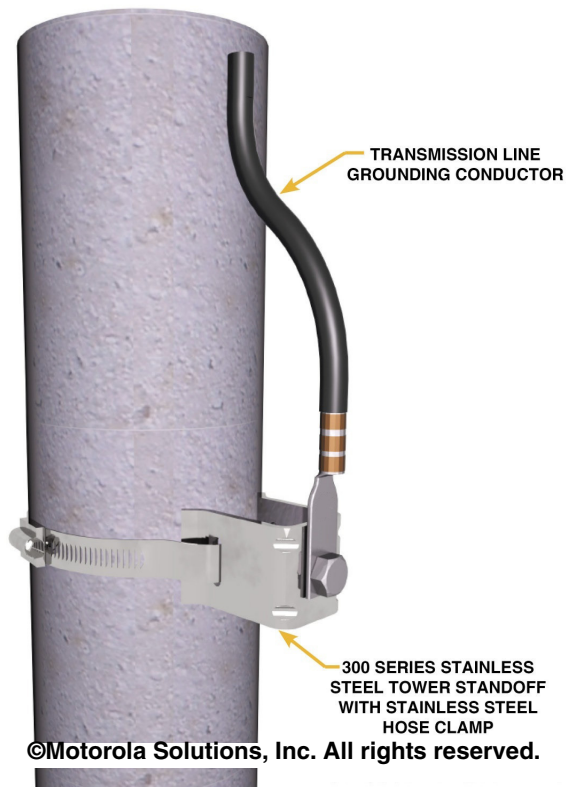

Figure 4-79 Grounding Transmission Line Top and Middle (Tubular Tower)

4.10.1.2 Ground Kit Location

- See Figure 4-82 and Figure 4-83.
- Ground kits **shall** be installed near the top of the vertical run (which is the top of the main line for coax and waveguide), near the antenna or device (ATIS-0600334.2013, section 6.6; ATIS-0600313.2013, section 10.5.1; and IEEE 1692-2011, section 8.7).
- A ground kit should be installed on the input coax (from receive antenna) to a tower-top amplifier. See Figure 4-77.
- Ground kits **shall** be installed at the bottom of the tower above the vertical-to-horizontal transition point (ATIS-0600313.2013, section 10.5.1; ATIS-0600334.2013, section 6.6; and IEEE 1692-2011, section 8.7).
- If the tower is greater than 61 m (200 ft) in height, an additional ground kit **shall** be installed at the tower midpoint (ATIS-0600334.2013, section 6.6). Additional ground kits (equally spaced) **shall** be installed as necessary to reduce the distance between ground kits to 61 m (200 ft) or less.
- In high lightning activity areas, ground kits should be installed at spacing between 15.2 to 22.9 m (50 to 75 ft) (ATIS-0600313.2013, section 10.5.1; ATIS-0600334.2013, section 6.6; and IEEE 1692-2011, section 8.7).

**IMPORTANT**

In high lightning activity areas, ground kits should be installed every 15.2 to 22.9 m (50 to 75 ft).



Figure 4-80 Grounding Transmission Line Top And Middle (Angular Tower)

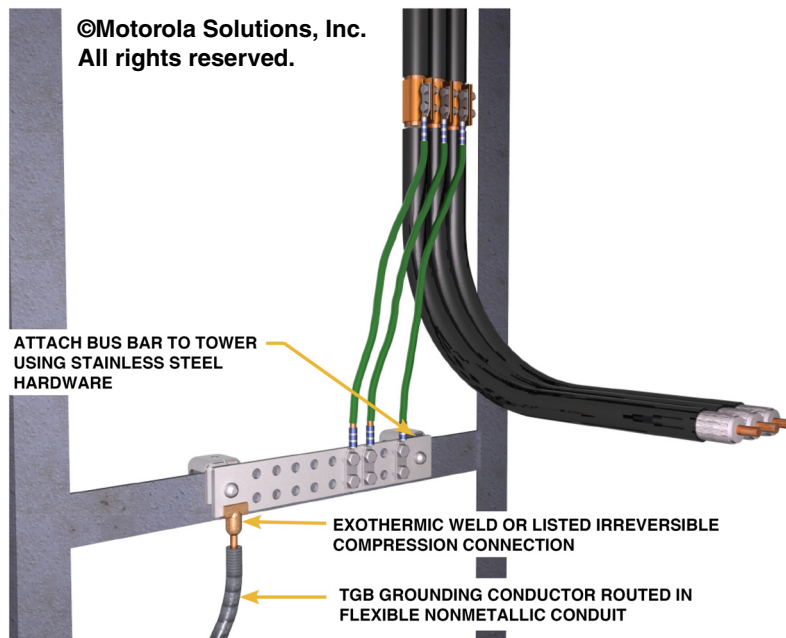

Figure 4-81 Bus Bar Configuration, Bottom Ground Kit on Angular Tower (Weatherproofing Not Shown)

- Ground kits **shall** be installed near the building, shelter, equipment housing or cabinet entry point (ATIS-0600313.2013, section 10.5.3; ATIS-0600334.2013, section 6.6; MIL-HDBK-419A; and NFPA 70-2017, Articles 800.100, 810.20, 810.21, 820.93, 830.93 and 830.100). The ground kits **shall** bond to the External Ground Bus bar (EGB) if installed or directly to the grounding electrode system, ensuring a continuous downward flow toward the grounding electrode system is maintained.

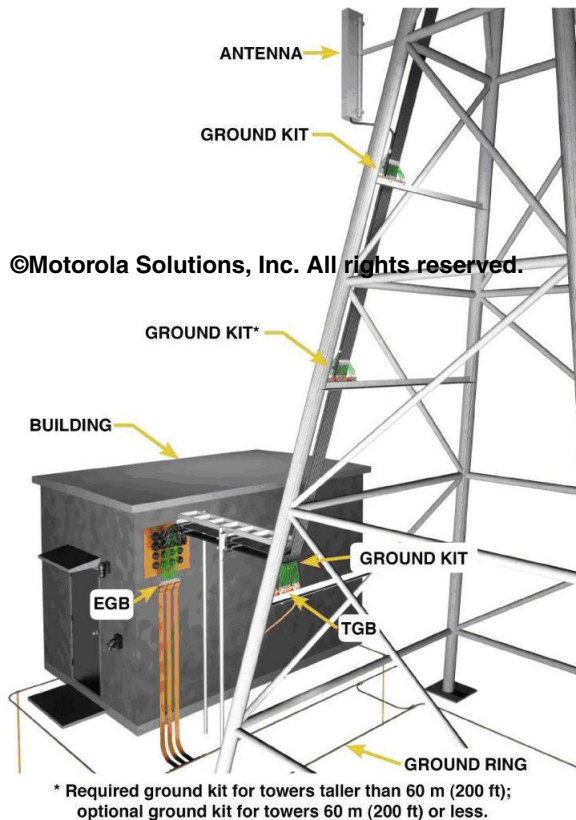

Figure 4-82 Location of Transmission Line Grounding Kits

NOTE

The use of down-conductors on metallic towers is not recommended for grounding/bonding transmission lines, other communications cables and lightning rods. A down-conductor has much higher impedance to earth than the tower structure. The use of down-conductors does not provide equal-potential bonding between the transmission lines/communications cables and tower.

NOTE

Communications cables installed on a wooden pole (and other non-metallic) structure **shall** bond to the wooden pole vertical grounding conductor in the same manner as described previously. See Figure 4-72.

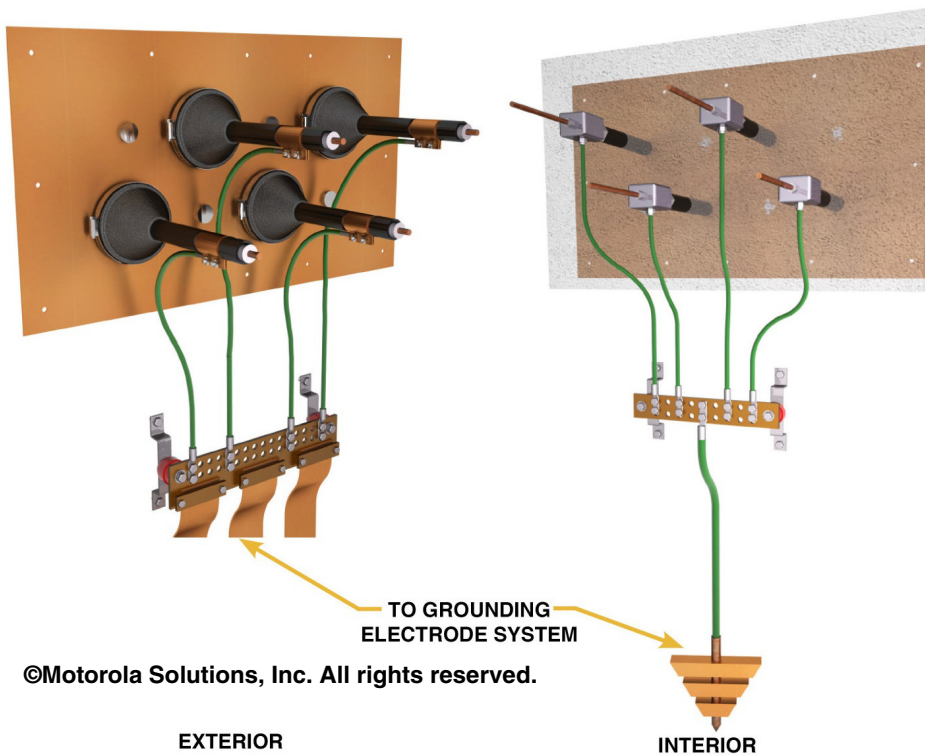

Figure 4-83 Transmission Line Grounding At Building Entry Point (Weatherproofing Not Shown)

4.10.2 Metallic Objects Requiring Bonding

The objective of bonding metallic objects is to equalize the potential between conductive parts. This is done for personnel safety and to prevent arcing between metallic components that might otherwise be at different potentials. Bonding conductors **shall** be as short and straight as practicable. See ATIS-0600313.2013, section 6.3.

Metallic objects that are located within 1.8 m (6 ft) of the external grounding electrode system or within 1.8 m (6 ft) of a grounded metallic item, **shall** be bonded to the external grounding electrode system using 16 mm² csa (#6 AWG) or larger conductors as described in “Grounding (Earthing), Bonding and Down-Conductors” on page 4-37 (ATIS-0600334.2013, section 5.3.3). Bonding to the metallic objects **shall** be made as allowed by the manufacturer. In high lightning prone geographical areas or areas of high soil resistivity, it is recommended to bond all metallic objects that are located within 3 m (10 ft) of the external grounding electrode system or within 3 m (10 ft) of a grounded metallic item (ATIS-0600313.2013, section 10.3.2). See “Bonding to the External Grounding and Bonding System” on page 4-57 for more information.

Metallic objects requiring bonding include, but are not limited to, the following items (see ATIS-0600313.2013, section 10.3.2, and ATIS-0600334.2013, section 5.3.3.)

- Cable Bridge/Ice Bridge (see “Cable Bridge/Ice Bridge Grounding (Earthing) and Bonding” on page 4-108)
- External light fixtures or support masts
- Fences: fabric, gates and posts (see “Fence And Gate Grounding (Earthing) and Bonding” on page 4-102 for specific fence and gate grounding/bonding requirements)
- Fuel storage tanks (above and below grade). See “Fuel Tank Bonding” on page 4-112.
- Generator frame. See “Generators External to the Building” on page 4-93.
- Hand rails
- HVAC units
- Metallic conduits, piping and raceways. See “Metallic Piping Bonding” on page 4-111.

- Metallic entry ports
- Metallic members of all incoming telecommunications cables, including paired-conductor and optical fiber (ATIS-0600313.2013, section 8.2)
- Other grounding electrodes or electrode systems at the site (see “Common Grounding” on page 4-6)
- Skid plate, anchor plate or metal support frame of a prefabricated shelter
- Solar photovoltaic system (and other alternate sources of power) supports and conduits. See “Solar Photovoltaic Systems” on page 4-113.
- Telephone service provider ground (if external)
- Vent covers (if not already bonded inside)



IMPORTANT

Do not bond electrically continuous items (such as unused entry panels) if they are already bonded inside to the internal bonding and grounding system. Bonding on both sides can compromise the single-point ground concept at the site.



NOTE

Bonding conductors installed below grade **shall** be 35 mm² csa (#2 AWG) or larger. See “Grounding (Earthing), Bonding and Down-Conductors” on page 4-37.

4.10.2.1 Fence And Gate Grounding (Earthing) and Bonding

Fences and gates are grounded and bonded to protect personnel from touch potential hazards and from step potential that can be generated during lightning activity or during a fault of the utility or facility electrical system (see NWSM 30-4106, section 2.7.10). All metallic fences and gates within 6.1 m (20 ft) of a communications shelter/building **shall** be grounded and bonded to the facility’s common grounding electrode system (see NWSM 30-4106-2005, section 2.7.10, and FAA STD-019e, section 4.2.3.8, for more information).

Fences and gates that are beyond 6.1 m (20 ft) from the communications shelter/building but are within 1.8 m (6 ft) from the grounding electrode system (such as the building ground ring, tower ground ring or radial grounding conductors) or other grounded metallic items **shall** be bonded to the facility’s common grounding electrode system. Bonding **shall** be made using techniques described in this section.

Where fences are located at an electrical power substation, the fence grounding **shall** be made as required by the *National Electrical Safety Code*[®], IEEE STD 80 and by the electric utility.

Fences and gates around tower guy anchor points **shall** be bonded to the guy anchor ground rod using techniques as described in this section.

A fence grounding system for a typical communications site is shown in Figure 4-84.



NOTE

If the site contains fencing that extends well beyond the communications site (for example, where the communications site is within a large compound), the entire compound fence is not required to be grounded and bonded. Only those portions of the fence that are within 6.1 m (20 ft) of the communications building and/or tower or are within 1.8 m (6 ft) of a grounded object are required to be grounded and bonded.



NOTE

Only commercial-grade fencing **shall** be used at a communications site. Residential-grade fencing **shall not** be used.

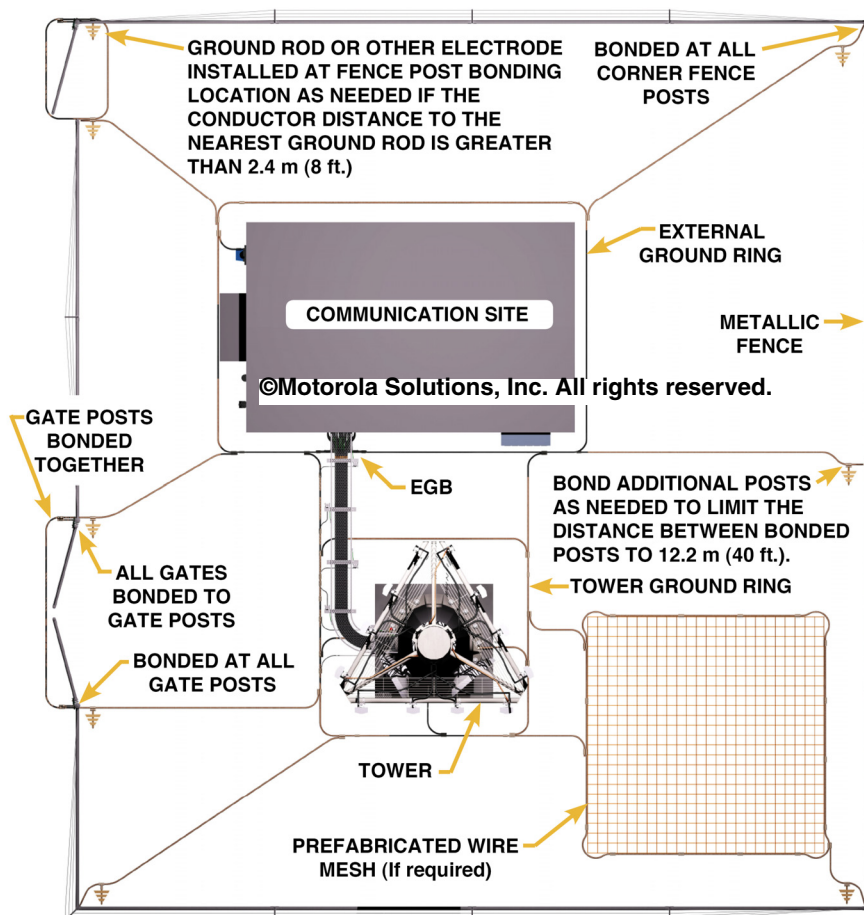

Figure 4-84 Example of Fence Grounding and Bonding

The grounding/bonding requirements for fence systems installed within 6.1 m (20 ft) of the communications building/shelter are as follows:

4.10.2.1.1 Fence Post Grounding/Bonding

- Each corner fence post **shall** be bonded to the nearest location of the building or tower ground ring using 35 mm² csa (#2 AWG) or larger, bare, copper conductors (ATIS-0600313.2013, Figure 3(a)). If the bonding connection to the fence post uses mechanical hardware, tinned-copper conductors **shall** be used.
 - If the site fencing extends well beyond the communications site (for example, where the communications site is within a large compound), the first fence posts that extend beyond 6.1 m (20 ft) from the communications building and/or tower should be used instead of the distant corner post.
- Additional fence posts **shall** be bonded as needed to limit the distance between bonded posts to 12.2 m (40 ft) (FAA-STD-019e, section 4.2.3.8, and NWSM 30-4106, section 2.7.10.1).
- Connection to the fence post **shall** use exothermic welding, where practicable; otherwise listed mechanical hardware designed for the purpose may be used. If the bonding connection to the fence post uses mechanical hardware, tinned-copper conductors **shall** be used. See “Above-Grade Mechanical Lugs and Connection Devices” on page 4-58 for more details.
- Connection to the fence post **shall** be made at a height no greater than 305 mm (1 ft) above finished grade (FAA-STD-019e, section 4.2.3.8, and NWSM 30-4106, section 2.7.10.1).

- The grounding conductors **shall** be buried to the same depth as the building ground ring, where practicable. See ATIS-0600313.2013, Figure 3(a).
- A ground rod (or other electrode) **shall** be installed at the post bonding locations if the conductor distance to the nearest rod (or other electrode) is greater than 2.4 m (8 ft). See NWSM 30-4106 and FAA STD-019e for more information.
- See Figure 4-84 and Figure 4-85.

4.10.2.1.2 Fence Fabric Grounding/Bonding

- The fence fabric near each post bonding point **shall** be bonded to the nearest location of the building or tower ground ring using 35 mm² csa (#2 AWG) or larger, bare, tinned, copper conductors. This bond should be made using the same grounding conductor used for bonding the fence post. See TIA-607-C, section C.2.8.1, for additional information.
- The fence fabric bond **shall** be made near the top, middle and bottom of the fabric as shown in Figure 4-85. Ensure all fence fabric bonds are to different fence fabric strands. Depending on the fence fabric construction, this may require the bonding conductor to be installed at a slight angle. See TIA-607-C, Figure 38, for more information.

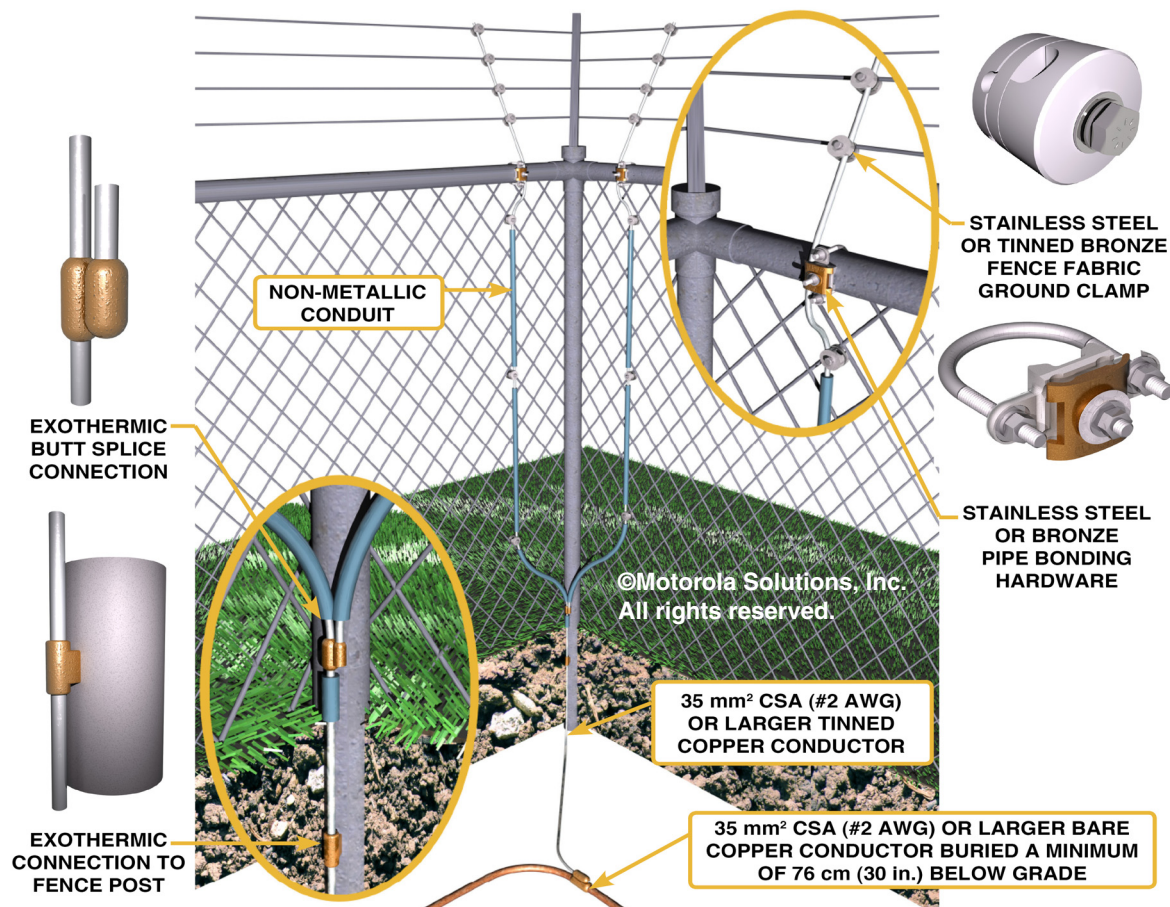

Figure 4-85 Example of Fence Fabric and Deterrent Wiring Bonding

- Clamps used for fence fabric bonding **shall** be designed for the purpose and **shall** be constructed from tinned-copper, tinned-copper alloy or stainless steel. See “Above-Grade Mechanical Lugs and Connection Devices” on page 4-58 for more details.
- The grounding conductor **shall** be routed so as to not come into incidental contact with the deterrent wiring, fence post, fence fabric or support apparatus for the wire. Incidental contact can create an RF interference point.

**NOTE**

Vinyl coated fence fabric is not recommended. If used, vinyl coated fence fabric does not require bonding.

**IMPORTANT**

Ensure all fence fabric bonds are to different fence fabric strands. Depending on the fence fabric construction, this may require the bonding conductor to be installed at a slight angle.

4.10.2.1.3 Entry Deterrent Wiring Grounding/Bonding

See Figure 4-85 and Figure 4-86 for examples.

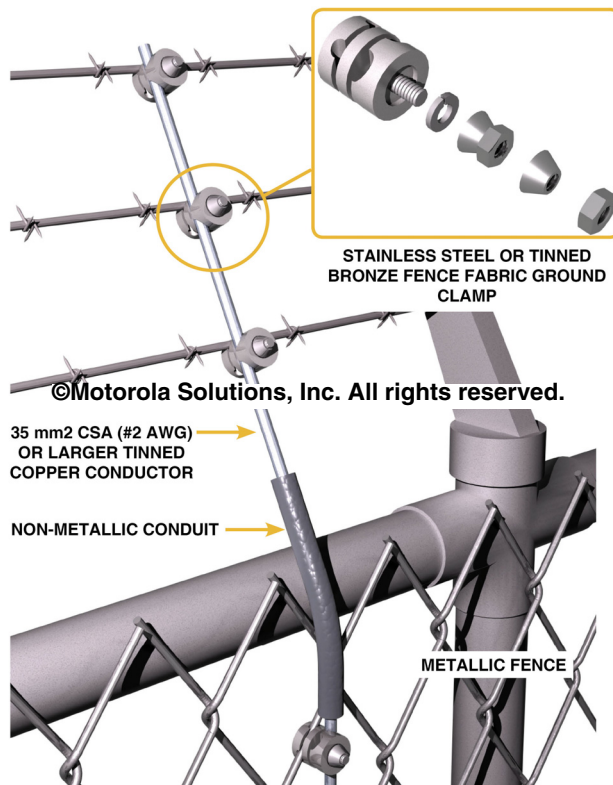

Figure 4-86 Deterrent Wire Bonding

If the site fence has non-electrified entry deterrent wiring (security wire) and the fence is required to be grounded/bonded as described previously, the entry deterrent wiring **shall** be grounded and bonded as follows:

- The deterrent wiring near each fence post bonding point **shall** be bonded to the nearest location of the building or tower ground ring using 35mm² csa (#2 AWG) or larger, bare, tinned, copper conductor. This bond should be made using the same grounding conductor used for bonding the fence fabric.
- Clamps used for security wire bonding **shall** be designed for the purpose and **shall** be constructed from tinned-copper, tinned-copper alloy or stainless steel. See “Above-Grade Mechanical Lugs and Connection Devices” on page 4-58 for more details.
- The grounding conductor **shall** be routed so as to not come into incidental contact with the deterrent wiring, fence post, fence fabric or support apparatus for the wire. Incidental contact can create an RF interference point.

- The grounding conductor **shall** follow the proper routing methods described in “Bending and Routing Grounding (Earthing), Bonding and Down-Conductors” on page 4-38.

4.10.2.1.4 Gate Grounding/Bonding

- Gate posts **shall** be bonded together with a buried 35mm² csa (#2 AWG) or larger, bare, copper conductor.
- Gate posts (on both sides of the gate) **shall** be bonded to the nearest location of the building or tower ground ring using 35 mm² csa (#2 AWG) or larger, bare, copper conductors (ATIS-0600313.2013, Figure 3(a) and the *National Electrical Safety Code*[®]).
- Connection to the gate post **shall** use exothermic welding, where practicable; otherwise listed mechanical hardware designed for the purpose may be used (see “Above-Grade Mechanical Lugs and Connection Devices” on page 4-58 for more details). If the bonding connection to the gate post uses mechanical hardware, tinned-copper conductors **shall** be used.
- Connection to the gate post **shall** be made at a height no greater than 305 mm (1 ft) above finished grade (FAA-STD-019e, section 4.2.3.8, and NWSM 30-4106, section 2.7.10.1).
- The grounding conductors **shall** be buried to the same depth as the building ground ring where practicable. See ATIS-0600313.2013, Figure 3(a).
- See Figure 4-87 for an example.

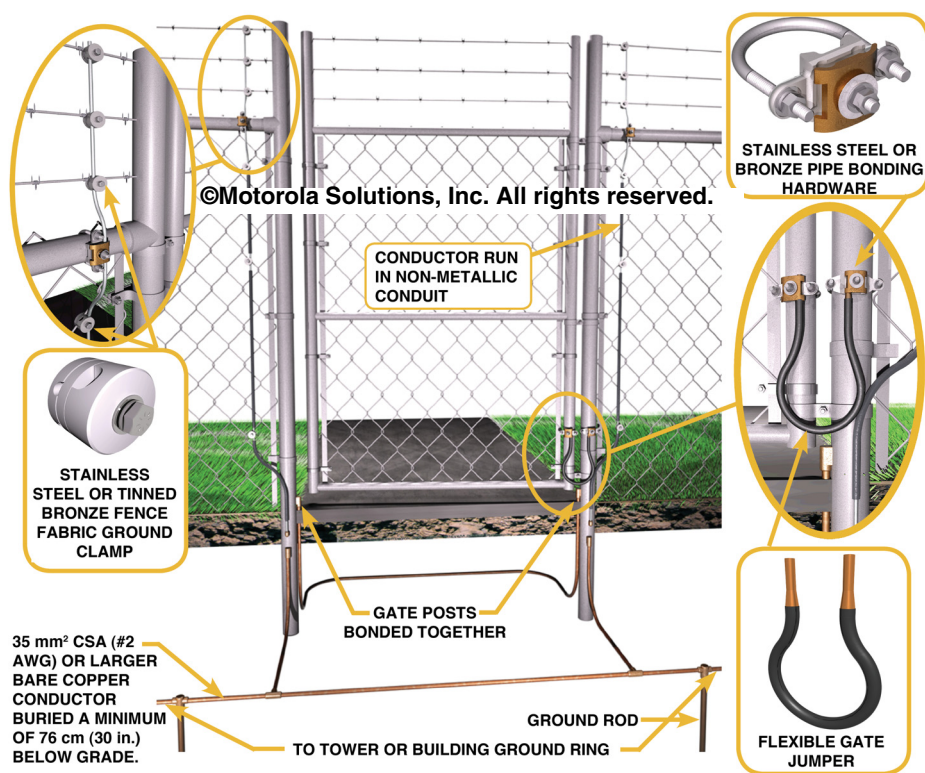

Figure 4-87 Example of Gate Bonding

- The gate **shall** be bonded to the gate supporting post with a 16 mm² csa (#6 AWG) or larger, jacketed, stranded, copper bonding jumper. This jumper wire should be constructed with a highly flexible conductor (ATIS-0600313.2013, Figure 3(a)), such as 133-strand. The gate bonding jumper **shall** be installed so as not to limit full motion of the gate (NWSM 30-4106, section 2.7.10.1). The jumper **shall** be installed in an S-shape pattern, unless this restricts full movement of the gate. Otherwise, a U-shaped pattern can be used.

- The gate bonding jumper **shall** bond to the gate and post using exothermic welding, where practicable; otherwise listed mechanical hardware designed for the purpose may be used (see “Above-Grade Mechanical Lugs and Connection Devices” on page 4-58 for more details).



IMPORTANT

Braided straps shall not be used because they corrode easily and can become a point for RF interference.

4.10.2.1.5 Fences Crossed by Overhead Power Lines

Where overhead power lines (all voltages) cross over a communications site metallic fence, the following additional grounding/bonding **shall** be completed to help ensure that, in the event the live electrical power lines fall on the fence, the fence will remain at ground potential (see FAA-STD-019e, section 4.2.3.8.3, and NSWM 30-4106, section 2.7.10.2):

- See Figure 4-88 for grounding and bonding requirements.

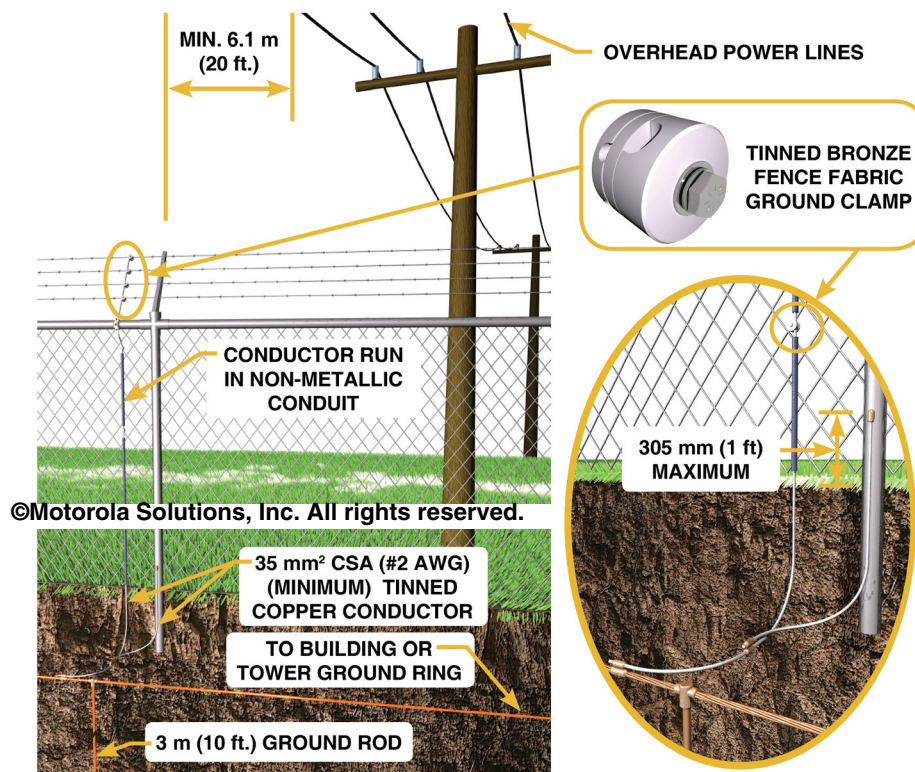

Figure 4-88 Grounding and Bonding for Fences Crossed by Overhead Power Lines (One Side of Overhead Power Lines Shown)



NOTE

The requirements in this subsection are in addition to the fence and gate grounding and bonding requirements described previously.

- A fence post on each side of the overhead wire crossing **shall** be bonded to the grounding electrode system using methods described in “Fence And Gate Grounding (Earthing) and Bonding” on page 4-102.
- The bond to the post **shall** be on each side and at least 6.1 m (20 ft) and no more than 12.2 m (40 ft) from the overhead wire crossing.

- A 3 m (10 ft) ground rod **shall** be installed at each bond location. If soil conditions do not permit driving a ground rod, other electrodes appropriate for the soil conditions may be used.
- The fence fabric at each post bonding location **shall** be bonded at the top, middle and bottom using methods described in “Fence Fabric Grounding/Bonding” on page 4-104.
- The security wire (each strand) at each post bonding location **shall** be bonded using methods described in “Fence And Gate Grounding (Earthing) and Bonding” on page 4-102.

4.10.2.2 Cable Bridge/Ice Bridge Grounding (Earthing) and Bonding

Cable bridges and ice bridges are used to protect and support RF transmission lines (and other communications cables) between the tower structure and the equipment building/shelter. Where present, cable bridges and ice bridges **shall** be bonded to the grounding electrode system.

4.10.2.2.1 Self-Supported Cable Bridge/Ice Bridge

Grounding and bonding of **self-supported** cable bridges/ice bridges **shall** be completed as follows (see Figure 4-89):

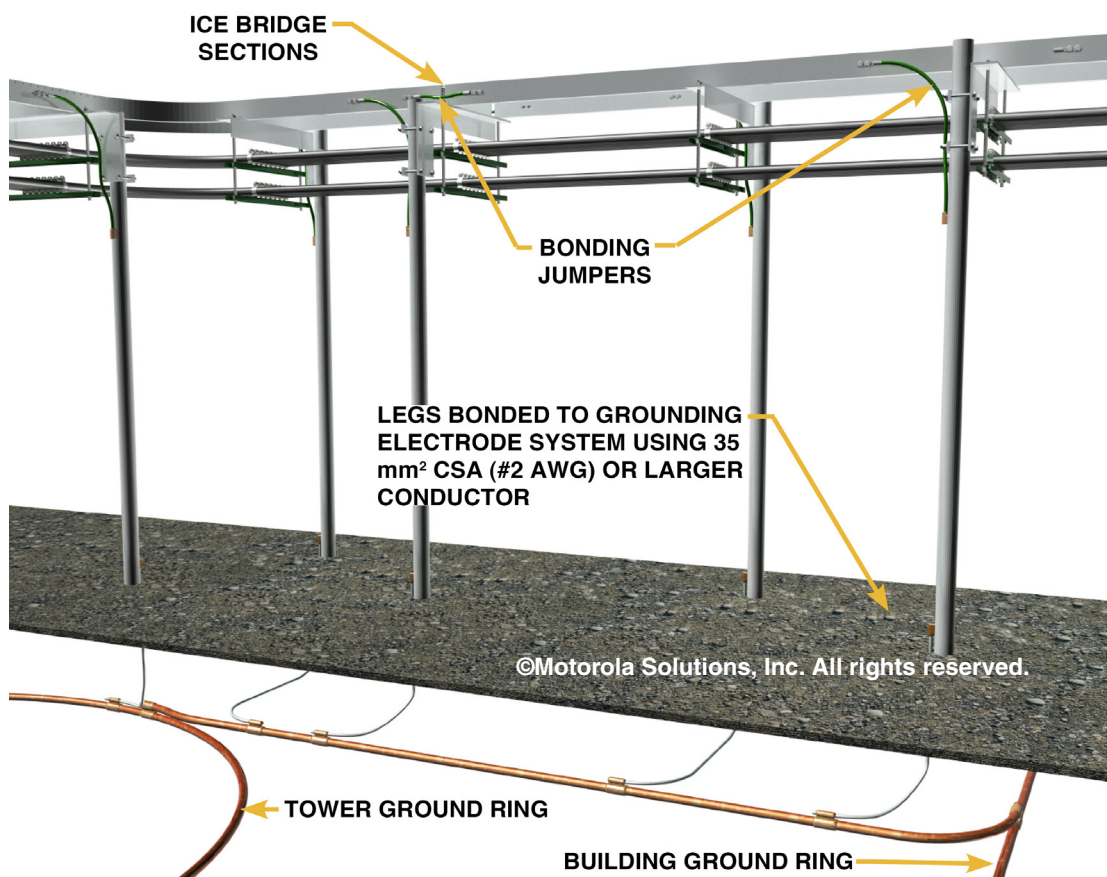

Figure 4-89 Proper Grounding of Self-Supporting Ice Bridge

- Each support post **shall** be bonded to the grounding electrode system using a 35 mm² csa (#2 AWG) or larger, bare copper conductor.
- Conductor bonding to the grounding electrode system **shall** be made using exothermic welding or listed irreversible high-compression fittings. See “Bonding to the External Grounding and Bonding System” on page 4-57.

- Conductor bonding to the support posts **shall** be made using exothermic welding. See “Bonding to the External Grounding and Bonding System” on page 4-57.
- To help ensure effective bonding, the cable bridge/ice bridge should be bonded to each support post using a 16 mm² csa (#6 AWG) or larger, jacketed (ATIS-0600334.2013, section 5.1), copper conductor (bonding jumper). Conductor bonding to the support post **shall** be made using exothermic welding. Conductor bonding to the cable bridge/ice bridge **shall** be made using exothermic welding or listed two-hole lugs and stainless steel hardware (see “Above-Grade Mechanical Lugs and Connection Devices” on page 4-58 and “Securing Hardware” on page 4-61 for specific requirements).
- If more than one span of cable bridge/ice bridge is used between the tower and building, bonding jumpers should be installed between the sections to help ensure effective bonding. The bonding jumpers **shall** be a 16 mm² csa (#6 AWG) or larger, jacketed, copper conductor. The bonding jumpers should use listed two-hole lugs and stainless steel hardware (see “Above-Grade Mechanical Lugs and Connection Devices” on page 4-58 for specific requirements).

4.10.2.2.2 Tower and/or Building Supported Cable Bridge/Ice Bridge

The cable bridge/ice bridge **shall** bond to the grounding electrode system. Grounding and bonding of tower and/or building supported cable bridges/ice bridges **shall** be completed as follows:

4.10.2.2.2.1. At the Building

- Bonding to the grounding electrode system may be accomplished using a 16 mm² csa (#6 AWG) or larger, copper conductor bonded to the External Ground Bus bar (EGB). Conductor bonding to the cable bridge/ice bridge and EGB **shall** be made using exothermic welding or two-hole lugs and stainless steel hardware. See “Bonding to the External Grounding and Bonding System” on page 4-57.
- Bonding of the cable bridge/ice bridge to the grounding electrode system may also be accomplished using a 35 mm² csa (#2 AWG) or larger, bare, copper conductor bonded directly to the grounding electrode system.
 - Conductor bonding to the grounding electrode system **shall** be made using exothermic welding or listed irreversible high-compression fittings.
 - Conductor bonding to the cable bridge/ice bridge **shall** be made using exothermic welding or listed two-hole lugs and stainless steel hardware. The grounding conductor should be installed in a flexible non-metallic conduit to help prevent incidental contact with other metals, allow for protection of the conductor and help support the conductor. See “Bonding to the External Grounding and Bonding System” on page 4-57.



IMPORTANT

Do not bond the cable bridge/ice bridge directly to the cable entry port. Doing so would provide a discharge path for lightning into the building. See IEEE 1692-2011, section 9.2.

4.10.2.2.2.2. At the Tower

- Cable bridges/ice bridges may be sufficiently grounded when they are an integral part of the tower construction and are bonded directly to the tower through multiple metallic mechanical connections. The metallic connections **shall** be of the same metals and **shall** provide direct metal-to-metal contact without non-conductive coatings, such as paint.
- When the cable bridge/ice bridge is not effectively bonded to the tower, additional bonding **shall** be required in order to effectively ground the cable bridge/ice bridge. The additional bonding **shall** be accomplished using one of the following techniques:
 - Installing a 16 mm² csa (#6 AWG) or larger, copper conductor (bonding jumper) between the cable bridge/ice bridge and the tower. Conductor bonding to the cable bridge/ice bridge **shall** be made using exothermic welding or listed two-hole lugs and stainless steel hardware.
 - Conductor bonding to the tower **shall** be made using exothermic welding (to a tower manufacturer approved location) or other suitable hardware. See “Bonding to the External Grounding and Bonding System” on page 4-57.

- Installing a 16 mm² csa (#6 AWG) or larger, copper conductor (bonding jumper) between the cable bridge/ice bridge and the nearby Tower Ground Bus bar (TGB). Conductor bonding to the cable bridge/ice bridge and TGB **shall** be made using exothermic welding or listed two-hole lugs and stainless steel hardware. See “Bonding to the External Grounding and Bonding System” on page 4-57.
- Installing a 35 mm² csa (#2 AWG) or larger, bare copper conductor bonded directly to the grounding electrode system. Conductor bonding to the grounding electrode system **shall** be made using exothermic welding or listed irreversible high-compression fittings. Conductor bonding to the cable bridge/ice bridge **shall** be made using exothermic welding or listed two-hole lugs and stainless steel hardware. The grounding conductor should be installed in a flexible non-metallic conduit to help prevent incidental contact with other metals and to help protect and support the conductor.



NOTE

In order to reduce the amount of lightning energy diverted toward the equipment building/shelter and to provide seismic isolation between the building and tower, it is recommended to secure the cable bridge/ice bridge to the tower through a non-conductive slip-joint type device. Where a slip-joint type device is used, grounding of the cable bridge/ice bridge at the building **shall** be completed as described previously; grounding at the tower end of the cable bridge/ice bridge **shall** be completed as shown in Figure 4-90. See IEEE 1692-2011, section 9.2.

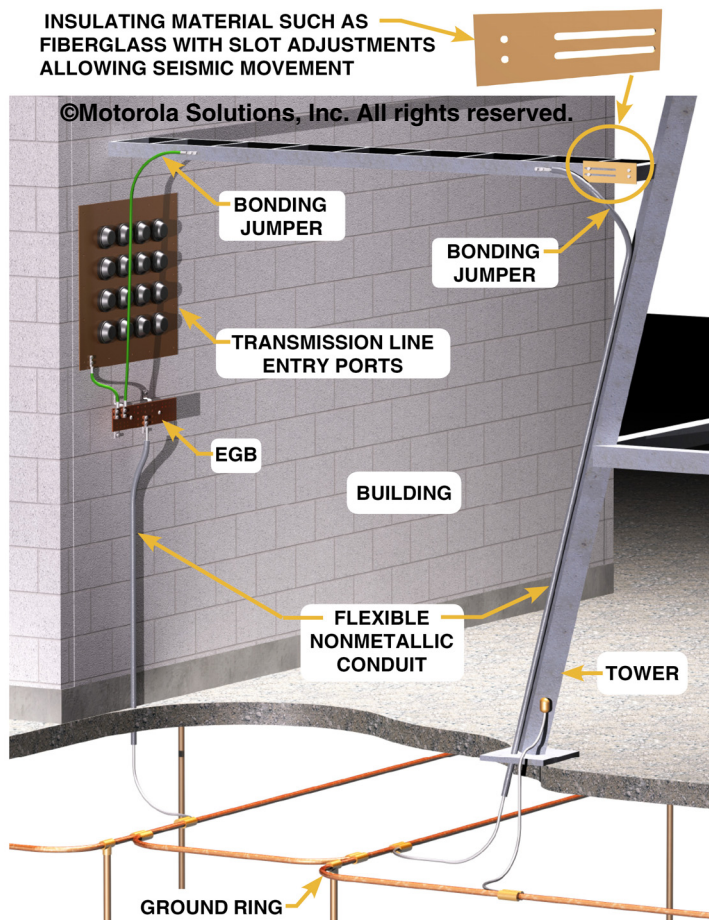

Figure 4-90 Proper Grounding of Non-Self-Supporting Ice Bridge



IMPORTANT

In ice prone areas, if isolating the cable bridge/ice bridge from the tower creates an unprotected area on the RF transmission lines (or other communications cables), some type of ice shield shall be installed above the isolation point in order to protect the RF transmission lines. The ice shield shall be bonded to the tower only.

4.10.2.3 Metallic Building Siding Bonding

Although metallic building siding is not required to be bonded by this standard, grounding the metallic siding can provide additional safety at the site (NFPA 70-2017, Article 250.116 Informational Note). It is recommended to bond the metallic building siding in at least one location on the building, preferably near the electrical service entrance.

4.10.2.4 Metallic Piping Bonding

Lightning energy can enter a communications facility via any available conductive path. To help prevent lightning and other electrical surges from entering the facility, all metallic piping and conduits **shall** be bonded to the grounding electrode system as near as practicable to the entry location to the facility (see BS 7430:2011, Clause 6.4). This is typically accomplished using a 35 mm² csa (#2 AWG) grounding conductor bonded directly to the grounding electrode system. See Figure 4-91 for bonding examples.



Figure 4-91 Examples of Metallic Pipe Grounding

4.10.3 Fuel Tank Bonding

4.10.3.1 Above-Grade Pressurized Tanks

Above-grade pressurized fuel tanks (for example, propane and compressed natural gas) **shall** be bonded to the grounding electrode system as described in “Metallic Objects Requiring Bonding” on page 4-101. This is typically accomplished by attaching a bonding conductor to a tank manufacturer approved location (such as a support leg) using a two-hole lug with stainless steel hardware, approved mechanical hardware (see “Above-Grade Mechanical Lugs and Connection Devices” on page 4-58) or exothermic weld (prior to filling the tank) (see FAA-STD-019e, section 4.2.3.3.4). See Figure 4-92 and Figure 4-93 for examples.



Figure 4-92 Example of Above-Ground Propane Tank Grounding



Figure 4-93 Detail From Example of Above-Ground Propane Tank Grounding

4.10.3.2 Above-Grade Non-Pressurized Tanks

Above-grade non-pressurized metallic fuel tanks, such as those for liquid fuels such as diesel or gasoline, that are electrically continuous; tightly sealed to prevent the escape of liquids, vapors or gases; and of 4.8 mm (3/16 in.) thickness or greater are considered to be inherently self-protecting and only require bonding to the grounding electrode system (see IEEE 142-2007, section 3.3.4.2, and NFPA 780-2017, section 7.2.2). Above-grade non-pressurized tanks **shall** be bonded to the grounding electrode system as described in “Metallic Objects Requiring Bonding” on page 4-101. This is typically accomplished (prior to filling the tank) by attaching a bonding conductor to a tank manufacturer-approved location (such as a support leg) using a two-hole lug with stainless steel hardware, approved mechanical hardware (see “Above-Grade Mechanical Lugs and Connection Devices” on page 4-58) or exothermic weld to a dedicated grounding location (prior to filling the tank).

Tanks that do not meet the above construction requirements **shall** require lightning protection as defined in NFPA 780 or other lightning protection standard in effect and recognized by the Authority Having Jurisdiction. See FAA-STD-019e, section 4.2.3.3.4, for more information.

4.10.3.3 Below-Grade Tanks

Below-grade fuel tanks **shall** meet the construction requirements of applicable codes (such as NFPA 30 and 58) and the Authority Having Jurisdiction (AHJ). Below-grade fuel tanks **shall** meet the installation requirements of the tank manufacturer, applicable codes (such as NFPA 30 and 58) and the AHJ. Below-grade metallic fuel tanks **shall** be protected from corrosion with a cathodic protection system or other system approved by the tank manufacturer and the AHJ (see NFPA 30-2015, section 23.3.5, and NFPA 58-2017, Annex K, for more information).

Below-grade fuel tanks are **not** required to be bonded to the site grounding electrode system if no part of the tank is exposed. If any metallic part of the tank (including the piping system and monitoring system) is exposed, the tank **shall** be bonded to the grounding electrode system as described in “Metallic Objects Requiring Bonding” on page 4-101.

Metallic piping systems associated with the tank **shall** be bonded to the site grounding electrode system as near as practicable to the entry location to the facility. See “Metallic Piping Bonding” on page 4-111.

4.10.4 Solar Photovoltaic Systems

Solar photovoltaic (PV) systems **shall** be grounded according to the Authority Having Jurisdiction (see Chapter 6, “Power Sources”, and NFPA 70-2017, Article 690 for grounding requirements).

Exposed non-current carrying metal parts of PV module frames, electrical equipment and conductor enclosures **shall** be bonded to the site grounding electrode system (NFPA 70-2017, Article 690.43) using appropriate hardware (see “Above-Grade Mechanical Lugs and Connection Devices” on page 4-58).

Metallic support posts and mounts **shall** be bonded to the common grounding electrode system according to “Metallic Objects Requiring Bonding” on page 4-101 (ATIS-0600334.2013, section 5.3.3). See Figure 4-94.



Figure 4-94 Solar Photovoltaic Grounding

**NOTE**

Ground other alternate power sources, such as wind generators, in a manner similar to that described in this section for solar photovoltaic systems.

4.11 Grounding Roof-Mounted Antenna Masts and Metal Support Structures

All roof-mounted antenna masts and metal support structures **shall** be grounded (NFPA 70-2017, Article 810.15). See TIA-607-C, section C.2.6, for more information.

**NOTE**

Rooftop mounted towers are not covered in this section. See “Grounding (Earthing) Rooftop Mounted Tower Structures” on page 4-119 for information about rooftop tower grounding requirements.

In new construction, provisions should be engineered into the building design for effective roof-mounted antenna mast and support structure grounding. Typically this will include a grounding point or multiple grounding points, with at least two direct connections to the building's common grounding electrode system. The direct connection to the building's grounding electrode system may be made using effectively grounded structural building steel (metal frame/framework) (preferred) and/or down-conductors sized according to Table 4-5 or lightning protection system conductors sized according to Table 4-3 and Table 4-4. Other engineered antenna mast and support structure grounding systems may include metallic antenna support structures that are directly and effectively bonded to effectively grounded structural building steel (metal frame/framework).

Where a lightning protection system is installed on the building, roof-mounted antenna masts and support structures **shall** be bonded to the lightning protection system (IEC 62305-3:2010, section E.5.2.4.2.6, and NFPA 780-2017, section 4.17). The conductor **shall** be of the same size as the Main Roof Perimeter Lightning Protection Ring (FAA STD-019e, section 4.2.3.5.5, and NFPA 780-2017, section 4.17). Conductor bonding **shall** be made using exothermic welding, listed irreversible high-compression fittings or other fittings listed for use in lightning protection systems. See “Bonding to the External Grounding and Bonding System” on page 4-57. No additional grounding **shall** be required of roof-mounted antenna masts and support structures where bonded to a lightning protection system. See Figure 4-95.

Where a lightning protection system is not available, roof-mounted antenna masts and metal support structure **shall** be grounded by directly bonding to the building's grounding electrode system or to a supplemental grounding electrode system (FAA STD-019e, section 4.2.3.5.5). Bonding to the grounding electrode system should use effectively grounded structural building steel (metal frame/framework) where available. Where effectively grounded structural building steel (metal frame/framework) is not available, bonding to the grounding electrode system **shall** use at least two down conductors sized according to Table 4-5 or lightning protection system conductors sized according to Table 4-3 and Table 4-4, where practicable (ATIS-0600334.2013, section 8.2). The down-conductors **shall** be physically separated as much as practicable. See Figure 4-96.

Where effectively grounded structural building steel (metal frame/framework) is not available and the use of two down-conductors is not practicable, the use of a single down-conductor may be used only if approved by an engineer. In this case a larger conductor or lightning protection system conductor should be used (see “Down-Conductors” on page 4-40). Available water piping systems may also be used as a grounding down-conductor, but should only be used under the advice of an engineer.

Bonding to the structural building steel (metal frame/framework) **shall** be made using exothermic welding, listed irreversible high-compression fittings or other fittings listed for use in lightning protection systems. See NFPA 780-2017, section 4.19, and associated subsections for additional information regarding the use of structural building steel (metal frame/framework) as a main grounding conductor.

Figure 4-97 shows examples of acceptable building steel (metal frame/framework) bonding connections.

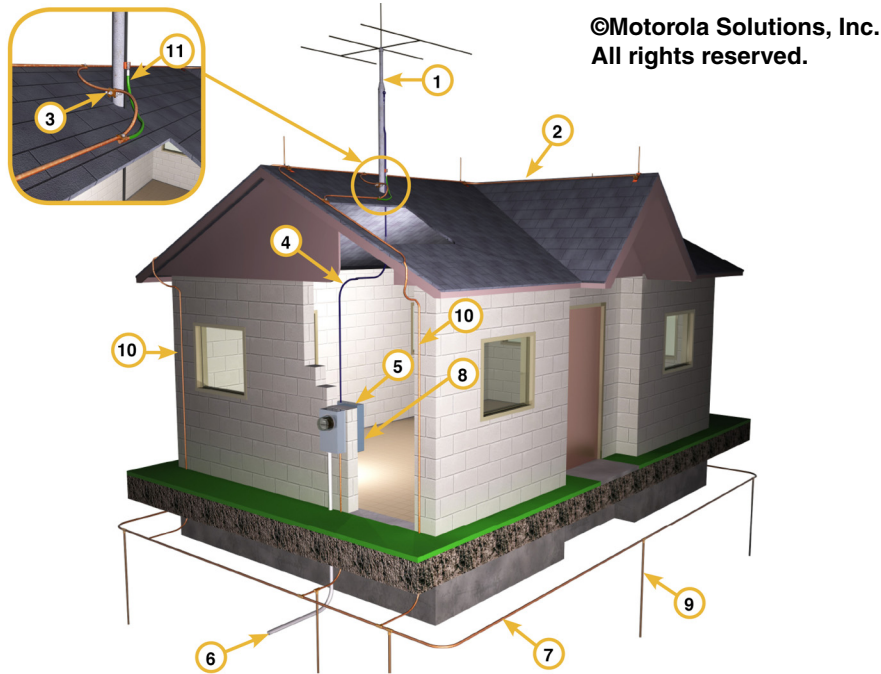

©Motorola Solutions, Inc.
All rights reserved.

1	METALLIC MAST
2	LIGHTNING PROTECTION CONDUCTOR RUN ON RIDGE
3	BOND METALLIC MAST TO LIGHTNING PROTECTION SYSTEM
4	ANTENNA CABLE
5	MAIN GROUNDING BUS BAR, METALLIC SHIELD ON THE ANTENNA CABLE IS CONNECTED TO THE BUS BAR
6	ELECTRICAL CABLE
7	GROUND RING CONDUCTOR
8	MAIN ELECTRICAL POWER DISTRIBUTION BOX WITH SPD
9	GROUND ROD
10	LIGHTNING PROTECTION DOWN CONDUCTOR
11	COAX GROUND KIT BONDED TO LIGHTNING PROTECTION CONDUCTOR

Figure 4-95 Antenna Bonding to Lightning Protection System

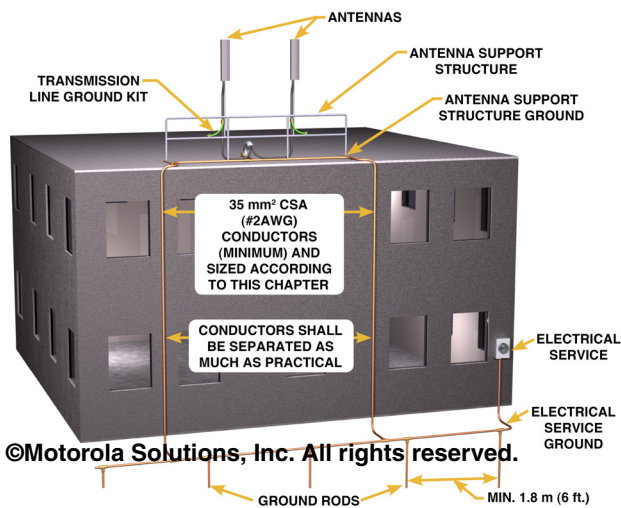

©Motorola Solutions, Inc. All rights reserved.

Figure 4-96 Roof Mounted Antenna Mast Grounding with Supplemental Grounding Electrode System

©Motorola Solutions, Inc. All rights reserved.

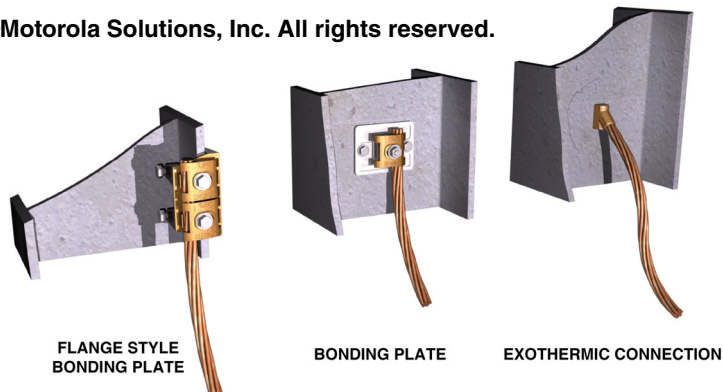

Figure 4-97 Acceptable Structural Building Steel Bonding Connections

Where used, grounding down-conductors **shall** meet the following requirements:

- Down-conductors **shall** be routed to the grounding electrode system from opposite sides of the roof where practicable (ATIS-0600334.2013, section 8.2).
- Down-conductors **shall** be physically separated from one another as much as is practicable (ATIS-0600334.2013, section 8.2).
- Grounding down-conductors **shall** be sized according to length as shown in Table 4-5, or a lightning protection system conductor may be used (see “Down-Conductors” on page 4-40 for lightning protection system conductor sizing).
- Grounding down-conductors **shall** be permitted to be run either outside or inside the building or structure (NFPA 70-2017, Article 810.21(G)). Outside the building is the preferred method and should be used where practicable.
- Where practicable, grounding down-conductors **shall** maintain a separation of at least 1.8 m (6 ft) from communications wires, cables and equipment (see NFPA 70-2017, Article 800.53, for more information).
- Grounding down-conductors **shall not** be required to be insulated (NFPA 70-2017, Article 810.21(B)). Insulated conductors are recommended where the grounding conductor may come into incidental contact with other metallic objects. Incidental contact with other metallic object may be a point for RF interference. See Chapter 8, “Minimizing Site Interference”.
- Grounding down-conductor bending and routing **shall** be made according to “Bending and Routing Grounding (Earthing), Bonding and Down-Conductors” on page 4-38.
- Grounding down-conductors **shall** be protected and secured according to “Protecting and Securing Grounding, Bonding and Down-Conductors” on page 4-39.
- If the building grounding electrode system resistance cannot be verified or cannot provide a low-resistance to earth (see “Grounding (Earthing) Electrode System Testing/Verification and Bonding Continuity Testing/Verification” on page D-1), a supplemental grounding electrode system should be installed to ensure the resistance requirement of the site is met. The supplemental grounding electrode system **shall** be bonded to the existing grounding electrode system according to “Common Grounding” on page 4-6. See “Supplemental Grounding (Earthing)” on page 4-78 for examples of a supplemental grounding electrode system.



NOTE

Depending on the locations available for grounding down-conductors and the entry point of the RF transmission lines into the building, it may be necessary to install a supplemental grounding electrode system. If installed, the supplemental grounding electrode system **shall** bond to the building ground.



NOTE

Consult the building engineer or manager for information about any existing building grounding electrode systems. Notify the building engineer before attempting to weld or drill on the building rooftop.

**IMPORTANT**

Where installed, supplemental grounding electrode systems shall be effectively bonded to the building grounding electrode system. See “Common Grounding” on page 4-6.

4.11.1 Side Mounted Antenna Grounding

Typically, a side mounted antenna may be grounded with a single grounding conductor. However, two down-conductors and an External Ground Bus bar (EGB) should be used where practicable; this is especially important at buildings that are normally occupied, such as dispatch centers (see Figure 4-98). Where two grounding down-conductors are not installed, it is recommended to either use a copper strap (Figure 4-99) or a larger-sized grounding down-conductor (such as #4/0 AWG). Grounding down-conductors **shall** be sized according to Table 4-5, or lightning protection system conductors may be used according to Table 4-3 and Table 4-4. See TIA-607-C, section C.2.6, for more information.

**NOTE**

An External Ground Bus bar (EGB) should be used for side mounted antenna applications. An EGB simplifies grounding of the antenna support structure and RF cables (see Figure 4-99).

Where multiple side-mounted antennas are installed together, a single horizontal grounding conductor should bond all antenna mounts together. The horizontal grounding conductor should bond to each side of an External Ground Bus bar (EGB) as shown in Figure 4-100.

A grounding down-conductor **shall** bond the horizontal grounding conductor to the grounding electrode system from each side of the antennas (see NFPA 780-2017, section 4.9.10, and associated subsections for more information). Where a horizontal grounding conductor is used, grounding down-conductors **shall** be installed at least every 30 m (100 ft) (NFPA 780-2017, section 4.9.10.2); 15 m (50 ft) intervals are recommended for improved protection. Grounding down-conductors **shall** be sized according to Table 4-5, or lightning protection system conductors sized according to Table 4-3 and Table 4-4.

**NOTE**

Ground rods (or other electrodes) should be installed at 3 m to 4.5 m (10 to 15 ft) intervals between down conductors.

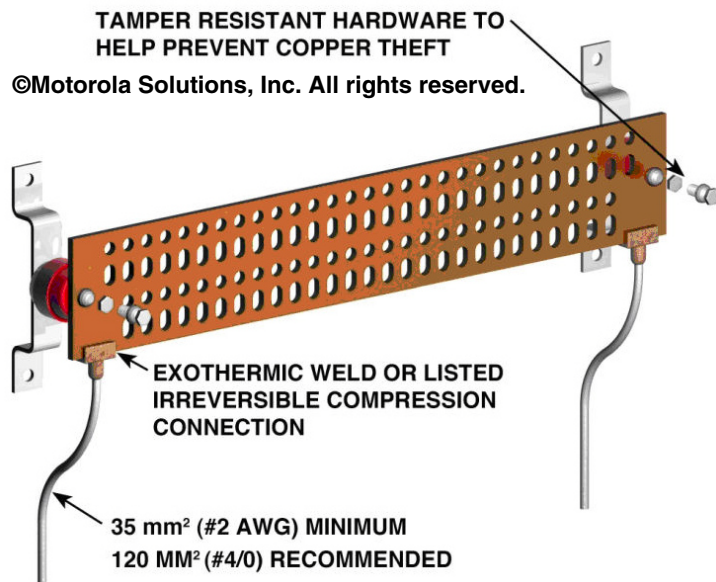

Figure 4-98 Minimum Recommended Bus Bar Installation for Side Mounted Antenna

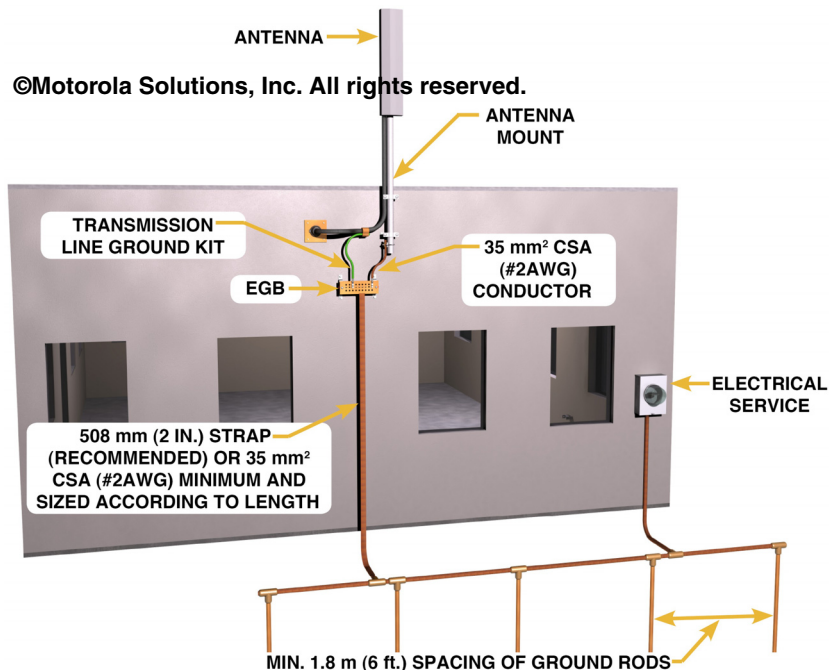

Figure 4-99 Side-Mounted Antenna Grounding Using Copper Strap Down Conductor

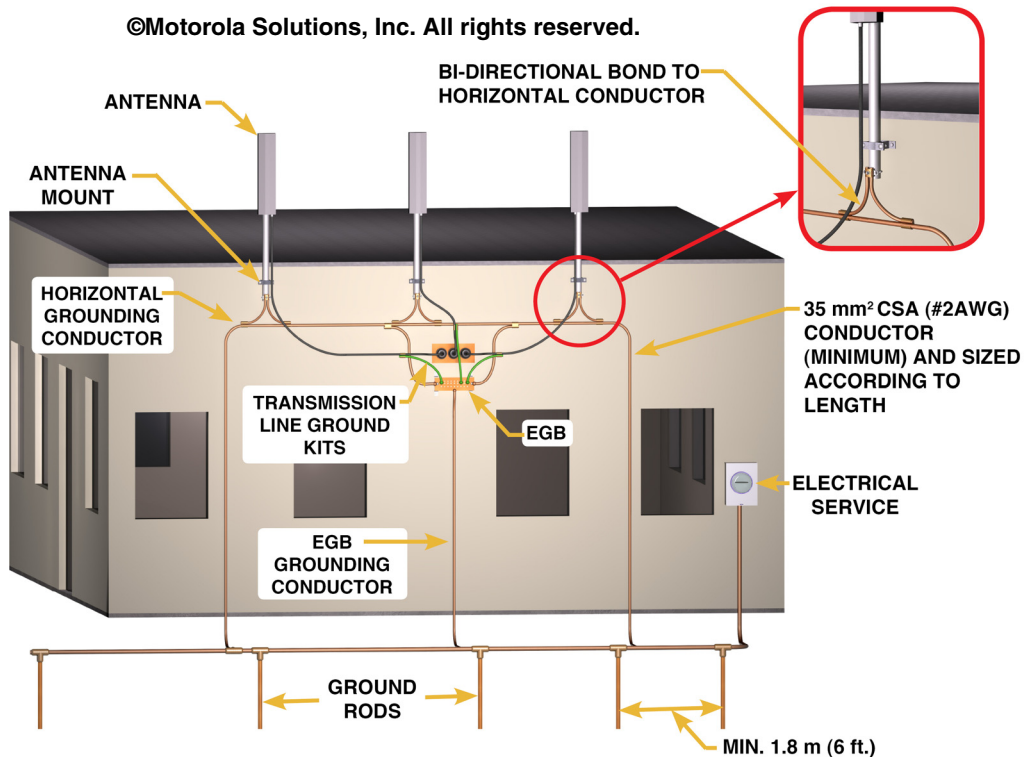

Figure 4-100 Grounding of Multiple Side-Mounted Antennas

4.12 Grounding (Earthing) Rooftop Mounted Tower Structures

Rooftop mounted towers may increase the lightning risk index for the buildings they are installed upon. Due to their increased height and lightning risk probability, all exposed buildings with rooftop towers **shall** be equipped with a lightning protection system, as outlined in NFPA 780-2017 or IEC 62305-3:2010 (ATIS-0600313.2013, section 10.3.3, and ATIS-0600334.2013, section 7.9). See “Lightning Activity and Exposure” on page 4-3 for information regarding lightning exposure to buildings and towers. See TIA-607-C, section C.2.6, for more information.



NOTE

For the purpose of this section, a tower **shall** be considered any metallic structure used to support communications antennas and/or dishes that exceeds 6.096 m (20 ft.) in height above the building roofline. A Lightning Protection System (LPS) engineering firm may determine an alternate minimum height for tower structures that requires an LPS, based on a lightning risk assessment. In all cases, the requirements of the Authority Having Jurisdiction (AHJ) **shall** be followed. If the LPS engineering firm determines that an LPS is not required, the requirements of “Grounding Roof-Mounted Antenna Masts and Metal Support Structures” on page 4-114 **shall** be followed.



IMPORTANT

Consult the building engineer or manager for information about any existing building grounding electrode systems. Inform the building engineer before attempting to weld or drill on the building rooftop.

An engineering firm specializing in the design and installation of lightning protection systems should be consulted for proper design and installation of the building lightning protection system. A qualified contractor specializing in the installation of lightning protection systems should be used. The lightning protection system **shall** be constructed of only listed components. The lightning protection system **shall** meet the requirements of one of the following codes/standards (current edition): BS/EN 62305-3, CAN/CSA-B72-M87, IEC 62305-3, NFPA 780 or other code/standard in effect and recognized by the Authority Having Jurisdiction (AHJ).



IMPORTANT

Early Streamer Emission devices and Lightning Elimination devices are not internationally recognized as approved lightning protection components and shall not be used for lightning protection systems.

4.12.1 Lightning Protection System

At a minimum, the lightning protection system **shall** contain the following (see Figure 4-101):

- A grounding conductor installed around the roof perimeter to form the *main roof perimeter lightning protection ring*. The main roof perimeter lightning protection ring **shall** be sized according to building height as required by NFPA 780-2017, Table 4.1.1.1.1 and 4.1.1.1.2. See “Down-Conductors” on page 4-40, Table 4-3 and Table 4-4 for more information.
- Strike termination devices, also known as air terminals, installed along the length of the main roof perimeter lightning protection ring, typically every 6.1 m (20 ft) or as otherwise required by the Authority Having Jurisdiction.
- At least two down-conductors from the main roof perimeter lightning protection ring to the grounding electrode system. The down conductors **shall** be physically separated from one another as much as practicable. The down conductors **shall** be sized according to building height as required by NFPA 780-2017, Table 4.1.1.1.1 and 4.1.1.1.2. See Table 4-3 and Table 4-4 for lightning protection system conductor sizing.

**NOTE**

Electrically continuous and effectively grounded structural building steel (metal frame/framework) can be used as a grounding down-conductor (as permitted by BS/EN 62305-3, CAN/CSA-B72-M87, IEC 62305-3 or NFPA 780-2017). The conductor used to bond the main roof perimeter lightning protection ring to the structural building steel (metal frame/framework) **shall** be sized as required by NFPA 780-2017 (or other code/standard recognized by the Authority Having Jurisdiction) according to the building height (see Table 4-3 and Table 4-4). See Figure 4-97 for an example of acceptable structural building steel (metal frame/framework) bonding connections.

- Structures exceeding 76 m (250 ft) in perimeter **shall** have a down conductor for every 30.5 m (100 ft) of perimeter or fraction thereof (NFPA 780-2017, section 4.9.10.1).
- Other metallic objects on the roof **shall** be bonded to the roof perimeter lightning protection system ring as required by one of the following standards: BS/EN 62305-3, CAN/CSA-B72-M87, IEC 62305-3, NFPA 780-2017 or other code/standard recognized by the Authority Having Jurisdiction.
- All grounding electrode systems at the building **shall** be bonded together to form a single grounding electrode system. See “Common Grounding” on page 4-6.

4.12.2 Rooftop Tower Bonding to the Lightning Protection System

The rooftop mounted tower **shall** be effectively grounded by bonding to the lightning protection system. The rooftop mounted tower **shall** bond to the lightning protection system as follows (see Figure 4-101):

- The rooftop mounted tower support legs **shall** be interconnected with a conductor at or near the tower attachment to the roof structure, thereby forming a roof tower ground ring. The roof tower ground ring conductor **shall** be 35 mm² csa (#2 AWG) or larger.
 - A guyed tower base plate can be used in place of the roof tower ground ring.
 - A monopole tower does not require a roof tower ground ring because of its single leg construction. However, the monopole must be bonded to the main roof perimeter lightning ring as described in this section.
- The roof tower ground ring grounding conductors (between the roof tower ring and tower) **shall** be exothermically bonded to the tower unless specifically directed otherwise by the tower manufacturer. In such cases, listed mechanical clamping devices may be used. See “Above-Grade Mechanical Lugs and Connection Devices” on page 4-58.
- The rooftop mounted tower ground ring, guyed tower base plate or monopole **shall** bond to the main roof perimeter lightning protection ring with a minimum of two opposing conductors at or within 610 mm (24 in.) of a grounding down-conductor or other main grounding conductor (such as effectively grounded structural building steel or metal frame/framework) as defined by BS/EN 62305-3, CAN/CSA-B72-M87, IEC 62305-3 or NFPA 780-2017.
 - The conductors **shall** meet the installation requirements of “Grounding (Earthing), Bonding and Down-Conductors” on page 4-37.
 - The conductors **shall** be 35 mm² csa (#2 AWG) or larger. Listed lightning protection system conductors are recommended. See “Down-Conductor Sizing” on page 4-40.
 - Conductor bonding **shall** be made using exothermic welding, listed irreversible high-compression fittings or other fittings listed for use in lightning protection systems.

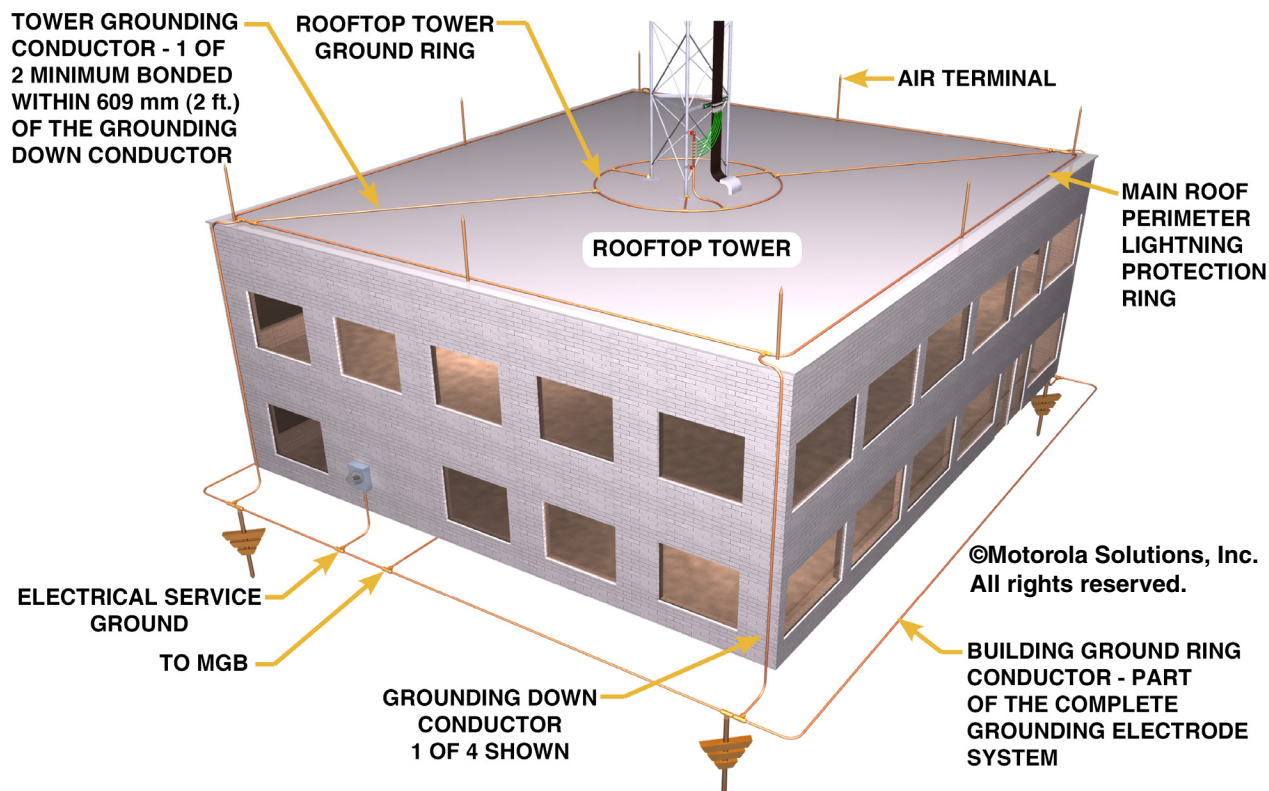

Figure 4-101 Typical Rooftop Tower Grounding

4.12.2.1 Additional Bonding Requirements for Guyed Towers

- Tower guy anchors that are attached directly to the building **shall** be bonded to the main roof perimeter lightning protection ring (ATIS-0600313.2013, section 10.3.3.). Guy anchors that are connected to and made electrically continuous to effectively bonded structural building steel (metal frame/framework) may not require any additional connections to the lightning protection system.
 - The conductors **shall** meet the installation requirements of “Grounding (Earthing), Bonding and Down-Conductors” on page 4-37.
 - The conductors **shall** be 35 mm² csa (#2 AWG) or larger.
 - Conductor bonding **shall** be made using exothermic welding, listed irreversible high-compression fittings or other fittings listed for use in lightning protection systems. See “Bonding to the External Grounding and Bonding System” on page 4-57.
- Guy wires **shall** be grounded using similar techniques described in “Steel Guy Anchor Point Grounding” on page 4-86 and Figure 4-68.
- The guy wire grounding conductor **shall** bond to the main roof perimeter lightning protection ring or to the grounded guy anchor. See Figure 4-102.
 - The conductors **shall** meet the installation requirements of “Grounding (Earthing), Bonding and Down-Conductors” on page 4-37.
 - The conductors **shall** be 35 mm² csa (#2 AWG) or larger.
 - Conductor bonding **shall** be made using exothermic welding, listed irreversible high-compression fittings or other fittings listed for use in lightning protection systems. See “Bonding to the External Grounding and Bonding System” on page 4-57.

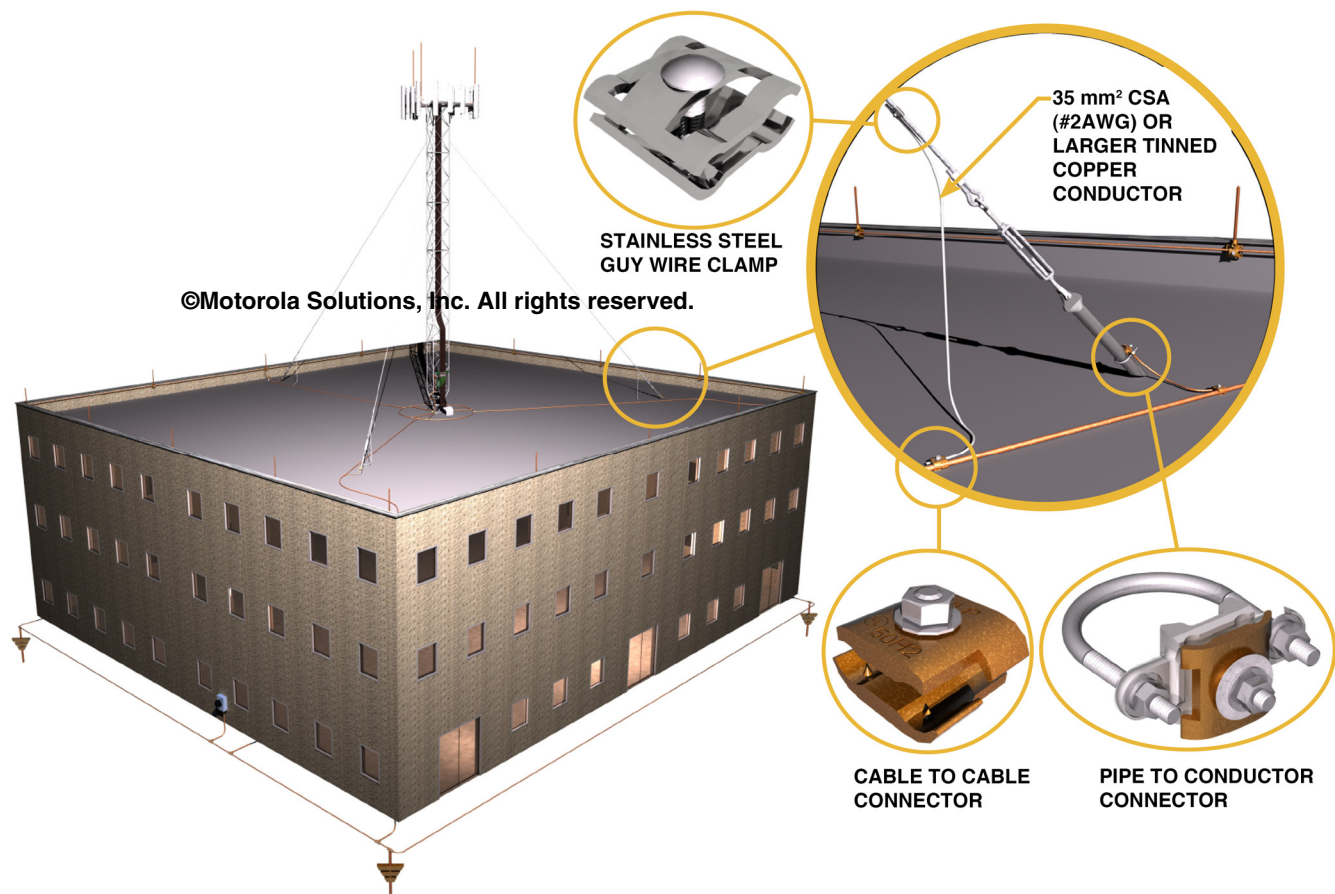

Figure 4-102 Typical Rooftop Tower Guy Anchor Point Grounding

4.13 Special Grounding (Earthing) and Bonding Applications

Some communications site locations and/or applications require special consideration for effective grounding and bonding. The following sections describe techniques for grounding and bonding some common communications applications. Consultation with Motorola Solutions Engineering or other engineering firm may be required in some situations.

4.13.1 Dispatch Centers Co-Located With Communications Towers

Dispatch centers co-located with communications towers require special protection considerations due to the critical nature of their operation and the inherent lightning risk to personnel. For optimum protection of a dispatch center, the following **shall** be considered:

- Site design recommendations given in “Design Considerations to Help Reduce Effects of Lightning” on page 2-16 and Figure 4-103.
 - Cable entry port within 610 mm (2 ft) of the floor (NWSM 30-4106, Figure 2-2).
 - 9.1 m (30 ft) minimum distance between tower and building (IEEE 1692-2011, section 7; and TIA-607-C, Figure 25).
- Internal bonding and grounding as defined in “Bonding and Grounding (Earthing) for Dispatch Centers and Network Operator Positions” on page 5-133.
- Surge Protective Devices (SPD) as defined in “Surge Protection Considerations for Dispatch Centers and Operator Positions” on page 7-50.

- Electrostatic discharge (ESD) precautions as defined in “Protecting Against Electrostatic Discharge in Equipment Rooms and Dispatch Centers” on page C-1.
- External grounding and bonding as follows:
 - Grounding electrode system resistance design goal of 5 ohms or less (see IEEE 1692-2011, section 8.1). See “Type “B2” Sites: Extra Duty” on page 4-78.
 - Installation of all minimum required grounding electrode system components as described in “Dedicated Communications Building Grounding (Earthing)” on page 4-92.
 - Bonding of all metallic objects as described in “Metallic Objects Requiring Bonding” on page 4-101.
 - Installation of radial grounding conductors as described in “Radial Grounding Conductors” on page 4-28. Radial grounding conductors should be installed regardless if the grounding electrode system resistance is 5 ohms or less without the radial grounding conductors. A minimum of three radial grounding conductors **shall** be installed, if practicable (TIA-607-C, section B.8).

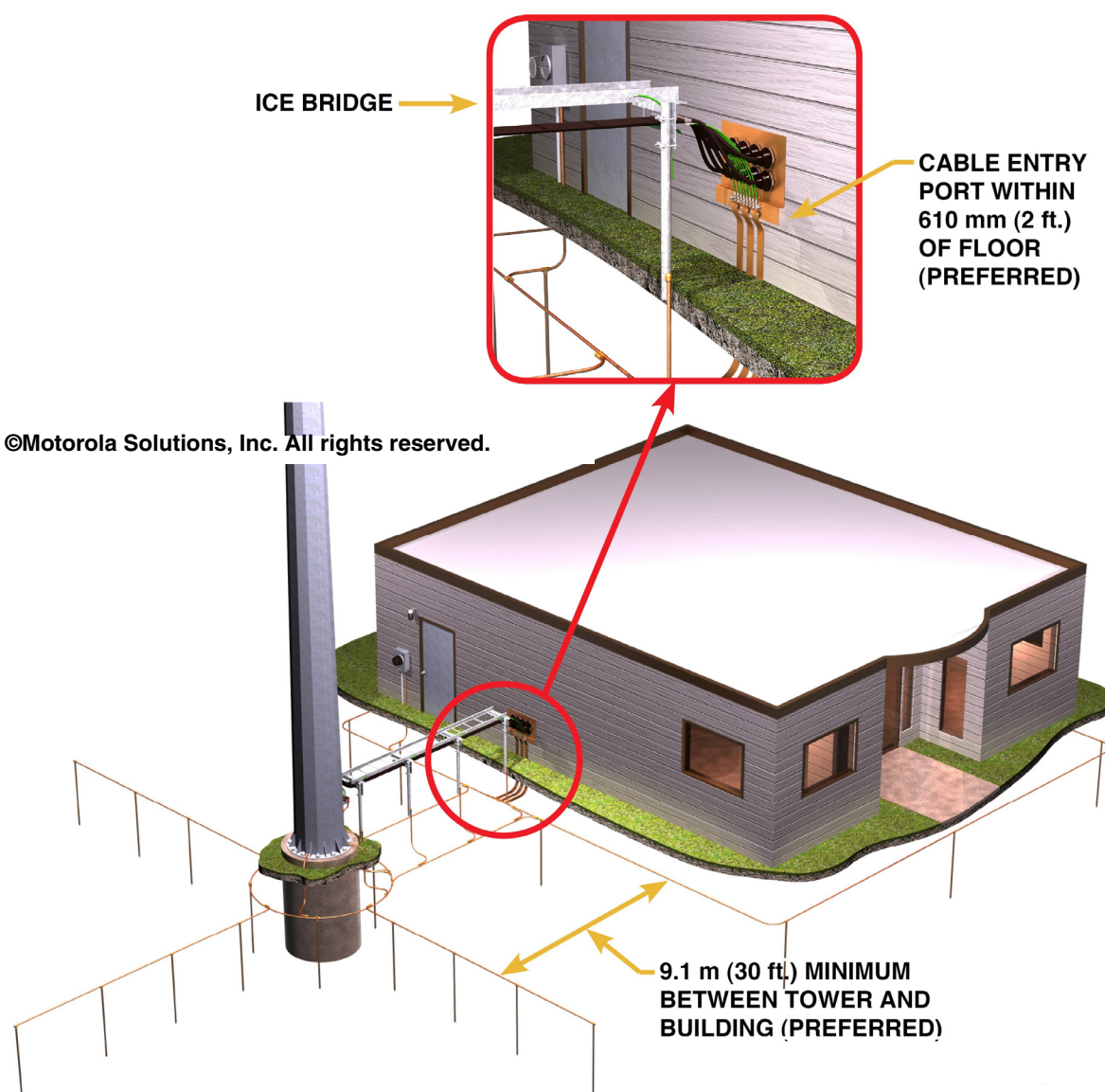

Figure 4-103 Grounding Electrode System for Dispatch Center Co-Located with a Tower

4.13.2 Two or More Separate, Electrically Interconnected Buildings in the Same Area

Where two or more structures or facilities are located in the same general area (less than 61 m (200 ft) apart) and are electrically interconnected with the continuous metallic shield of a cable (for example, signal, control, RF, monitor circuits or other communications cables), special grounding techniques must be considered. Either a common grounding electrode system **shall** be provided, or the separate grounding electrode systems **shall** be interconnected with two buried grounding conductors.

Where installed, the interconnecting grounding conductors **shall** be 50 mm² csa (#1/0 AWG) or larger, bare, copper. The buried grounding conductors **shall** be installed in separate trenches that are separated as much as practicable (at least 6 ft). The conductors **shall** be buried to a minimum depth of 457 mm (18 in.) below grade, where practicable. Access to the grounding conductor bonding points should include ground test wells.

For additional information, see Figure 4-104; “Ground Inspection Wells” on page 4-35; and MIL-HDBK-419A Volume II, section 1.2.3.



IMPORTANT

For optimum protection from transient voltage events and ground potential rise, optical fiber links (or other isolation protection) are recommended for all inter-building links. Non-shielded fiber should be used. See IEEE 1692-2011 for more information.

Separate structures spaced closer than 6 meters (20 ft) should have a common grounding electrode system installed that encircles both facilities (MIL-HDBK-419A Volume II, section 1.2.3). See Figure 4-105.

Structures or facilities having no interconnection cables and separated by a distance greater than 61 m (200 ft) generally do not require their grounding electrode systems to be interconnected (MIL-HDBK-419A Volume II, section 1.2.3).

Buildings sharing a common tower require bonding of their respective ground rings to the common tower ground ring. See Figure 4-106.

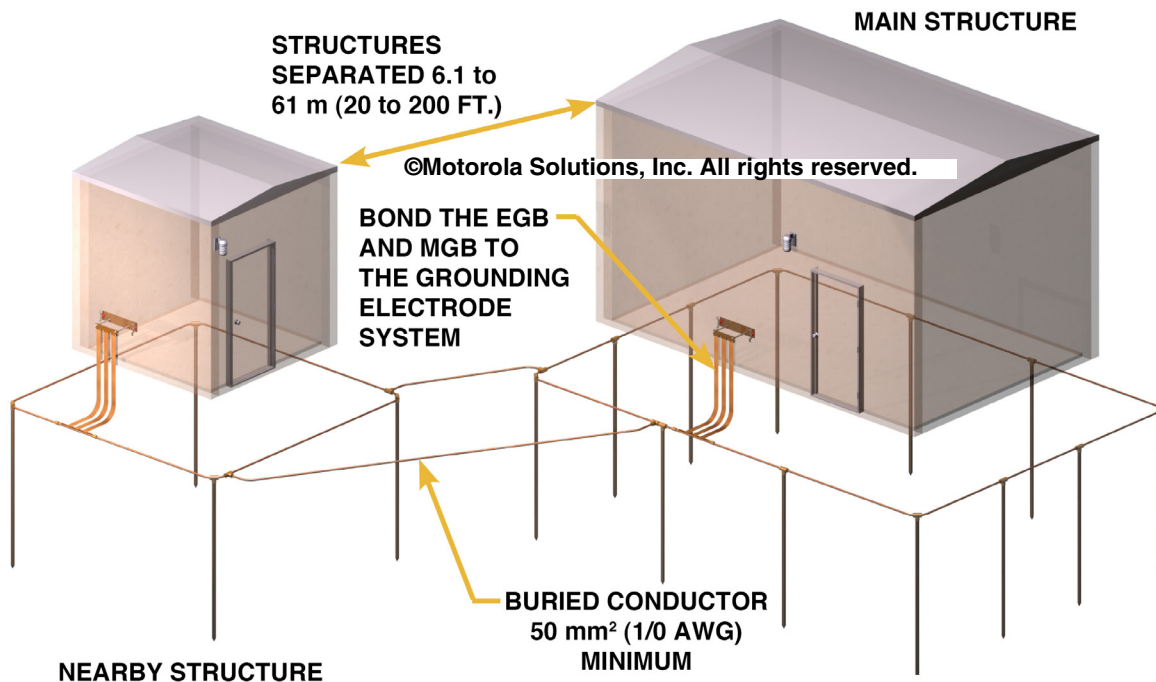

Figure 4-104 Two Electrically Interconnected Buildings Located in the Same Area

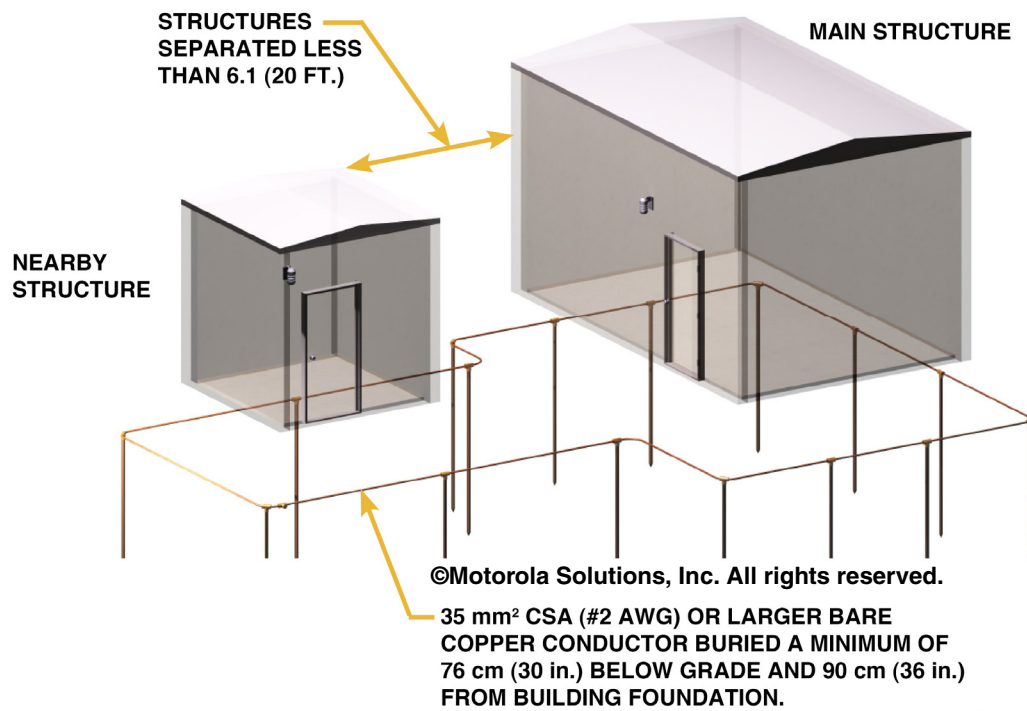

Figure 4-105 Separate Structures with Common Ground Ring

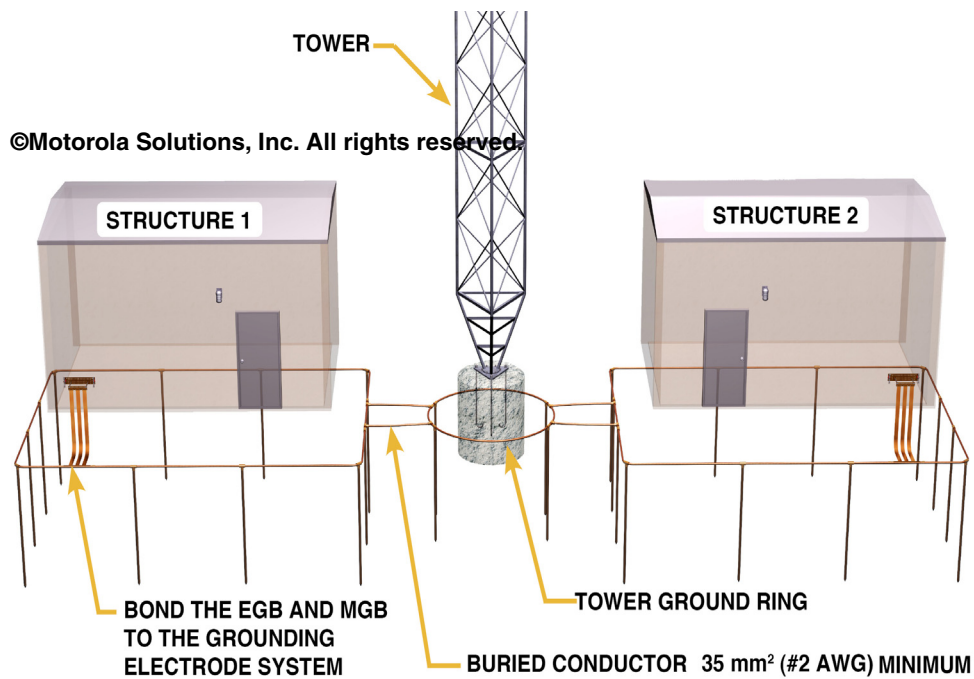

Figure 4-106 Bonding Two Structures Adjacent to Tower

4.13.3 Grounding and Bonding for Access Points, Wireless Routers, Point-to-Point and Similar Devices

Access points, wireless routers, point-to-point and similar devices are typically installed in a variety of locations, such as communications towers, building rooftops or utility/light poles. Typical locations are addressed in this section.

4.13.3.1 Tower-Mounted Devices

Grounding and bonding requirements for tower-mounted devices (access points, wireless routers, point-to-point, external surge protective devices (SPD) associated with the electronic equipment and similar devices) are as follows.

- Tower mounted devices **shall** be bonded to the tower using a 16 mm² csa (#6 AWG) or larger, tinned and/or jacketed, copper conductor. Conductors longer than 3.96 m (13 ft) **shall** be 35 mm² csa (#2 AWG) or larger.
- Devices that contain internal surge protective devices **shall** bond to the tower using a 35 mm² csa (#2 AWG) or larger conductor.
- Grounding conductors **shall** also be sized according to length as shown in Table 4-5.
- Connection to the device **shall** be made to an adequately-sized dedicated grounding point according to the device manufacturer requirements.
- Connection to the tower **shall** be made using tower manufacturer-approved methods (typically a type of mechanical clamp or to an existing tower ground bus bar).
- The grounding conductor **shall** meet the specifications and installation requirements of “Grounding (Earthing), Bonding and Down-Conductors” on page 4-37.
- The tower **shall** be grounded as described in “Tower Grounding (Earthing)” on page 4-79 or “Grounding (Earthing) Rooftop Mounted Tower Structures” on page 4-119.
- RF transmission lines and other device input/output cables **shall** be grounded and bonded as described in “Grounding and Bonding of RF Transmission Lines and Other Communications Cables” on page 4-97.



IMPORTANT

For increased protection of the device, the device should not be installed on the extreme top of the tower unless protected by a lightning protection system strike termination device (or equivalent).



NOTE

External surge protective devices (SPD) associated with the electronic equipment **shall** be grounded as described previously for tower-mounted devices.

4.13.3.2 Internal Building-Mounted Devices

Building-mounted access points, wireless routers, point-to-point and similar devices installed inside the building **shall** be bonded and grounded as required for electronic equipment in Chapter 5, “Internal Bonding and Grounding (Earthing)”.

4.13.3.3 Building Side-Mounted Devices

The grounding and bonding requirements for access points, cameras, wireless routers, point-to-point, external Surge Protective Devices (SPD) associated with the electronic equipment, and similar devices mounted on the side of a building are as follows:

- Devices mounted to the side of a building **shall** be bonded directly to the building's common grounding electrode system using a 16 mm² csa (#6 AWG) or larger, copper conductor. Conductors longer than 3.96 m (13 ft) **shall** be 35 mm² csa (#2 AWG) or larger.
- Devices that contain internal surge protective devices **shall** bond to the grounding electrode system using a 35 mm² csa (#2 AWG) or larger conductor.

- Grounding conductors **shall** also be sized according to length as shown in Table 4-5, or lightning protection system conductors may be used. The lightning protection system conductors may be copper or aluminum, as appropriate for the site specific conditions (see “Down-Conductors” on page 4-40).
- Connection to the device **shall** be made to an adequately-sized dedicated grounding point according to the device manufacturer requirements.
- The grounding conductor **shall** meet the specifications and installation requirements of “Grounding (Earthing), Bonding and Down-Conductors” on page 4-37.
- Metallic mounting masts used for supporting access points, wireless routers, point-to-point and similar devices **shall** be grounded in the same manner as described in “Side Mounted Antenna Grounding” on page 4-117.

**NOTE**

External SPD associated with the electronic equipment **shall** be grounded in the same manner as described previously for building side-mounted devices.

4.13.3.4 Roof-Mounted Devices

The grounding and bonding requirements for roof mounted access points, cameras, wireless routers, point-to-point, external Surge Protective Devices (SPD) associated with the electronic and similar devices are as follows:

- Devices mounted on the roof of a building **shall** be bonded directly to the building's common grounding electrode system using a 16 mm² csa (#6 AWG) or larger, copper conductor. Conductors longer than 3.96 m (13 ft) **shall** be 35 mm² csa (#2 AWG) or larger.
- Devices that contain internal surge protective devices **shall** bond to the grounding electrode system using a 35 mm² csa (#2 AWG) or larger conductor.
- Grounding conductors **shall** also be sized according to length as shown in Table 4-5, or lightning protection system conductors may be used. The lightning protection system conductors may be copper or aluminum, as appropriate for the site specific conditions (see “Down-Conductors” on page 4-40).
- Connection to the device **shall** be made to an adequately-sized dedicated grounding point according to the device manufacturer requirements.
- The grounding conductor **shall** meet the specifications and installation requirements of “Grounding (Earthing), Bonding and Down-Conductors” on page 4-37.
- Metallic mounting masts used for supporting access points, wireless routers, point-to-point and similar devices **shall** be grounded in the same manner as described in “Grounding Roof-Mounted Antenna Masts and Metal Support Structures” on page 4-114.

An available bonding location to the building's common grounding electrode system may include the following:

- Effectively grounded structural building steel (metal frame/framework).
- An existing communications grounding system.
- An existing lightning protection system down-conductor.
- A grounding down-conductor sized according to “Down-Conductors” on page 4-40 (may include lightning protection system conductors). The lightning protection system conductors may be copper or aluminum, as appropriate for the site specific conditions (see “Down-Conductors” on page 4-40).
- Other connections to earth as designed by Motorola Solutions Engineering or other engineering firm.

**IMPORTANT**

For increased protection of the device, do not install the device at the extreme top of the metallic mounting mast unless protected by a lightning protection system strike termination device (or equivalent). See Figure 4-107.

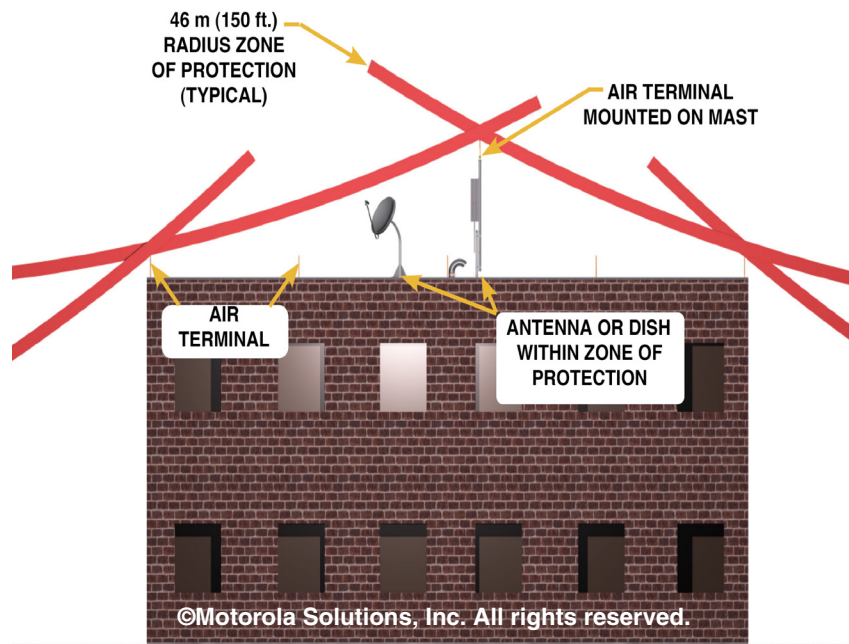

Figure 4-107 Device Installed Within Zone of Protection



NOTE

External SPD associated with the electronic equipment **shall** be grounded in the same manner as described previously for roof-mounted devices.

4.13.3.5 Utility/Light Pole Mounted

The follow sections describe grounding and bonding requirements for utility/light pole mounted access points, cameras, wireless routers, point-to-point, external Surge Protective Devices (SPD) associated with the electronic equipment and similar devices. Before work can begin on a utility pole, written approval **shall** be received from the utility and/or Authority Having Jurisdiction (AHJ).



WARNING

High voltage hazards may exist with utility pole installations. Only properly trained and qualified personnel **SHALL** perform communications equipment installations and maintenance on utility poles and **SHALL** follow applicable OSHA regulations (or equivalent). Qualification and training **SHALL** be determined by the utility and/or Authority Having Jurisdiction.



WARNING

Installations on utility poles **SHALL** meet all installation and clearance requirements of the *National Electrical Safety Code®* (or equivalent), the electric utility (or utility that owns the pole) or other Authority Having Jurisdiction.

4.13.3.5.1 Metallic Pole Mounted

Devices **shall** be installed at a utility-approved location with clearances as described in “Utility Pole Required Clearances” on page 9-68. The WARNINGS on page 4-128 **shall** be followed.

Devices mounted to metallic utility poles are grounded and bonded in the same general manner as described previously for tower-mounted devices (see Figure 4-108):

- Devices **shall** be bonded to the pole using a 16 mm² csa (#6 AWG) or larger, tinned and/or jacketed, copper conductor. Conductors longer than 3.96 m (13 ft) **shall** be 35 mm² csa (#2 AWG) or larger.
- Devices that contain internal surge protective devices **shall** bond to the pole using a 35 mm² csa (#2 AWG) or larger conductor.
- Grounding conductors **shall** also be sized according to length as shown in Table 4-5.
- Connection to the device **shall** be made to an adequately-sized dedicated grounding point according to the device manufacturer requirements.
- Connection to the pole **shall** be made using appropriate mechanical clamps. See “Above-Grade Mechanical Lugs and Connection Devices” on page 4-58.
- The grounding conductor **shall** meet the specifications and installation requirements of “Grounding (Earthing), Bonding and Down-Conductors” on page 4-37.
- The metallic utility pole **shall** be effectively grounded or made to be effectively grounded. If the utility pole must be made effectively grounded, it **shall** minimally be grounded using at least one ground rod (or other electrode appropriate for the soil conditions). See “Grounding System Component and Installation Requirements” on page 4-7.

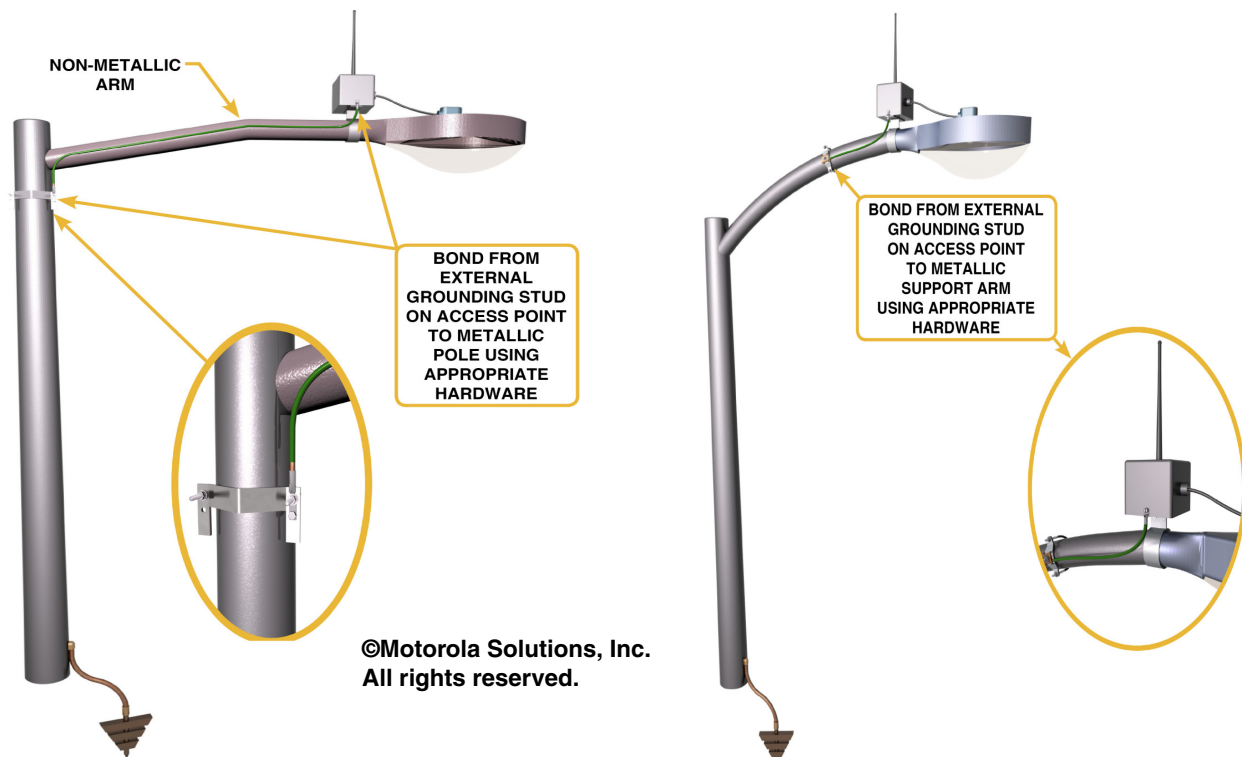

Figure 4-108 Grounding Access Point Mounted on Metal Pole



IMPORTANT

For lightning protection purposes, the metallic utility pole should have a locally installed grounding electrode, even if it is bonded with an equipment grounding conductor.

**NOTE**

External SPD associated with the electronic equipment **shall** be grounded in the same manner as described previously for metallic pole-mounted devices.

**NOTE**

If the access point, wireless router, point-to-point or similar device is mounted to a non-metallic arm on the metallic utility pole, the device **shall** be grounded as described previously by bonding to the metallic portion of the pole as shown in Figure 4-108.

4.13.3.5.2 Non-Metallic Pole Mounted

Devices **shall** be installed at a utility-approved location with clearances as described in “Utility Pole Required Clearances” on page 9-68. The **Warnings** on page 4-128 **shall** be followed.

Non-metallic utility poles used for supporting access points, wireless routers, point-to-point and similar devices are grounded and bonded in a similar manner as described in “Wooden Structures (Poles)” on page 4-91. The devices **shall** be grounded and bonded as follows:

- The non-metallic utility pole **shall** have a vertical grounding conductor installed along the vertical length of the pole (or at least to the height of the device). See “Wooden Structures (Poles)” on page 4-91.
- The vertical grounding conductor **shall** be constructed of 35 mm² csa (#2 AWG) or larger, solid, bare, copper (ATIS-0600334.2013, section 6.5).
- Grounding conductors **shall** also be sized according to length as shown in Table 4-5.
- The vertical grounding conductor **shall** terminate into the earth at a grounding electrode system consisting of a least one ground rod (or other electrode appropriate for the soil conditions). Connection to the grounding electrode system **shall** be made according to “Below-Grade Connections” on page 4-64.
- Devices **shall** be bonded to the pole’s vertical grounding conductor using a 16 mm² csa (#6 AWG) or larger, copper bonding conductor. Conductors longer than 3.96 m (13 ft) **shall** be 35 mm² csa (#2 AWG) or larger.
- Devices that contain internal surge protective devices **shall** bond to the pole’s vertical grounding conductor using a 35 mm² csa (#2 AWG) or larger bonding conductor.
- Connection to the device **shall** be made to an adequately-sized dedicated grounding point according to the device manufacturer requirements.
- Connection to the pole’s vertical grounding conductor **shall** be made using appropriate methods (such as exothermic welding or irreversible high-compression fittings). See “Bonding to the External Grounding and Bonding System” on page 4-57.
- The grounding conductor **shall** meet the specifications and installation requirements of “Grounding (Earthing), Bonding and Down-Conductors” on page 4-37. Where the vertical grounding conductor is exposed to damage, it **shall** be protected for at least 2.44 m (8 ft) above ground or other surface (*National Electrical Safety Code*®).

**NOTE**

Non-metallic poles with a transformer typically contain a locally installed ground rod, as per the *National Electrical Safety Code*® (*NESCA*®). If installed, this ground rod can be used for grounding the communications device. The vertical grounding conductor may bond directly to the ground rod or to the transformer grounding electrode conductor (as close as practicable to the rod). Bonding to the ground rod or grounding electrode conductor **shall** use exothermic welding or listed irreversible high-compression fittings. See “Bonding to the External Grounding and Bonding System” on page 4-57.

**NOTE**

External SPD associated with the electronic equipment **shall** be grounded in the same manner as described previously for non-metallic pole mounted devices.

**IMPORTANT**

To prevent a difference of potential, any grounding electrode installed for grounding the communications device shall be bonded to any other electrode at the pole (may be a pole butt plate, wire wrap and/or ground rod). See the *NESC®* for more details on available pole grounding electrodes.



Figure 4-109 Grounding Access Point Mounted on Non-Metallic Pole

**NOTE**

The *National Electrical Safety Code®* is also known as the American National Standards Institute C2 (ANSI C2).

4.13.4 Metal Shipping Containers used as Communications Buildings

Grounding electrode systems for metal shipping containers used as communications buildings **shall** conform to the requirements specified in this chapter for a dedicated communications building (see “Dedicated Communications Building Grounding (Earthing)” on page 4-92). All equipment inside the shipping container **shall** conform to the bonding and grounding requirements of Chapter 5, “Internal Bonding and Grounding (Earthing)”.

In addition to the requirements listed previously, the outside of the shipping container **shall** be bonded to the grounding electrode system at all four corners (minimally) using 35 mm² csa (#2 AWG) or larger, copper conductors. Tinned-copper conductors are recommended. Requirements for bonding the metal shipping container to the grounding electrode system are as follows (see Figure 4-110):

- Each corner of the metal container **shall** bond directly to the grounding electrode system.

- Conductors **shall** meet the requirements of “Grounding (Earthing), Bonding and Down-Conductors” on page 4-37.
- Conductor bonding to the metal shipping container **shall** be exothermically welded where practicable. See “Exothermic Welding” on page 4-64. Where exothermic welding is not practicable, other suitable mechanical connections may be used.
- Conductor bonding to the grounding electrode system **shall** be made using exothermic welding or listed irreversible high-compression fittings. See “Bonding to the External Grounding and Bonding System” on page 4-57.



Figure 4-110 Grounding of Metal Shipping Containers

4.13.5 Grounding (Earthing) Electrode Systems Covered by Concrete or Asphalt

When installing a grounding electrode system, every attempt should be made to avoid covering the surface above the grounding electrode system with concrete or asphalt. Areas covered with concrete or asphalt will dry out over time, increasing the resistance to earth of the grounding electrode system (see MIL-HDBK-419A and TIA-607-C for additional information). Some alternatives to covering the area with concrete and asphalt are as follows:

- Cover the area with gravel.
- Landscape the area. If using a weed barrier, choose a water-permeable type.
- Use electrolytic ground rods where the area must be covered with concrete or asphalt. See “Electrolytic Ground Rods” on page 4-19.

4.13.6 Water Tank and Water Tower Installations

Antennas are commonly mounted to water tanks and water towers for convenience, economic and RF propagation reasons. Due to potential galvanic corrosion effects on water tank/tower piping systems, communications site grounding at a water tank/tower requires careful consideration and should involve an engineering firm and/or an engineer from the water utility. Any recommendations or requirements in this section **shall** be approved by the water utility before implementation.



IMPORTANT

There are many varieties of water tank construction materials. Accordingly, there are also many variations of water tank/tower installations. Consultation with Motorola Solutions Engineering or other engineering firm is recommended.

A grounding electrode system is typically not required to be installed at the water tank/tower because of the inherent construction of the water tank/tower. A grounding electrode system is required at the communications building/shelter and **shall** bond to the water tank/tower at a tank manufacturer-approved location. Such locations may include, but are not limited to, one of the following:

- Exothermic weld to the base of the tank/tower.
- Grounding stud attached to the tank/tower using capacitive discharge welding.
- Existing grounding electrode system connections to the tank/tower (other than cathodic protection systems).
- Other location approved by the tank/tower manufacturer and/or water utility.

A grounding electrode system installed at a water tank/tower communications site building/shelter **shall not** contribute to corrosion of the water tank/tower or piping system. Corrosion is typically prevented by using grounding electrode system components that are compatible with the water tank/tower and piping systems. Such components may include, but are not limited to, the following:

- Tinned-copper grounding conductors
- Galvanized steel ground rods
- Stainless steel ground rods
- Stainless steel electrolytic ground rods

**NOTE**

The water utility or corrosion specialist may require additional cathodic protection.

**IMPORTANT**

Any grounding electrode system that directly or indirectly bonds to the water tank/tower shall be approved by the water utility.

Antenna mounts and mounting structures on water tanks/towers **shall** be grounded. This can be accomplished by directly bonding the mount or mounting structure to the water tank/tower at a tank/tower manufacturer-approved location. Such locations may include, but are not limited to, one of the following:

- Grounding stud or bus bar attached to the tank/tower using capacitive discharge welding (or other techniques approved by the tank manufacturer).
- Exothermic weld to tank/tower manufacturer-supplied tab.
- Other location approved by the tank/tower manufacturer and/or water utility.

Antenna transmission lines and other communications cables with an outer metallic shield **shall** bond to the tank/tower at the top and at the bottom. Bonding at the top of the tank/tower can be made directly to the antenna mounting structure or to the bonding point described previously. Bonding at the bottom of the tank/tower can be made at the same location as the communications building/shelter grounding electrode system bond to the tank/tower or using similar techniques.

Figure 4-111 shows a typical water tank/tower installation.

**IMPORTANT**

Before any type of welding is performed on a water tank/tower, appropriate permissions shall be obtained from the water utility and/or tank/tower manufacturer.

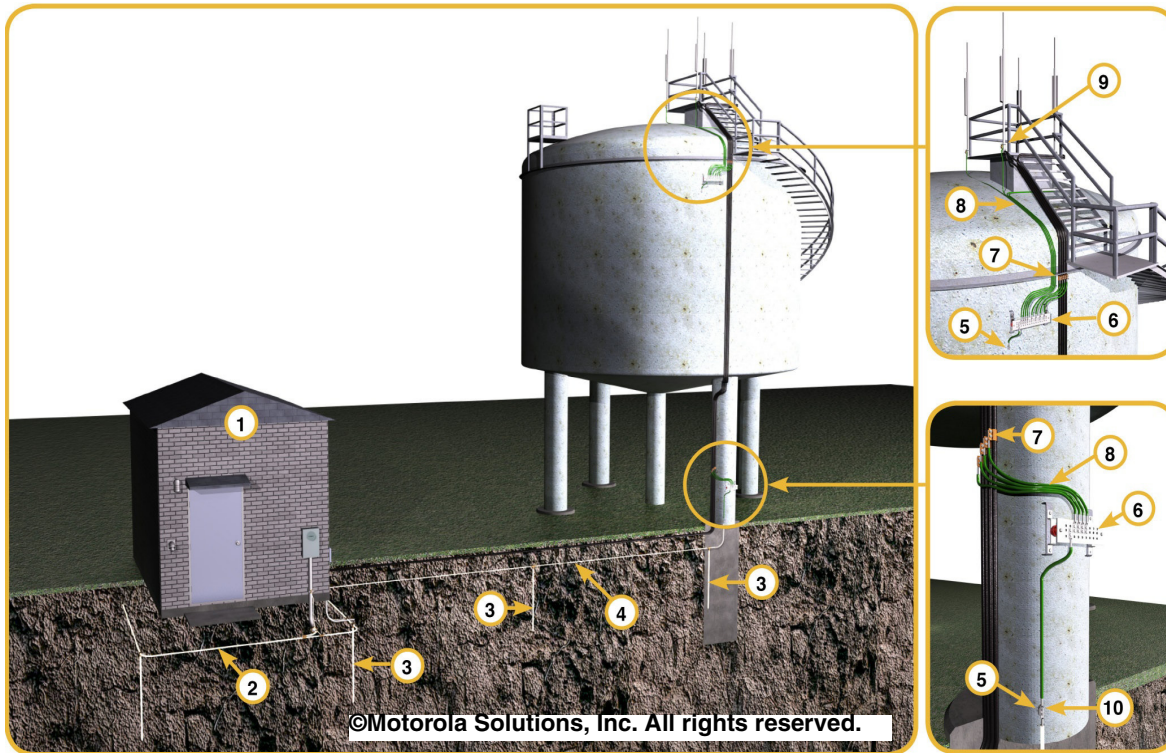

1	COMMUNICATIONS SHELTER
2	TINNED COPPER GROUND RING
3	STAINLESS STEEL OR GALVANIZED GROUND RODS
4	TINNED COPPER CONDUCTOR BONDING WATER TOWER
5	EXOTHERMIC WELD OR GROUNDING STUD ATTACHED USING CAPACITIVE DISCHARGE WELDING AS APPROVED BY TANK MANUFACTURER.
6	TINNED COPPER BUS BAR
7	COAX CABLE GROUNDING KIT
8	GREEN JACKETED BONDING CONDUCTOR
9	BOND ANTENNA MASTS TO THE GROUNDING BUS BAR
10	BOND BUS BAR AT SAME POINT / STUD AS THE BOND FROM BUILDING GROUND LOOP

Figure 4-111 Typical Water Tank/Tower Installation

4.14 Special Situations

Site conditions such as limited area and high (poor) soil resistivity may require special consideration for effective grounding and bonding. Methods for achieving effective grounding and bonding in some special situations are described in the following sections. Consultation with Motorola Solutions Engineering or other engineering firm may be required in some situations.

4.14.1 Rooftop Communications Sites

A rooftop communications site is a communications shelter/building installed on a rooftop or a rooftop penthouse used as a communications equipment room. The rooftop communications shelter/building/penthouse equipment room **shall** contain an internal bonding and grounding system with all equipment bonded and grounded as described in Chapter 5, “Internal Bonding and Grounding (Earthing)”. The rooftop communications site internal bonding and grounding system and External Ground Bus bar (EGB) (where applicable) **shall** be bonded to earth using methods described in this section.

Rooftop communications sites are typically grounded and bonded using effectively grounded structural building steel (metal frame/framework). Where effectively grounded structural building steel (metal frame/framework) is not available, some other effective means of grounding and bonding **shall** be used. See TIA-607-C, section C.2.6, for more information.

**IMPORTANT**

Consultation with Motorola Solutions Engineering or other engineering firm may be required for rooftop communication site grounding and bonding. The building owner and/or Authority Having Jurisdiction shall approve the communications site grounding/bonding system.

Some available options for grounding and bonding a rooftop communications site are as follows:

- Bonding to at least two down-conductors of an existing lightning protection system using conductors sized the same as the lightning protection system. Ensure a downward sloping path to earth.
- Bonding to at least two down-conductors of an existing rooftop tower grounding system using conductors sized according to Table 4-5. See “Grounding (Earthing) Rooftop Mounted Tower Structures” on page 4-119 for rooftop tower grounding information.
- Installation of at least two down-conductors and bonding to the building’s common grounding electrode system. When installing down conductors, the following **shall** be observed:
 - The down-conductors **shall** be sized according to Table 4-5, or lightning protection system conductors may be used (preferred method). Where used, the lightning protection system conductors **shall** be sized according to building height as shown in Table 4-3 and Table 4-4. The lightning protection system conductors may be copper, tinned-copper or aluminum, as appropriate for the site specific conditions (see “Down-Conductors” on page 4-40).
 - Each down conductor **shall** terminate to a grounding electrode or grounding electrodes, such as a small ground ring (see Figure 4-112) or multiple parallel ground rods in a straight line, as needed to achieve the grounding electrode system resistance design goal. See “Grounding (Earthing) Electrode System Resistance Requirements” on page 4-76.
 - The grounding electrodes **shall** bond to the building’s common grounding electrode system. See “Common Grounding” on page 4-6.
- Bond all nearby metallic piping systems, conduits and other metallic objects that are within 2 m (6 ft) of any metallic portion of the rooftop communications site or down conductors. In high lightning geographic areas, bonding should include any metallic objects within 3 m (10 ft). See “Metallic Objects Requiring Bonding” on page 4-101. Bonding of the objects can be made to a nearby bus bar that is bonded to the down-conductor(s) or can be made directly to the down-conductor(s).

**IMPORTANT**

If a supplemental grounding electrode system is installed, it shall be bonded to the existing building grounding electrode system. See “Common Grounding” on page 4-6.

**IMPORTANT**

Where an existing lightning protection system is used for grounding and bonding a rooftop communications site, ensure the down-conductors used maintain a downward sloping path and are effectively connected to earth.

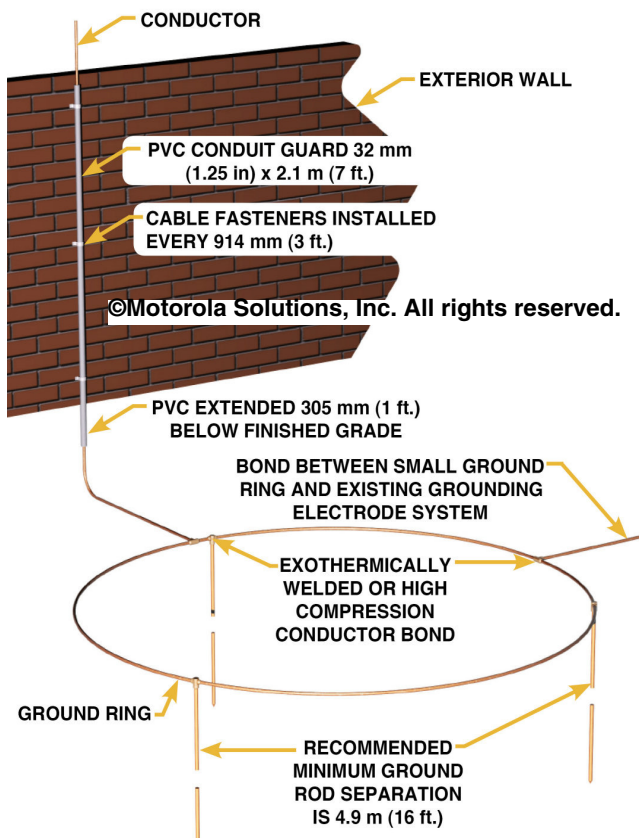

Figure 4-112 Small Ground Ring Installation



NOTE

In order to maintain maximum efficiency of parallel ground rods in a small ground ring installation, the ground rods **shall** be separated from one another as much as practicable (ideally by twice the length of the individual ground rods). See Figure 4-6. This requirement only applies to small ground rings installed in the context of this section. It does not apply to building and tower ground rings where a ground rod is required every 3 m to 4.5 m (10 ft to 15 ft).

4.14.2 Sites With Limited Space for the Grounding Electrode System

Some sites, such as locations in metropolitan areas or areas close to adjacent buildings or property lines, have very little space available for installing a grounding electrode system. One solution for achieving an acceptable grounding electrode system that meets the resistance design goal requirements defined in this chapter may be to install a grounding electrode grid system using all available space on the property.

A grounding electrode grid system consists of grounding electrodes, typically rods, installed in a grid pattern. The grounding electrodes are equally spaced and connected underground with a grounding conductor. See MIL-HDBK-419A for additional information. Requirements for a grounding electrode grid system are as follows:

- The grounding electrodes **shall** meet the specifications and installation requirements of “Grounding (Earthing) Electrodes” on page 4-8.
- Grounding conductors used to connect the grounding electrode **shall** meet the specifications and installation requirements of “Grounding (Earthing), Bonding and Down-Conductors” on page 4-37. Where practicable, the grounding conductors **shall** be buried at least 762 mm (30 in.) deep or below the frost line, whichever is deeper.
- Grounding conductors **shall** be bonded together where they intersect; this is typically completed at a ground rod or other grounding electrode.

- Bonding of all components **shall** use exothermic welding or listed irreversible high-compression fittings. See “Bonding to the External Grounding and Bonding System” on page 4-57.

See Figure 4-113 for an example of a grounding electrode grid system for an available area of 9.1×9.1 m (30×30 ft), with all ground rods separated by 3 m (10 ft).

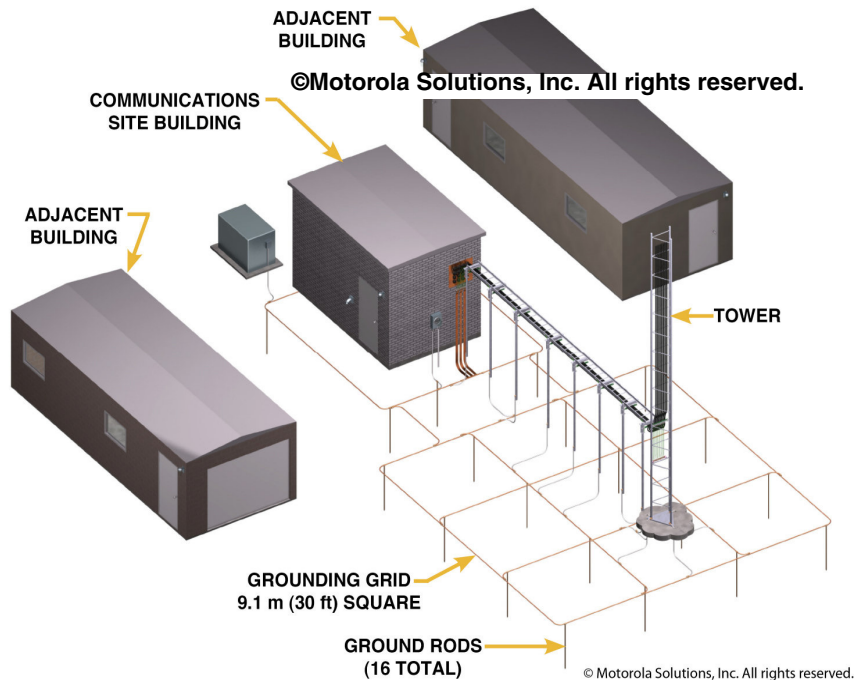

Figure 4-113 Typical Grounding Grid

See “Interpreting Test Results” on page B-11 to determine if the desired resistance to earth can be achieved using different rod lengths and/or separation. If the resistance to earth cannot be achieved using standard rods, electrolytic rods should be considered. Burying the grounding conductors in at least 152 mm (6 in.) of grounding electrode encasement material should also be considered as a method of improving the resistance to earth (see “Grounding (Earthing) Electrode Encasement Materials” on page 4-35).



NOTE

In shallow topsoil conditions, the grounding electrode grid system described previously may utilize ground plates instead of ground rods. Wire mesh may be another option (see “Wire Mesh” on page 4-32).

In some metropolitan areas with limited access to the earth due to exterior coverings such as sidewalks, pavement or concrete, cutting or coring of the coverings may be required in order to properly install the grounding electrode system components. Consultation with Motorola Solutions Engineering or other engineering firm may be required for these types of sites.

4.14.3 Towers with Limited Space for a Ground Ring

Towers installed close to a building may not have adequate space for a complete tower ground ring or for ground rods spaced properly to achieve the resistance requirements of the site. Depending on the available space, the tower can be grounded using multiple parallel rods and/or ground radials. See “Radial Grounding Conductors” on page 4-28 and Figure 4-114.

See “Interpreting Test Results” on page B-11 to determine the number of rods and rod spacing required to achieve the resistance requirements of the site.

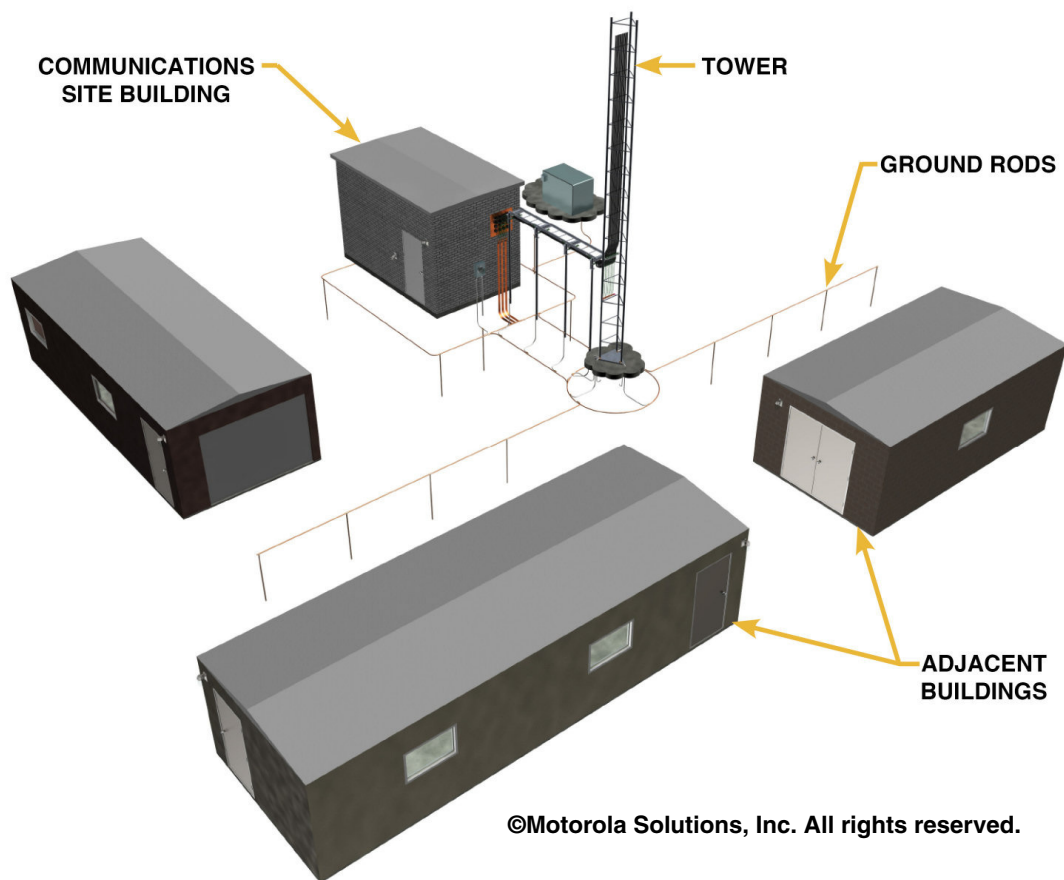

Figure 4-114 Typical Linear Grounding Electrode System

4.14.4 Stone Mountaintops

Some sites are located on mountaintops because of the RF propagation characteristics. Special designs are needed for sites with little or no topsoil. Consultation with Motorola Solutions Engineering or other engineering firm may be required for such sites. Reasonable attempts should be made to use as many options as needed to meet the grounding electrode system resistance design goal requirements and to ensure adequate equal potential bonding at the site. Some options for an effectively grounded and bonded site are as follows:

- Installation of concrete-encased electrodes during new construction. See “Concrete-Encased Electrodes” on page 4-23.
- Installation of wire mesh around the building and tower. The wire mesh and installation **shall** meet the requirements of “Wire Mesh” on page 4-32. See Figure 4-115.
- Installation of ground rings around the building and tower. The ground rings **shall** be secured to the rock surface at intervals not exceeding 91 cm (3 ft), using appropriate fasteners. A conductive-type concrete may also be used to protect and secure the ground rings. See “External Building and Tower Ground Ring” on page 4-25 and “Grounding (Earthing) Electrode Encasement Materials” on page 4-35. Additional electrodes, such as wire mesh, should be used in this instance. See “Wire Mesh” on page 4-32 and Figure 4-115.
- Installation of radial grounding conductors radiating away from the tower and building. The radial grounding conductors **shall** be secured to the rock surface at intervals not exceeding 91 cm (3 ft), using appropriate fasteners. Conductive-type concrete may also be used to protect and secure the radial grounding conductors (see IEEE 1692-2011, section 8.3). See “Radial Grounding Conductors” on page 4-28.

- Installation of radial conductors as described previously and extending down to a lower area where there is usable soil for the installation of vertical ground rods (or other effective grounding electrodes). The radial conductors **shall** be sized according to length as shown in Table 4-5, or a listed Class II lightning protection system conductor may be used (see “Down-Conductor Sizing” on page 4-40). If a lightning protection system grounding conductor is used on a mountain top site, only copper or tinned-copper conductors **shall** be used. See “Ground Rods” on page 4-12 and Figure 4-116.
- Installation of radial conductors as described previously and extending down to a lower area where there is usable soil for the installation of vertical ground plates. The radial conductors **shall** be sized according to length as shown in Table 4-5, or a listed Class II lightning protection system conductor may be used (see “Down-Conductor Sizing” on page 4-40). If a lightning protection system grounding conductor is used on a mountain top site, only copper or tinned-copper conductors **shall** be used. See “Ground Plate Electrodes” on page 4-21 and Figure 4-117.
- Installation of copper strap radial grounding conductors on the surface of the rocks and radiating in all directions away from the building and tower. The copper straps may be covered with top soil (native or imported) and/or a grounding electrode encasement material, such as conductive concrete or otherwise secured to the rock surface. Each copper strap radial should be a different length ($\pm 5\%$) to help prevent ringing of the tower during a lightning strike.

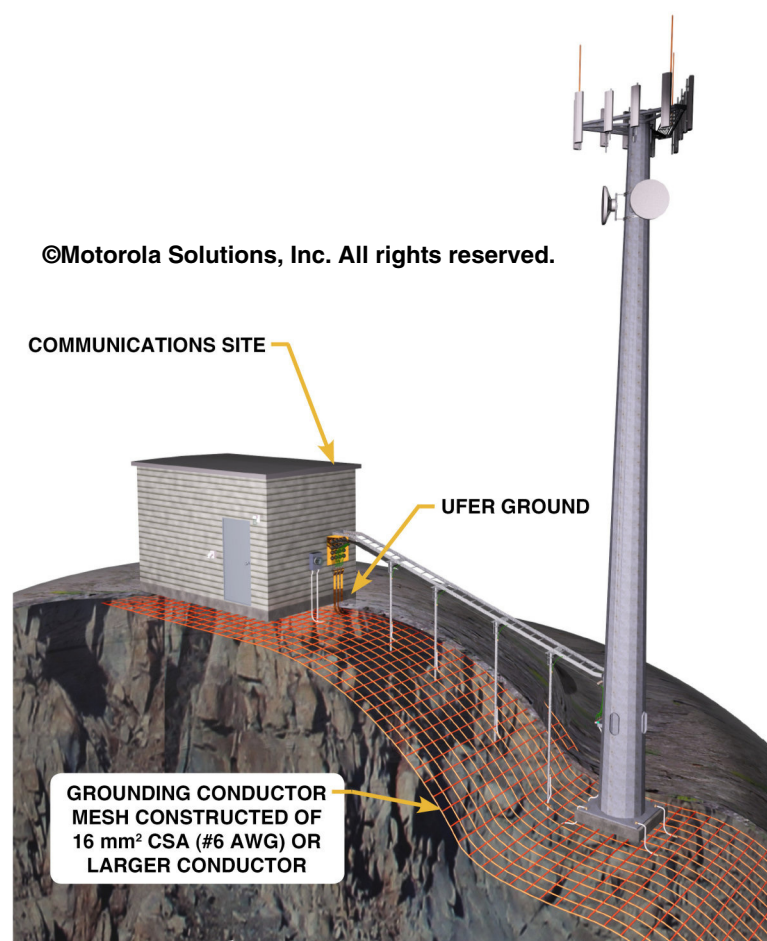

Figure 4-115 Installation of Wire Mesh on Stone Mountaintop Site or Site with Shallow Topsoil

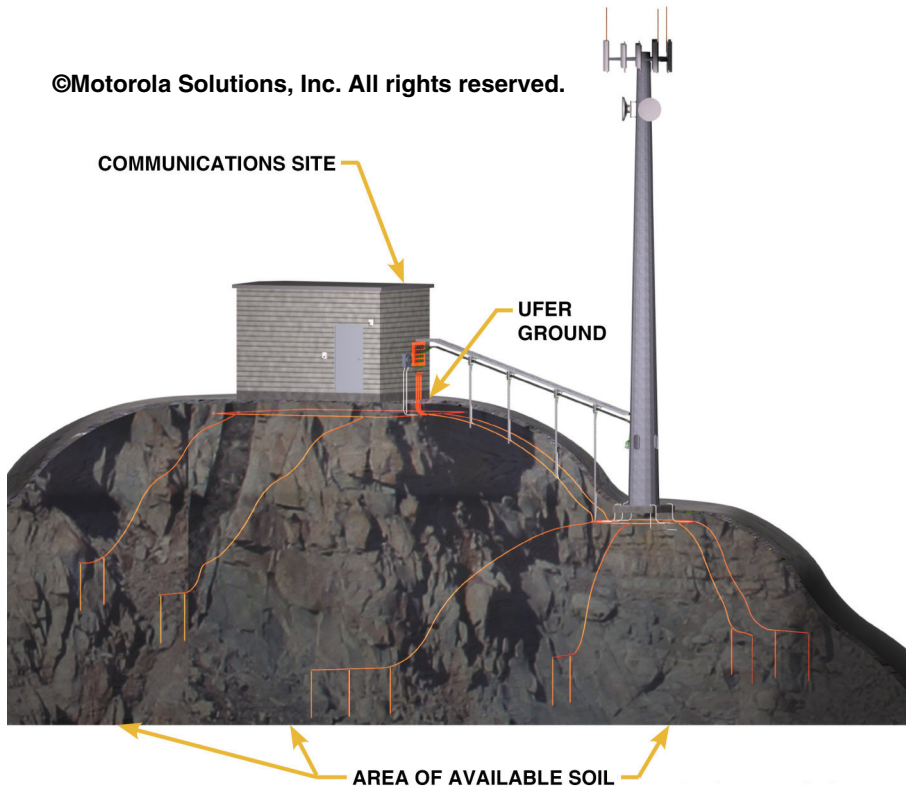

Figure 4-116 Installation of Radials and Ground Rods on Stone Mountaintop Site



Figure 4-117 Installation of Radials and Ground Plates on Stone Mountaintop Site or Site with Shallow Topsoil

**IMPORTANT**

At sites such as stone mountaintops, where it is difficult to achieve an effective grounding electrode system, the need for single-point grounding, equal potential bonding of all equipment (internal and external), and Surge Protective Devices (SPD) on all input/outputs is of paramount importance.

**NOTE**

The concept of drilling holes in solid rock to insert a ground rod surrounded by a grounding electrode encasement material is generally considered to be ineffective and should not be used without additional grounding electrode system components. Solid rock is no more conductive in a hole than on the surface. Radial grounding conductors encased in a grounding electrode encasement material, such as conductive concrete, would be more effective and more economical.

**IMPORTANT**

Radial conductors alone should not be relied on for an effective grounding electrode system and equipotential bonding. Other methods listed in this section, such as building and tower ground rings, wire mesh and concrete-encased electrodes, should also be used to help achieve an effective grounding electrode system.

4.14.5 Shallow Topsoil Environments

Some sites are located in areas where bedrock is near the surface or where the topsoil is less than 305 mm (1 ft) deep. These areas require installation of specialized grounding electrode systems and may require the support of Motorola Solutions Engineering or other engineering firm.

Requirements and recommendations for grounding electrode systems in areas with shallow topsoil are provided in this section. Reasonable attempts should be made to use as many options as needed to meet the grounding electrode system resistance design goal requirements of the site. See NFPA 780-2017, section 4.13.8.1, and associated subsections for additional information. Some options to help achieve an effectively grounded and bonded site are:

- Installation of concrete-encased electrodes during new construction. See “Concrete-Encased Electrodes” on page 4-23.
- Installation of ground rings around the building and tower, with the ground rings buried as deeply as the soil will allow. The ground rings should be encased in a grounding electrode encasement material. A conductive concrete may be the best grounding electrode encasement material for use in shallow topsoil environments, because the conductive concrete does not require a topsoil covering for protection. See “External Building and Tower Ground Ring” on page 4-25.
- Installation of a grounding electrode grid system, using ground plates instead of vertical ground rods. The grounding conductors and ground plates **shall** be buried as deep as the soil will allow. The grounding conductors should be encased in a grounding electrode encasement material. A conductive concrete may be the best grounding electrode encasement material for use in shallow topsoil environments, since the conductive concrete would not require a covering of topsoil for protection. See “Sites With Limited Space for the Grounding Electrode System” on page 4-136 and Figure 4-113 for additional information on grounding electrode grid systems. See “Ground Plate Electrodes” on page 4-21 for additional ground plate installation requirements.
- Installation of wire mesh throughout the site, in addition to the building and tower grounding rings. See “Wire Mesh” on page 4-32. See Figure 4-115 for a wire mesh installation example.
- In addition to the building and tower ground rings, installation of horizontal ground rods radiating away from the building and tower. See Figure 4-118.

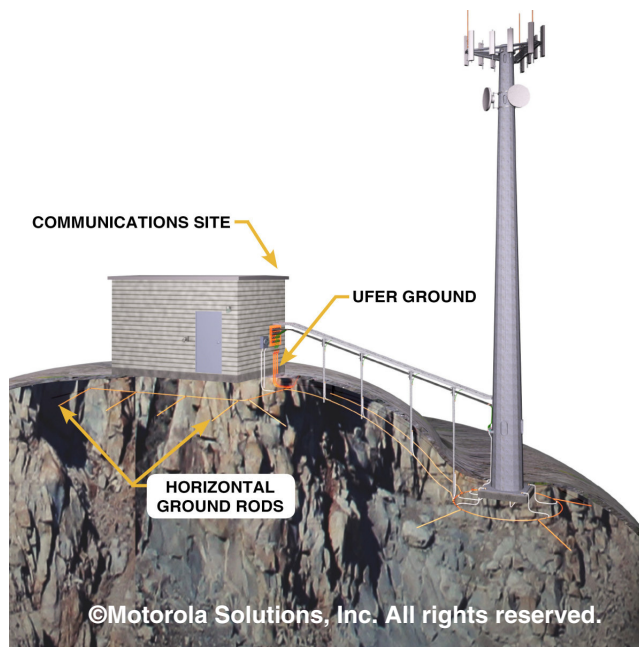

Figure 4-118 Installation of Horizontal Ground Rods in Shallow Topsoil Conditions

- Installation of ground plates along the length of the ground rings instead of vertical ground rods. The ground plates should be encased in a grounding electrode encasement material. See “Ground Plate Electrodes” on page 4-21, “Grounding (Earthing) Electrode Encasement Materials” on page 4-35 and Figure 4-119.

©Motorola Solutions, Inc. All rights reserved.



Figure 4-119 Installation of Ground Plates in Shallow Topsoil Conditions

- Installation of electrolytic ground rod systems. See “Electrolytic Ground Rods” on page 4-19.

- Installation of building and tower radial grounding conductors in a trench extending away from the building and tower. The radial grounding conductors **shall** be buried as deep as the soil will allow. The radial grounding conductors **shall** bond to the ground rings using exothermic welding or listed irreversible high-compression fittings.
- The radial grounding conductors should be encased in a grounding electrode encasement material. A conductive concrete may be the best grounding electrode encasement material for use in shallow topsoil environments, since the conductive concrete would not require a covering of topsoil for protection (see IEEE 1692-2011, section 8.3). Each radial grounding conductor may have ground plates installed every 1.8 to 4.9 m (6 to 16 ft) along its length. See Figure 4-120.

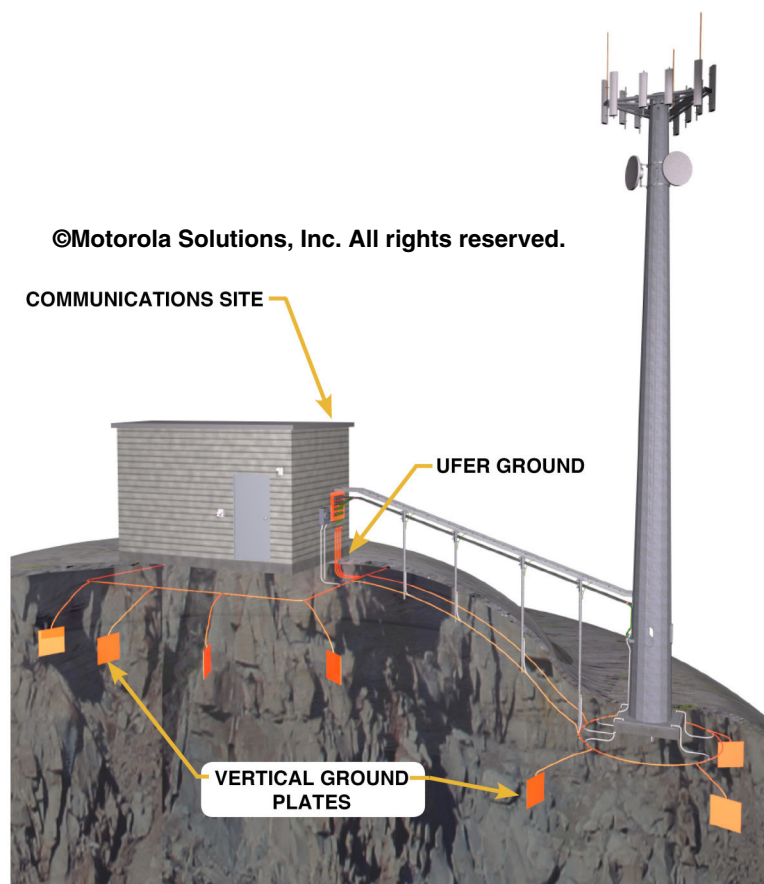

Figure 4-120 Installation of Radials and Ground Plates in Shallow Topsoil Conditions

4.14.6 Sand, Coral or Limestone Environments

Sites with very high soil resistivity, such as sites with sand, coral and limestone, may require special techniques in order to achieve an effectively grounded and bonded site. Consultation with Motorola Solutions Engineering or other engineering firm may be required at these types of sites. Some options to help achieve an effectively grounded and bonded site are as follows:

- Installation of concrete-encased electrodes during new construction. See “Concrete-Encased Electrodes” on page 4-23.
- In addition to building and tower ground rings, installation of radial grounding conductors with vertical ground rods throughout the available property. See “Radial Grounding Conductors” on page 4-28 and “Ground Rods” on page 4-12.
- Encasing all components in a grounding electrode encasement material can further increase the effectiveness of the grounding electrode system.
- Installation of electrolytic ground rod systems instead of standard ground rods. See “Electrolytic Ground Rods” on page 4-19.
- In addition to the building and tower ground rings, installation of a grounding electrode grid system throughout the site. See “Sites With Limited Space for the Grounding Electrode System” on page 4-136.

- In addition to the building and tower grounding rings, installation of wire mesh throughout the site. See “Wire Mesh” on page 4-32.
- Using multiple large copper plates (0.88 to 1.8 m² (10 to 20 ft²)) buried to an optimal depth of 1.5 m to 2.4 m (5 to 8 ft). The plates are placed vertically on edge and bonded to the grounding electrode system using exothermically welded 35 mm² csa (#2 AWG) solid copper conductor. Placing the plates on vertical edge allows the plates to be buried with a minimum of excavation and may make it possible to obtain more surface area contact with the soil when backfilling. The use of a number of well-placed ground plates in parallel is preferred to placing longer rows of ground plates (IEEE 142-2007, section 4.2.4). Encasing the ground plates in a grounding electrode encasement material can further increase the effectiveness of the grounding electrode system.

4.14.7 Arctic Environments

It may be difficult to achieve an effective low resistance grounding electrode system at sites located in arctic regions (or similar cold climates). In these cases, consultation with Motorola Solutions Engineering or other engineering firm is recommended. The primary difficulty in achieving an effective grounding electrode system in arctic regions is making good contact with frozen high-resistivity soils. In areas of frozen high-resistivity soils, optimum grounding can only be accomplished through special attention to surface and subsurface terrain. The resistivity of frozen soils can be 10 to 100 times greater than in the unfrozen state; therefore, seasonal changes in temperature and moisture greatly affect the grounding electrode system’s resistance to earth. See Appendix B for additional information regarding soil resistivity changes as a function of temperature and moisture. See MIL-HDBK-419-A Volume I, section 2.11.1, for additional information.

Seasonal freezing accounts for an increase in grounding electrode system resistance. Because frozen soil has a high resistivity, then providing larger electrodes reduces the resistance to earth. In arctic areas that generally have very shallow surface thaw layers, horizontal rods or conductors provide an equivalent resistance to earth and may be easier to install than driven rods. Soil conditions at the site and the economics of installation determine whether to install multiple electrodes, a single deep-driven rod or horizontal conductors. See MIL-HDBK-419-A Volume I, section 2.11.1, for additional information.

An option for an effective grounding electrode system may be to install electrolytic ground rods encased in a grounding electrode encasement material. See “Electrolytic Ground Rods” on page 4-19 and “Grounding (Earthing) Electrode Encasement Materials” on page 4-35. See MIL-HDBK-419-A Volume I, section 2.11.2, for additional information.

Internal Bonding and Grounding (Earthing)

This chapter provides requirements for bonding and grounding (earthing) communications site equipment within a facility. The following topics are included:

- “Introduction to Internal Bonding and Grounding (Earthing)” on page 5-1
- “General Application” on page 5-3
- “Common Grounding (Earthing)” on page 5-6
- “Single-Point Grounding (Earthing) and the Single-Point Entry Window” on page 5-7
- “Electrical Service Grounding and Entrance Point” on page 5-8
- “Internal Bonding System Components and Installation Requirements” on page 5-9
- “Bonding and Grounding Infrastructure Subsystems” on page 5-49
- “Connection Methods for Internal Bonding and Grounding (Earthing) System” on page 5-64
- “Bonding Equipment to Internal Bonding and Grounding (Earthing) System” on page 5-79
- “Bonding and Grounding (Earthing) for Specific Site Types” on page 5-124
- “Testing the Internal Bonding and Grounding (Earthing) System” on page 5-140



NOTE

Throughout this chapter the terms “grounding” and “earthing” are used interchangeably.



NOTE

Where a section is referenced in the chapter, it **shall** be assumed the reference includes all applicable subsections.

5.1 Introduction to Internal Bonding and Grounding (Earthing)

Proper bonding and grounding of communications equipment is essential for personnel safety, system reliability and system availability. With increases in circuit density and the advent of lower-voltage integrated circuit devices, communications equipment is more vulnerable than ever to damage resulting from lightning activity, power line anomalies and electrostatic discharge. Inadequate or improper equipment bonding and grounding can permit a difference of electrical potential to exist between system components, which may result in injury to personnel, system failure and equipment damage.

The requirements and guidelines in this chapter are derived from a compilation of local and national codes, widely accepted industry codes and standards and good engineering practices. Such codes and standards are from, but not limited to, the following standards organizations:

- Alliance for Telecommunications Industry Solutions (ATIS)
- American National Standards Institute (ANSI)
- BICSI®
- Institute of Electrical and Electronics Engineers (IEEE)
- International Electrotechnical Commission (IEC)
- International Telecommunication Union (ITU)
- National Fire Protection Association (NFPA)

- Telecommunications Industry Association (TIA)
- Underwriters Laboratories (UL)
- United States Department of Defense (DoD)
- United States Federal Aviation Administration (FAA)
- United States National Weather Service (NWS)

References to the specific industry codes and standards on which this chapter is based are provided throughout. The requirements and guidelines in this chapter are provided to enhance personnel safety and equipment reliability.

Safety of personnel and protection of sensitive electronic equipment from ground faults, lightning, ground potential rise, electrical surges, power quality anomalies and electrostatic discharge is of utmost importance at any communications site. Though unexpected electrical events such as lightning strikes and power surges cannot be prevented, this chapter provides design and installation information on communications site internal bonding systems that may help to mitigate damages caused by these types of events.

**CAUTION**

Grounding and bonding alone are not enough to adequately protect a communications site. Transient Voltage Surge Suppression (TVSS) techniques, using appropriate Surge Protective Devices (SPD), **shall** be incorporated at a communications site in order to provide an adequate level of protection. See Chapter 7, “Surge Protective Devices”, for details and requirements.

**WARNING**

The AC power system ground SHALL be sized appropriately for the electrical service and SHALL be approved by the Authority Having Jurisdiction (AHJ).

An internal bonding and grounding system **shall** have low electrical impedance, with conductors large enough to withstand high fault currents. The lower the grounding system impedance, the more effectively the grounding electrode system can dissipate high-energy impulses into the earth.

All site development and equipment installation work **shall** comply with all applicable codes in use by the AHJ. Grounding systems **shall** be installed in a neat and workmanlike manner (ATIS-0600313.2013, section 11.1; IEC 60364-1:2005, section 131; NFPA 70-2017, Article 110.12; ANSI/NECA 1-2015; and NFPA 780-2017, section 1.5.1). Where conflicting, the more stringent standard **shall** be followed. Government and local codes **shall** take precedence over the requirements of this manual.

**IMPORTANT**

Local codes and other codes enforced by the AHJ shall take precedence over the requirements of this manual. The more stringent requirement shall be followed.

Unusual site conditions may require additional effort to achieve an effectively bonded and grounded site. In these instances, consultation with Motorola Engineering or with an engineering firm specializing in grounding system design is recommended.

Some of the benefits of a properly designed and installed low-impedance grounding system are described in this section. See ATIS-0600333.2013, section 4; IEEE 1100-2005, section 3.3.1; and NFPA 70-2017, Article 250.4 for additional information.

- Helps dissipate the overvoltages caused by lightning.
- Limits potential differences between conductive surfaces caused by electrical disturbances such as electrical power faults, lightning strikes and electrostatic discharges.
- Provides fault current paths of sufficient current carrying capacity and low impedance that allow overcurrent protection devices to quickly clear the circuit.
- Limits the voltage caused by accidental contact of the site AC supply conductors with conductors of higher voltage.

- Enhances the immunity of the communications equipment installation to noise, electromagnetic interference and electrostatic discharges.
- Reduces noise and electromagnetic interferences produced by communications equipment.
- Contributes to reliable equipment operation.
- Provides a common signal reference ground.

**NOTE**

Grounding of communication equipment through the Alternating Current (AC) power cord does not meet the intent of this installation standard and other related industry standards. While the AC power cord typically contains an Equipment Grounding Conductor (EGC), the integrity of the electrical distribution system EGC ground path to the electrical service (power) ground cannot be easily verified (see TIA-607-C and IEEE 1100-2005 for more information).

5.2 General Application

The basic design, principles and components of an internal bonding and grounding system specified in this chapter are applicable to buildings of differing design, structure type and size. Such buildings may include, but are not limited to, the following:

- Outdoor equipment cabinet
- Dedicated communications building or shelter (see Figure 5-4)
- Multi-story large building and high-rise building (see Figure 5-1)
- Single-story large building (see Figure 5-2)
- Single-story smaller building (see Figure 5-3)

**NOTE**

Each Secondary Bonding Bar (SBB) shown in Figure 5-1 and Figure 5-2 effectively serves as a Primary Bonding Bar (PBB) for the room where it is installed.

Within a building or structure, the bonding and grounding system infrastructure originates at the electrical service ground and extends throughout the building as required.

The internal bonding and grounding system for an RF site typically includes, but is not limited to, the following major components (see Figure 5-4 for an example):

- Master Ground Bus Bar (MGB) or Primary Bonding Bar (PBB)
- Subsystem Ground Bus Bar (SSGB) or Secondary Bonding Bar (SBB)
- Rack Ground Bus Bar (RGB) or Rack Bonding Bar (RBB)
- Network-Equipment Bonding Bar (NBB)
- Internal Perimeter Ground Bus Conductor (IPGB) or Internal Perimeter Bonding Bus Conductor (IPBB)

These telecommunications bonding and grounding components are intended to work with a building's telecommunications pathways and spaces, installed cabling and administration system. See TIA-607-C for more information.

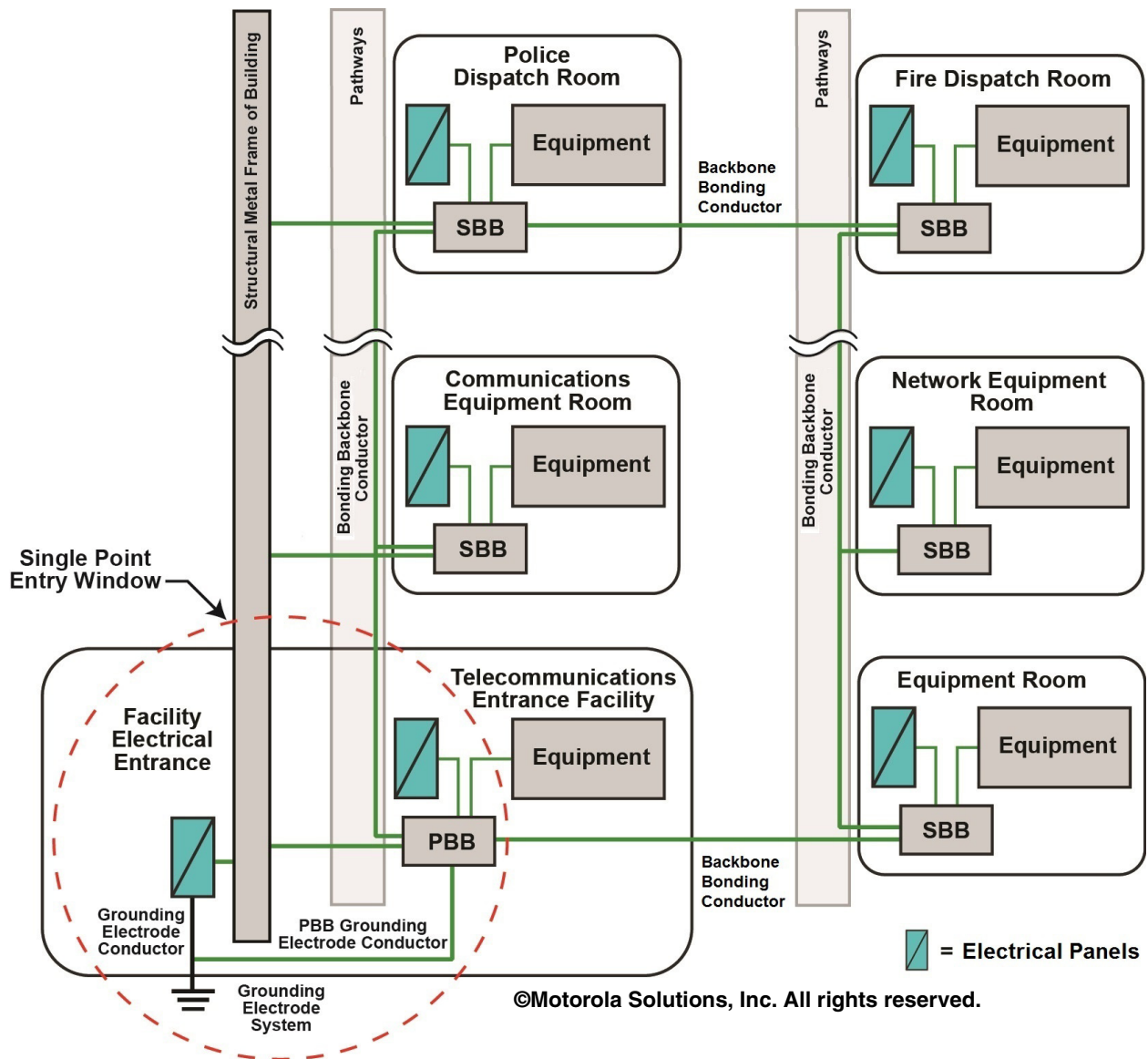

Figure 5-1 Example of Internal Bonding and Grounding System for Multi-Story Large Commercial Building

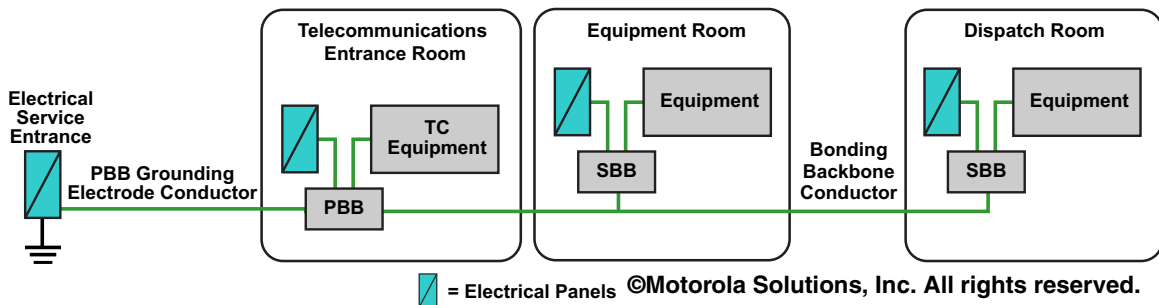

Figure 5-2 Example of Internal Bonding and Grounding System for Single-Story Large Commercial Building

©Motorola Solutions, Inc. All rights reserved.

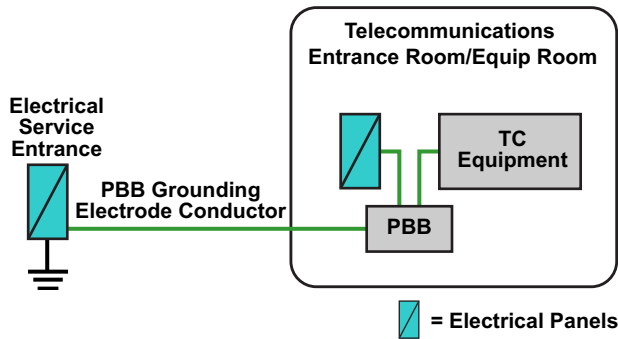

Figure 5-3 Example of Internal Bonding and Grounding System for Single-Story Smaller Commercial Building

©Motorola Solutions, Inc. All rights reserved.

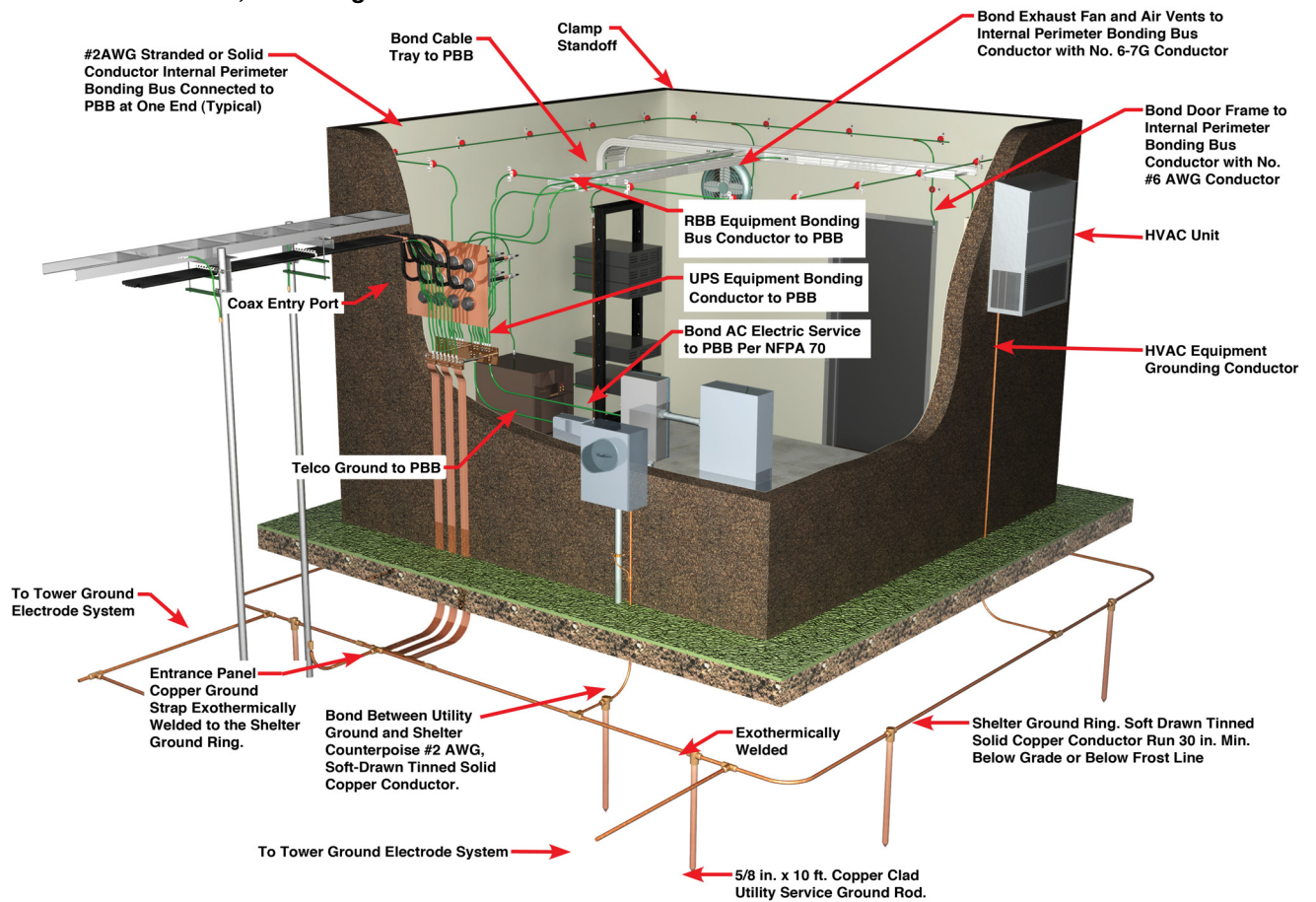

Figure 5-4 Example of Internal Bonding and Grounding System for Typical Dedicated Communications Shelter

5.3 Common Grounding (Earthing)

At a communications site, all grounding electrodes **shall** be bonded together to form a single grounding electrode system (see Figure 5-5). All grounding electrodes used for grounding of the power system, grounding of communications systems and grounding of lightning protection systems **shall** be effectively and permanently bonded together (IEEE 1100-2005, section 8.5). The AC power system ground, communications tower ground, lightning protection system ground, telephone system ground, exposed structural building steel, underground metallic piping that enters the facility and any other existing grounding system **shall** be bonded together to form a single grounding electrode system (ATIS-0600313.2013, section 7; ATIS-0600333.2013, section 5.1; ATIS-0600334.2013, section 5.3; IEC 62305-3:2010, section 6.2; ITU Earthing and Bonding Handbook, section 3.1; IEEE 1100-2005; NFPA 70-2017, Articles 250.58, 250.104, 250.106, 800.100, 810.21, 820.100 and 830.100; and NFPA 780-2017, section 4.14).

Underground metallic piping systems typically include water service, well castings located within 7.6 m (25 ft) of the structure, gas piping, underground conduits, underground liquefied petroleum gas piping systems and so on. Interconnection to a gas line **shall** be made on the customer's side of the meter (IEC 60364-5-54:2011, section 542.2.6 and Annex B; and NFPA 780-2017, section 4.14.6). See Chapter 6, "Power Sources", for additional information on grounding the electrical utility service to the facility grounding electrode system.

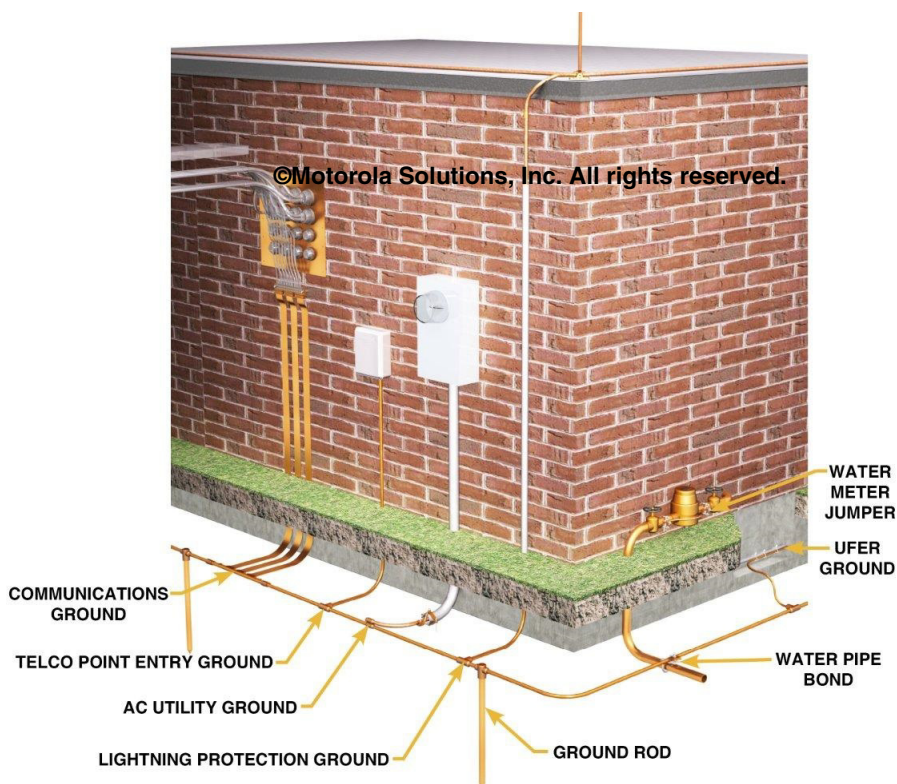

Figure 5-5 Example of Common Grounding

The objective of bonding and grounding system components to a single point is to minimize any difference of potential that may develop between individual components within the system and within the equipment site or area. To reach this objective, a low-impedance internal single point bonding system is required for all communications equipment, support equipment, power systems, and other items or materials located within the same facility.

5.4 Single-Point Grounding (Earthing) and the Single-Point Entry Window

Single-point grounding is the concept of bonding all equipment (communications equipment, ancillary support equipment, antenna transmission lines, surge protective devices and so on) in a communications building or shelter together to a common point (for example, the Master Ground Bus Bar) and bonding this common point to the grounding electrode system in one single point or location. The single point or location does not necessarily imply just one single grounding electrode conductor. Multiple grounding electrode conductors may exist for grounding different system components and/or utilities to the common grounding electrode system (for example, Master Ground Bus Bar, AC power, telephone and so on).

The primary requirement for single-point grounding is for all grounding electrode conductors to enter/exit the building in the same general location, forming a single-point entry window. Where practicable, the encompassing area of the single point entry window should fit within a sphere having a diameter of 2 m (6 ft) (see ATIS-0600333.2013, section 3.1.23). See Figure 5-6 for an example of the single-point entry window.

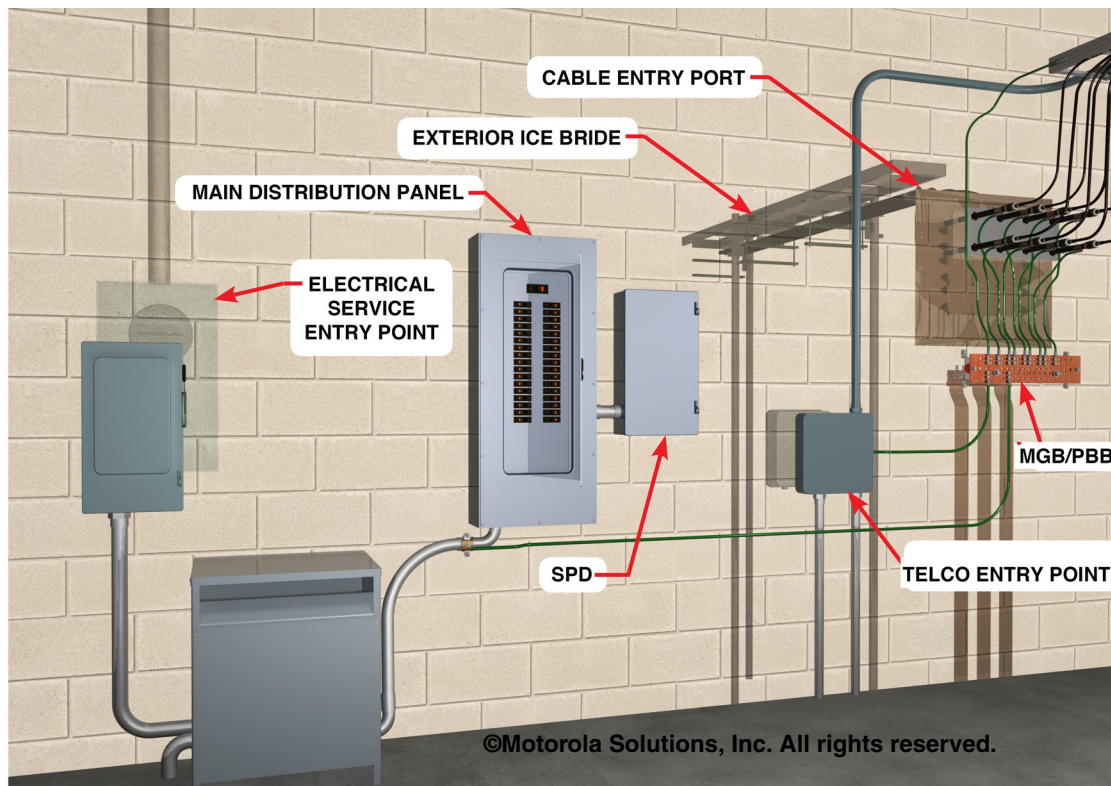

Figure 5-6 Single-Point Entry Window Example

The theory behind single-point grounding is that the electrical potential of all equipment in the building or shelter will rise and fall together in the event of a lightning strike (direct or nearby) or other electrical fault or disturbance. Single-point grounding will also help minimize current flow in the building or shelter during a lightning event or fault condition.

Single-point grounding is easily achieved at a dedicated communications shelter or small commercial building (for example, a small dispatch center), but may not always be practicable in larger or multi-story buildings. In cases where single-point grounding is not practicable for the entire building, the same concept is applied to each equipment room or area (see “Bonding and Grounding (Earthing) for Large and Multi-Story Commercial Building Installations” on page 5-128).

Where practicable, a single-point grounding system **shall** be established at all communications buildings and shelters. In larger and multi-story buildings where it is not practicable to establish a single-point grounding system for the entire building, a single-point grounding system **shall** be established in each communications equipment room or area.



IMPORTANT

In order to achieve true single-point grounding, all utilities and communications cables must enter the facility in the same general area.

5.5 Electrical Service Grounding and Entrance Point

The electrical service entrance is an integral part of the single point grounding system and should be located at the single point entry window. For optimum grounding and AC surge protective performance, the location of the neutral-ground bond should be within the single point entry window. See Chapter 6, “Power Sources”, for more information.



IMPORTANT

All bonding and grounding at a site references to the electrical service ground. The electrical service ground shall bond to the common grounding electrode system.



WARNING

The AC power system ground **SHALL** be sized appropriately for the electrical service and **SHALL** be approved by the Authority Having Jurisdiction (AHJ).

The grounding electrode conductor for the electrical service neutral-ground bond **shall** be established in the main disconnect and bonded to the common grounding electrode system as described within Chapter 4, “External Grounding (Earthing) and Bonding”, and Chapter 6, “Power Sources”. The main disconnect grounding electrode conductor **shall** meet all installation requirements of applicable local and jurisdictional electrical codes (NFPA 70-2017, Article 250.64). Figure 5-7 and Figure 5-8 provide examples of the grounding electrode conductors routing and bonding to the common grounding system.

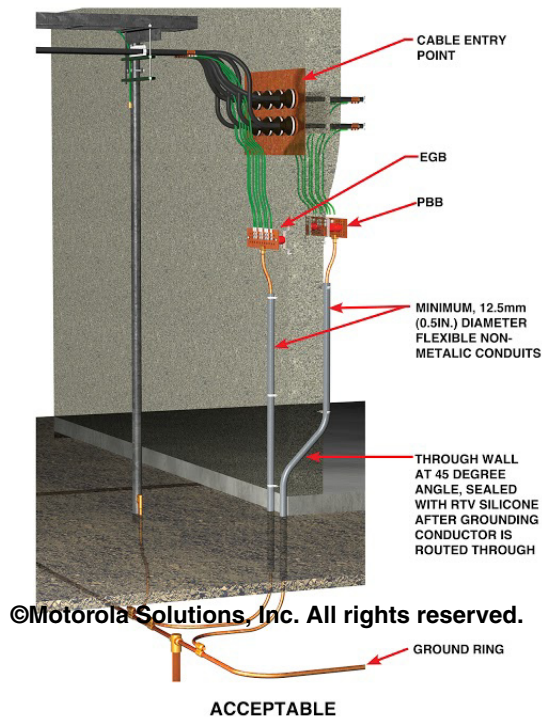

Figure 5-7 Routing and Protecting of PBB Grounding Electrode Conductor

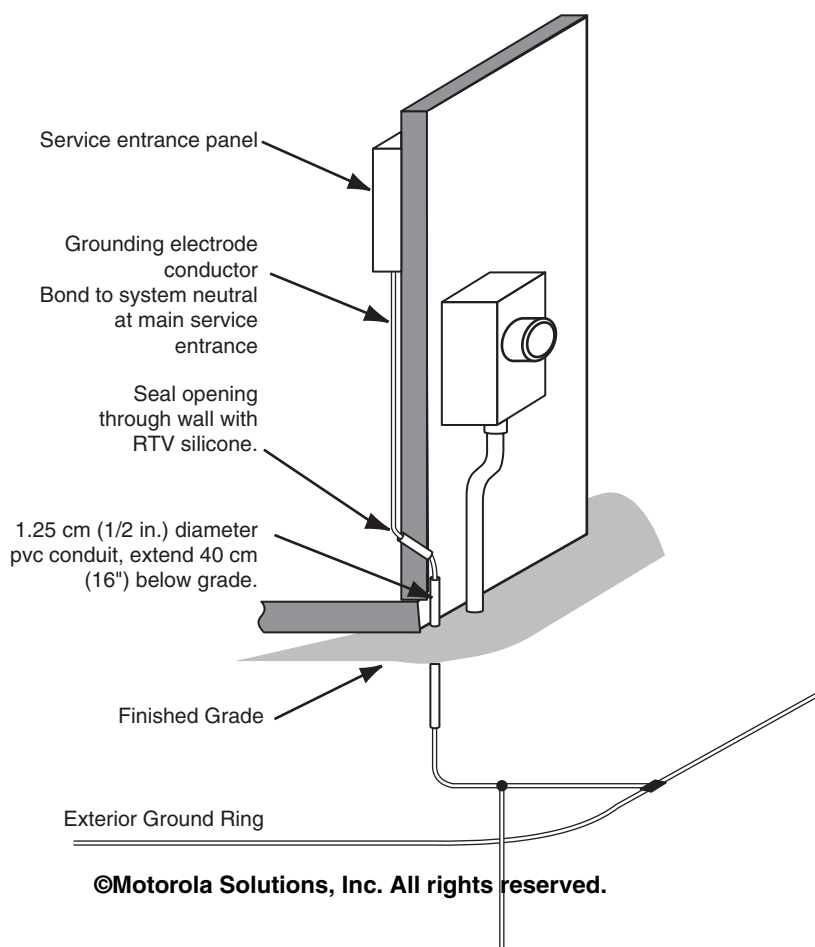
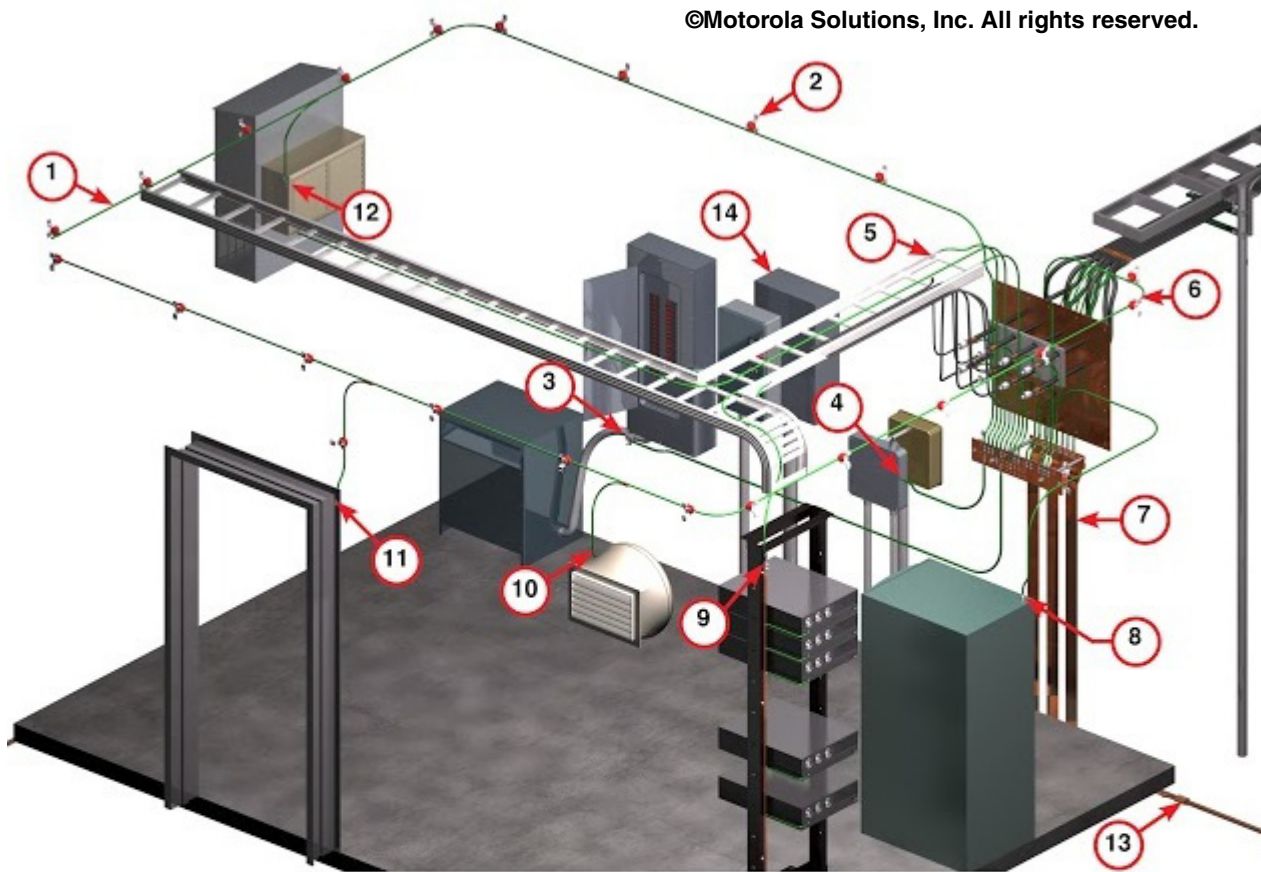

Figure 5-8 Routing of Electrical Grounding Electrode Conductor

5.6 Internal Bonding System Components and Installation Requirements

An effective low-impedance internal bonding and grounding system can be achieved through the use of the components listed in this section, all of which must be effectively bonded together so there is minimal difference in potential among them. Figure 5-9 shows the major components of a typical internal single-point bonding and grounding system, which are described in the following subsections:

- “Master Ground (Earth) Bus Bar or Primary Bonding Bar” on page 5-10
- “Integrated Panels and Cable Entry Ports” on page 5-15
- “Sub System Ground Bus Bar or Secondary Bonding Bar” on page 5-17
- “Rack Ground Bus Bar or Rack Bonding Bar” on page 5-27
- “Network-Equipment Bonding Bar” on page 5-32
- “Bonding and Grounding (Earthing) Conductors” on page 5-39



1	#2 AWG INTERNAL PERIMETER BONDING BUS CONNECTED TO THE PBB AT ONE END	8	UPS EQUIPMENT GROUND CONDUCTOR TO THE PBB
2	STANDOFF CLAMP WITH INSULATOR	9	EQUIPMENT BONDING BUS TO PBB
3	BOND AC ELECTRICAL SERVICE TO THE PBB	10	BOND EXHAUST FANS AND AIR VENTS TO INTERNAL PERIMETER BONDING BUS
4	BOND TELCO GROUND TO THE PBB	11	BOND DOOR FRAME TO INTERNAL PERIMETER GROUND BUS
5	BOND CABLE TRAY TO THE PBB	12	BOND HVAC TO IPBB
6	BOND IPBB TO PBB	13	SHELTER GROUND RING
7	ENTRANCE PANEL GROUND STRAPS EXOTHERMICALLY WELDED TO THE SHELTER GROUND RING	14	AC ELECTRICAL METER BOX

Figure 5-9 Typical Internal Bonding and Grounding System in a Standalone Shelter

5.6.1 Master Ground (Earth) Bus Bar or Primary Bonding Bar

The Primary Bonding Bar (PBB), previously referred to as the Master Ground Bus Bar (MGB), is the primary ground (earth) reference point inside the facility. The MGB/PBB interfaces the interior bonding system to the exterior grounding electrode system. The MGB/PBB provides a convenient internal bonding termination point and connection to the grounding electrode system. In other standards, the MGB/PBB may be referred to as a Building Principal Ground (BPG) or a Telecommunications Main Grounding Bus bar (TMGB) (see ATIS-0600313.2013, ATIS-0600333.2013, ATIS-0600334.2013 and TIA-607-C for more information).

**NOTE**

Throughout this chapter the terms Master Ground Bus Bar (MGB) and Primary Bonding Bar (PBB) are used interchangeably. In an effort to better align with national and international standards, Primary Bonding Bar (PBB) will be the preferred naming convention in this publication.

The PBB functions as the primary internal earth reference point and central attachment point for all equipment bonding conductors, bus conductors, bonding backbone conductors and communications/electronic equipment within the facility (see TIA-607-C). The PBB also serves as the central attachment point for Subsystem Ground Bus Bars (see TIA-607-C). Typically there should be only one PBB per building (TIA-607-C and ATIS-0600334.2013).

- A typical PBB with insulated mounting hardware is shown in Figure 5-10. A typical stand-alone equipment shelter internal bonding and grounding system is shown in Figure 5-9.
- A typical PBB installation in a small commercial building is shown in Figure 5-6.

The PBB **shall** be installed as close as practicable to the single point entry window of the facility (see “Single-Point Grounding (Earthing) and the Single-Point Entry Window” on page 5-7). The PBB **shall** bond to the common grounding electrode system of the site as described within this chapter. A single PBB **shall** be installed for the communications system within a shelter, building, room or equipment area as specified in the chapter. In facilities where RF transmission lines, electrical service and telecommunication cables enter at different locations, the PBB **shall** be located as described within this chapter. In all cases transmission lines, telecommunication cables and electrical service **shall** be effectively bonded to the PBB, and the PBB **shall** be effectively bonded to the grounding electrode system as described within this chapter.

**NOTE**

Large buildings or campuses with multiple power feeds may require special design considerations that are beyond the scope of this document. Consultation with Motorola Solutions Engineering or other engineering firm is recommended in these instances.

©Motorola Solutions, Inc. All rights reserved.

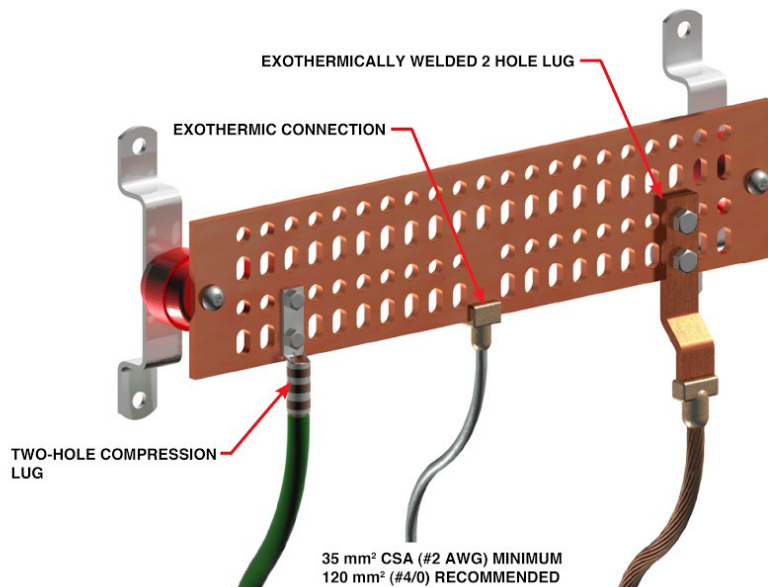

Figure 5-10 Typical Primary Bonding Bar (PBB) with Available Connection Methods

5.6.1.1 Primary Bonding Bar Specifications

Specifications for the Primary Bonding Bar (PBB) are as follows:

- The PBB **shall** be constructed and minimally sized according to Table 5-1.
- The PBB **shall** be designed for the purpose of grounding and **shall** be listed by a Nationally Recognized Testing Laboratory (NRTL) (see TIA-607-C).
- The PBB **shall** be sized according to the immediate application and consideration should be given to future growth of the site (TIA-607-C).

Table 5-1 PRIMARY BONDING BAR SPECIFICATIONS

Item	Specification
Listing Requirement (TIA-607-C)	Shall be listed by a Nationally Recognized Testing Laboratory (NRTL)
Material	Solid Copper or copper alloys having a minimum of 95% conductivity when annealed
Minimum Dimensions (TIA-607-C)	Height: 100 mm (4 in.) Thickness: 6.35 mm (0.25 in.) Length: Variable to meet the application requirements and allow for future growth. 305 mm (12 in.) is recommended as the minimum length
Mounting brackets	Suitable for the application and should provide a minimum 50.8 mm (2 in.) separation from the supporting surface
Insulators	Should be polyester fiberglass 2 kV minimum voltage rating
Conductor mounting hole: Number and Dimensions	Dependent on number of conductors to be attached Holes should be 11 mm (7/16 in.) on 19 mm (3/4 in.) or 24.5 mm (1 in.) centers to permit the convenient use of two-hole lugs Slotted hole patterns may be used if properly sized to minimum dimensions listed in this table
Method of attachment of grounding electrode conductor or bonding conductor	Exothermic welding Two-hole exothermic lug Listed two-hole irreversible compression lug Irreversible high-compression connection

5.6.1.2 Primary Bonding Bar Location

The Primary Bonding Bar (PBB) mounting location requirements are as follows:

- Where practicable, the PBB **shall** be located within the single-point entry window. See “Single-Point Grounding (Earthing) and the Single-Point Entry Window” on page 5-7.
- The PBB **shall** be installed as close as practicable to the electrical service entrance panel and **shall** be installed to maintain clearances required by applicable electrical codes (TIA-607-C, section 7.2.1).
- Where practicable, the PBB **shall** be located within 610 mm (24 in.) of the RF transmission line entry point into the facility.
- The PBB **shall** be installed below the RF transmission line entry point and the RF surge protective devices. This is to allow for a continuous downward discharge path.
- In buildings or shelters where RF transmission lines enter at floor level or through conduits within the floor, the PBB should be located on the wall or floor immediately adjacent to the RF transmission lines entry point.

- In buildings or shelters where RF transmission lines enter at ceiling level or through conduits within the ceiling, the PBB should be located immediately adjacent to the RF transmission lines entry point. See Figure 5-11 for an example.
- In all cases, the PBB **shall** be placed in a position that provides for the shortest and straightest downward routing of bonding conductors to the grounding electrode system.

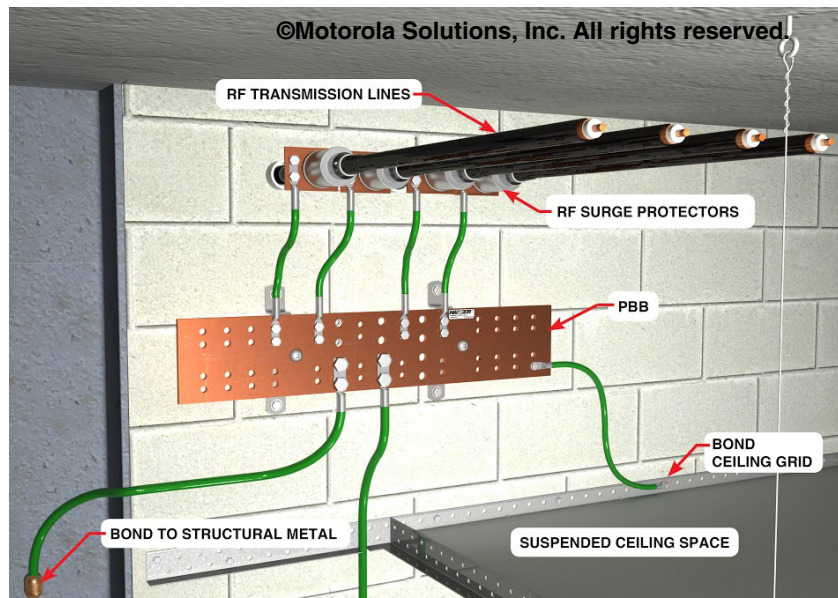

Figure 5-11 RF Transmission Lines Entry Entering Equipment Room Above Suspended Ceiling

5.6.1.3 Primary Bonding Bar Support

The Primary Bonding Bar (PBB) supporting requirements are as follows:

- The PBB **shall** be secured to the structure using brackets suitable for the application.
- The PBB **shall** be insulated from its support structure using listed insulators. See Table 5-1 and TIA-607-C for additional information.
- A minimum 51 mm (2 in.) separation from the supporting surface is recommended to allow access to the rear of the bus bar (TIA-607-C).

5.6.1.4 Primary Bonding Bar Grounding Electrode Conductor

The Primary Bonding Bar (PBB) grounding electrode conductor is the conductor that bonds the internal bonding system PBB to the electrical system ground and/or directly to the grounding (earthing) electrode system (common grounding electrode system at the site). In a dedicated communications shelter, the grounding electrode conductor typically bonds the PBB directly to the grounding electrode system. In a larger commercial building (such as a communications center), the grounding electrode conductor typically bonds the PBB to the electrical service equipment ground and/or directly to the grounding electrode system. See Figure 5-1, Figure 5-2, Figure 5-3 and Figure 5-4 for examples.

The grounding electrode conductor **shall** meet the following specifications:

- The PBB grounding electrode conductor **shall** meet the requirements of “Bonding and Grounding (Earthing) Conductors” on page 5-39.
- The PBB grounding electrode conductor **shall** be 35 mm² csa (#2 AWG) or larger (ATIS-0600334.2013).
 - If the PBB grounding electrode conductor is greater than 10 m (33 ft) in length, it **shall** be sized according to length as shown in Table 5-3.
 - In larger buildings that contain a bonding backbone, the PBB **shall** bond to the electrical service equipment (power) ground using a conductor of the same size or larger, as the bonding backbone conductor (TIA-607-C).

- If the building contains a DC power plant, the PBB **shall** bond to the electrical service equipment (power) ground as described in “DC Power Systems” on page 5-89 and associated subsections.
- In high lightning prone areas, it is recommended to use a larger conductor, such as 120 mm² csa (#4/0 AWG) (NWSM 30-4106 2014, section 2.6.7.2).
- The PBB grounding electrode conductor **shall** be free of splices (TIA-607-C).
 - **Exception:** Should a splice become necessary, splicing **shall** be permitted only by exothermic weld or listed irreversible compression-type connection (NFPA 70-2017, Article 250.64(C)).



IMPORTANT

Where structural metal is accessible and in the same room as the PBB, the PBB **shall** be bonded to structural metal using a conductor as described in this section (see TIA-607-C).

5.6.1.5 Primary Bonding Bar (PBB) Grounding Electrode Conductor Routing

In addition to the requirements described in “Bonding and Grounding (Earthing) Conductor Routing and Installation Requirements” on page 5-43, the PBB grounding electrode conductor **shall** meet the following routing requirements:

- The grounding electrode conductor **shall** be routed to the grounding electrode system with no sharp bends or narrow loops and with the shortest and straightest downward routing path as practicable.
- Where routing the grounding electrode conductor through a perimeter wall to the external grounding electrode system, the conductor should be routed through the wall in a flexible non-metallic conduit sleeve at a 45 degree angle towards the earth. See Figure 5-12 for an example.

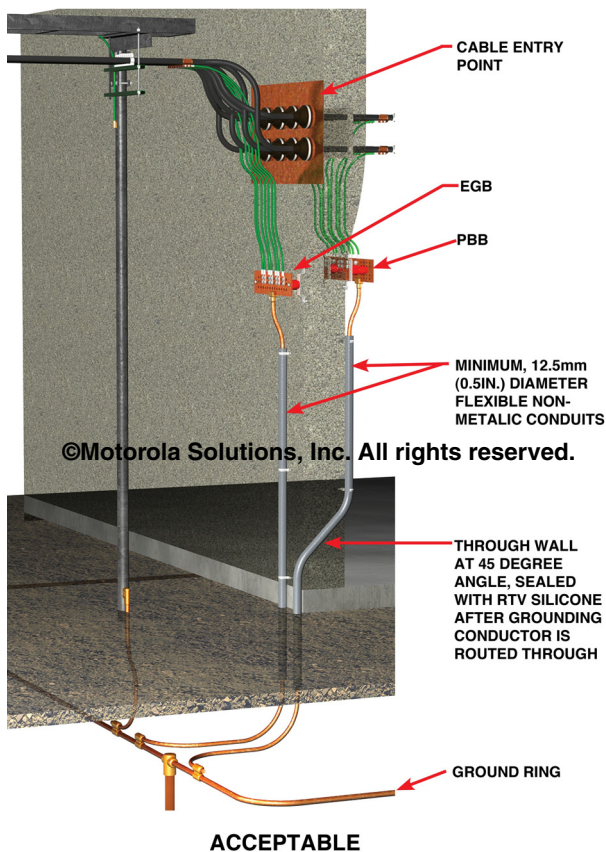

Figure 5-12 Routing and Protecting of PBB Grounding Electrode Conductor

5.6.1.6 Primary Bonding Bar Conductor Connection Methods

Bonding conductor and grounding electrode conductor connection to the Primary Bonding Bar (PBB) **shall** be made according to “Bonding to the Primary Bonding Bar, Secondary Bonding Bar and Rack Bonding Bar” on page 5-74 and “Connection to the Primary Bonding Bar” on page 5-75.

- The PBB grounding electrode conductor **shall** be bonded to the PBB by exothermic weld, listed irreversible compression two-hole lug, two-hole exothermic lug or irreversible high compression-type connection (ATIS-0600334.2013, ANSI/NECA/BICSI-607-2011 and TIA-607-C).
- The PBB grounding electrode conductor **shall** be bonded to the grounding electrode system using methods described in “Bonding to the External Grounding and Bonding System” on page 4-57.

5.6.1.7 Primary Bonding Bar Grounding Electrode Conductor Identification

The Primary Bonding Bar (PBB) grounding electrode conductor identification specifications are as follows:

- Where the grounding electrode conductor is insulated, the jacket **shall** be identified with a green coloring as described in “Bonding and Grounding (Earthing) Conductor General Specifications” on page 5-39.
- The grounding electrode conductor **shall** be labeled at the PBB (see TIA-607-C).
- Where the PBB grounding electrode conductor terminates in the electrical service panel (such as in a commercial building), the grounding electrode conductor **shall** also be labeled as close as practicable to its point of termination to the electrical service (power) ground (TIA-607-C).
- The labels **shall** be placed in readable locations and **shall** be of a nonmetallic material.
- See Figure 5-13 and TIA-607-C for labeling requirements.



Figure 5-13 PBB Grounding Electrode Conductor Identification

5.6.2 Integrated Panels and Cable Entry Ports

Integrated panel kits may be used in place of the Primary Bonding Bar (PBB). Specifications and installation requirements for integrated panel kits are as follows:

- Integrated panels **shall** be a factory assembly designed for the purpose of grounding.
- Integrated panels **shall** be listed by a Nationally Recognized Testing Laboratory (NRTL).
- Integrated panels **shall** be installed per the manufacturer's instructions.
- Integrated panel interconnecting devices (for example, brass rods) should be routed through the structure wall in rigid non-metallic conduits. The wall penetrations **shall** be sealed using appropriate weather proofing material.
- Integrated panels should be sized to accommodate future growth.
- See Figure 5-14 for an integrated panel kit example.



NOTE

Some integrated panel kits eliminate the need for a PBB grounding electrode conductor. The connection to earth is achieved via the feed-through mounting bolts and the External Ground Bus bar (EGB) grounding electrode conductor.

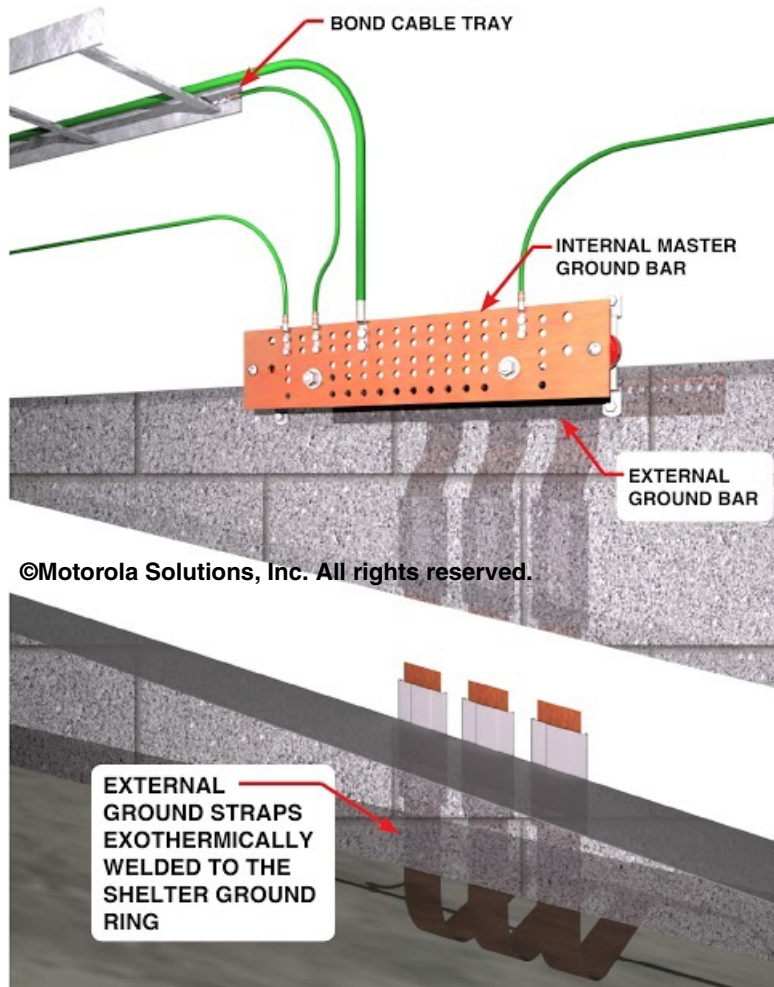

Figure 5-14 Integrated Panel Kit with Ground Straps

Integrated cable entry ports may be used in place of the PBB. Specifications and installation requirements for integrated cable entry ports are as follows:

- Integrated cable entry ports may be used in place of the PBB if they have adequate surface area for proper termination of the internal bonding conductors.
- Integrated cable entry ports **shall** be of solid copper construction and electrically continuous between the interior and exterior of the structure.
- Integrated cable entry ports **shall** be factory assembled and designed for the purpose of grounding.
- Integrated cable entry ports **shall** be installed per the manufacturer's instructions.
- Integrated cable entry ports should be sized to accommodate future growth.
- See Figure 5-15 for examples of cable entry ports.

**NOTE**

Some integrated cable entry ports eliminate the need for a PBB grounding electrode conductor. The connection to earth is achieved via the solid copper construction and the External Ground Bus bar (EGB) grounding electrode conductor.

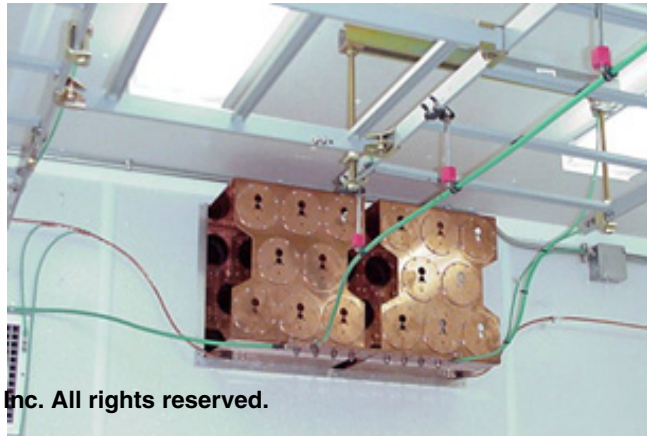

©Motorola Solutions, Inc. All rights reserved.

Figure 5-15 Examples of Integrated Cable Entry Ports

5.6.3 Sub System Ground Bus Bar or Secondary Bonding Bar

A Secondary Bonding Bar (SBB), previously referred to as a Sub System Ground Bus Bar (SSGB), is a bus bar used as a convenient extension of the Primary Bonding Bar (PBB) or Master Ground Bus Bar (MGB). In other standards, it may be referred to as a Floor Ground Bar (FGB), Telecommunications Grounding Bus bar (TGB) or Position Bonding Terminal (PBT) (see ATIS-0600313.2013, ATIS-0600333.2013, ATIS-0600321.2010 and TIA-607-C for additional information). More than one SBB may be installed in a building, shelter, room or area.

**NOTE**

Throughout this chapter the terms “Sub System Ground Bus Bar” (SSGB) and “Secondary Bonding Bar” (SBB) are used interchangeably. In an effort to better align with national and international standards, Secondary Bonding Bar (SBB) will be the preferred naming convention in this publication.

The purpose of an SBB is to provide a convenient internal bonding termination point for communications equipment, equipment bonding conductors, internal perimeter bonding bus conductors, surge protective devices or ancillary support equipment. An SBB may function as a single point bonding bar for a separate room of a building or shelter, as a common bonding bar for a communications cable entry port, in assemblies of communications equipment cabinets or at a group of network operator positions as referenced in this chapter.

See Figure 5-17, Figure 5-18, Figure 5-19 and Figure 5-20 for typical SBB installations.

**NOTE**

Not all communications sites will require the use of an SBB or SSGB.

**IMPORTANT**

Where an SBB is installed in a separate area of a building, or where an SBB must feed another SBB, the requirements of “Bonding Backbone and Bonding Backbone Conductor” on page 5-53 shall be followed.

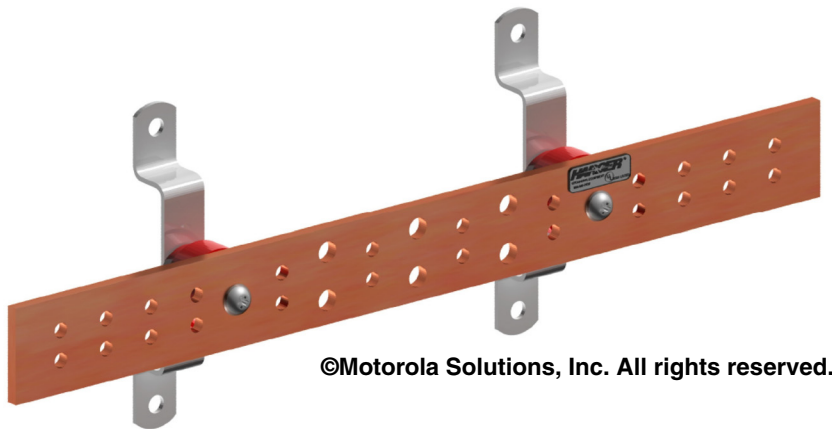

©Motorola Solutions, Inc. All rights reserved.

Figure 5-16 Typical Secondary Bonding Bar with Insulated Mounting Hardware



NOTE

In the example shown in Figure 5-17, the SBB in each equipment room can be considered a Primary Bonding Bar (PBB) for that room.

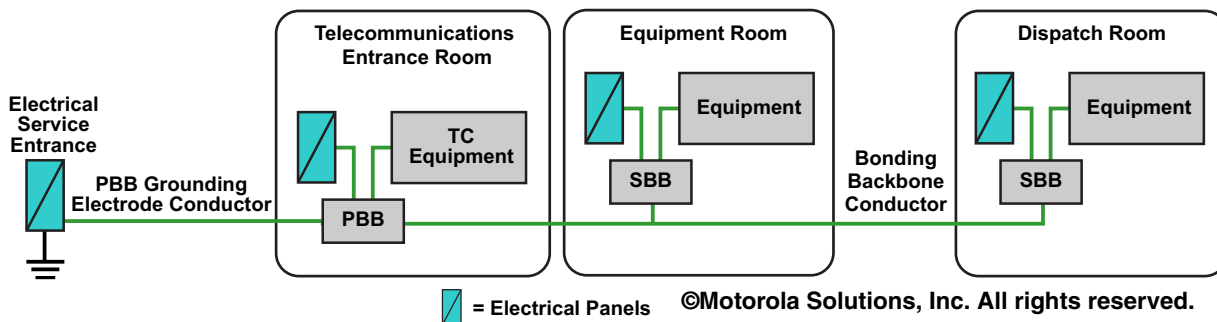

Figure 5-17 Example of Secondary Bonding Bar Configuration for a Commercial Building



IMPORTANT

An SBB shall not be extended to another building/shelter. In these cases a separate internal bonding/grounding system shall be installed in each building.



NOTE

In the example in Figure 5-18, the SBB in each dispatch position area can be considered a PBB for that area.



IMPORTANT

Where structural metal is accessible and in the same room as the SBB, the SBB shall be bonded to structural metal using a conductor as described in this section (see TIA-607-C).

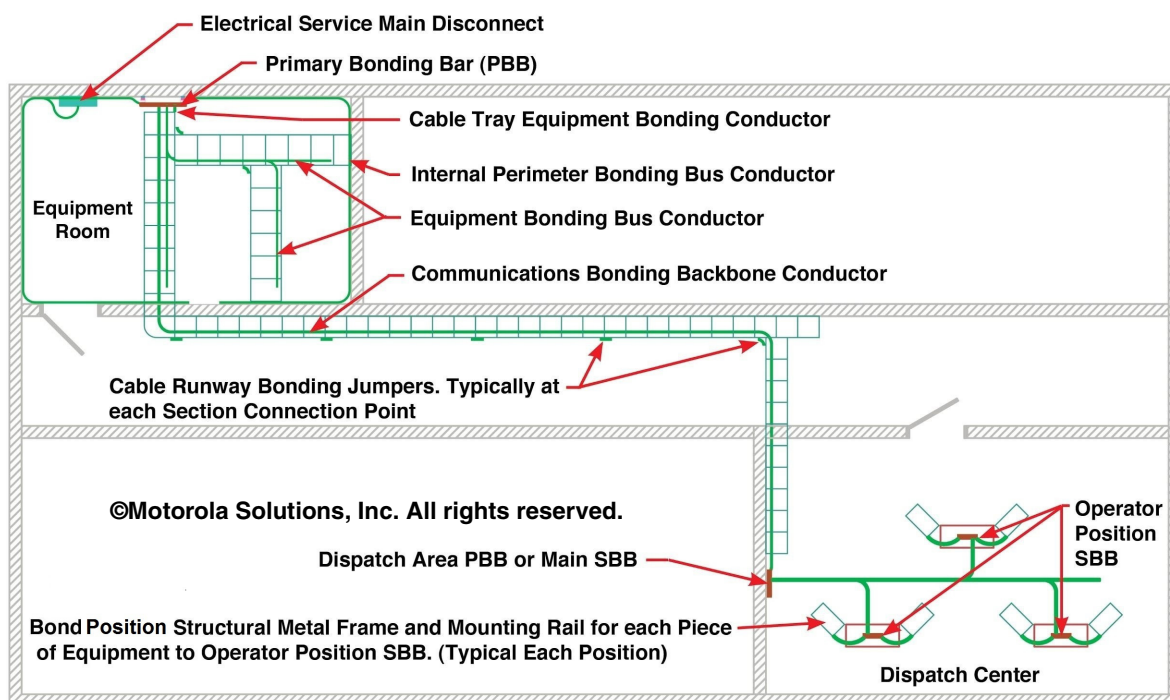

Figure 5-18 Example of a Main Secondary Bonding Bar Configuration for a Dispatch Center



NOTE

In the example in Figure 5-19, the SBB in each equipment room can be considered a PBB for that room.



NOTE

For multi-story or commercial buildings, structural metal may be the best available option to serve as the grounding electrode conductor.

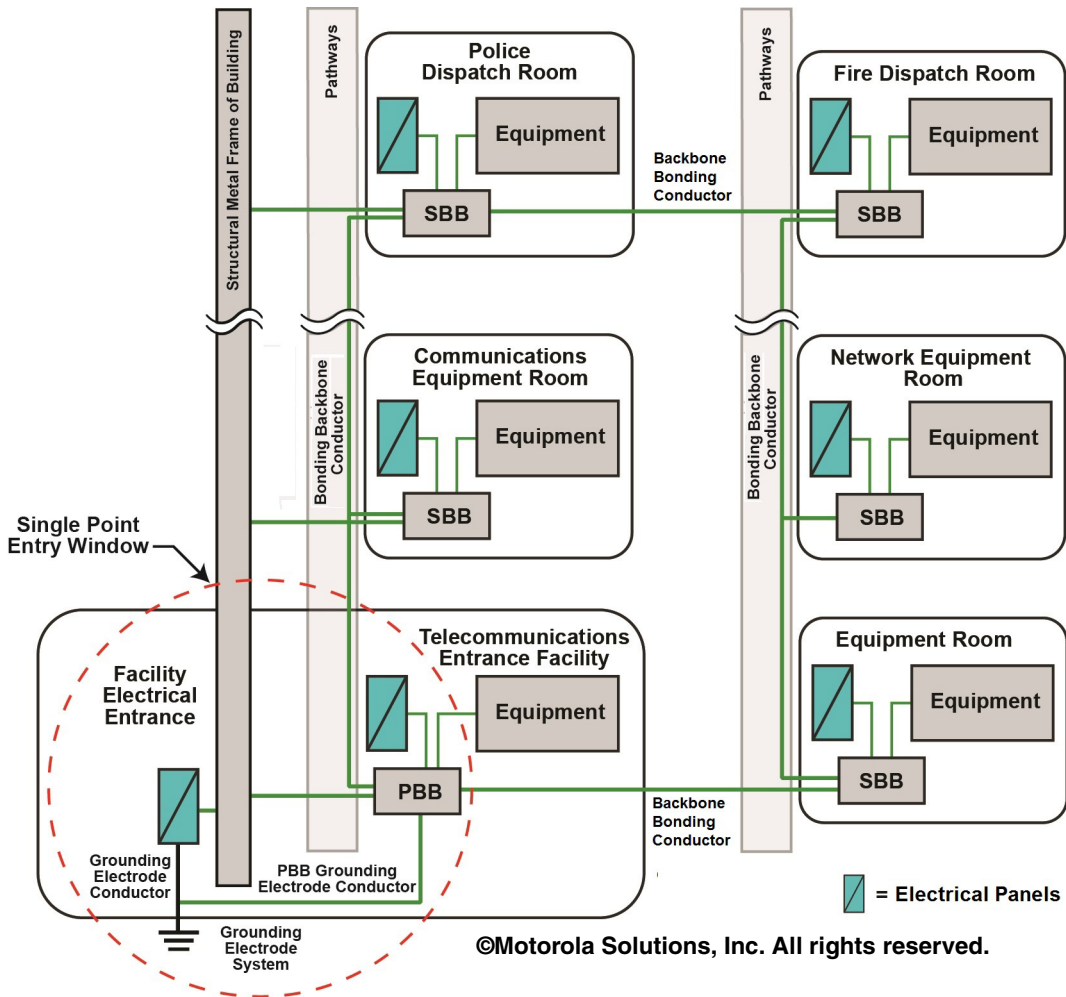

Figure 5-19 Example of Secondary Bonding Bar Configuration for Multi-Story Building

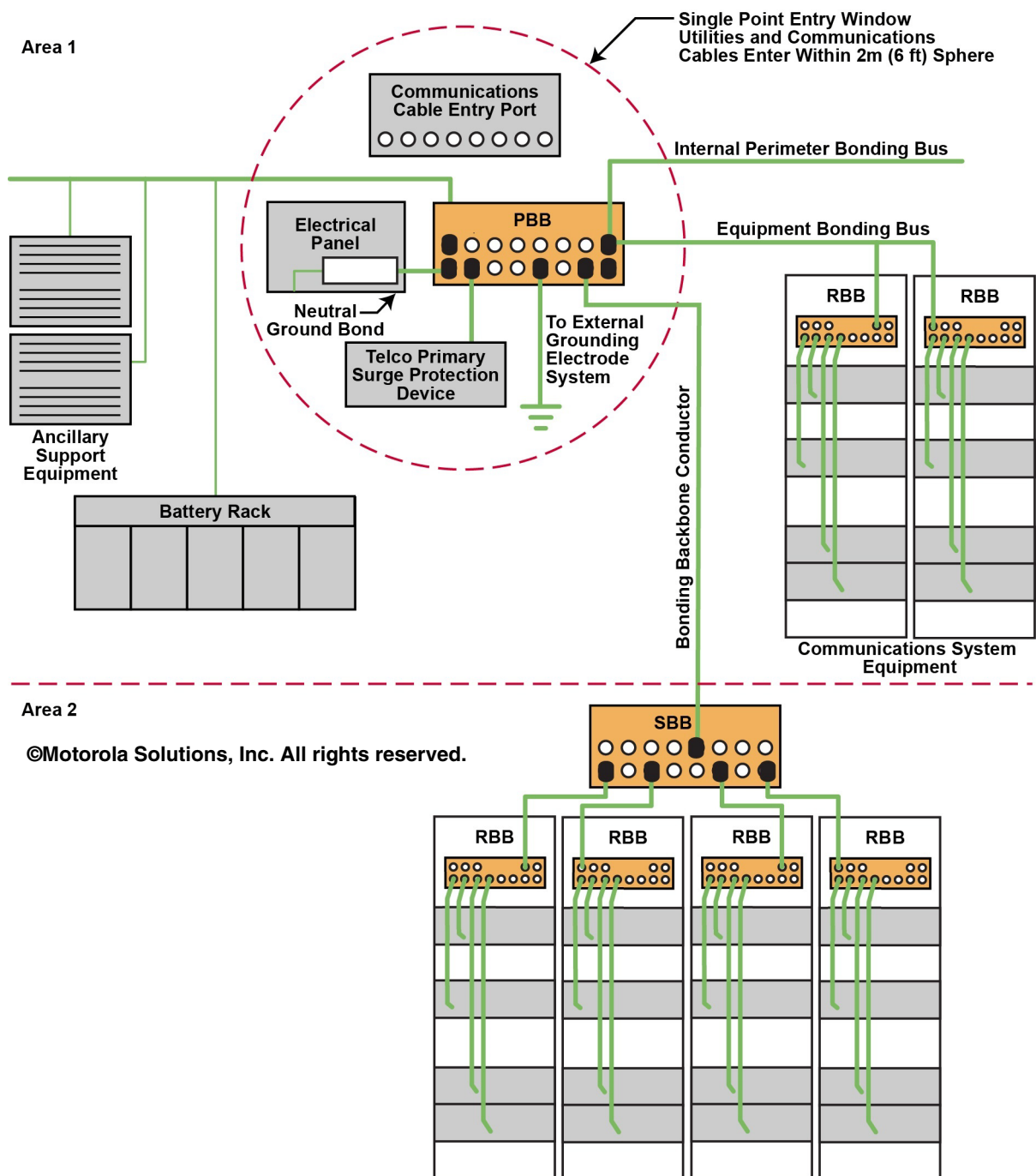

Figure 5-20 Typical Secondary Bonding Bar Configuration for Separate Equipment Area

5.6.3.1 Secondary Bonding Bar Specifications

Specifications for a Secondary Bonding Bar (SBB) are as follows:

- The SBB **shall** be constructed and minimally sized according to Table 5-2.
- Where the SBB serves at an entry point, the SBB **shall** be sized the same as a PBB.

- The SBB **shall** be designed for the purpose of grounding and **shall** be listed by a Nationally Recognized Testing Laboratory (NRTL) (see TIA-607-C).
- The SBB **shall** be sized according to the immediate application and consideration should be given to future growth of the site (TIA-607-C).
- See Table 5-2 for additional specifications and requirements.

Table 5-2 SECONDARY BONDING BAR SPECIFICATIONS

Item	Specification
Listing Requirement	Shall be listed by a nationally recognized testing laboratory (TIA-607-C).
Material	Bare, solid Alloy 110 (99.9%) copper bus bar or plate of one piece construction.
Minimum Dimensions (TIA-607-C)	Height: 50.8 mm (2 in.) Thickness: 6.35 mm (1/4 in.) Length: Variable to meet the application requirements and allow for future growth. 305 mm (12 in.) is recommended as the minimum length.
Mounting Brackets	Suitable for the application and should provide a minimum 50.8 mm (2 in.) separation from the supporting surface (TIA-607-C, section 7.3.1)
Insulators	Polyester fiberglass 2 kV minimum voltage rating
Conductor mounting holes	Dependent on number of conductors to be attached Holes should be 11 mm (7/16 in.) on 19 mm (3/4 in.) or 24.5 mm (1 in.) centers to permit the convenient use of two-hole lugs Slotted hole patterns may be used if properly sized to minimum dimensions listed in this table
Method of conductor attachment: SBB-to-PBB, SBB-to-Grounding Electrode Conductor or bonding conductor.	Exothermic welding Two-hole exothermic lug Listed two-hole irreversible compression lug Irreversible high-compression connection

**NOTE**

Where the SBB serves an entry point (such as a secondary cable entry port), the SBB **shall** be sized the same as a Primary Bonding Bar (see “Primary Bonding Bar Specifications” on page 5-12).

**IMPORTANT**

Only an SBB serving an entry point shall have a direct connection to earth using a grounding electrode conductor, in addition to the bonding conductor to the PBB.

5.6.3.2 Secondary Bonding Bar Location

The location and placement of a Secondary Bonding Bar (SBB) is site specific and may vary from site to site. The general location requirements and guidelines are as follows:

- The SBB **shall** be installed at a position that provides the shortest and straightest routing of bonding conductors to the Primary Bonding Bar (PBB).

- The SBB **shall** be placed at an accessible location where it is most convenient to terminate bonding conductors.
- Where installed at a network operator position, the SBB **shall** be placed at an accessible location that prevents tripping hazards and damage to the bonding conductors. See Figure 5-21 for an example.
- See Figure 5-17, Figure 5-18, Figure 5-19 and Figure 5-20 for SBB configuration examples.
- Where used as a single point bonding/grounding bus bar for a separate room or area, the SBB **shall** be installed as follows (TIA-607-C):
 - The SBB should be located within a single point entry window for the equipment room or area.
 - Where practicable, the SBB should be located near the electrical distribution panelboard that provides power to the equipment, and it **shall** be installed to maintain clearances required by applicable electrical codes.
 - The vertical placement of the SBB should be determined by the routing of bonding conductors (under a raised floor or in an overhead cable tray) and the routing of the SBB bonding conductor to the PBB.
- Where used as a common bonding bus bar for primary, secondary or RF surge protective devices, the SBB **shall** be placed within 610 mm (24 in.) of the communications cables entry point. See Figure 5-22 and Figure 5-23 for examples.

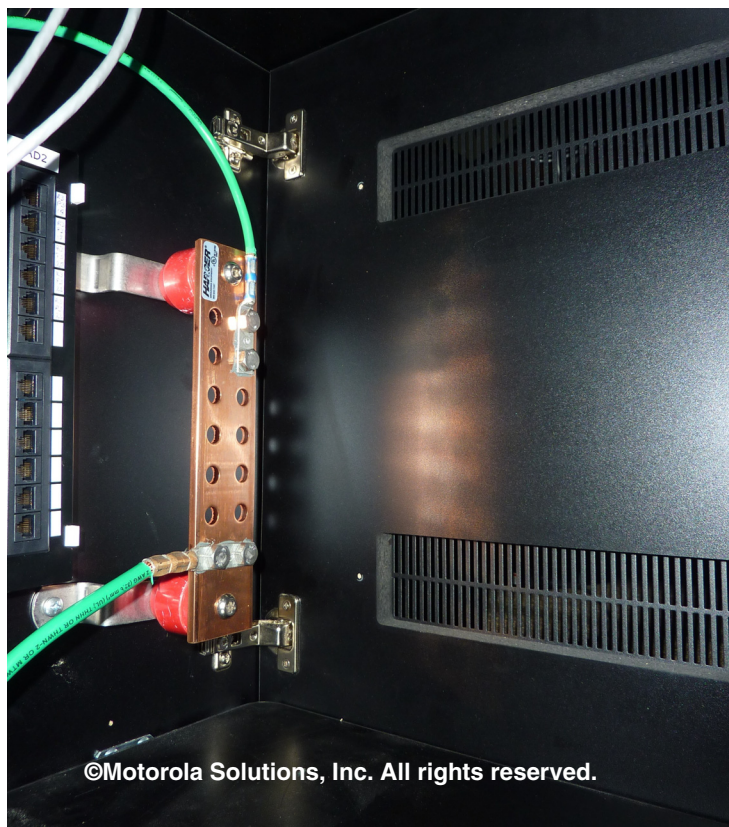

Figure 5-21 Example of a Secondary Bonding Bar at a Network Operator (Dispatch) Position



NOTE

Where an SBB serves a separate equipment room or area, it effectively becomes the PBB or Master Ground Bus Bar (MBG) for that area.

5.6.3.3 Secondary Bonding Bar Support

The Secondary Bonding Bar (SBB) supporting requirements are as follows:

- The SBB **shall** be secured to the structure using brackets suitable for the application.
- The SBB **shall** be insulated from its support structure using listed insulators. See Table 5-2 and TIA-607-C for additional information.
- A minimum 51 mm (2 in.) separation from the supporting surface is recommended to allow access to the rear of the bus bar. This is to allow room for securing the hardware, adding additional bonding conductors, and so on.
- An SBB may be supported from the ceiling or wall with rigid trapeze mounting structures. See Figure 5-22 and Figure 5-23 for examples.

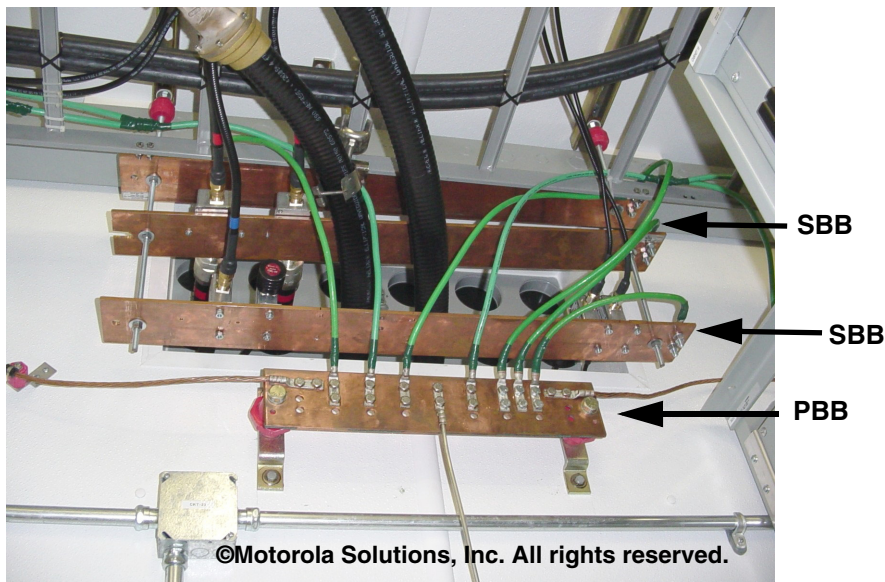

Figure 5-22 Ceiling Supported Secondary Bonding Bars at a Ceiling Level Communications Cable Entry



Figure 5-23 Wall Supported Secondary Bonding Bar at a Floor Level Communications Cable Entry Port

5.6.3.4 Secondary Bonding Bar Bonding Conductor

A Secondary Bonding Bar (SBB) bonding conductor is the conductor that bonds the SBB to the internal bonding and grounding system. Such bonds are to the following: Primary Bonding Bar (PBB), bonding backbone conductor, bonding bus conductor or bonding grid. The SBB bonding conductor **shall** meet the following requirements:

- The SBB bonding conductor **shall** meet the requirements of “Bonding and Grounding (Earthing) Conductors” on page 5-39 and all applicable subsections.
- The SBB bonding conductor **shall** be free of splices.
- The SBB bonding conductor **shall** be 35 mm² csa (#2 AWG) or larger and sized according to Table 5-3.
- Where an SBB bonds directly to the PBB, the SBB-to-PBB conductor **shall** be 35 mm² csa (#2 AWG) or larger and **shall** be sized according to Table 5-3.
- Where an SBB bonds directly to a bonding backbone conductor, the SBB-to-bonding backbone conductor **shall** be sized the same as the bonding backbone conductor.
- Where an SBB bonds to a bonding grid, the SBB-to-bonding grid conductor **shall** be 35 mm² csa (#2 AWG) or larger and sized according to Table 5-3.

5.6.3.5 Secondary Bonding Bar Conductor Connection Methods

Bonding conductor and grounding electrode conductor connection to the Secondary Bonding Bar (SBB) **shall** be made according to “Bonding to the Primary Bonding Bar, Secondary Bonding Bar and Rack Bonding Bar” on page 5-74.

- The SBB bonding conductor **shall** be bonded to the PBB by exothermic weld, listed irreversible compression two-hole lug, two-hole exothermic lug or irreversible high compression-type connection (ATIS-0600334.2013 and ANSI/NECA/BICSI-607-2011). Single-hole lugs are not permitted.
- The SBB grounding electrode conductor **shall** be bonded to the SBB by exothermic weld, listed irreversible compression two-hole lug, two-hole exothermic lug or irreversible high compression-type connection (ATIS-0600334.2013, ANSI/NECA/BICSI-607-2011 and TIA-607-C).
- The SBB grounding electrode conductor **shall** be bonded to the grounding electrode system using methods described in “Bonding to the External Grounding and Bonding System” on page 4-57.

5.6.3.6 Secondary Bonding Bar Conductor and Grounding Electrode Conductor Identification

The Secondary Bonding Bar (SBB) bonding conductor and grounding electrode conductor **shall** meet the following identification requirements:

- Where the conductors are insulated, the jacket **shall** be identified with a green coloring as described in “Bonding and Grounding (Earthing) Conductor General Specifications” on page 5-39.
- The SBB bonding conductor **shall** be clearly labeled at each termination location (TIA-607-C).
- The SBB grounding electrode conductor **shall** be clearly labeled at the SBB.
- The labels **shall** be placed in readable locations and **shall** be of a nonmetallic material.
- See Figure 5-24 and TIA-607-C for labeling requirements.



Figure 5-24 Secondary Bonding Bar Grounding Electrode Conductor Identification

5.6.3.7 Secondary Bonding Bar Serving an Entry Point

Although not recommended and not a good design practice, occasionally a communications site will contain a cable entry point that is not located within the single point entry window. This condition may exist where a secondary communications cable entry point is used, where the cable entry point is located away from the electrical service entry point or where the communications/electronic equipment is located in a multi-story or commercial building.



IMPORTANT

Cable entry points located more than 6.1 linear meters (20 linear ft) from the Primary Bonding Bar (PBB) grounding electrode conductor require an Entry Point SBB (see “Surge Protective Devices” on page 5-117 and applicable subsections).



NOTE

Where the SBB serves as an entry point, the SBB **shall** be sized the same as a PBB.

Secondary cable entry points **shall** be provided with an SBB (Entry Point SBB) for the purpose of grounding and bonding the communications cables that enter at this point. The Entry Point SBB **shall** be bonded to the PBB as described in this chapter using a 35 mm² csa (#2 AWG) or larger conductor. If the Entry Point SBB is located more than 6.1 linear meters (20 linear ft) from the PBB grounding electrode system, the Entry Point SBB **shall** contain a grounding electrode conductor that directly bonds to the grounding electrode system with the shortest and straightest route practicable (see NFPA 70-2017, Articles 800.100, 810.21, 820.100 and 830.100). The SBB grounding electrode conductor **shall** meet the same requirements as for a PBB grounding electrode conductor as described in “Master Ground (Earth) Bus Bar or Primary Bonding Bar” on page 5-10 and applicable subsections.

Where an SBB has a requirement for a grounding electrode conductor, the conductor **shall** be routed to the grounding electrode system as follows:

- The SBB grounding electrode conductor **shall** route directly to the grounding electrode system with the shortest and straightest route as practicable (NFPA 70-2017, Articles 800.100, 810.21, 820.100 and 830.100).
- The SBB grounding electrode conductor **shall** be free of splices (TIA-607-C).
 - **Exception:** Should a splice become necessary, splicing **shall** be permitted only by exothermic weld or listed irreversible compression-type connection (NFPA 70-2017, Article 250.64(C)).
- The PBB grounding electrode conductor **shall** be bonded to the PBB by exothermic weld, listed irreversible compression two-hole lug, two-hole exothermic lug or irreversible high compression-type connection (ATIS-0600334.2013 and ANSI/NECA/BICSI-607-2011). Single-hole lugs are not permitted.
- If the SBB grounding electrode conductor has to route through a perimeter wall to the external grounding electrode system, it **shall** follow requirements described in “Primary Bonding Bar (PBB) Grounding Electrode Conductor Routing” on page 5-14.
- Where it is not practicable to bond the SBB to the external grounding electrode system, the SBB grounding electrode conductor **shall** route to the nearest accessible extension of the common grounding electrode system at the site (for example, effectively bonded structural metal or accessible rebar of the Ufer ground). See Figure 5-25 for an example.
- See Figure 5-26 for an example of a shelter secondary cable entry point SBB.



IMPORTANT

Entry points at multiple locations should be avoided where practicable.



NOTE

All conductor sizes given in Figure 5-26 represent the minimum size.

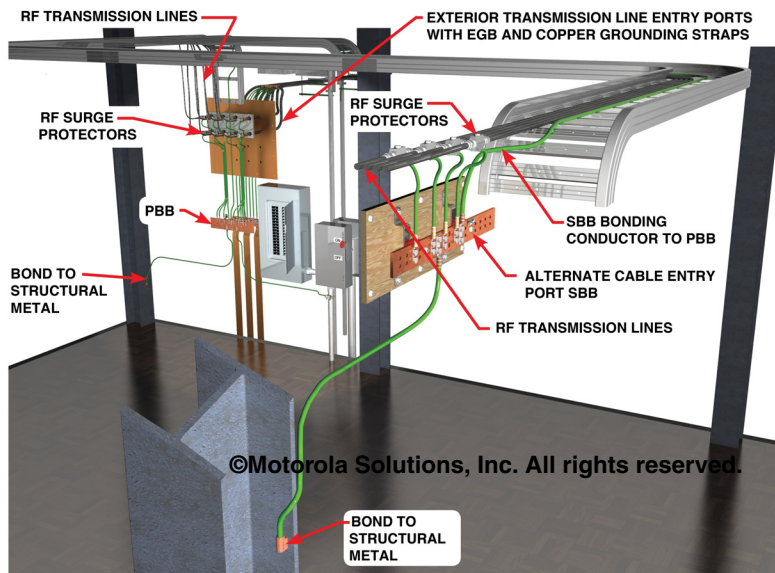

Figure 5-25 Entry Point SBB with Grounding Electrode Conductor at Alternate Entry

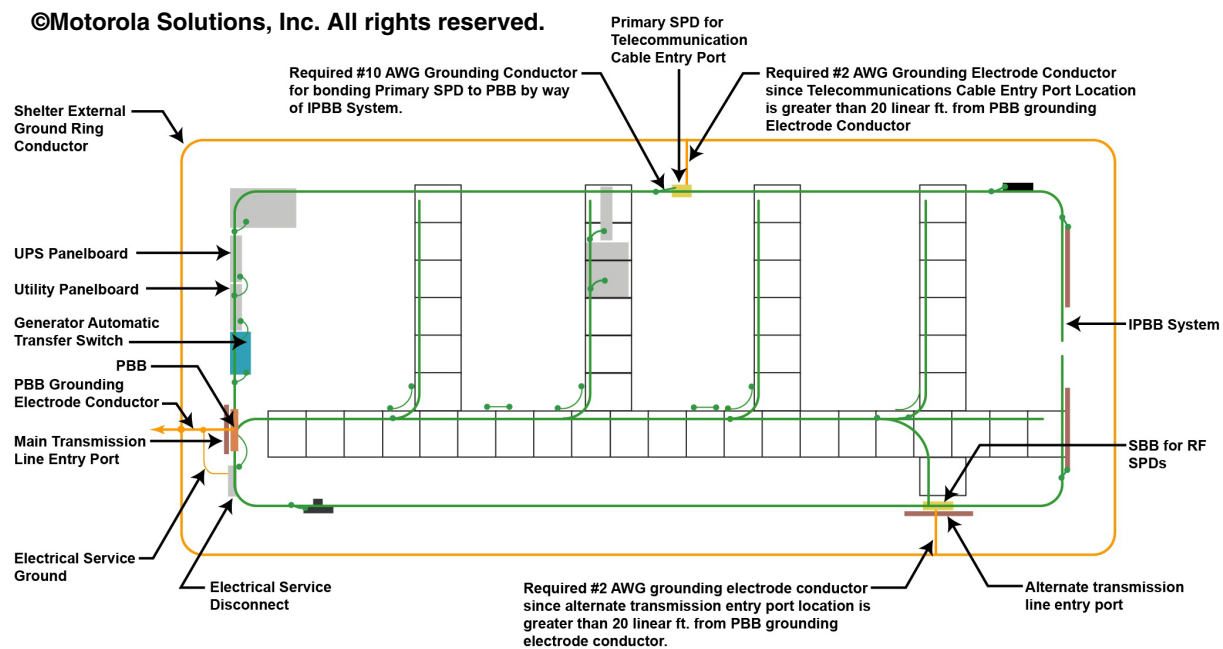

Figure 5-26 Secondary Communications Cable Entry Points at a Shelter

5.6.4 Rack Ground Bus Bar or Rack Bonding Bar

A Rack Bonding Bar (RBB), formerly referred to as a Rack Ground Bus bar (RGB), is a bus bar bonding termination point for equipment in a cabinet or rack. In other standards, it may be referred to as a Rack Grounding Busbar (RGB) or a Single Point Ground Bus bar (SPGB) (see ANSI/NECA/BICSI-607-2011 and FAA-STD-019e for additional information).

The purpose of an RBB is to provide a convenient bonding termination point for individual pieces of equipment and/or secondary surge protective devices installed within that cabinet or rack. The RBB may be installed vertically or horizontally. The bonding conductor for the cabinet or rack supporting framework may also terminate on the RBB. More than one RBB may be installed within a cabinet or rack, provided that both RBBs are bonded to the equipment bonding bus conductor with separate bonding conductors (see “Rack Bonding Bar Bonding Conductor” on page 5-31). See Figure 5-27 for an example.

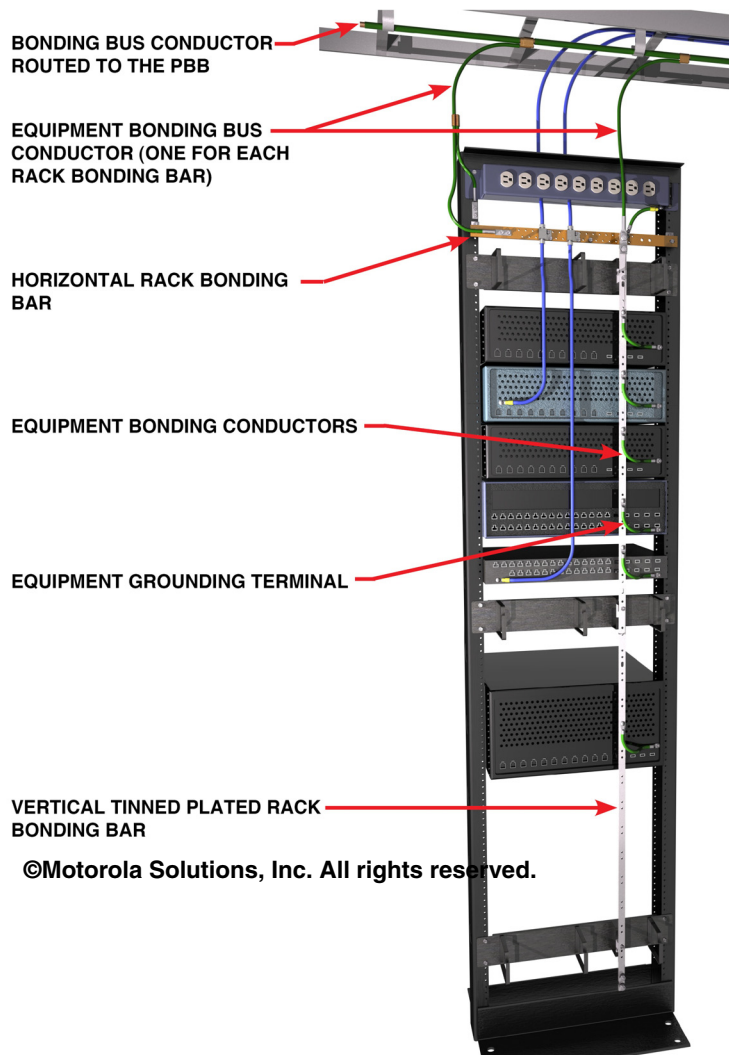

Figure 5-27 Equipment Rack with Multiple Rack Bonding Bars



IMPORTANT

One RBB shall not be bonded to another RBB, thus establishing a daisy chain bonding connection. Each RBB must bond directly to an equipment bonding bus conductor.

5.6.4.1 Rack Bonding Bar Specifications

Specifications for a Rack Bonding Bar (RBB) are as follows:

- The RBB **shall** be designed by the manufacturer for the purpose of electrical bonding.
- The RBB **shall** be a constructed from solid copper, tin-plated copper or copper alloy.

- The RBB **shall** be listed by a Nationally Recognized Testing Laboratory (NRTL).
- It is recommended that the bus bar be electrotin-plated to prevent dissimilar metal reactions.
- The RBB **shall** be sized no less than 4.76 mm (3/16 inch) in thickness and 12.7 mm (0.5 in.) in width, and its length **shall** be sized appropriately for the application.
- The bus bar **shall** have a suitable number of predrilled holes to accommodate the required number of equipment bonding conductors.
- The bus bar's predrilled holes may be tapped to provide for the use of machine screw-type fasteners.
- The bus bar **shall** have at least one set of pre-drilled holes or threaded posts located at one end of the bus bar to accommodate a standard two-hole lug for the RBB bonding conductor.

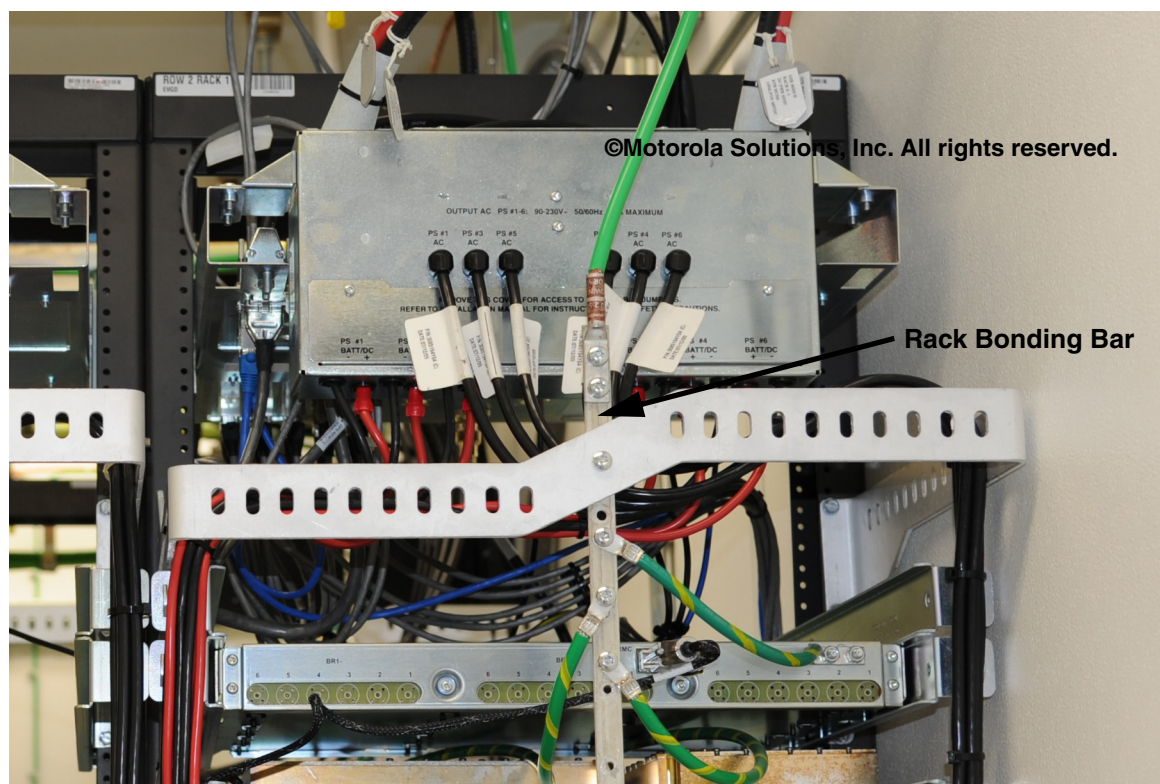

Figure 5-28 Example of Rack Bonding Bar

5.6.4.2 Rack Bonding Bar Location

Location and placement of a Rack Bonding Bar (RBB) are as follows:

- The RBB **shall** be placed at an accessible location where it is most convenient to terminate communications equipment or secondary Surge Protective Devices (SPD) with the shortest lengths of bonding conductors as practicable.
- The RBB may be placed horizontally between the equipment vertical support rails, at the top or bottom of the cabinet or rack, or attached to the vertical support rail with standoffs as described herein.
- The RBB may be supported vertically between horizontally positioned cable management rails. See Figure 5-29 for examples of RBB placement.
- Vertical placement of a horizontally mounted RBB and/or the RBB bonding conductor connection point **shall** be determined by the routing of the RBB bonding conductor to the internal bonding and grounding system infrastructure (for example, bonding bus conductor, SBB or PBB). Vertical placement should be determined by the location of the bonding and grounding infrastructure (for example, under a raised floor or in an overhead cable tray).

- The RBB **shall** be placed in a position that provides the shortest and straightest routing of the RBB bonding conductor to the internal bonding and grounding system infrastructure (for example, bonding bus conductor, SBB or PBB).

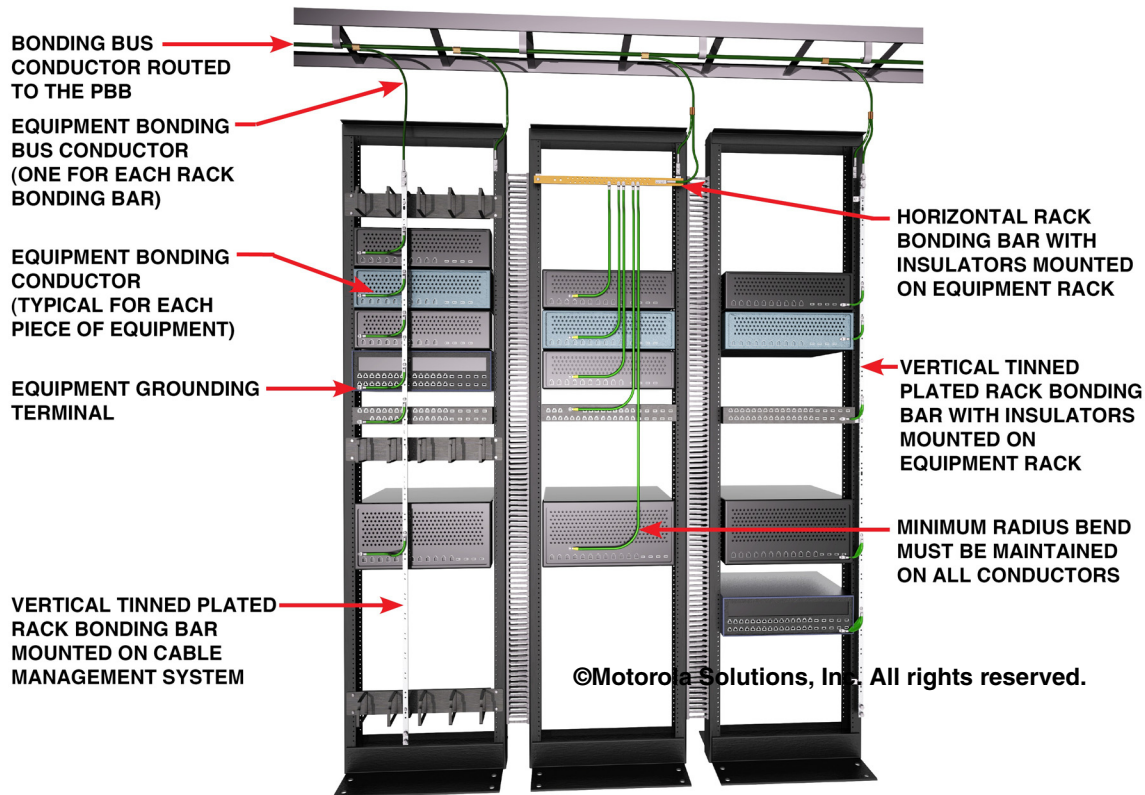

Figure 5-29 Rack Bonding Bar Mounting Configurations

5.6.4.3 Rack Bonding Bar Support

The Rack Bonding Bar (RBB) supporting requirements are as follows:

- A bare copper or copper alloy RBB **shall** be securely supported with suitable standoff hardware to maintain adequate separation between dissimilar metals and to facilitate conductor attachment. The use of insulators may be suitable for this purpose.
- An RBB may be attached directly to the cabinet or rack framework if the RBB is tin-plated. See Figure 5-30.
- If the RBB is mounted directly to the cabinet or rack framework, it **shall** allow for adequate spacing of bonding conductors. See Figure 5-30 for an example.

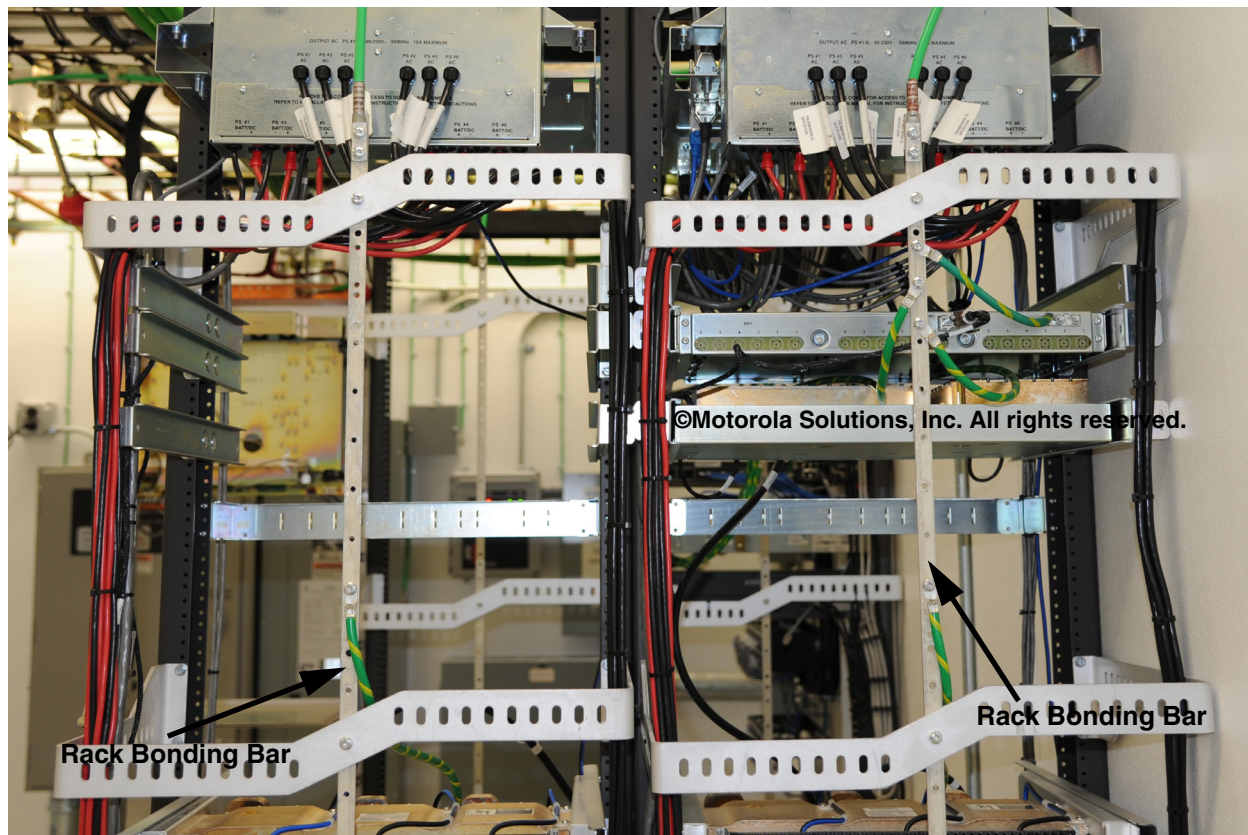

Figure 5-30 Example of Rack Bonding Bar Mounted to Cable Management System

5.6.4.4 Rack Bonding Bar Bonding Conductor

A Rack Bonding Bar (RBB) bonding conductor is the conductor that bonds the RBB to the internal bonding and grounding system infrastructure (for example, bonding bus conductor, SBB or PBB). In addition to the requirements described in “Bonding and Grounding (Earthing) Conductors” on page 5-39, the RBB bonding conductor **shall** meet the following specifications:

- The RBB bonding conductor **shall** be stranded copper unless otherwise specified in this chapter (TIA-607-C).
- The RBB bonding conductor **shall** be 35 mm² csa (#2 AWG) or larger.
- The RBB bonding conductor **shall** be green-jacketed as described in “Bonding and Grounding (Earthing) Conductors” on page 5-39.
- The RBB bonding conductor should be free of splices.



IMPORTANT

See “DC Powered Equipment Installed in Rack” on page 5-95 for RBB bonding conductor sizing where the RBB supports DC powered equipment.

5.6.4.5 Rack Bonding Bar Bonding Conductor Routing

In addition to the requirements described in “Bonding and Grounding (Earthing) Conductor Routing and Installation Requirements” on page 5-43, a Rack Bonding Bar (RBB) bonding conductor **shall** be routed towards the internal bonding and grounding system infrastructure (for example, bonding bus conductor, SBB or PBB) with no sharp bends or narrow loops and with the shortest and straightest routing path practicable.

5.6.4.6 Rack Bonding Bar Bonding Conductor Connection Methods

Bonding conductor connection to the RBB **shall** be made using a two-hole lug according to “Bonding to the Primary Bonding Bar, Secondary Bonding Bar and Rack Bonding Bar” on page 5-74 and “Connection to the Rack Bonding Bar” on page 5-75.

5.6.5 Network-Equipment Bonding Bar

A Network-Equipment Bonding Bar (NBB) is a bonding bar termination point for network equipment in a cabinet or rack. The purpose of an NBB is to provide a convenient bonding termination point for two or more similar pieces of network equipment installed adjacent to one another (horizontally or vertically) within the same cabinet or rack. See Figure 5-31 for an example.

Network equipment that bonds to an NBB **shall** be limited to switches, routers, patch panels or other types of low-powered or unpowered network equipment installed within the same cabinet or rack. More than one NBB may be installed within the same cabinet or rack, provided that each NBB is bonded to the Rack Bonding Bar (RBB) or bonding bus conductor with a separate bonding conductor. See Figure 5-32 for an example of a rack installation with two Network-Equipment Bonding Bars (NBB) bonded to an RBB.

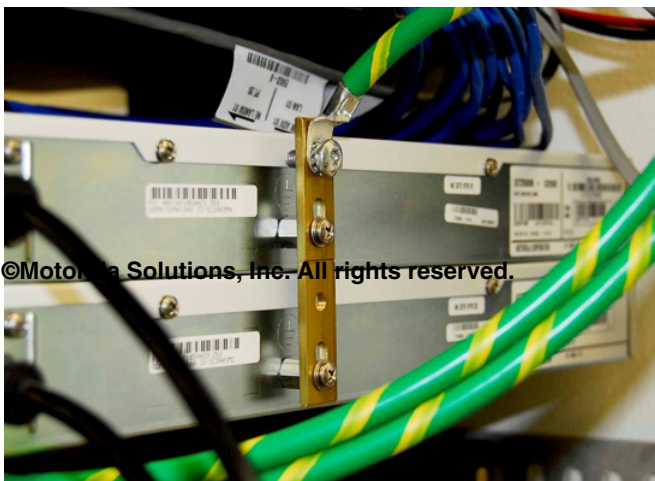

Figure 5-31 Example of Network-Equipment Bonding Bar

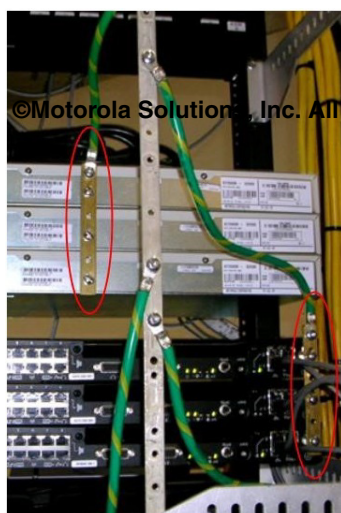

Figure 5-32 Rack with Two Network-Equipment Bonding Bars

**IMPORTANT**

Radio transceivers and other high-power equipment shall not be bonded to an NBB.

5.6.5.1 Network-Equipment Bonding Bar Specifications

Specifications for a Network-Equipment Bonding Bar (NBB) are as follows:

- The NBB **shall** be designed by the manufacturer for the purpose of electrical bonding.
- The NBB **shall** be made of solid copper, tinned copper or copper alloy.
- The NBB **shall** be sized no less than 3.175 mm (1/8 in.) in thickness and 15.875 mm (5/8 in.) in width.
- The NBB length **shall** be sized appropriately for the application.
- The NBB **shall** have a suitable number of predrilled holes to accommodate the required number of equipment chassis bonding connections.
- The NBB should be listed by a Nationally Recognized Testing Laboratory (NRTL).
- The NBB may have scored and detachable sections for sizing the bonding bar to length.

5.6.5.2 Network-Equipment Bonding Bar Location

Location of a Network-Equipment Bonding Bar (NBB) is as follows:

- An NBB **shall** only be placed within an equipment cabinet or rack.
- The NBB is typically mounted vertically between two or more pieces of equipment installed one above the other or horizontally between two or more pieces of equipment installed side-by-side. See Figure 5-33 for examples of typical NBB mounting locations.

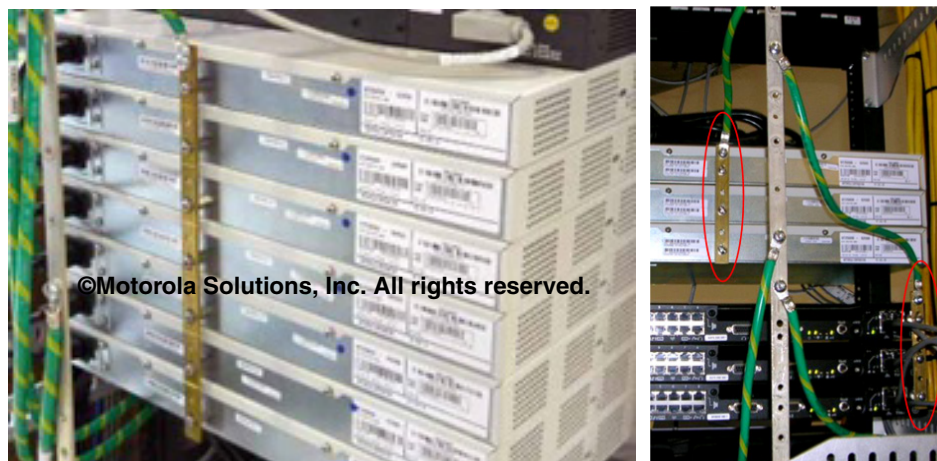

Figure 5-33 Typical Network-Equipment Bonding Bar Mounting Locations

5.6.5.3 Network-Equipment Bonding Bar Support and Bonding to Equipment

The Network-Equipment Bonding Bar (NBB) supporting requirements are as follows:

- The NBB **shall** be attached directly to the equipment chassis with approved hardware as described in this chapter.
- The NBB **shall** be attached to a manufacturer provided grounding post or an equipment chassis threaded hole using appropriate hardware.

- The NBB **shall** be attached to each equipment chassis with suitable stainless steel hardware. Stainless steel hardware is required to prevent issues caused by dissimilar metal reactions.
- If the equipment chassis grounding post is made of a material that is incompatible with copper (for example, zinc plated), a tin-plated bonding bar **shall** be used.
- The equipment chassis **shall** bond to the NBB with stainless steel machine screw-type fasteners or nuts as follows:
 - The NBB **shall** be secured to the equipment chassis tapped hole with machine screw-type fastener as shown in Figure 5-34 and Figure 5-35.
 - The NBB **shall** be secured to the equipment chassis threaded grounding post with nut as shown in Figure 5-34 and Figure 5-35.
 - The fasteners **shall** be equipped with lock washers and flat washers as shown in Figure 5-34.
 - Where a fastener is subjected to thermal cycling (for example, equipment installed in a non-climate-controlled cabinet), the lock washer should be replaced with a flat washer and a Belleville washer as shown in Figure 5-35. (ANSI/NECA/BICSI-607-2011).

**IMPORTANT**

Individual pieces of equipment shall not be attached to an NBB with a bonding conductor. An NBB shall only be used for bonding equipment that allows for a direct connection to the NBB. See Figure 5-34 and Figure 5-35.

5.6.5.4 Network-Equipment Bonding Bar Bonding Conductor

The Network-Equipment Bonding Bar (NBB) bonding conductor is the conductor that bonds the NBB to an RBB or equipment bonding bus conductor. In addition to the requirements described in “Bonding and Grounding (Earthing) Conductors” on page 5-39, the NBB bonding conductor **shall** meet the following specifications:

- The NBB bonding conductor **shall** be 16 mm² csa (#6 AWG) or larger.
- The NBB bonding conductor **shall** be sized according to Table 5-3.

5.6.5.5 Network-Equipment Bonding Bar Bonding Conductor Routing

In addition to the requirements described in “Bonding and Grounding (Earthing) Conductor Routing and Installation Requirements” on page 5-43, a Network-Equipment Bonding Bar (NBB) bonding conductor **shall** be routed towards the PBB as follows:

- The NBB bonding conductor **shall** route towards the PBB bonding and grounding system in a direct manner with no sharp bends or loops as described in this chapter. See routing and attachment of bonding conductor in Figure 5-36.
- Where practicable, the bonding conductor **shall** be attached to the end of the bonding bar to ensure all network equipment chassis have a direct sweeping flow path towards the PBB.
- If equipment is positioned at the top of the cabinet or rack and proper conductor routing to the RBB cannot be achieved, the NBB bonding conductor **shall** bond to the RBB bonding conductor so as to provide proper routing toward the PBB. See Figure 5-36.
- If an NBB is installed within a cabinet or rack without an RBB, the NBB bonding conductor **shall** be bonded to the cabinet or rack equipment bonding bus conductor.

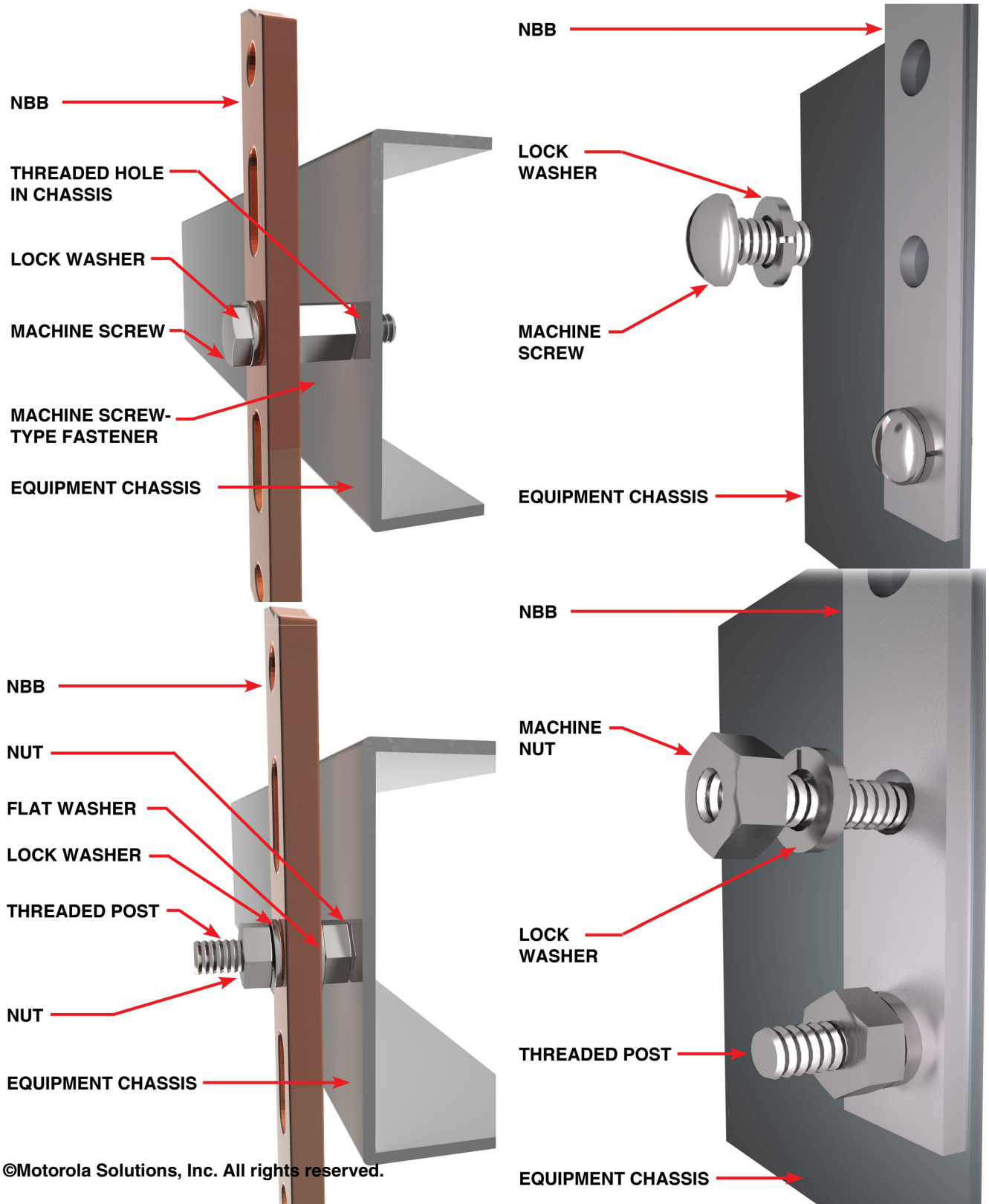

Figure 5-34 Examples of Bonding a Network-Equipment Bonding Bar to an Equipment Chassis with Lock Washers

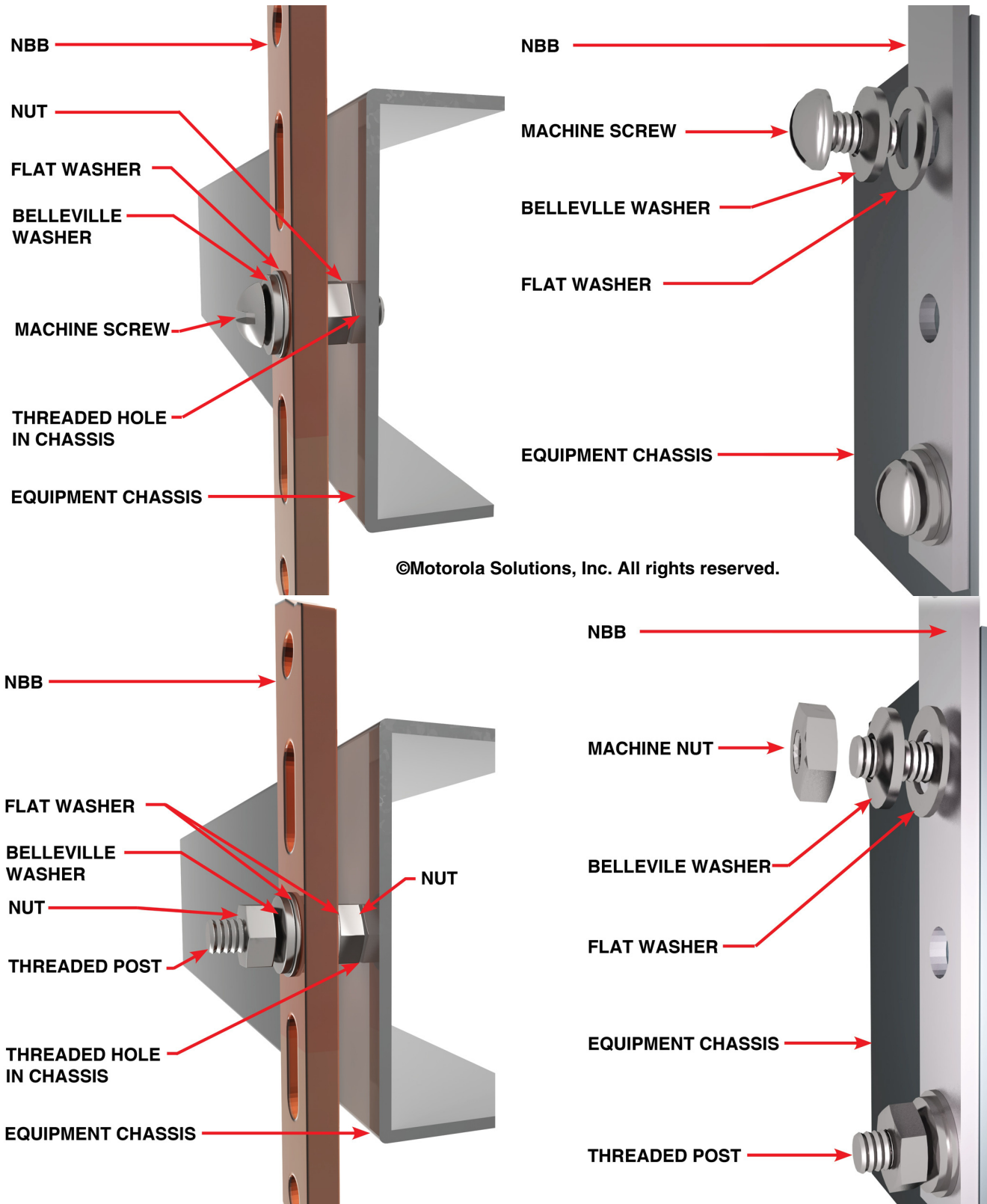

Figure 5-35 Examples of Bonding a Network-Event Bonding Bar to an Equipment Chassis with Belleville Washers

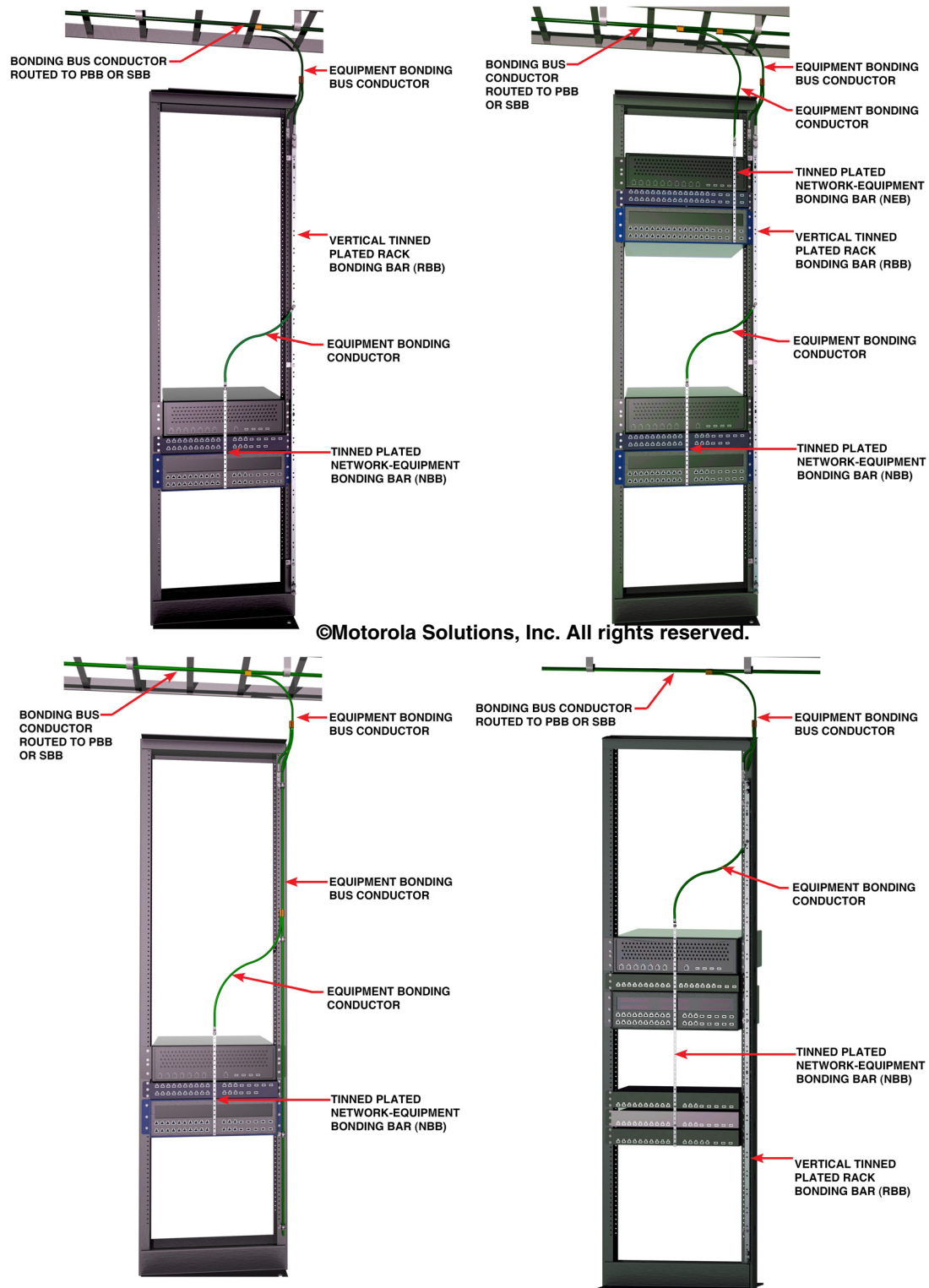

Figure 5-36 Acceptable Routing and Attachment of Network-Equipment Bonding Bar Bonding Conductor

5.6.5.6 Network-Equipment Bonding Bar Bonding Conductor Connection Methods

In addition to the requirements described in “Connection Methods for Internal Bonding and Grounding (Earthing) System” on page 5-64, a Network-Equipment Bonding Bar (NBB) bonding conductor **shall** meet the following bonding requirements:

- The NBB bonding conductor **shall** bond to the NBB and the RBB with listed irreversible compression lugs (single-hole or two hole) and stainless steel securing hardware (ANSI/NECA/BICSI-607-2011).
- Where the NBB bonding conductor cannot be attached to the RBB due to conductor routing restrictions, the conductor **shall** attach to a bonding bus conductor by following the requirements described in “Bonding to Bonding Bus Conductors” on page 5-77.



IMPORTANT

One NBB shall not be bonded to another NBB, thus establishing a daisy chain bonding connection. See Figure 5-37 for an example.

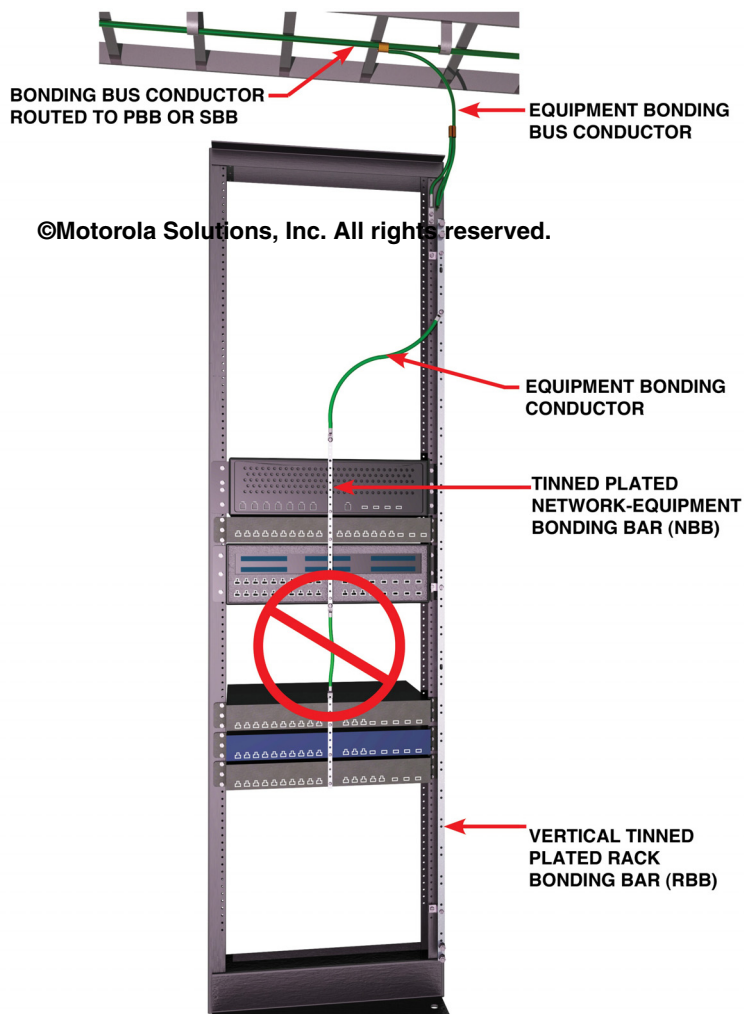

Figure 5-37 Non-acceptable Daisy Chain Bonding Connection

5.6.6 Bonding and Grounding (Earthing) Conductors

Proper equipment bonding and grounding helps prevent a difference of electrical potential between system components and/or metallic objects, thereby mitigating the risk of injury to personnel, system failure and damage to equipment.

Bonding and grounding conductors are the electrical conductors used to bond communications systems equipment and ancillary support apparatus to the site Primary Bonding Bar (PBB) and the grounding electrode system, forming an electrically conductive path.

The requirements in the following subsections **shall** apply to all interior bonding and grounding conductors, unless otherwise specified or amended.

5.6.6.1 Bonding and Grounding (Earthing) Conductor General Specifications

Conductor general specification requirements are as follows:

- Interior bonding and grounding conductors **shall** be stranded copper unless otherwise specified within this chapter (ANSI/NECA/BICSI-607-2011 and ATIS-0600334-2013).
- The grounding electrode conductor for a Primary Bonding Bar (PBB) or Secondary Bonding Bar (SBB) at an alternate cable entry point may be solid copper.
- Interior bonding and grounding conductors **shall** be jacketed unless otherwise specified within this chapter (ANSI/NECA/BICSI-607-2011 and ATIS-0600334-2013).
- The conductor insulating jacket **shall** be green, green with a yellow stripe, or properly marked with a distinctive green coloring, green tape or green adhesive label at the termination locations (NFPA 70-2017, Article 250.119, TIA-607-C and ANSI/NECA/BICSI-607-2011).
- Bonding conductors **shall** be listed for the application (TIA-607-C).



NOTE

Requirements for jacketing **shall not** apply to conductors of a Bonding Grid. See “Supplementary Bonding Network or Bonding Grid” on page 5-59.



IMPORTANT

Flat braided conductors shall not be used at any location as they can become a source of RF noise.

5.6.6.2 Bonding and Grounding (Earthing) Conductor Length and Gauge Requirements

Conductor length and gauge requirements are as follows:

- Bonding and grounding conductors **shall** be no longer than required to achieve the intended purpose (ANSI/NECA/BICSI-607-2011).
- Bonding conductors **shall not** decrease in size as the bonding path moves closer to the Primary Bonding Bar (PBB) (TIA-607-C, section 6.3.1).
- Conductor gauge requirements are specified in the appropriate sections of this chapter. In general, the following are required:
 - Bus conductors greater than 10 meters in length (33 ft) **shall** be increased in size according to Table 5-3.
 - Bus conductors (that is, conductors used to bond multiple items) **shall** be 35 mm² csa (#2 AWG) or larger.
 - Conductors bonding single items **shall** be 16 mm² csa (#6 AWG) or larger. Some exceptions to this requirement are found in the following sections:
 - “Bonding and Grounding (Earthing) for Dispatch Centers and Network Operator Positions” on page 5-133
 - “Primary Surge Protective Devices” on page 5-120

- “Secondary Surge Protective Devices” on page 5-120
- Bonding and grounding conductors as part of the bonding system infrastructure (for example, grounding electrode conductor, PBB-to-SBB conductor, bonding backbone conductors and bonding bus conductors) **shall** meet the size requirements shown in Table 5-3, unless otherwise specified (TIA-607-C).



IMPORTANT

Bonding conductors shall not decrease in size as the bonding path moves closer to the Primary Bonding Bar (PBB) (TIA-607-C, section 6.3.1).



NOTE

Improved bonding performance at high frequencies can be achieved by utilizing structural metal in place of or in addition to a bonding/grounding conductor as sized in Table 5-3.

Table 5-3 BONDING AND GROUNDING INFRASTRUCTURE CONDUCTOR SIZE REQUIREMENTS

Conductor Linear Length	Conductor Size		International Available Conductor Size
less than 4 m (13 ft)	13.30 mm ² csa	6 AWG	16 mm ²
4 to 6 m (14 to 20 ft)	21.15 mm ² csa	4 AWG	25 mm ²
6 to 8 m (21 to 26 ft)	26.67 mm ² csa	3 AWG	-
8 to 10 m (27 to 33 ft)	33.62 mm ² csa	2 AWG	35 mm ²
10 to 13 m (34 to 41 ft)	42.41 mm ² csa	1 AWG	-
13 to 16 m (42 to 52 ft)	53.49 mm ² csa	1/0 AWG	50 mm ²
16 to 20 m (53 to 66 ft)	67.43 mm ² csa	2/0 AWG	70 mm ²
20 to 26 m (67 to 84 ft)	85.01 mm ² csa	3/0 AWG	95 mm ²
26 to 32 m (85 to 105 ft)	107.26 mm ² csa	4/0 AWG	120 mm ²
32 to 38 m (106 to 125 ft)	126.70 mm ² csa	250 kcmil	-
38 to 46 m (126 to 150 ft)	152.012 mm ² csa	300 kcmil	150 mm ²
46 to 53 m (151 to 175 ft)	177.39 mm ² csa	350 kcmil	185 mm ²
53 to 76 m (176 to 250 ft)	253.35 mm ² csa	500 kcmil	240 mm ²
76 to 91 m (251 to 300 ft)	304.025 mm ² csa	600 kcmil	300 mm ²
greater than 91 m (301 ft)	380.13 mm ² csa	750 kcmil	400 mm ²

5.6.6.3 Bonding and Grounding (Earthing) Conductor Bending Requirements

Conductor bending requirements are as follows:

- Bonding and grounding conductors of all sizes **shall** maintain a minimum bending radius of 203 mm (8 in.), unless otherwise specified (TIA-607-C).

- The angle of any bend **shall not** be less than 90 degrees (ANSI/NECA/BICSI-607-2011 and TIA-607-C).
- See Figure 5-38 for conductor bending examples.

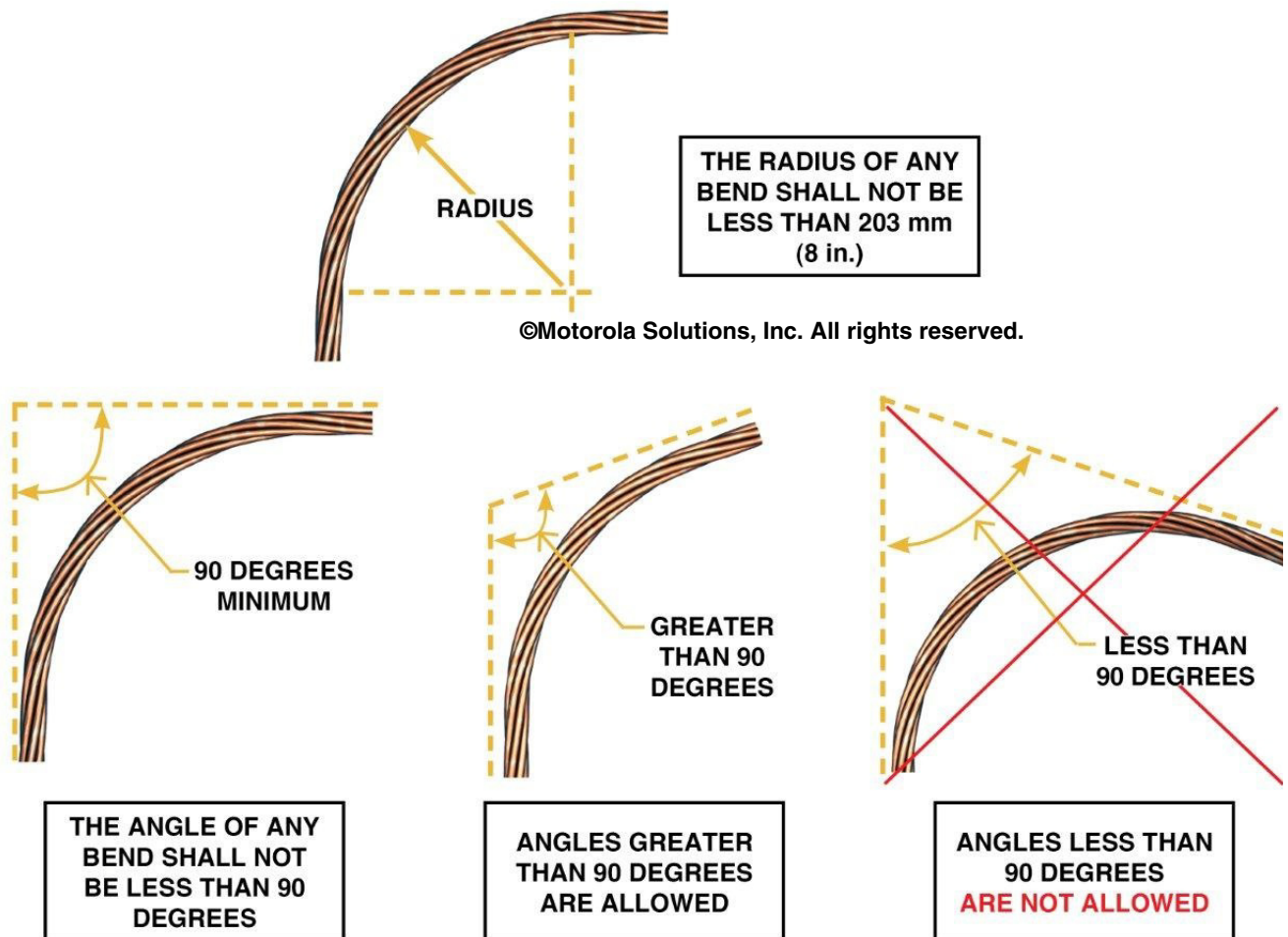

Figure 5-38 Minimum Conductor Bending Radius

5.6.6.4 Bonding and Grounding (Earthing) Conductor Separation

Conductor separation requirements are as follows:

- All bonding and grounding conductors **shall** be separated a minimum of 51 mm (2 in.) from conductors of other cable types (for example, power, RF and telecommunications) (TIA-607-C).
- Bonding and grounding conductors may come in closer proximity with other cable groups if they cross at a 90 degree angle and the crossing angle can be maintained.
 - **Exception:** Conductors can be grouped together to enter or exit a cabinet or enclosure provided the conductors are suitably separated on either side of the opening (ANSI/NECA/BICSI-607-2011 and TIA-607-C).
- To minimize potential inductive effects where routing a bonding conductor through ferrous material, the conductor **shall** be separated from the ferrous material by a distance of at least 51 mm (2 in.) (TIA-607-C). See Figure 5-39 for an example.
- If bonding conductor cannot maintain at least 51 mm (2 in.) separation from ferrous material, the conductor **shall** be effectively bonded to the ferrous material as described in “Connection Methods for Internal Bonding and Grounding (Earthing) System” on page 5-64 and applicable subsections (ANSI/NECA/BICSI-607-2011).

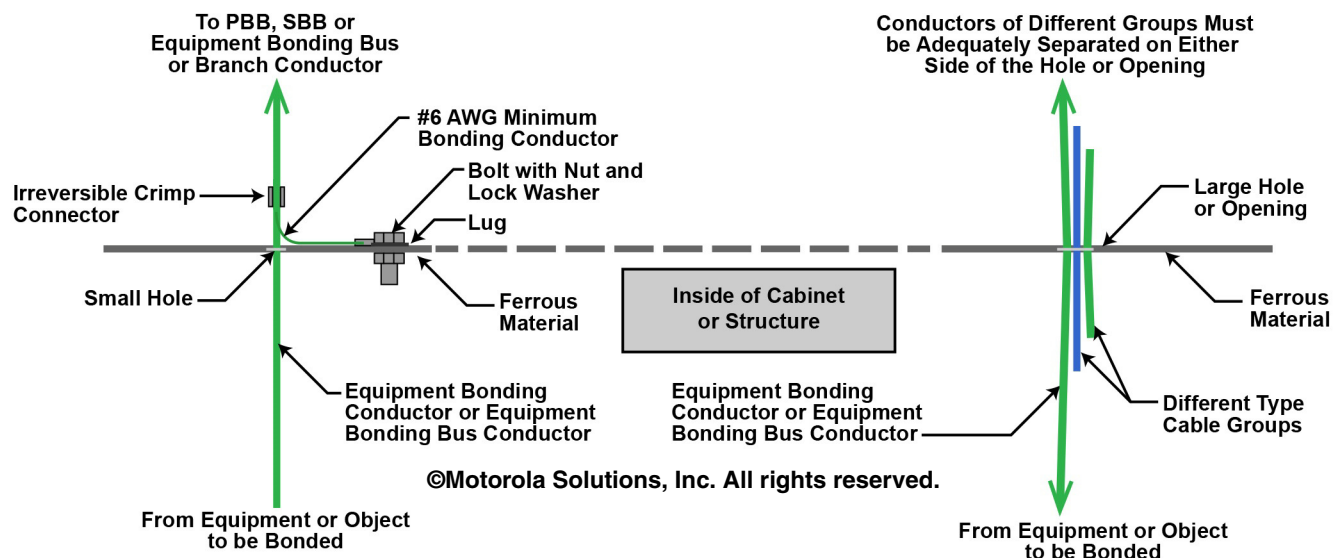

Figure 5-39 Conductor Routing Through Holes or Openings in Metallic Surfaces



NOTE

See “Primary Surge Protective Devices” on page 5-120 for primary SPD bonding conductor separation requirements.

5.6.6.5 Bonding and Grounding (Earthing) Conductor Protection

Conductor protection requirements are as follows:

- Conductors exposed to physical damage **shall** be sleeved in conduit securely attached to the surface over which it is routed (ANSI/NECA/BICSI-607-2011).
- Where metallic conduit is required for adequate protection, the conductor should be jacketed. The conductor **shall** be effectively bonded to each end of the conduit as described in “Connection Methods for Internal Bonding and Grounding (Earthing) System” on page 5-64 and applicable subsections (TIA-607-C).

5.6.6.6 Bonding and Grounding (Earthing) Conductor Support

Conductor support requirements are as follows:

- Conductors **shall** be secured or attached to surfaces as required to ensure they do not become damaged or disconnected (ANSI/NECA/BICSI-607-2011).
- Conductors **shall** be secured in a manner that permits associated equipment to be easily serviced (ANSI/NECA/BICSI-607-2011).
- Conductors **shall** be secured at no greater than 914 mm (3 ft) intervals unless otherwise specified in this chapter (ANSI/NECA/BICSI-607-2011 and TIA-607-C).
- Jacketed bonding conductors installed on a cable tray **shall** be supported at intervals no greater than 914 mm (3 ft) (see TIA-607-C for more information). The conductor may be installed inside the cable tray or outside the cable tray with suitable supporting hardware. Examples of suitable supporting hardware include cable brackets and other brackets designed for the purpose (ANSI/NECA/BICSI-607-2011). See Figure 5-40 for an example.
- If a bare conductor is installed on a cable tray (or other metallic surface), it **shall** be supported with insulated standoffs to help prevent dissimilar metal reactions and incidental contact with the tray.
- Bare conductors **shall** be solidly supported on suitable standoff insulators at intervals of no greater than 610 mm (24 in.) unless covered with Electrical Non-metallic Tubing (ENT) (TIA-607-C).

- Equipment chassis bonding conductors **shall** be secured along the cabinet or rack rail or other suitable support medium leading to the Rack Bonding Bar (RBB) or equipment bonding bus conductor.

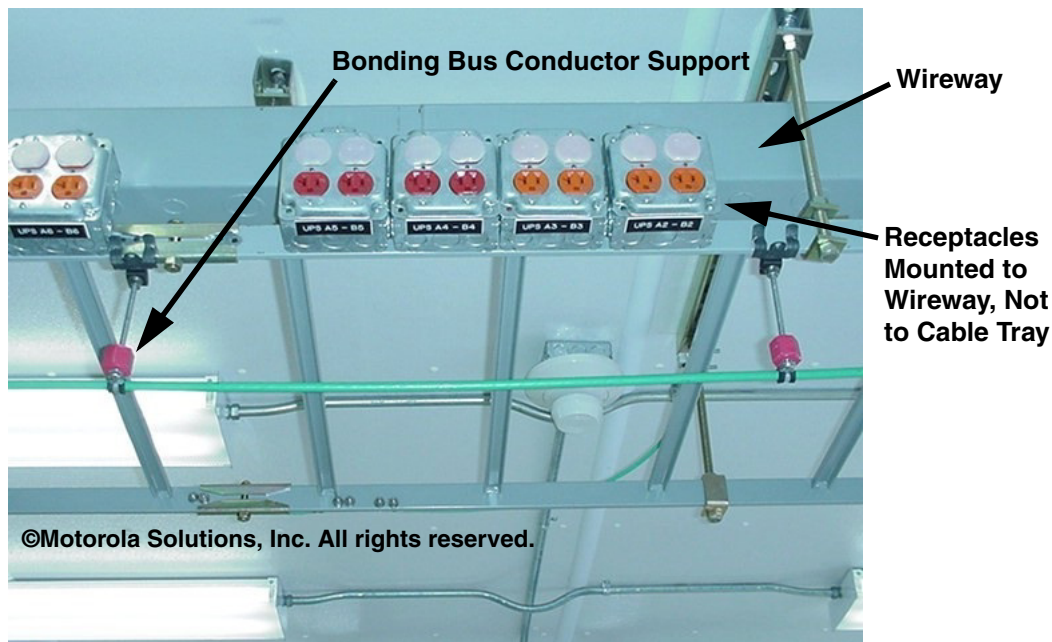

Figure 5-40 Supporting Bonding Bus Conductor on Outside of Cable Tray

5.6.6.7 Bonding and Grounding (Earthing) Conductor Routing and Installation Requirements

Conductor routing and installation requirements are as follows:

- Conductors **shall** be installed in a neat and workmanlike manner (see NFPA 70-2017, Article 110.12 and ANSI/NECA/BICSI-607-2011).
- Conductors **shall** be installed and routed so that personnel safety is not compromised (ANSI/NECA/BICSI-607-2011).
- Conductors **shall** be installed and routed so that all equipment is serviceable (ANSI/NECA/BICSI-607-2011).
- Conductors **shall** be routed with the shortest and straightest path practicable (ANSI/NECA/BICSI-607-2011).
- Conductors **shall** route toward the termination point (for example, the Primary Bonding Bar (PBB) or grounding electrode system) as follows:
 - Where a grounding electrode conductor is attached to the PBB or Secondary Bonding Bar, it **shall** be positioned on the bus bar to provide a direct flow path to the grounding electrode system.
 - Bonding conductors **shall** be positioned on bonding bars to provide direct flow paths toward the PBB and earth.
 - Connections to the bonding backbone and equipment bonding bus conductors **shall** be made with the tap conductors routed toward the PBB (ANSI/NECA/BICSI-607-2011).
 - See Figure 5-41 for an example of connecting conductors to bonding bars and tap conductors.

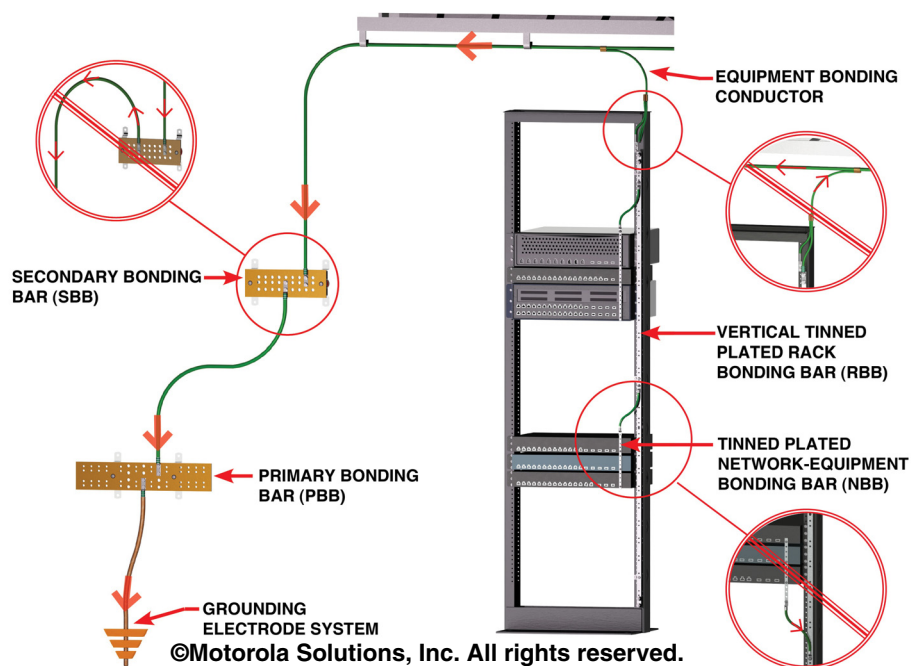

Figure 5-41 Example of Connecting Conductors to Bonding Bars and Tap Conductors

- Bare conductors **shall not** be in contact with metallic surfaces unless intended to be bonded to those surfaces.
 - Requirements for isolation **shall not** apply to flat copper strap of a Bonding Grid. See “Supplementary Bonding Network or Bonding Grid” on page 5-59.
- At points where conductors pass through holes in metallic surfaces, the surfaces **shall** be suitably protected with grommets or other material to minimize damage to the conductor or the insulating jacket (ANSI/NECA/BICSI-607-2011).
- A conductor routed through an air-handling space **shall** have an approved jacket (plenum rated) or it may be bare (see NFPA 70-2017, Article 300.22). See “Communications Cabling Requirements for Plenums and Other Spaces Used for Environmental Air” on page 9-26.
- Bare conductors routed through an air-handling **shall** be jacketed upon exiting that space (see ANSI/NECA/BICSI-607-2011 for additional information). The conductor may be spliced at this point using an approved irreversible splicing method described in “Connection Methods for Internal Bonding and Grounding (Earthing) System” on page 5-64.
- A conductor routed between floors of a building **shall** have an approved jacket (plenum or riser rated) or it may be bare. See “Communications Cabling Requirements for Risers” on page 9-29.



IMPORTANT

Conductors installed in risers or air handling spaces shall have an approved jacket or may be bare. See “Communications Cabling Requirements for Plenums and Other Spaces Used for Environmental Air” on page 9-26 and “Communications Cabling Requirements for Risers” on page 9-29.

5.6.6.7.1 Conductor Routing and Installation Above Suspended Ceilings

The bonding and grounding conductor routing and installation requirements above a suspended ceiling are as follows:

- Conductors **shall** be supported as described in “Bonding and Grounding (Earthing) Conductor Support” on page 5-42.
- Conductors installed above a suspended ceiling **shall** be supported to prevent excessive sagging.

- Conductors installed above a suspended ceiling **shall** be supported by a cable tray system or with listed hardware designed for the purpose.
- Conductors installed above a suspended ceiling **shall not** be supported by the suspended ceiling grid (see NFPA 70-2017, Articles 110.12 and 800.24). See “Support and Securing” on page 9-24 for an exception.
- Conductors **shall** follow the same requirements as described in “Support and Securing” on page 9-24.
- Conductors installed above a suspended ceiling **shall not** come in contact with light fixtures or other electromagnetic interference (EMI) generating sources.



IMPORTANT

Conductors installed in air handling spaces shall follow the requirements described in “Communications Cabling Requirements for Plenums and Other Spaces Used for Environmental Air” on page 9-26.

5.6.6.7.2 Conductor Routing and Installation Under Raised Floors

Bonding conductors are typically secured under raised floors using two methods: secured to the floor pedestals or placed directly on the sub-floor. The bonding conductor securing requirements are as follows:

For bonding conductors suspended from raised floor pedestals:

- Where a bonding conductor is suspended from raised floor pedestals, the conductor **shall** be secured at least every 914 mm (3 ft) using appropriate hardware (see Figure 5-42).

For bonding conductors placed directly on the sub-floor:

- Where the bonding conductor is placed directly on the sub-floor, it **shall** be secured at intervals not exceeding 3.66 m (12 ft) and as needed to prevent accidental displacement (see Figure 5-42).



IMPORTANT

Conductors installed in air handling spaces shall follow the requirements described in “Communications Cabling Requirements for Plenums and Other Spaces Used for Environmental Air” on page 9-26.

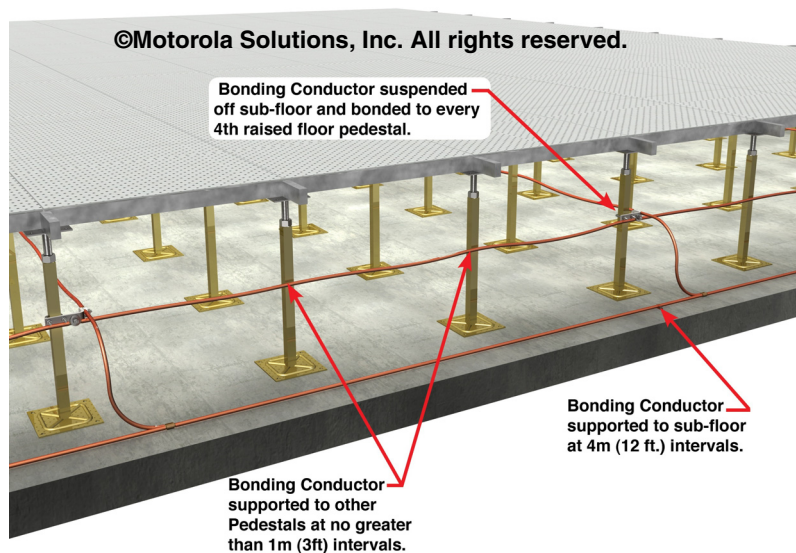

Figure 5-42 Securing Bonding Conductors Under Raised Flooring System

**NOTE**

Bonding the grid to the flooring system at every fourth pedestal is required for equal potential bonding of the flooring system (see Figure 5-62). See “Supplementary Bonding Network or Bonding Grid” on page 5-59 and “Raised Computer Floor Bonding” on page 5-115 for more information.

5.6.6.8 Equipment Bonding Conductor

An equipment bonding conductor bonds equipment chassis or frames and metallic ancillary support apparatus to the internal bonding and grounding system. Each piece of equipment **shall** have a dedicated bonding conductor bonded to the Rack Bonding Bar (RBB), bonding bus conductor, Secondary Bonding Bar (SBB) or Primary Bonding Bar (PBB) using suitable methods described within this chapter. An equipment bonding conductor from each piece of ancillary support apparatus **shall** be bonded to the PBB, SBB or internal perimeter bonding bus (IPBB) conductor using suitable methods described within this chapter.

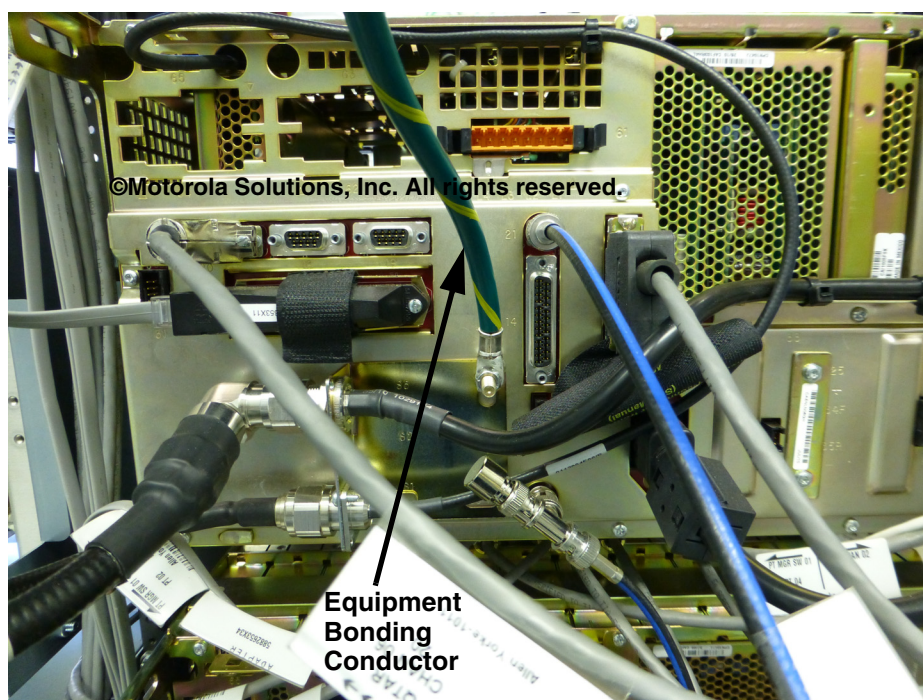

Figure 5-43 Example of Equipment Bonding Conductor

5.6.6.8.1 Equipment Bonding Conductor Location

One end of the conductor **shall** be bonded to the equipment or support apparatus using methods described within this chapter. The other end of the conductor **shall** be bonded to the bonding bus conductor, bonding grid, RBB, SBB, PBB or IPBB (ancillary support apparatus only) using suitable methods described within this chapter.

5.6.6.8.2 Equipment Bonding Conductor Specifications

Equipment bonding conductors **shall** meet the requirements of “Bonding and Grounding (Earthing) Conductors” on page 5-39 and applicable subsections. In addition, bonding conductors **shall** meet the following requirements:

- Equipment bonding conductors **shall** be 16 mm² csa (#6 AWG) or larger, unless otherwise specified.
- If the equipment bonding conductor length must exceed 4 m (13 ft) before it terminates to a bonding bus conductor (including IPBB for ancillary support apparatus), bonding grid, RBB, SBB or PBB, the conductor **shall** be increased in size according to Table 5-4.

Table 5-4 MINIMUM SIZING OF BONDING CONDUCTORS AND JUMPERS

Conductor Length	Conductor Size	International Conductor Size	Notes
-	3.3 mm ² csa (12 AWG)	4 mm ² csa	This size conductor shall be used only for bonding detachable cabinet doors and other detachable parts. See “Bonding Jumpers Specifications” on page 5-49.
-	5.26 mm ² csa (10 AWG)	6 mm ² csa	This size conductor shall be used only in special applications as permitted in this chapter. See “Surge Protective Devices” on page 5-117 and “Bonding and Grounding (Earthing) for Dispatch Centers and Network Operator Positions” on page 5-133.
Less than 4 linear meters (13 ft)	13.30 mm ² csa (6 AWG)	16 mm ² csa	
4 to 6 linear meters (14 to 20 ft)	21.15 mm ² csa (4 AWG)	25 mm ² csa	
6 to 8 linear meters (21 to 26 ft)	26.67 mm ² csa (3 AWG)	-	
8 to 10 linear meters (27 to 33 ft)	33.62 mm ² csa (2 AWG)	35 mm ² csa	

**NOTE**

See Table 5-3 for sizing of bonding conductors that exceed the distances provided in Table 5-4.

5.6.6.9 Bonding Jumpers

A bonding jumper is a short conductor (typically 46 cm (18 in.) or less) used to ensure an electrically conductive path between components (see Figure 5-44). Examples include sections of a cable tray which are required to be bonded together or sections of structural steel, roof trusses, piping systems, conduits or other metallic surfaces that are required to be bonded together to maintain electrical conductivity. A bonding jumper **shall not** be used in lieu of an equipment bonding/grounding (earthing) conductor.

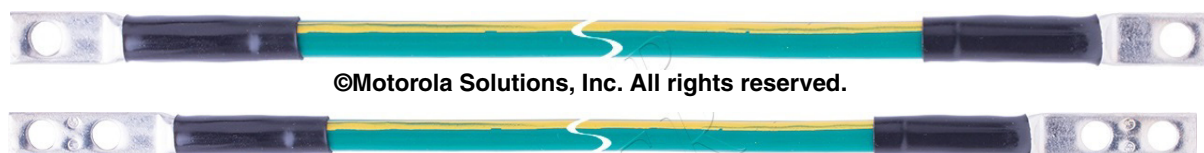
**Figure 5-44** Examples of Premanufactured Bonding Jumpers**NOTE**

Bonding jumpers described in this subsection only apply to bonding jumpers as part of the bonding network, not bonding jumpers as part of the building electrical system.



IMPORTANT

Flat braided conductors shall not be used at any location as they may introduce RF noise. See Figure 5-45 for an example of a flat braided jumper connected between shelter door and door frame. See Figure 5-109 for an example of proper door bonding.



Figure 5-45 Improper Use of Flat Braided Bonding Conductor

5.6.6.9.1 Bonding Jumpers Location

Bonding jumpers **shall** be installed to bond components of the same or similar structure together. The location will be dependent on the specific application. See Figure 5-46 for an example of a cable tray section bonding jumper.

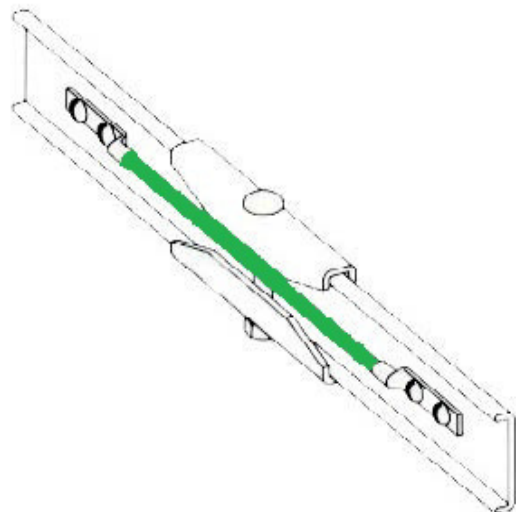

Figure 5-46 Examples of Bonding Cable Tray Sections

5.6.6.9.2 Bonding Jumpers Specifications

Bonding jumpers **shall** meet the requirements of “Bonding and Grounding (Earthing) Conductors” on page 5-39 and applicable subsections. In addition, bonding jumpers **shall** meet the following requirements:

- Bonding jumpers **shall** be 16 mm² csa (#6 AWG) or larger, unless otherwise specified.
- Bonding jumpers for equipment cabinet detachable doors (or other detachable metallic parts) **shall** be 3.3 mm² csa (#12 AWG) or larger (TIA-607-C). See Figure 5-47 for an example.
- Bonding jumpers **shall** be as short as practicable.
- Bonding jumpers **shall** be routed in as straight a line as practicable and **shall** be as free from bends as is practicable.
- If the bonding jumper length must exceed 4 m (13 ft), the conductor **shall** be increased in size according to Table 5-4.



Figure 5-47 Example of Cabinet Door Bonding Jumper

5.7 Bonding and Grounding Infrastructure Subsystems

The following subsections describe the different bonding system infrastructure subsystems:

- “Equipment Bonding Bus Conductor” on page 5-49
- “Bonding Backbone and Bonding Backbone Conductor” on page 5-53
- “Backbone Bonding Conductor” on page 5-55
- “Internal Perimeter Bonding Bus Conductor” on page 5-56
- “Halo” on page 5-59
- “Supplementary Bonding Network or Bonding Grid” on page 5-59

5.7.1 Equipment Bonding Bus Conductor

Equipment bonding bus conductors are conductors used as a convenient bonding point for multiple pieces of equipment. A single bus conductor provides a more effective bond than running multiple individual conductors, thereby reducing the possibility of a difference of potential between components. Equipment bonding bus conductors typically originate at the Primary Bonding Bar (PBB) or Secondary Bonding Bar (SBB) and radiate throughout the equipment area, generally within the cable tray system.

The far end of the equipment bonding bus conductor opposite the PBB or SBB may remain unterminated or may be terminated to a cabinet, rack, individual system component or RBB.



IMPORTANT

Do not terminate the far end (opposite the PBB/SBB) of the equipment bonding bus conductor to the cable tray system.

Equipment bonding bus conductors are used to interconnect a Rack Bonding Bar (RBB) to the PBB or SBB (see Figure 5-48). Equipment bonding bus conductors are also used to interconnect an SBB to the PBB; however, the SBB must be installed in the same equipment room/area, otherwise the requirements of a bonding backbone conductor **shall** be met (see “Bonding Backbone and Bonding Backbone Conductor” on page 5-53).



NOTE

By definition, equipment bonding bus conductors that extend beyond the area of the PBB/SBB into other rooms and/or areas of the building become bonding backbone conductors. See “Bonding Backbone and Bonding Backbone Conductor” on page 5-53 for more information.

Equipment bonding bus conductors may have branches serving as equipment bonding bus conductors for additional rows of equipment (see Figure 5-49). These equipment bonding bus conductor branches **shall** be the same size as the main equipment bonding bus conductor. The equipment bonding bus conductor branches **shall** be routed with all connections to the main equipment bonding bus conductor flowing toward the PBB or SBB (see Figure 5-50). The equipment bonding bus conductor branches **shall** be bonded to the main equipment bonding bus conductor using suitable methods described within this chapter.

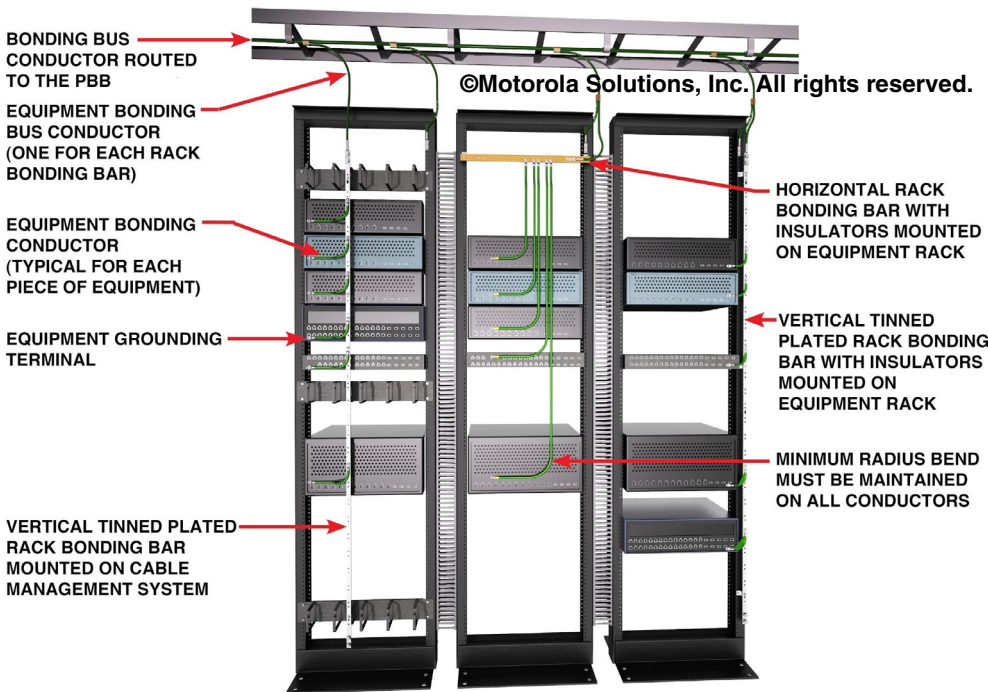

Figure 5-48 Equipment Bonding Bus Conductors Used To Bond Racks of Equipment

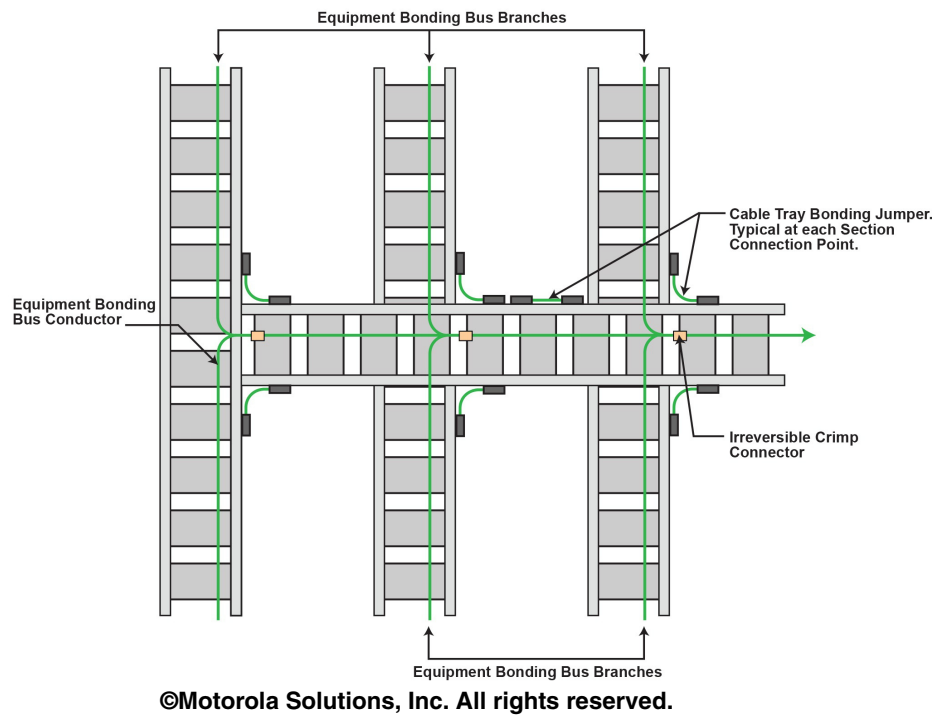

Figure 5-49 Example of Equipment Bonding Bus

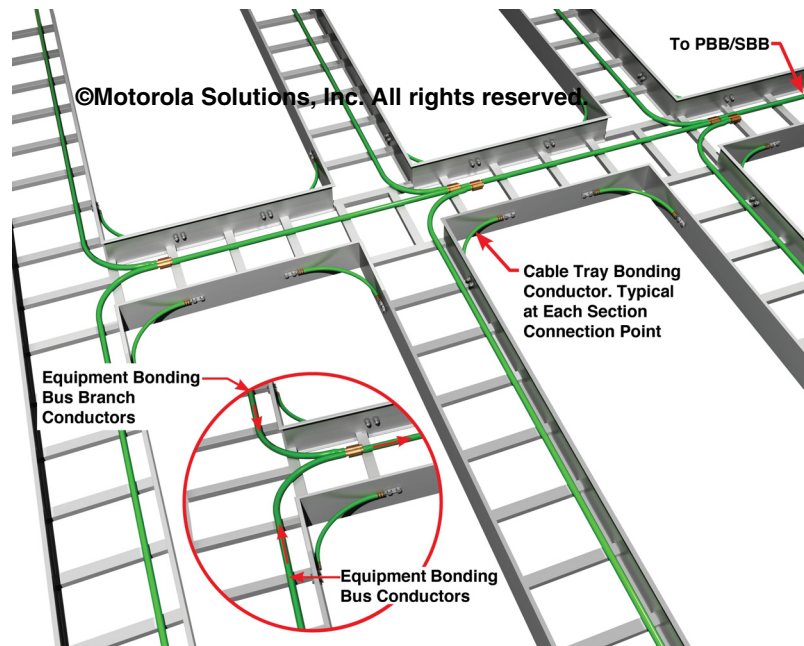

Figure 5-50 Equipment Bonding Bus Branch Conductor Routing to Primary Bonding Bar or Secondary Bonding Bar

5.7.1.1 Equipment Bonding Bus Conductor Location

One or more equipment bonding bus conductors are typically installed within the cable tray system above or below the equipment rows, as required by equipment layout and cable tray configuration. Each equipment row **shall** have an equipment bonding bus conductor installed in each cable tray cross section, as needed to ensure proper equipment bonding.

A common configuration is to have one equipment bonding bus conductor running the length of the equipment area and have bonding bus branch conductors serving additional equipment rows (see Figure 5-51).

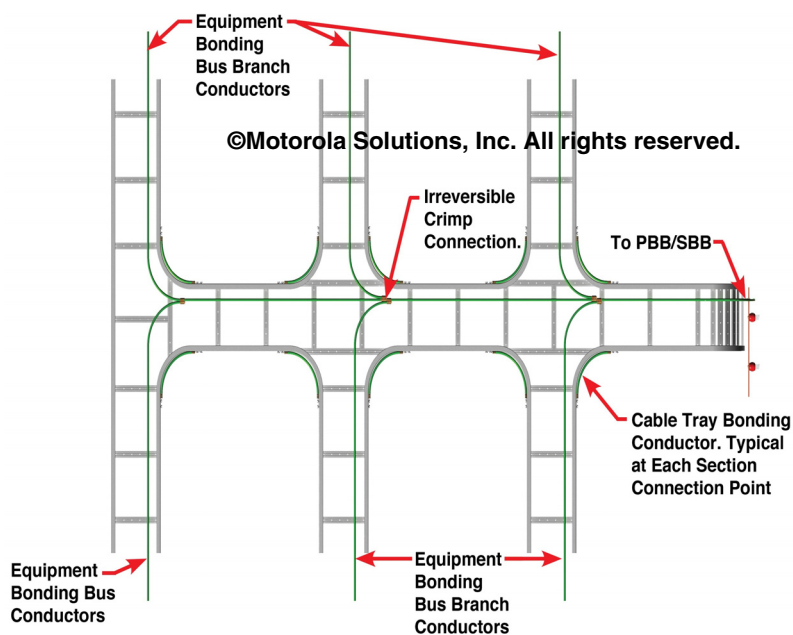

Figure 5-51 Example of Equipment Bonding Bus with Branch Conductors - Top View of Cable Trays

5.7.1.2 Equipment Bonding Bus Conductor Specifications

Equipment bonding bus conductors, including equipment bonding bus branch conductors, **shall** meet the following requirements:

- Equipment bonding bus conductors and bonding bus branch conductors **shall** be the same size.
- Equipment bonding bus conductors **shall** be 35 mm² csa (#2 AWG) or larger and **shall** be sized according to Table 5-4.
- Equipment bonding bus conductors **shall** be sized according to length based on the farthest distance away from the Primary Bonding Bar (PBB) (or from the Secondary Bonding Bar (SBB) where the SBB is part of a Bonding Backbone).
- Where the bonding bus conductor terminates to an SBB that is part of a Bonding Backbone (such as in a commercial building), the bonding bus conductor **shall** be minimally sized according to length based on the farthest distance away from the SBB.
- Equipment bonding bus conductors **shall** meet the applicable requirements, specifications and installation requirements of “Bonding and Grounding (Earthing) Conductors” on page 5-39 and associated subsections.
- All bonding bus conductors should be installed without splices. Where splices are necessary, the number of splices **shall** be kept to a minimum, and they **shall** be accessible and only located in telecommunication spaces. The joined segments **shall** be connected using exothermic welding or listed irreversible compression-type connectors. All bonding joints **shall** be adequately supported and protected from damage. See TIA-607-C.

For specific applications a copper bus bar of equal or larger size may be used instead of round conductors.

5.7.2 Bonding Backbone and Bonding Backbone Conductor

The bonding backbone conductor is a conductor used to interconnect Secondary Bonding Bars (SBB) with the Primary Bonding Bar (PBB) within multiple equipment areas in small, large and multi-story buildings (forming the bonding backbone). The intended function of the bonding backbone conductor is to reduce or equalize potential differences between all interconnected communication/electronic systems within the building. See Figure 5-52 and Figure 5-53 for examples.

Where two or more bonding backbones are used within a large or multi-story building, the communication bonding backbone conductors **shall** be bonded together with backbone bonding conductors (see “Backbone Bonding Conductor” on page 5-55). See Figure 5-52 for an example.

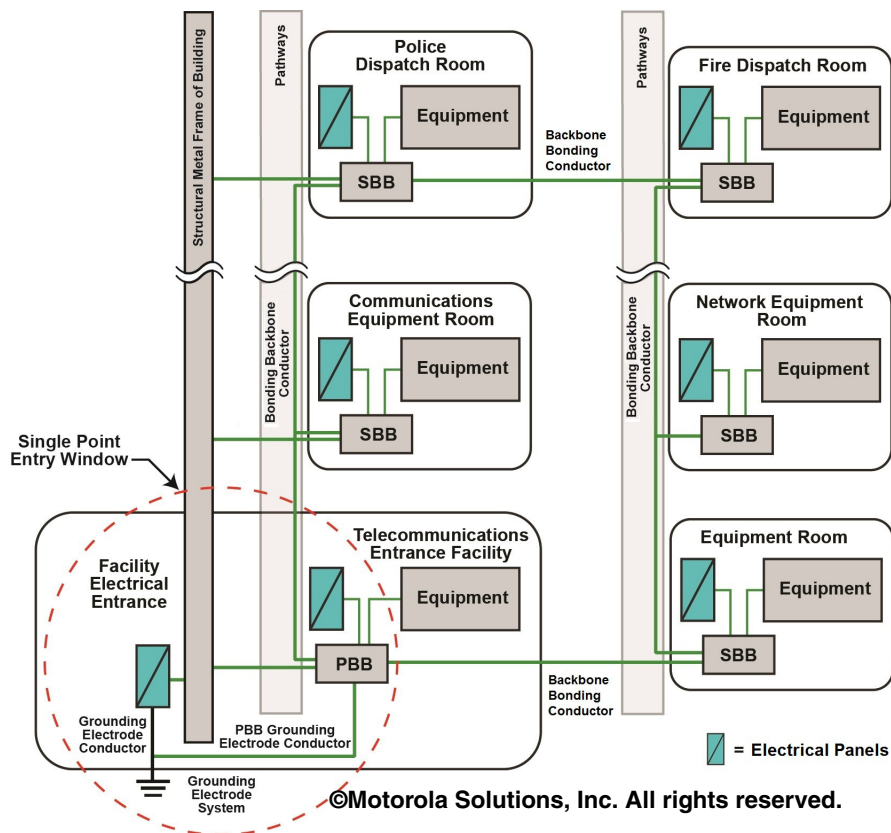

Figure 5-52 Example of Bonding Backbone in Multi-Story Building

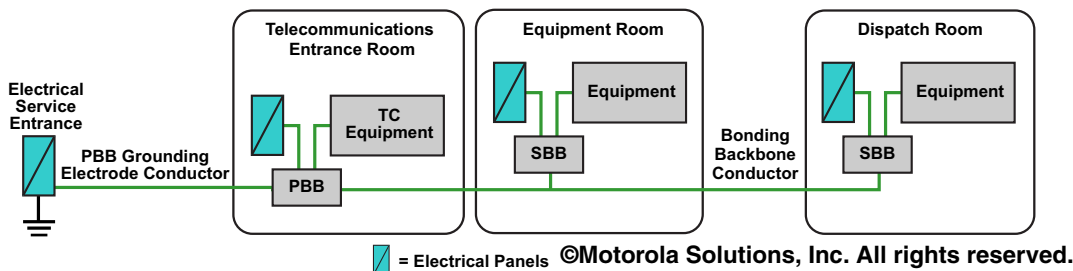

Figure 5-53 Example of Bonding Backbone in Single-Story Building



NOTE

Improved bonding performance at high frequencies can be achieved by using structural metal in place of or in addition to a bonding backbone conductor (TIA-607-C).

Where structural metal is bonded to the building’s grounding electrode system it may be used in place of a bonding backbone conductor. Before utilizing structural metal in place of a bonding backbone conductor, building plans, as-builts and specifications **shall** be reviewed to ensure the structural metal is electrically continuous or can be made so. Additionally, electrical continuity tests should be performed on the structural metal to verify electrical continuity along the paths used as bonding conductors. See TIA-607-C, section 6.3.5, for additional information.



IMPORTANT

Concrete reinforcing steel, water piping systems, cable shields, metallic pathways and conduits shall not be used as a bonding backbone conductor (TIA-607-C, sections 6.3.5.1 and 7.5.4).



NOTE

Modern building construction techniques will bond structural metal to the main AC power entrance or another grounding source. When working in existing buildings, ensure that the structural metal is bonded to a suitable ground source (for example, electrical power grounding electrode system). See TIA-607-C for additional information.

The PBB **shall** be bonded to the electrical service equipment (power) ground using a conductor of the same size or larger, as the bonding backbone conductor (TIA-607-C).

A bonding backbone conductor may serve an SBB in a large equipment area (such as a dispatch floor). This SBB becomes a primary or main SBB for that area with the purpose of providing a common bonding location as described in “Sub System Ground Bus Bar or Secondary Bonding Bar” on page 5-17. In addition, this primary or main SBB may be permitted to serve as a common bonding location for dispatch operator position SBBs (or Position Bonding Terminals).

An operator position SBB bonding conductor (operator position SBB to area primary or main SBB) **shall** be sized based on length between operator position SBB and area main SBB according to Table 5-3. This conductor is not required to be sized the same as the bonding backbone conductor. See Figure 5-54.

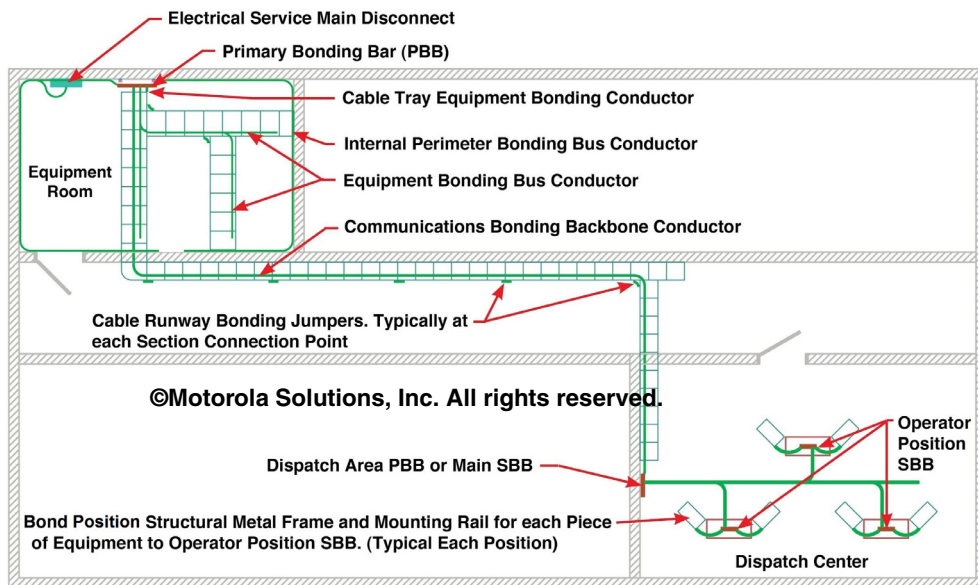

Figure 5-54 Example of Area Primary or Main Secondary Bonding Bar

An operator position SBB (or Position Bonding Terminal) **shall not** serve another operator position SBB. Any additional SBB requires a direct connection to the area primary or main SBB or bonding backbone conductor. Also see “Interposition Bonding” on page 5-139.

- The bonding backbone conductor **shall** be one continuous conductor all the way to the farthest SBB (see Figure 5-52 and Figure 5-53).
- Intermediate SBBs **shall** bond to the bonding backbone conductor using the same size conductor as the bonding backbone. Bonding of the SBB conductor to the bonding backbone conductor **shall** be made according to “Bonding to Bonding Bus Conductors” on page 5-77.

5.7.2.1 Bonding Backbone Conductor Location

The Bonding Backbone Conductor originates at the Primary Bonding Bar (PBB), extends throughout the building using the telecommunications backbone pathways and connects to Secondary Bonding Bars (SBB) in equipment rooms. The pathways **shall** be configured to maintain proper cable group separation from other cable groups and address routing to minimize the lengths of the bonding backbone conductor.

Depending on the building construction, building size, communication system requirements and the telecommunication cable pathways, one or more bonding backbone conductors may be installed (see Figure 5-52). Each bonding backbone conductor **shall** be consistent with the design of the bonding backbone cabling system, and it **shall** be installed so that it is protected from physical damage.

Typically where equipment rooms or areas are located on different floors of a large multi-story building or a large single-story building (for example, dispatch center), separate bonding backbone conductors are routed on opposite sides of the building. To equalize potential, the bonding backbone conductors are bonded together with a backbone bonding conductor (formerly called grounding equalizer conductor). See “Backbone Bonding Conductor” on page 5-55.

5.7.2.2 Bonding Backbone Conductor Specifications

Bonding backbone conductors **shall** meet the following requirements:

- Bonding backbone conductors **shall** be 35 mm² csa (#2 AWG) or larger and **shall** be sized according to Table 5-3.



IMPORTANT

Where a DC power system (see “DC Power Systems” on page 5-89) is bonded to the Primary Bonding Bar (PBB) via a bonding backbone conductor, the conductor shall be sized according to “Sizing of SBB-to-PBB Conductor Where Part of a DC System” on page 5-98.

- Bonding backbone conductors **shall** meet the applicable requirements, specifications and installation requirements of “Bonding and Grounding (Earthing) Conductors” on page 5-39 and associated subsections.
- Bonding backbone conductors **shall** be as free of splices as practicable (TIA-607-C).
 - Should splices become necessary, the splices **shall** be made using exothermic welds or listed irreversible compression-type connectors (TIA-607-C).
 - Splices **shall** be accessible (TIA-607-C).
- The bonding backbone conductor **shall** be bonded to the Primary Bonding Bar (PBB) (TIA-607-C).
- The bonding backbone conductor **shall** be continuous from the PBB to the farthest Secondary Bonding Bar (SBB). See Figure 5-52 and Figure 5-53.
 - The bonding backbone conductor **shall not** be daisy-chained from SBB to SBB (TIA-607-C).

5.7.3 Backbone Bonding Conductor

Where two or more bonding backbones are used within a multi-story building, the bonding backbones **shall** be bonded together (using the same size conductor or larger) with a backbone bonding conductor at the top floor and at a minimum of every third floor in between to the lowest floor level (see Figure 5-52).

Where two or more bonding backbones are used within a large single-story building, they **shall** be bonded together with a backbone bonding conductor at the location farthest from the Primary Bonding Bar (PBB), as practicable. Additionally, the bonding backbone conductors **shall** be bonded together every 30.5 m to 45.7 m (100 ft to 150 ft), as practicable.

Where structural metal is bonded to the building’s grounding electrode system, it may be used in place of a backbone bonding conductor. Before utilizing structural metal in place of a backbone bonding conductor, building plans, as-builts and specifications **shall** be reviewed to ensure the structural metal is electrically continuous or can be made so. See TIA-607-C for additional information.

5.7.4 Internal Perimeter Bonding Bus Conductor

It is essential that all ancillary metallic items within a communications equipment area be bonded to the building single point ground (earth). The Internal Perimeter Bonding Bus (IPBB), formerly known as the Internal Perimeter Ground (Earth) Bus (IPGB), conductors provide a suitable bonding conductor to earth for ancillary support apparatus, electrical conduits, ventilation louvers, metal door frames and other metallic items (for example, non-electronic items) that are located throughout the shelter, building or room. See Figure 5-55.

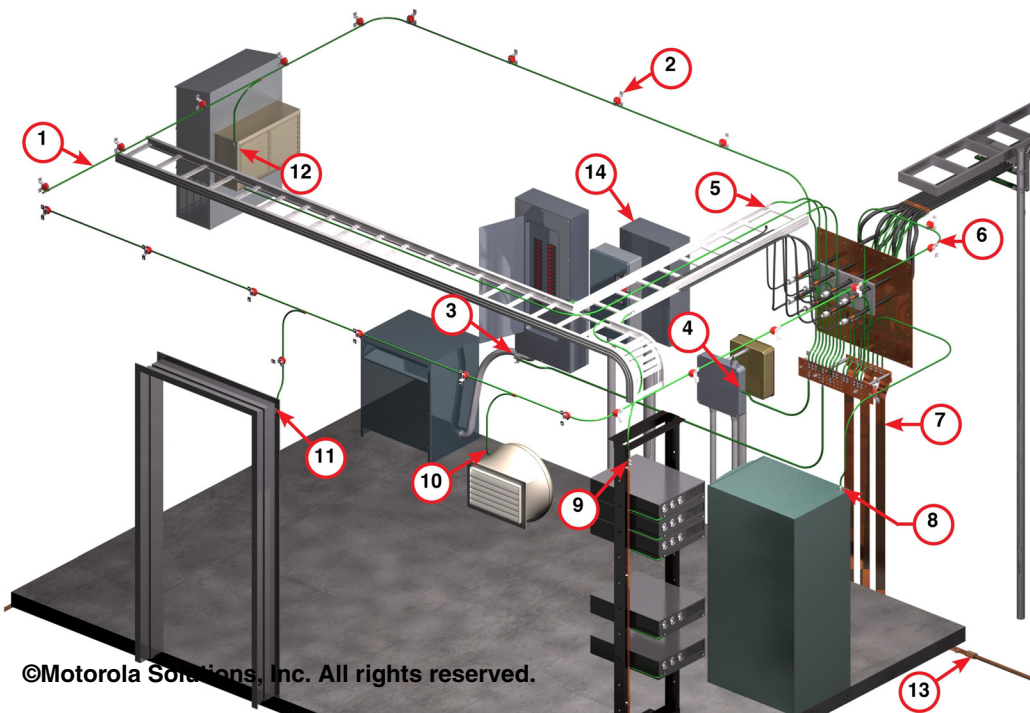

©Motorola Solutions, Inc. All rights reserved.

1	#2 AWG INTERNAL PERIMETER BONDING BUS CONNECTED TO THE PBB AT ONE END	8	UPS EQUIPMENT GROUND CONDUCTOR TO THE PBB
2	STANDOFF CLAMP WITH INSULATOR	9	EQUIPMENT BONDING BUS TO PBB
3	BOND AC ELECTRICAL SERVICE TO THE PBB	10	BOND EXHAUST FANS AND AIR VENTS TO INTERNAL PERIMETER BONDING BUS
4	BOND TELCO GROUND TO THE PBB	11	BOND DOOR FRAME TO INTERNAL PERIMETER GROUND BUS
5	BOND CABLE TRAY TO THE PBB	12	BOND HVAC TO IPBB
6	BOND IPBB TO PBB	13	SHELTER GROUND RING
7	ENTRANCE PANEL GROUND STRAPS EXOTHERMICALLY WELDED TO THE SHELTER GROUND RING	14	AC ELECTRICAL METER BOX

Figure 5-55 Example of Internal Perimeter Bonding Bus

IPBB conductors **shall** be installed in all equipment shelters, buildings or rooms specifically designed or designated for communications equipment or a generator power distribution room. An IPBB is not required in rooms or areas that are within a larger building where ancillary support apparatus (non-electronic equipment) is not present or where it is more practicable to bond this support apparatus to the Primary Bonding Bar (PBB) or Secondary Bonding Bar (SBB) with individual equipment bonding conductors. An IPBB may be installed in areas where there is a need to bond several items of support apparatus to the PBB or SBB regardless to the specific usage of the area. Motorola Solutions recommends an IPBB wherever a tower is associated with the site.

**IMPORTANT**

Internal Perimeter Bonding Bus (IPBB) conductors shall not be used for bonding communications/electronics equipment (for example, cabinets, racks or individual equipment chassis) to the PBB or SBB. The IPBB shall only be used for bonding ancillary metallic items.

5.7.4.1 Internal Perimeter Bonding Bus Specifications

In addition to the requirements described in “Bonding and Grounding (Earthing) Conductors” on page 5-39 and associated subsections, Internal Perimeter Bonding Bus (IPBB) conductors **shall** meet the following specifications:

- The IPBB conductor **shall** be 35 mm² csa (#2 AWG) or larger and **shall** be sized according to Table 5-3.
- IPBB conductors should be routed in such a way to minimize bends. Conductor bending radius **shall not** be less than 203 mm (8 in.).
 - A bending radius of 305 mm (12 in.) is recommended (ATIS-0600334.2013).
- The IPBB conductor may be bare or jacketed.
- The IPBB may be constructed from stranded or solid copper conductors, copper bars or solid copper strap of equal or larger surface area. Stranded conductors are recommended for ease of installation.
- The IPBB conductor should be installed without splices. If splices are necessary, they **shall** be established using exothermic weld or listed irreversible compression crimping connections as described in “Connection Methods for Internal Bonding and Grounding (Earthing) System” on page 5-64.

**NOTE**

The IPBB conductor may be green-jacketed or bare. Green-jacketed is preferred to help prevent incidental contact with nearby metallic objects (for example, conduits).

5.7.4.2 Internal Perimeter Bonding Bus Installation

The Internal Perimeter Bonding Bus (IPBB) is typically installed such that it encompasses the equipment area with two independently separate conductors on opposite sides of the room, forming an open loop (see IEEE 1692-2011 for more information). The two conductors should meet at a point within the equipment area, approximately opposite the Primary Bonding Bar (PBB) or Secondary Bonding Bar (SBB). At the location where the two conductors meet, they **shall** be separated by a minimum distance of 104 mm (4 in.) (see Figure 5-56 for an example).

IPBB conductors originate at (bonded to) the Primary Bonding Bar (PBB), or from a Secondary Bonding Bar (SBB) in a separate equipment area. These conductors are distributed throughout the equipment area, on interior perimeter walls just below the ceiling. Depending upon the placement of items to be bonded, one or more IPBB conductors may be installed within the same area. The IPBB conductors **shall** bond to the PBB or SBB as described in “Bonding to the Primary Bonding Bar, Secondary Bonding Bar and Rack Bonding Bar” on page 5-74.

See “Ancillary Support Apparatus” on page 5-107 for more IPBB example figures.

5.7.4.3 Internal Perimeter Bonding Bus Location

The Internal Perimeter Bonding Bus (IPBB) conductors **shall** be located horizontally along the wall close to the same height as the building entrance panel, typically 2.1 m to 2.4 m (7 ft to 8 ft) above the finished floor or within 305 mm (1 ft) below the ceiling (ATIS-0600334.2013 and IEEE 1692-2011).

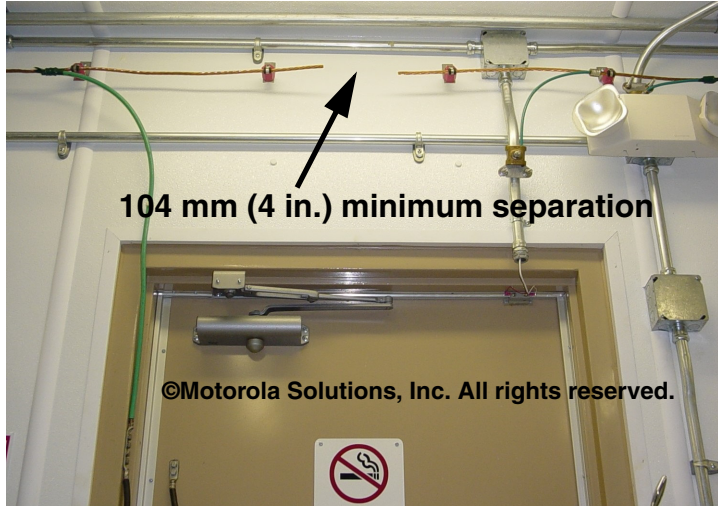

Figure 5-56 Example of Internal Perimeter Bonding Bus Conductors Separation - Opposite Primary Bonding Bar

5.7.4.4 Internal Perimeter Bonding Bus Support

In addition to the requirements described in “Bonding and Grounding (Earthing) Conductor Support” on page 5-42, the Internal Perimeter Bonding Bus (IPBB) conductors **shall** be supported as follows:

- The IPBB conductors **shall** be supported approximately 51 mm (2 in.) from the wall surface on insulated standoffs (ATIS-0600334.2013). See Figure 5-57.
- Standoffs **shall** be installed at approximately 610 mm (2 ft) intervals or as necessary to keep the conductor securely in place without noticeable sags and bends (ATIS-0600334.2013).
- IPBB conductors **shall not** be completely enclosed in metal (for example, metal sleeves passing through walls or floors, or metal clamps) (ATIS-0600334.2013).

Where transmission lines enter the equipment area at a lower point along the wall or through the floor or ceiling and the PBB is suitably located lower on the wall or on the floor or ceiling, the IPBB conductors **shall** be routed as stated in this section, with the following exception: at a point where these conductors can be readily connected to the PPB or SBB, these conductors **shall** be routed across the ceiling or downward along the wall and connected to the PBB or SBB; a vertical cable ladder of suitable design may be used for protection and support.

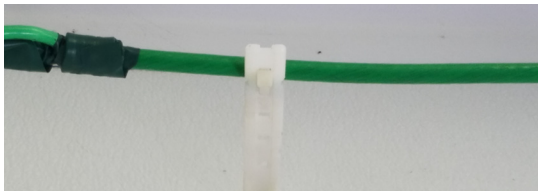

Figure 5-57 Example of Internal Perimeter Bonding Bus Mounting to Wall with Insulated Standoffs

5.7.5 Halo

The Halo or “halo ground” is similar to the Internal Perimeter Bonding Bus conductor, except that the conductor forms a continuous unbroken loop and has direct connections to the grounding electrode system in each corner.

Motorola Solutions does not recommend or endorse the halo ground because the direct connections to earth in each corner compromises the single-point grounding concept (see “Single-Point Grounding (Earthing) and the Single-Point Entry Window” on page 5-7). If a customer, site owner or end-user insists on using the halo ground, the appropriate industry standard **shall** be followed.

5.7.6 Supplementary Bonding Network or Bonding Grid

The supplementary bonding network or bonding grid (mesh bonding network or mesh-BN) is a bonding system that may be used in addition to the bonding infrastructure described in this chapter. A bonding grid is typically installed in computer or IT rooms and/or dispatch centers in order to provide for a greater degree of equal potential bonding. Bonding grids are used for bonding electronic equipment and ancillary support apparatus. Bonding grids are bonded to the bonding and grounding infrastructure (for example, Primary Bonding Bar (PBB), Secondary Bonding Bar (SBB) or bonding backbone conductor) within the building or facility; therefore, becoming part of the bonding and grounding infrastructure. See Figure 5-58 for a bonding grid example.

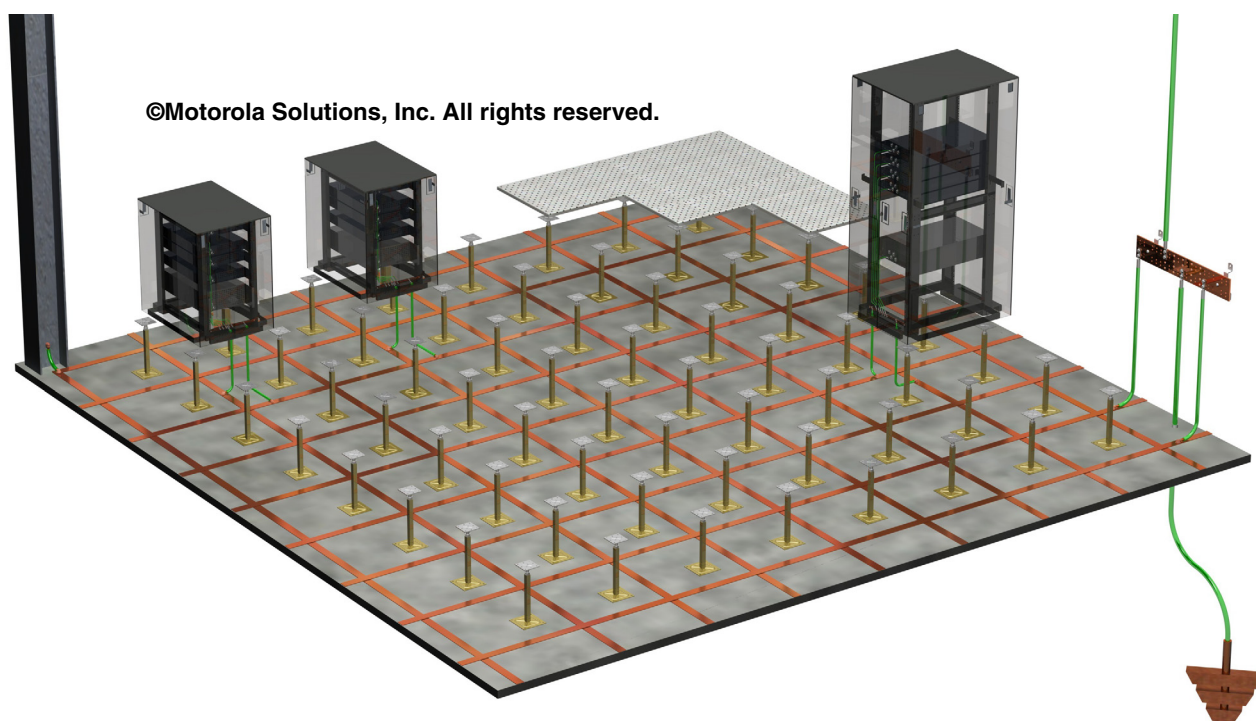

Figure 5-58 Example of Bonding Grid



NOTE

Bonding grids are typically installed under a raised computer floor system. Unless otherwise specified, under the raised floor will be the assumed installation location.



IMPORTANT

See “Bonding and Grounding (Earthing) for Dispatch Centers and Network Operator Positions” on page 5-133 for additional bonding requirements at these locations.

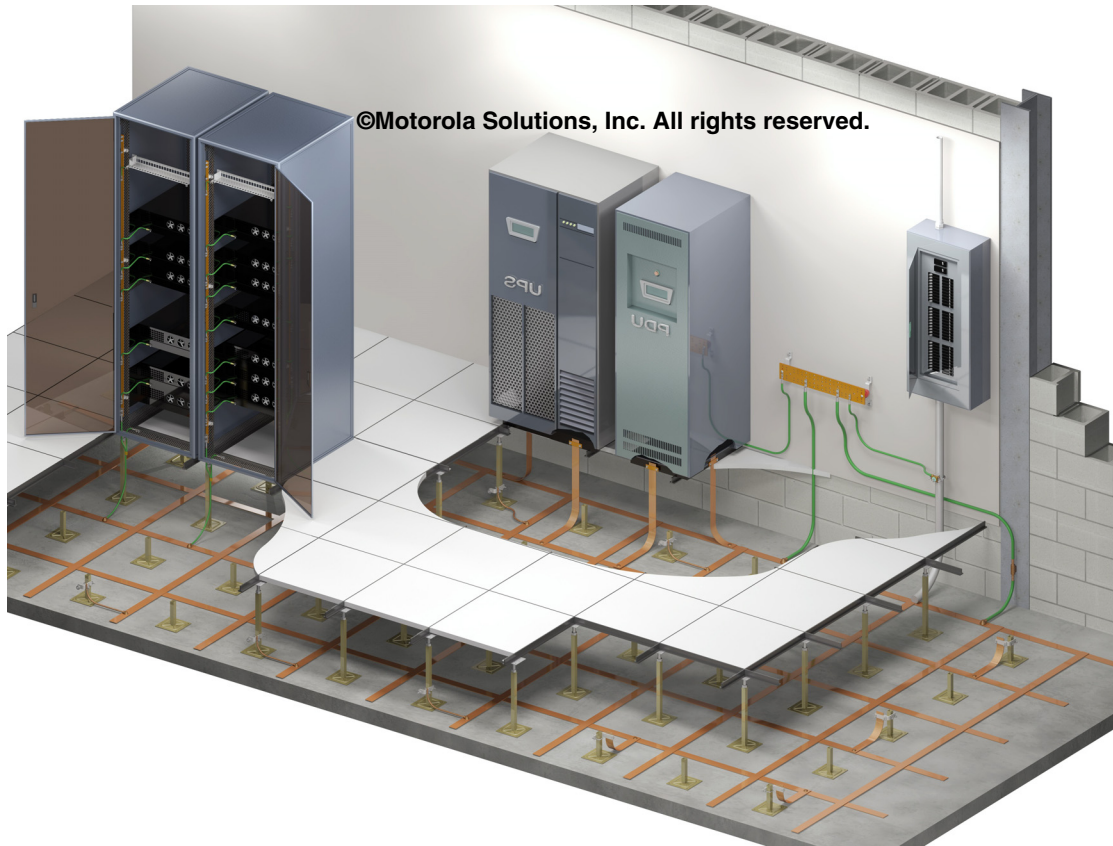

Figure 5-59 Example of Computer or IT Room Copper Strap Bonding Grid

5.7.6.1 Bonding Grid Material Requirements

The bonding grid may be constructed from flat copper strap or round conductors.

If the bonding grid is constructed from flat copper strap, the following **shall** apply:

- The bonding grid should be prefabricated (see Figure 5-60).
- The copper strap may be tinned.
- The copper strap **shall** be a minimum of 0.4 mm (.0159 in.; 26 gauge) by 50 mm (2 in.) wide (TIA-607-C, section 7.8.1).
- All crossings and joined sections **shall** be properly welded (TIA-607-C, section 7.8.1).

If the bonding grid is constructed from round conductors, the following **shall** apply:

- The minimum size conductor **shall** be a 16 mm² csa (# 6 AWG) (ATIS-0600321.2015, section 7.7.1, and TIA-607-C, section 7.8.1).
- The conductor may be bare or jacketed.
 - If the conductor is bare, it **shall** be properly secured to prevent unintentional and/or incidental bonds with metallic objects.
 - See “Bonding Grid Installation Requirements” on page 5-61.



Figure 5-60 Example of Prefabricated Copper Strap Bonding Grid

5.7.6.2 Bonding Grid Installation Requirements

The bonding grid installation requirements are as follows:

- The bonding grid conductors (or straps) **shall** be configured in a grid pattern with a conductor spacing between 0.6 m (2 ft) and 3 m (10 ft). See TIA-607-C, section 7.1.3.
 - For better high-frequency performance or lower impedance, a grid spacing of 0.6 m (2 ft) is recommended (TIA-607-C, section 7.1.3).
- The bonding grid conductors **shall** be bonded together at every intersection point using appropriate methods (TIA-607-C, section 7.8.1):
 - Exothermic welding
 - Listed irreversible compression connectors
 - Listed clamps (see Figure 5-61 for examples)
 - Listed combination clamp designed to bond floor pedestals and bonding grid conductors (see Figure 5-62)
 - Bonding grids constructed from straps **shall** be bonded together as described in “Bonding Grid Material Requirements” on page 5-60.
- The bonding grid conductors **shall** be properly secured as described in “Conductor Routing and Installation Under Raised Floors” on page 5-45.
 - Where the conductor is placed directly on the sub-floor, it **shall** be secured at intervals not exceeding 3.66 m (12 ft) and as needed to prevent accidental displacement.
 - Where the conductor is suspended from raised floor pedestals, the conductor **shall** be secured at least every 914 mm (3 ft) using appropriate hardware.
 - See Figure 5-62 and Figure 5-63 for examples of conductor securing.



NOTE

Bonding the grid to the flooring system at every fourth pedestal is required for equal potential bonding of the flooring system (see Figure 5-62). See “Raised Computer Floor Bonding” on page 5-115 for more information.

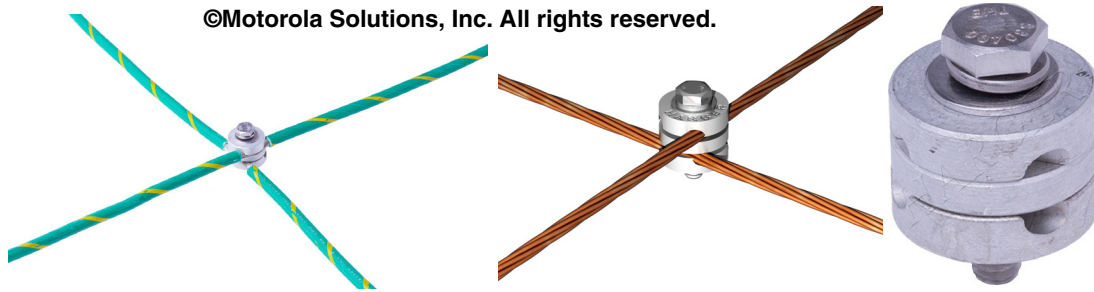

Figure 5-61 Examples of Bonding Grid Listed Clamps



Figure 5-62 Example of Combination Floor Pedestal and Grid Bonding Clamp

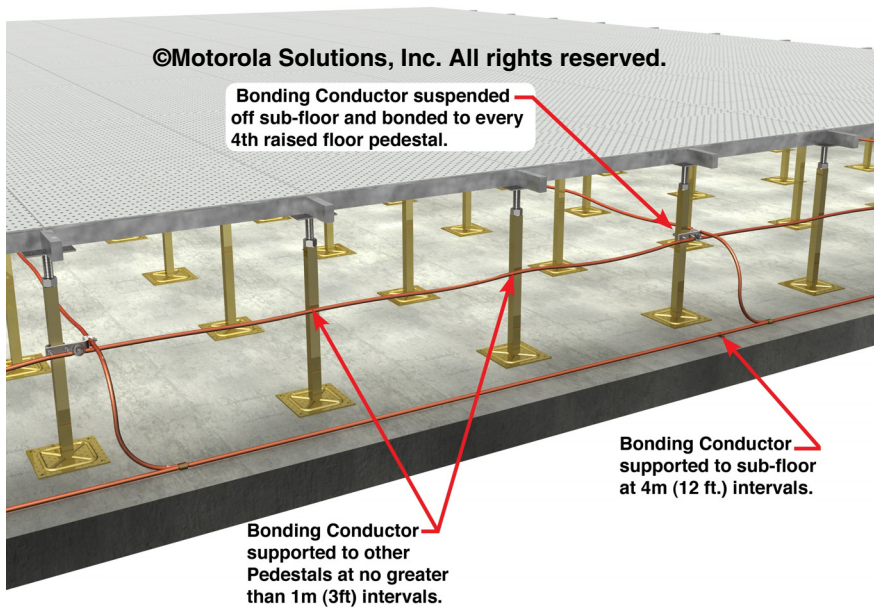

Figure 5-63 Example of Securing Grid Bonding Conductors Under Raised Flooring System

5.7.6.3 Items to be Bonded to the Bonding Grid

Bonding grids are used for bonding electronic equipment and ancillary support apparatus. The bonding grid (mesh-BN) **shall** have the following bonding connections, as applicable (see ATIS-0600321.2015, section 7.7.2, and TIA-607-C, section 7.8.1, for more information):

- Bonding to the Secondary Bonding Bar(s) (SBB) as described in “Bonding Grid Connection to Earth” on page 5-64.
- Bonding of ancillary support apparatus as described in “Ancillary Support Apparatus” on page 5-107.
 - AC panel(s) serving AC receptacles in the room
 - HVAC equipment
 - Metallic air ducts
 - Metallic conduits
 - Metallic plumbing
- Structural metal columns within the computer or IT room or a dispatch area (see Figure 5-64).
- Bonding of electronic equipment as described in “Equipment” on page 5-99.
- Bonding of cabinets and racks as described in “Cabinets and Racks” on page 5-102. See TIA-607-C, section 7.1.4.
- Bonding of network operator (dispatch) position Secondary Bonding Bars (SBB). See “Equipotential Grounding (Earthing) of the Network Operator Position” on page 5-134 for more information.
- Bonding of cable tray systems as described in “Cable Trays” on page 5-104.
- Bonding of any Power Distribution Unit (PDU) in a computer or IT room or a dispatch area according to manufacturer's recommendations and NFPA 70-2017, Article 250.122.
- Bonding of raised computer floors as described in “Raised Computer Floor Bonding” on page 5-115 and applicable subsections.
- Bonding to the bonding grid **shall** be made using exothermic welding or listed irreversible compression-type connectors (see “Bonding to Bonding Bus Conductors” on page 5-77 for more information).

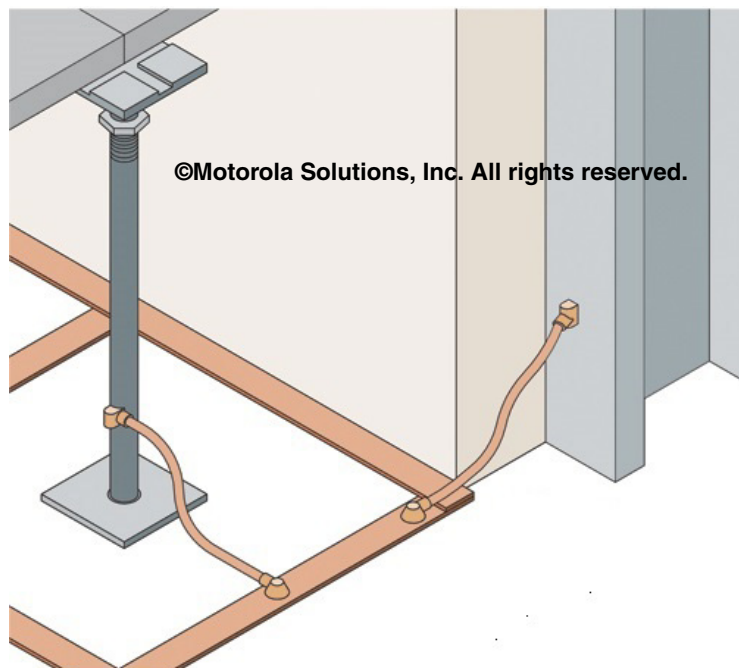

Figure 5-64 Example of Structural Metal and Floor Pedestal Bonding

5.7.6.4 Bonding Grid Connection to Earth

The bonding grid **shall** be bonded to the building internal bonding and grounding system as follows:

- Each computer/IT room and/or dispatch area **shall** contain at least one Secondary Bonding Bar (SBB) for convenient bonding of the grid and other items (TIA-607-C, section 7.1.3).
- If the facility has a bonding backbone with more than one vertical riser or horizontal backbone conductor, the computer/IT room and/or dispatch area **shall** contain at least two SBBs as practicable.
 - The SBBs **shall** be installed horizontally opposed from each other as much as practicable and installed near each respective bonding backbone conductor.
 - Each SBB **shall** bond to the nearest location on the bonding backbone.
- The SBB(s) **shall** be strategically placed in the computer/IT room or the dispatch area to allow convenient connection of the bonding grid while maintaining a flow toward earth.
- The SBB(s) **shall** bond to the Primary Bonding Bar (PBB) or bonding backbone conductor(s) using a minimum 35 mm² csa (# 2 AWG) conductor.
 - The conductor(s) **shall** also be sized according to “Bonding and Grounding (Earthing) Conductor Length and Gauge Requirements” on page 5-39.
 - See “Sub System Ground Bus Bar or Secondary Bonding Bar” on page 5-17 for more information.
- The bonding grid **shall** bond to the SBB(s) using a minimum 35 mm² csa (# 2 AWG) conductor.
 - If more than one SBB is installed (as in the case of a bonding backbone with multiple vertical risers or horizontal backbone conductors), the bonding grid **shall** bond to each SBB.
 - The conductor **shall** also be sized according to “Bonding and Grounding (Earthing) Conductor Length and Gauge Requirements” on page 5-39.
 - If only one SBB is installed, it is recommended to bond the grid to the SBB with two bonding conductors. The conductors should maintain a minimum separation from each other of 0.6 m (2 ft) from the SBB to the bonding grid.

5.8 Connection Methods for Internal Bonding and Grounding (Earthing) System

All components of the internal bonding and grounding (earthing) system and all equipment and ancillary support apparatus including, but not limited to, items listed in Table 5-8 **shall** be effectively bonded together using the following requirements and connection methods:

- “General Bonding Requirements” on page 5-65
- “Lugs and Connection Devices” on page 5-68
- “Securing Hardware” on page 5-71
- “Mechanical Bonding Requirements” on page 5-71
- “Bonding Objects in Blind Locations” on page 5-72
- “Anti-Oxidant Compound” on page 5-72
- “Exothermic Welding” on page 5-73
- “Bonding to Equipment and Ancillary Support Apparatus” on page 5-73
- “Bonding to the Primary Bonding Bar, Secondary Bonding Bar and Rack Bonding Bar” on page 5-74
- “Bonding to Bonding Bus Conductors” on page 5-77

**NOTE**

In this standard, a 2 ton (1.81 tonne) connection is considered irreversible compression; a 12 ton (10.89 metric tons) connection is considered irreversible high-compression.

**NOTE**

A tonne is also known as a metric ton.

5.8.1 General Bonding Requirements

The following requirements **shall** apply where attaching conductors to equipment, ancillary support apparatus, bonding/grounding (earth) bus bars and where attaching one conductor to another:

- Only connection devices that require the complete removal of the conductor jacket or insulation and result in a connection to the complete conductor surface area **shall** be suitable for use.
- Listed two-hole, long barrel, irreversible compression lugs are preferred over single-hole lugs and **shall** be required where two-hole lugs are referenced within this chapter.
- No more than one clamp, fitting or lug may be attached by the same bolt or bolts. An exception to this is where a jumper from a terminal strip or other internal connection point of the same equipment must be bonded to the equipment bonding/grounding conductor.
- No more than one conductor **shall** be connected by a single clamp, fitting or lug unless the clamp, fitting or lug is listed for multiple conductors.
- Solid conductors **shall** be attached to lugs and to other conductors by irreversible compression crimping process or exothermic weld. Only listed irreversible compression-type lugs and connection devices **shall** be used.
- Connections between dissimilar metals **shall not** be made unless the conductors are separated by a suitable material that is a part of the attachment device. Only attachment devices listed and approved for use with the specific dissimilar metals may be used for this purpose.
- An appropriate type of listed, conductive anti-oxidant **shall** be applied on all connections of dissimilar metals. See “Anti-Oxidant Compound” on page 5-72 for more information.
- Where threaded or tapped holes are provided for attachment purposes, a star or split type lock washer **shall** be installed under the head of the screw or bolt. See Figure 5-65 for the correct location of the star or split washer in these instances.
- Self-tapping or sheet metal type screws **shall not** be used for attaching ground or grounding conductors, except as permitted in “Bonding Objects in Blind Locations” on page 5-72. See NFPA 70-2017, Article 250.8, for additional information.
- Paint, enamel, lacquer or other nonconductive coatings **shall** be removed from threads and surface areas where connections are made (NFPA 70-2017, Article 250.12). Use of a star washer **shall not** alleviate the requirement to remove nonconductive coatings from attachment surfaces. Star or split type washers **shall not** be installed between the conductive surfaces. Proper placement of lockwasher is shown in Figure 5-65.
- All two-hole lugs **shall** have bolts in both holes with lock washers placed on the nut side of the bonding surface.

**IMPORTANT**

Do not install a washer of any kind between the ground lug and the bonding surface.

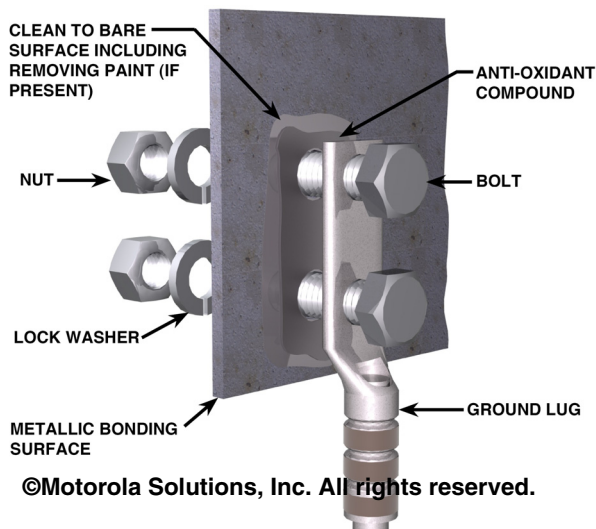

Figure 5-65 Proper Location of Washer When Connecting Ground Lug

The following methods of connection are **unacceptable** and **shall not** be used:

- Insulation piercing connectors **shall not** be used.
- Self-tapping or sheet metal type screws **shall not** be used to provide continuous and permanent electrical bonds (see NFPA 70-2017, Article 250.8, and FAA-STD-019e), except as permitted in “Bonding Objects in Blind Locations” on page 5-72.
- Captive nuts (also known as Tinnerman clips or nuts) **shall not** be used (see FAA-STD-019e).
- Aluminum connection devices **shall not** be used.
- Star or split washers **shall not** be installed between conductive surfaces. These washers may be used only under the head and/or nut of the bolt as shown in Figure 5-65.
- The series or daisy chain method of connecting a conductor from one piece of equipment to another and then to the bonding bus conductor **shall not** be permitted (see BICSI 607-2011 and FAA-STD-019e). The series or daisy chain method refers to any method of connection whereby the conductors are connected from one chassis, equipment frame or rack connection point to a second chassis, equipment frame or rack connection point and on to a third connection point, creating a series arrangement whereby the removal of the second connection point interrupts the ground path from the first chassis, equipment frame or rack. See Figure 5-66.
- Where attaching two conductors together or attaching a conductor to a lug, connections **shall not** depend solely on solder (NFPA 70-2017, Articles 250.8 and 250.70) although properly crimped connections may be soldered.
- Crimp connections **shall not** be used on solid conductors unless they are listed and approved for the application.
- Lugs equipped with mechanical set screw securing hardware for conductor connection **shall not** be used on bonding/grounding conductors.
- Conductors **shall not** extend through or beyond the clamp, fitting or lug unless the device is designed and listed to permit this conductor extension.
- Braided conductors **shall not** be used as a bonding/grounding bus conductor or equipment bonding/grounding conductor at any location (FAA-STD-019e).
- See Table 5-5 for a summary of the approved methods of bonding to the bonding and grounding infrastructure components. See Table 5-8 for more detailed information.



NOTE

See Table 5-8 for more detailed information.

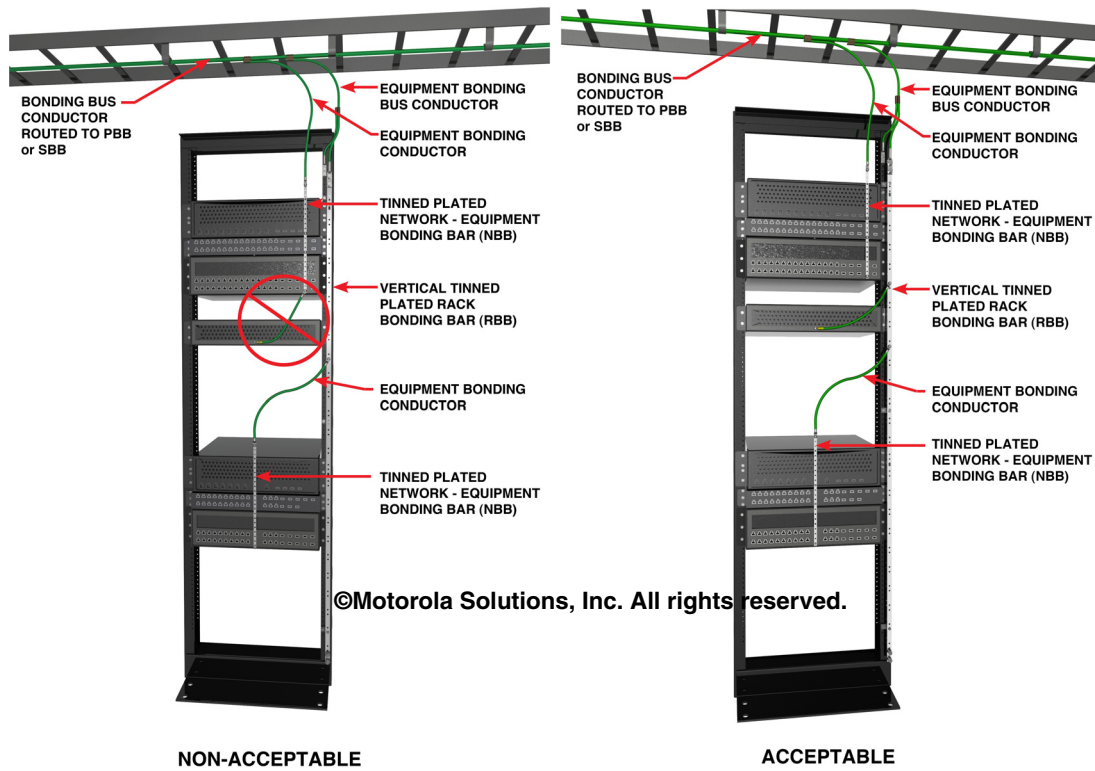

Figure 5-66 Daisy Chain Grounding Not Allowed

Table 5-5 APPROVED METHODS FOR BONDING CONNECTIONS TO THE BONDING AND GROUNDING INFRASTRUCTURE

Item	Single-Hole Lug	Two-Hole Lug	Irreversible Compression	Exothermic
PBB	-	✓	✓	✓
SBB	-	✓	✓	✓
RBB				
RBB Bonding Conductor	-	✓	-	-
Equipment	✓	✓	-	-
NBB	-			
NBB Bonding Conductor	✓	✓	-	-
Equipment	Direct connection only			
Bonding Bus Conductors	-	-	✓	✓
Bonding Grid	-	-	✓	✓

5.8.2 Lugs and Connection Devices

Interior bonding connections are typically accomplished using listed single-hole lugs, listed two-hole lugs, listed coupling devices (for example, thick or thin wall C-crimp, C-tap, H-tap) or listed clamps.

The requirements for lugs and connection devices (for example, coupling devices and clamps) are as follows:

- Lugs and connection devices **shall** be listed by a Nationally Recognized Testing Laboratory (NRTL), such as CSA or UL (ATIS-0600333.2013). See CSA C22.2 NO. 41-07 and UL 467-2007 for more information.
- Lugs and connection devices **shall** be listed for the purpose, for the type of conductor, and for the size and number of conductors used. See Figure 5-68 for an example of a lug with listed markings.
- Lugs and coupling devices used **shall** be irreversible compression or exothermically welded types (ATIS-0600333.2013). See Figure 5-67 for examples of exothermically welded lugs.

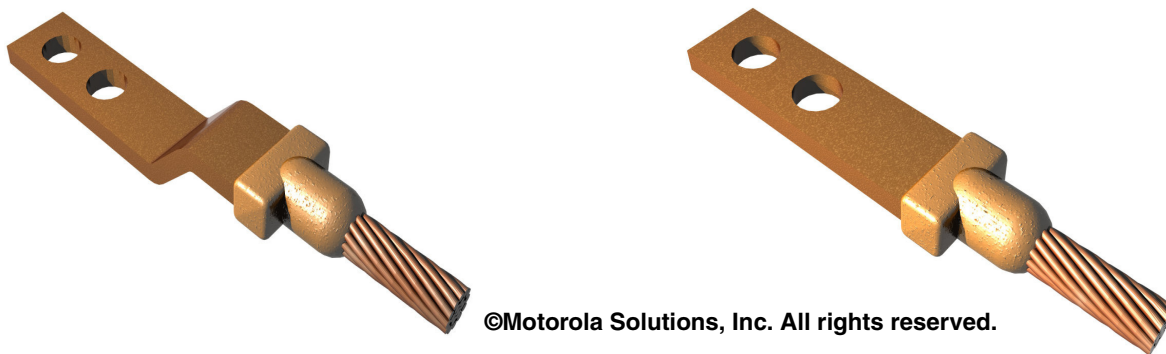

Figure 5-67 Lugs Exothermically Welded to Conductor

- Lugs used **shall** be the two-hole style, where practicable (ATIS-0600333.2013).



NOTE

Two-hole long barrel lugs are preferred over single-hole lugs and **shall** be used where practicable. Two-hole lugs prevent movement of the lug.

- Lugs and connection devices used on solid conductors **shall** be listed for use on solid conductors. See product documentation for listing details.
- Lugs used **shall** be designed for 0.64 cm (0.25 in.) minimum securing hardware, where practicable.
- Lugs and coupling/connection devices **shall** be constructed from copper, tinned-copper, tinned-copper alloy or stainless steel.
- Clamping devices connected to steel or aluminum alloy pipes/conduits **shall** be tin-plated or stainless steel.
- Clamping devices **shall** be equipped with stainless steel securing hardware for connecting the conductor to the clamp.
- Connection devices used as part of lightning protection systems **shall** be listed for the purpose.
- Lugs **shall** be attached to conductors by exothermic weld process or irreversible compression-type connection. See Figure 5-68 for an example of an irreversible compression connection and Figure 5-67 for examples of exothermic weld connections.
- Irreversible compression lugs and coupling devices **shall** be capable of being crimped to a minimum of 1.81437 tonne (2 tons) of force.
- Irreversible compression lugs and coupling devices **shall** be crimped to the conductor with a minimum of 1.81437 tonne (2 tons) of force.

**IMPORTANT**

Where aluminum lightning protection system conductors are used, appropriate listed connection devices shall be used.

**IMPORTANT**

Setscrew-style lugs are not permitted in the Internal Bonding and Grounding system. Lugs shall be the irreversible compression-type (ATIS-0600333.2013).

Figure 5-68 illustrates the typical irreversible compression crimping process for a lug. Refer to the lug and/or compression tool manufacturer for specific instructions.

Table 5-6 lists the color code for typical irreversible compression lugs. Refer to the specific compression lug documentation for details.

Table 5-6 TYPICAL IRREVERSIBLE COMPRESSION LUG COLOR CODE

Conductor Size	Lug Color Code
# 6 AWG	Blue
# 6 AWG Solid	Red
# 4 AWG	Gray
# 2 AWG	Brown
# 2 AWG Solid	White
# 1 AWG	Green
# 1/0 AWG	Pink
# 2/0 AWG	Black
# 3/0 AWG	Orange
# 4/0 AWG	Purple
250 kcmil	Yellow
500 kcmil	Brown
750 kcmil	Black



STEP 1:
Choose a lug appropriate for the application and conductor size.



STEP 2:
Strip conductor jacket to appropriate length for the lug.



STEP 3:
Verify conductor fits properly into lug. There should be no exposed conductor between the lug and the conductor jacket. The conductor should reach the inspection hole.



STEP 4:
Apply appropriate anti-oxidant compound inside lug.



STEP 5:
Apply appropriate anti-oxidant compound to conductor.

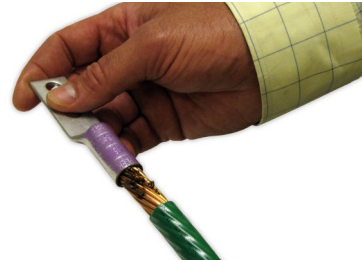

STEP 6:
Insert conductor into lug.



STEP 7:
Position the lug so it makes contact with the conductor jacket.



STEP 8:
Crimp long barrel lugs in at least two locations: place the first crimp adjacent to inspection window. Place the second crimp adjacent to the conductor jacket.

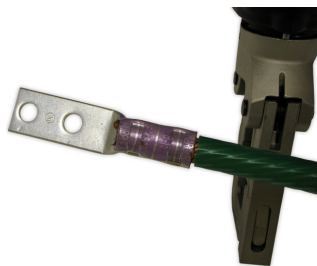

STEP 9:
Remove excess anti-oxidant compound from the lug and conductor jacket. Connection is complete.

©Motorola Solutions, Inc. All rights reserved.

Figure 5-68 Irreversible Compression Connector and Typical Crimping Tool

5.8.3 Securing Hardware

Securing hardware are the fasteners (for example, bolts, nuts, screws and washers) used to attach a bonding/grounding conductor to a clamping device or a lug/clamping device to a bus bar or metallic object. The securing hardware minimum requirements are as follows:

- All securing hardware **shall** be constructed from 300 series stainless steel (FAA-STD-019e, section 4.1.1.2.4.2), unless otherwise specified or permitted. 300 series stainless steel is commonly identified as 18-8.
- Type 316 stainless steel is recommended for corrosive environments (such as salt water environments).
- The bolts or screws **shall** be sized appropriately to match the lug or clamp size. The recommended minimum diameter bolt size is 6.35 mm (0.25 in.).
- Securing hardware **shall** be sufficiently torqued to ensure a reliable bond while not over compressing the lock washer.



IMPORTANT

Careful attention must be given when selecting hardware pieces to ensure no other metal types are inadvertently used. Mixing other metal types with the stainless steel can cause severe corrosion, resulting in an ineffective electrical bond and a potential RF interference point.



NOTE

300 series stainless steel (commonly identified as 18-8) has very little attraction to a magnet, whereas 400 series stainless steel does.

5.8.4 Mechanical Bonding Requirements

Bonding to communication system devices, ancillary equipment or bus bars typically require the use of mechanical bonding connections. See Figure 5-65 for bonding examples. The mechanical bonding requirements are as follows:

- Lugs and clamps **shall** meet the requirements of “Lugs and Connection Devices” on page 5-68.
- Paint, enamel, lacquer and other nonconductive coatings **shall** be removed from threads and surface areas where connections are made to ensure good electrical continuity (NFPA 70-2017, Article 250.12).



NOTE

Use of a star washer does not alleviate the requirement to remove nonconductive coatings from attachment surfaces. Star washers should only be used as a lock washer. See Figure 5-65 for proper star/lock washer location.

- Bonding surfaces **shall** be cleaned to remove dirt, corrosion and oxidized material on the connection surface area (ATIS-0600334.2013, section 9).
- All mechanical joints **shall** be protected with a listed conductive anti-oxidation compound (ATIS-0600334.2013, section 9). See “Anti-Oxidant Compound” on page 5-72.
- After cleaning of the mating surfaces, the bond members should be assembled or attached as soon as practicable. Assembly should be completed within 30 minutes. If more than two (2) hours is required between cleaning and assembly, a temporary protective coating must be applied (MIL-HDBK-419A).
- After bonding to a painted or galvanized steel structure, the area **shall** be thoroughly cleaned and coated with an approved corrosion inhibitor (such as an enamel or zinc-enriched paint).
- Two-hole long barrel lugs are preferred over single-hole lugs and **shall** be used where practicable. Two-hole lugs prevent movement of the lug.
- Where two-hole lugs are used, securing hardware **shall** be used in both holes.

- Lugs and clamps **shall** be secured to the surface using a combination of nut, bolt and lock washer where both sides of the bonding surface are accessible (see Figure 5-65).
- Bolts **shall** be tightened sufficiently to maintain the contact pressures required for effective bonding, but **shall not** be over-tightened to the extent that deformation of bond members occurs (FAA-STD-019e, section 4.1.1.2.4.2).
- Where connecting ground lugs or fasteners to ancillary equipment, such as air conditioners and vent hoods, a lock washer **shall** be placed on the nut side. See Figure 5-65 for an example.

5.8.5 Bonding Objects in Blind Locations

Bonding locations where the rear of the object being bonded is inaccessible for installation of a nut are commonly known as blind locations. Common examples of blind locations are door frames, metallic siding and vent covers.

Follow all requirements in “Connection Methods for Internal Bonding and Grounding (Earthing) System” on page 5-64 and all subsections as applicable. Two-hole lugs **shall** be used where practicable. A lock washer **shall** be installed between the lug and the bolt/screw head.

The following methods may be used where the metallic object to be bonded is thick enough to engage at least two threads from the fastener:

- Drill and tap the appropriate size hole(s) in the object for the size fastener being used. Attach the ground lug using stainless steel hardware.
- Drill the appropriate size hole(s) in the object for the size fastener being used. Attach the ground lug using stainless steel thread-forming machine screw(s).



NOTE

A typical thread-forming machine screw used in this application has approximately 32 threads per inch.

The following methods may be used where the metallic object is not thick enough to engage at least two threads from the fastener:

- Attach the ground lug using an existing screw already present for securing the metallic object. If practicable, a two-hole lug **shall** be used. Where a two-hole lug is used, secure the second hole using one of the following additional options.
- Attach the ground lug using appropriate stainless steel screw(s) that penetrates to wood or metal framing.
- Drill an appropriate size hole and install an internally threaded rivet. Attach the ground lug using stainless steel hardware.
- Punch a small hole in the metal using an awl. Attach the ground lug using stainless steel thread-forming machine screw(s). The practice of punching a hole with an awl may help create more surface area for thread contact.
- In some applications the use of stainless steel sheet metal screws may be the only available option to bond some items (such as metallic siding). Sheet metal screws **shall** be used only where no other option is available. A suggested best practice is to first punch a small hole in the metal using an awl.

5.8.6 Anti-Oxidant Compound

Anti-oxidant compound is used on mechanical bonds to help prevent oxidation and ensure a good electrical connection. All mechanical joints **shall** be protected by a listed conductive anti-oxidant compound (ATIS-0600333.2013, section 9.2.2, and ATIS-0600334.2013, section 9). The requirements for anti-oxidant compounds are as follows:

- The anti-oxidant compound **shall** be the conductive type and **shall** be designed for use in electrical connections.
- The anti-oxidant compound **shall** be listed by a Nationally Recognized Testing Laboratory (NRTL).
- The anti-oxidant compound **shall** be listed for the type(s) of metal it is applied on.
- The anti-oxidant compound **shall** be used according to the manufacturer's instructions.
- See Table 5-7 for a matrix of suggested anti-oxidant compounds for each combination of connection device and bonding surface:

- Zinc anti-oxidant compound (typically gray colored) should be applied between galvanized steel, steel or aluminum bonding surfaces and stainless steel or tin-plated connection devices.
- Zinc anti-oxidant compound (typically gray colored) should be applied between tin-plated bus bars and tin-plated lugs.
- Copper anti-oxidant compound (typically copper colored) should be used between copper, bronze or brass bonding surfaces and copper, copper alloy or tin-plated connection devices.
- Copper anti-oxidant compound (typically copper colored) should be used between copper bus bars and tin-plated lugs.
- Copper anti-oxidant compound should be used between copper or copper alloy bonding surfaces and stainless steel lugs.
- Copper or zinc anti-oxidant compound may be used between tin-plated bonding surfaces and stainless steel lugs.

Table 5-7 ANTI-OXIDANT COMPOUND MATRIX - CONNECTION DEVICE VERSUS BONDING SURFACE

Connection Devices	Bonding Surfaces				
	Copper or copper alloys (for example, bronze and brass)	Tin-plated	Steel	Galvanized steel	Aluminum
Copper or copper alloys	Copper	Copper	Copper or copper alloys are not approved as connection devices to steel, galvanized steel or aluminum bonding surfaces. Tin-plated or stainless steel connection devices are required.		
Tin-plated	Copper	Gray/Zinc	Gray/Zinc	Gray/Zinc	Gray/Zinc
Stainless steel	Copper	Copper or Gray/Zinc	Gray/Zinc	Gray/Zinc	Gray/Zinc

NOTE: See anti-oxidant compound manufacturer instructions.

5.8.7 Exothermic Welding

See “Exothermic Welding” on page 4-64 for details.

5.8.8 Bonding to Equipment and Ancillary Support Apparatus

In addition to the applicable requirements from “General Bonding Requirements” on page 5-65, the following requirements **shall** apply where attaching equipment bonding/grounding conductors to equipment and ancillary support apparatus:

- Each electronic equipment chassis **shall** have a separate and independent equipment bonding conductor. See “Equipment” on page 5-99 for examples.



NOTE

Use of a star washer does not alleviate the requirement to remove non-conductive coatings from attachment surfaces because the star washer does not provide enough contact surface area.

- Connections to steel and galvanized steel pipes, conduit or other round member items **shall** be made using a UL 467 listed, bolted clamp with stainless steel securing hardware or other suitable listed means. In high humidity areas, the clamps **shall** be stainless steel or tin-plated UL 467 listed to prevent galvanic corrosion.
- Connections to vibrating or movable items **shall** be made by using an exothermic weld or an irreversible compression-type two-hole lug.

- Connections to structural metal (building steel) **shall** be made by using an exothermic weld, listed irreversible high compression-type connection or listed tin-plated flange-type bonding connector that is equipped with two securing bolts. Figure 5-69 shows examples of acceptable bonding connections to structural metal (building steel).

©Motorola Solutions, Inc. All rights reserved.

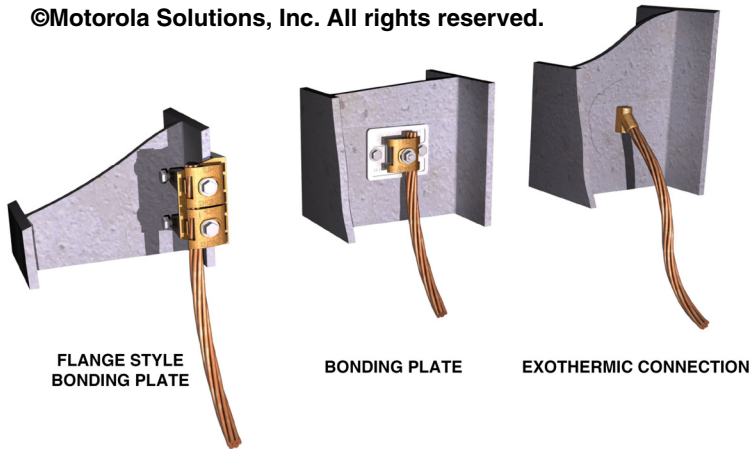

Figure 5-69 Examples of Acceptable Structural Building Steel Bonding Connections

5.8.9 Bonding to the Primary Bonding Bar, Secondary Bonding Bar and Rack Bonding Bar

All applicable general bonding requirements and the bonding requirements listed in this section **shall** apply where attaching bonding/grounding (earthing) conductors, grounding electrode conductors, bonding bus/ground bus conductors and equipment bonding/grounding conductors to the Primary Bonding Bar (PBB), Secondary Bonding Bar (SBB) or Rack Bonding Bar (RBB):

Conductors **shall** meet the physical and installation requirements of “Bonding and Grounding (Earthing) Conductors” on page 5-39 and all subsections. Figure 5-70 shows proper lug attachment to the PBB or SBB.

©Motorola Solutions, Inc. All rights reserved.

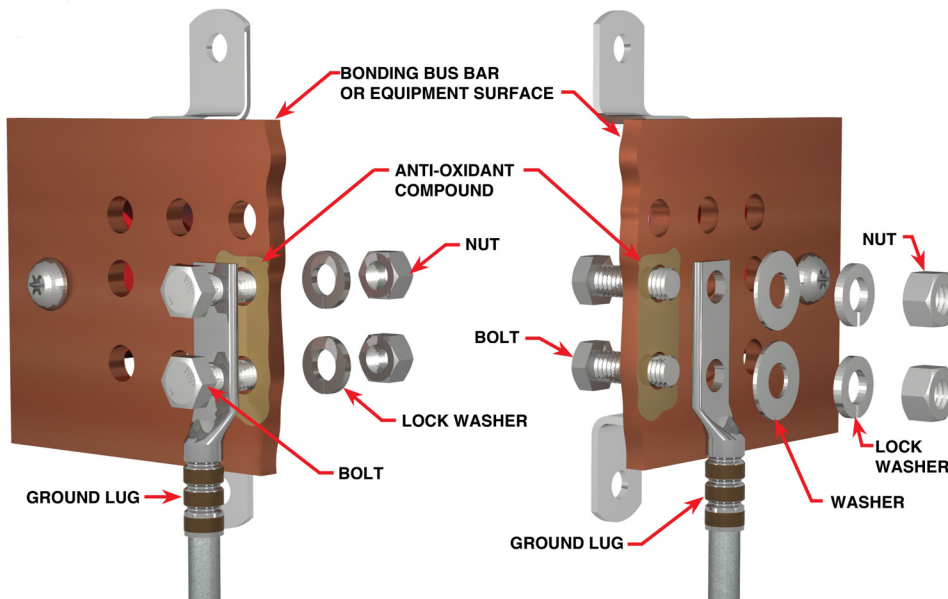

Figure 5-70 Fastening Hardware Configurations for Two-Hole Lug Attachment to Primary or Secondary Bonding Bar

5.8.9.1 Connection to the Primary Bonding Bar

Connections to the Primary Bonding Bar (PBB) **shall** utilize exothermic welding, irreversible high-compression connection, listed irreversible compression two-hole lugs or listed exothermic two-hole lugs (TIA-607-C). Such connections include, but are not limited to, the following:

- PBB grounding electrode conductor
- Bonding backbone conductor
- Bonding bus conductor
- Individual equipment (electronic or ancillary) bonding conductor

See Table 5-8 for more information.



IMPORTANT

Single-hole lugs shall not be used.

5.8.9.2 Connection to the Secondary Bonding Bar

Connections to the Secondary Bonding Bar (SBB) **shall** utilize exothermic welding, irreversible high-compression connection, listed irreversible compression two-hole lugs or listed exothermic two-hole lugs (TIA-607-C). Such connections include, but are not limited to, the following:

- SBB grounding electrode conductor (for SBB serving an entry location)
- Bonding backbone conductor
- Bonding bus conductor
- Individual equipment (electronic or ancillary) bonding conductor

See Table 5-8 for more information.



IMPORTANT

Single-hole lugs shall not be used.

5.8.9.3 Connection to the Rack Bonding Bar

Connections to the Rack Bonding Bar (RBB) from the RBB bonding conductor **shall** utilize listed irreversible compression two-hole lugs or listed exothermic two-hole lugs (TIA-607-C). See “Rack Bonding Bar Specifications” on page 5-28 and Table 5-8.

Connections to the RBB from individual pieces of equipment may use the two-hole lugs listed in the preceding two sections and may use single-hole irreversible compression lugs or listed single-hole exothermic lugs. See Figure 5-71 for an example of an irreversible compression two-hole lug feeding the RBB and single-hole lugs on the equipment bonding conductors.

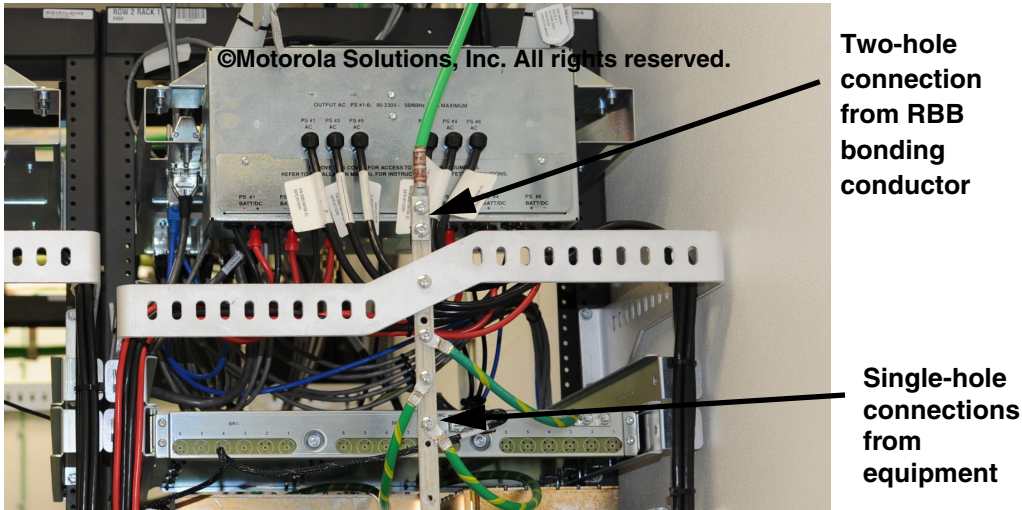

Figure 5-71 Example of Connection to Rack Bonding Bar

5.8.9.4 PANI Method

Some customers such as cellular operators may require conductors be bonded to the Primary Bonding Bar (PBB) in a specific sequence or order determined by the conductor's origin or the type of equipment being bonded to the PBB. One of these methods, known as PANI, allocates specific areas of the PBB for bonding surge energy Producers, Absorbers, Non-isolated equipment and Isolated equipment. An example of this type of configuration is shown in Figure 5-72. This method is not required for compliance with this installation standard and is provided for reference only. See ATIS-0600313.2013 and ATIS-0600333.2013 for additional information on this method of bonding to the PBB.

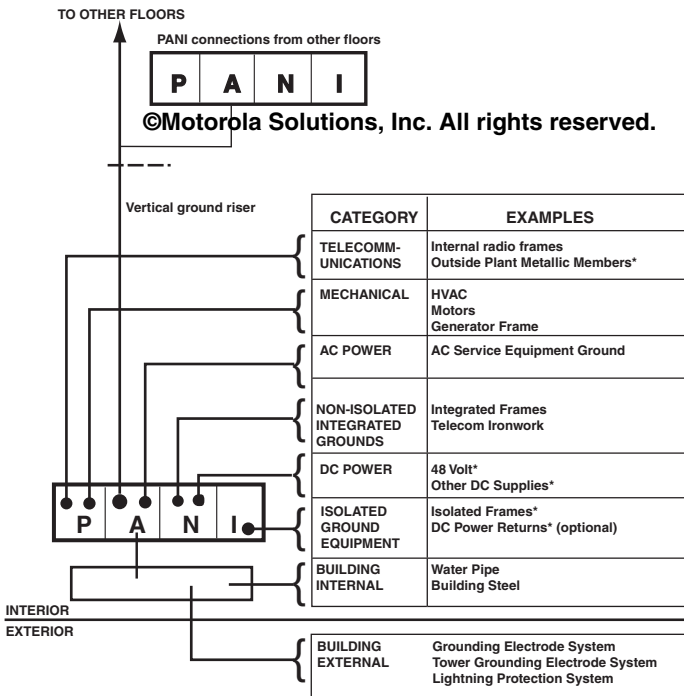

Figure 5-72 PANI Grounding System Sequence

PANI ©Motorola Solutions, Inc. All rights reserved.			
Surge Producers	Surge Absorbers	Non IGZ	Isolated Ground Zones (IGZ)
<ul style="list-style-type: none"> • RF SPD • AC Equip. • Tel. SPD • Cable Shields • ESD 	<ul style="list-style-type: none"> • Building Steel • AC NG Bond • Water Line • Metallic Piping • Concrete Encased Electrode • Ground Rings 	<ul style="list-style-type: none"> • +48VDC GND. • -24VDC GND. • Cable Tray Sys. • Equip. Frame • Battery Racks • Ancillary Equip. 	<ul style="list-style-type: none"> • Logic Ground. • IG Zones

Figure 5-73 PANI Bus Bar Configuration

5.8.10 Bonding to Bonding Bus Conductors

All applicable general bonding requirements **shall** apply where attaching bonding bus branch conductors and equipment bonding conductors to a bonding bus conductor. The following requirements also apply:

- All bonding bus conductors should be installed without splices. Where splices are necessary, the number of splices should be kept to a minimum, and they **shall** be accessible and only located in telecommunication spaces. The joined segments **shall** be connected using exothermic welding or listed irreversible compression-type connectors. All bonding joints **shall** be adequately supported and protected from damage. See TIA-607-C.
- Bonding bus branch conductors **shall** be routed toward the Primary Bonding Bar (PBB) or Secondary Bonding Bar (SBB) at the point of connection to the main bonding bus conductor. See Figure 5-74.
- Bonding bus branch conductors **shall** be connected to the main bonding bus conductor using exothermic welding or listed irreversible compression-type connectors. Connection points **shall** be taped with a suitable green tape or otherwise isolated from contact with the cable tray or other metallic surfaces.
- Equipment bonding conductors **shall** be routed toward the PBB or SBB at the point of connection to the bonding bus conductor. Equipment bonding conductors **shall** be connected to the bonding bus conductor using exothermic welding or listed irreversible compression-type connections. Connection points **shall** be taped with a suitable green tape or otherwise isolated from contact with the cable tray or other metallic surfaces. See Figure 5-75 and Figure 5-76.
- Equipment bonding conductors **shall** be connected so that the removal of a connection will not break the bonding path to any other piece of equipment or ancillary support device.
- Multiple connections **shall not** be made to one attachment point on the bonding bus conductor unless this connection is made using exothermic welding or listed irreversible compression-type connector listed for multiple conductors. In all cases the connection means **shall** be listed for the size and number of conductors to be connected.



IMPORTANT

Split bolt connection devices are not permitted.

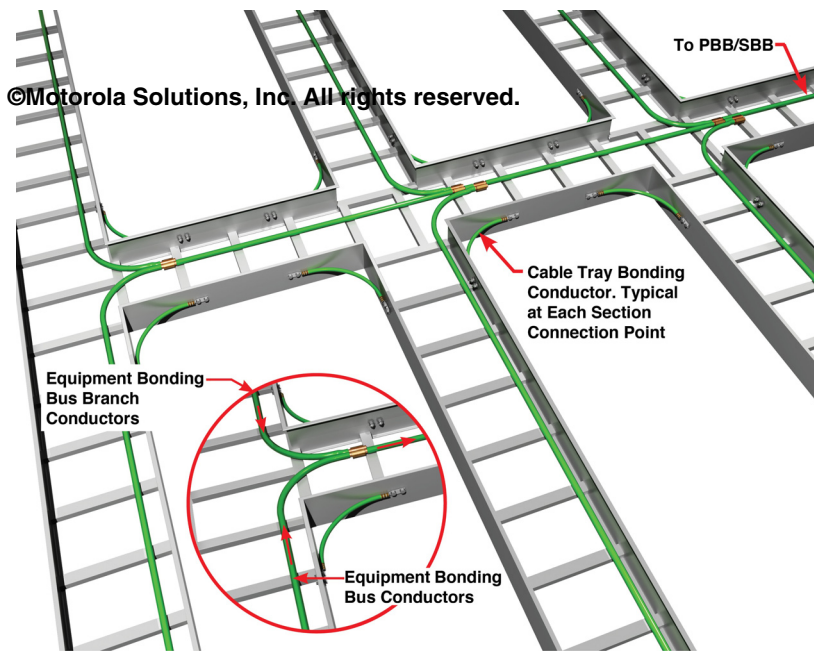

Figure 5-74 Examples of Bonding to Bonding Bus Conductor

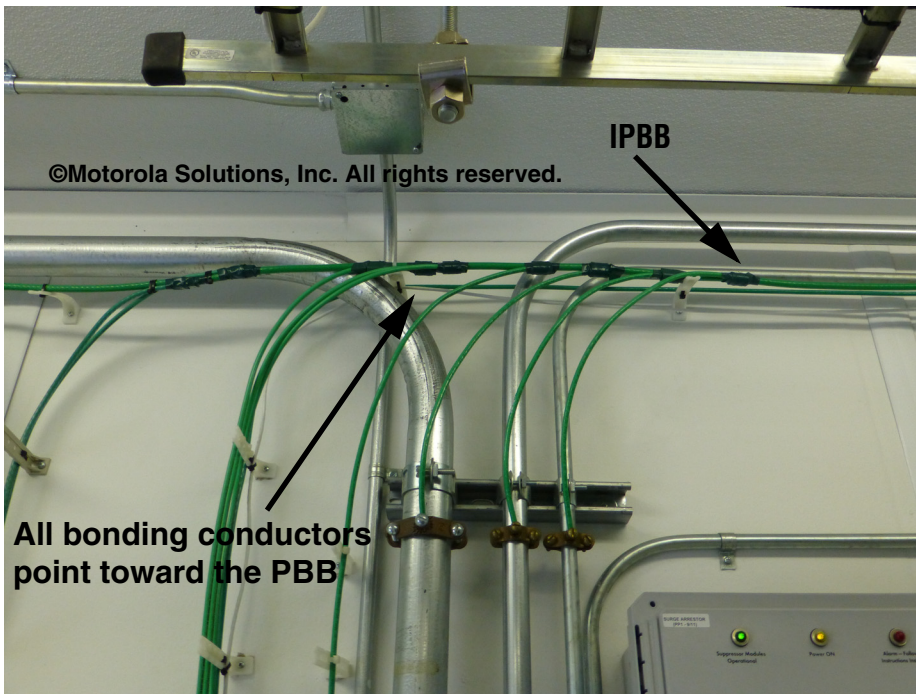

Figure 5-75 Bonding to the Internal Perimeter Bonding Bus (IPBB) Conductor

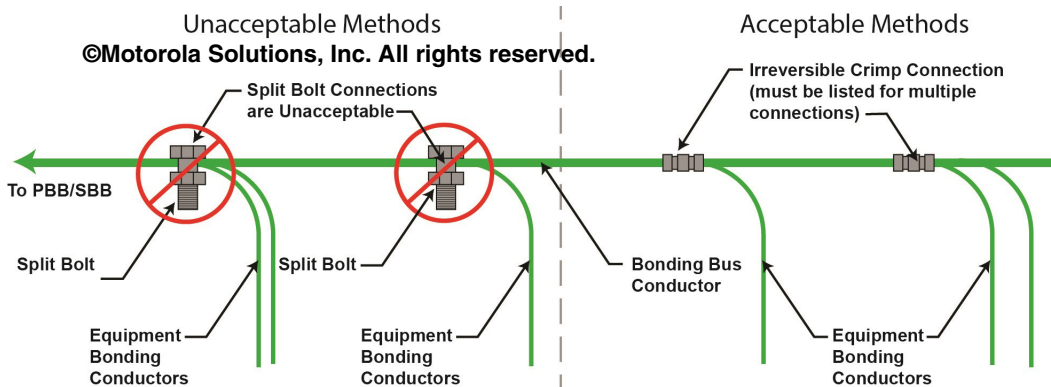

Figure 5-76 Acceptable and Unacceptable Methods for Bonding to Bonding Bus Conductor

5.8.11 Bonding to Bonding Backbone Conductors and Backbone Bonding Conductors

All applicable general bonding requirements and the requirements described in this section **shall** apply where attaching Secondary Bonding Bar (SBB) bonding conductors to a bonding backbone system.



NOTE

Equipment and ancillary apparatus are not normally bonded directly to a bonding backbone. This equipment should be bonded to a Secondary Bonding Bar (SBB) that bonds to the bonding backbone.

- All bonding backbone conductors should be installed without splices. Where splices are necessary, the number of splices should be kept to a minimum, and they **shall** be accessible and only located in telecommunication spaces. The joined segments **shall** be connected using exothermic welding or listed irreversible compression-type connectors. All bonding joints **shall** be adequately supported and protected from damage. See TIA-607-C.
- The bonding conductor between the SBB and the bonding backbone conductor **shall** be of the same specifications as the bonding backbone conductor.
- The bonding conductor between the SBB and the bonding backbone **shall** be continuous and routed in the shortest practicable straight line path towards the Primary Bonding Bar (PBB).
- The SBB bonding conductor **shall** be connected to the bonding backbone with exothermic welding or a listed irreversible compression-type connection (TIA-607-C).



IMPORTANT

Split bolt connection devices are not permitted.

5.9 Bonding Equipment to Internal Bonding and Grounding (Earthing) System

All equipment and ancillary support apparatus **shall** be bonded as described in this section and its subsections.

Table 5-8 provides methods of bonding to the internal bonding system from items (represented in Column 1) toward the PBB (earth) with the connection devices identified in this section.

- Column 1 represents the point of origin (opposite the PBB/earth) for the conductor represented in Column 2. The numbers in Column 1 represent the acceptable means of connecting the conductor represented in Column 2 to the point of origin listed in Column 1.

- The remaining columns represent the destination of the conductor described in Column 2. The numbers in those columns represent the acceptable means (if any) of connecting that conductor to the destination point listed in Column 2.

Bonding devices represented in column 1 of Table 5-8 are numbered as follows:

1. Single-hole lug
2. Two-hole lug
3. Irreversible high compression device
4. Exothermic welding
5. Clamping device
6. Manufacturer approved methods
7. Directly secured to bus bar



NOTE

Table 5-8 represents a typical installation. See the specific sections in this chapter for more details.



NOTE

Two-hole lugs are preferred over single-hole lugs and **shall** be used where practicable.



NOTE

Hardware and connection devices **shall** meet the requirements of “Connection Methods for Internal Bonding and Grounding (Earthing) System” on page 5-64.



NOTE

Metallic pathways and associated hardware under 1 m (3 ft) in length (for example, wall and floor sleeves, J-hooks, and so on) are not required to be bonded (TIA-607-C, section 7.1).

The following example shows the bonding of an SBB to a PBB:

1. Locate “SBB” in Column 1.
2. Column 1 indicates that the acceptable means of bonding the conductor represented in Column 2 are device 2 (two-hole lug), device 3 (irreversible high compression device) and device 4 (exothermic weld).
3. Column 2 indicates the minimum size bonding conductor required.
4. Cross reference the PBB column and notice that the acceptable means to connect that conductor to the PBB are devices 2, 3 and 4.

Table 5-8 BONDING TO THE INTERNAL BONDING SYSTEM FROM ITEM TOWARD EARTH - WITH CONNECTION METHODS IDENTIFIED

From Item	Minimum Conductor Size Unless Otherwise Specified (conductor to be sized according to length as described in this chapter)	Toward Earth					
		Rack Bonding Bar (RBB)	Bonding Bus Conductor	Bonding Grid	Internal Perimeter Bonding Bus (IPBB)	Secondary Bonding Bar (SBB)	Primary Bonding Bar (PBB)
SBB (2, 3, 4)	35 mm ² csa (#2 AWG)	-	3, 4	3, 4	-	2, 3, 4	2, 3, 4
RBB (2, 6)	35 mm ² csa (#2 AWG)	-	3, 4	3, 4	-	2, 3, 4	2, 3, 4
NBB (1, 2, 3)	16 mm ² csa (#6 AWG)	1, 2, 3	3, 4	3, 4	-	-	-
Bonding bus conductor	35 mm ² csa (#2 AWG)	-	N/A	-	-	2, 3, 4	2, 3, 4
Bonding bus branch conductor	To be sized the same as the main bonding bus conductor	-	3, 4	-	-	-	-
Bonding grid (round conductor) (3, 4)	35 mm ² csa (#2 AWG)	-	3, 4	N/A	-	2, 3, 4	2, 3, 4
Bonding grid (copper strap) (4, 6)	35 mm ² csa (#2 AWG)	-	3, 4	N/A	-	2, 3, 4	2, 3, 4
IPBB	35 mm ² csa (#2 AWG)	-	-	-	N/A	2, 3, 4	2, 3, 4
Cable tray (2, 6)	16 mm ² csa (#6 AWG)	-	3, 4	3, 4	-	2, 3, 4	2, 3, 4
Equipment cabinet (1, 2, 6)	16 mm ² csa (#6 AWG)	1, 2	3, 4	3, 4	-	2, 3, 4	2, 3, 4
Equipment rack (1, 2, 6)	16 mm ² csa (#6 AWG)	1, 2	3, 4	3, 4	-	2, 3, 4	2, 3, 4

Table 5-8 BONDING TO THE INTERNAL BONDING SYSTEM FROM ITEM TOWARD EARTH - WITH CONNECTION METHODS IDENTIFIED (CONTINUED)

From Item	Minimum Conductor Size Unless Otherwise Specified (conductor to be sized according to length as described in this chapter)	Toward Earth					
		Rack Bonding Bar (RBB)	Bonding Bus Conductor	Bonding Grid	Internal Perimeter Bonding Bus (IPBB)	Secondary Bonding Bar (SBB)	Primary Bonding Bar (PBB)
Network operator electronic equipment and metallic furniture framework (1, 2, 6)	6 mm ² csa (#10 AWG) for lengths not exceeding 3 m (10 ft) 16 mm ² csa (#6 AWG) for lengths not exceeding 3.9 m (13 ft)	-	3, 4 (Connection to the SBB is preferred and is required where practicable)	-	-	2, 3, 4	-
Network operator position AC receptacle boxes and/or PDU (5, 6)	6 mm ² csa (#10 AWG) for lengths not exceeding 3 m (10 ft) 16 mm ² csa (#6 AWG) for lengths not exceeding 3.9 m (13 ft)	-	3, 4 (Connection to the SBB is preferred and is required where practicable)	-	-	2, 3, 4	-
Network operator position Surge Protective Devices (6)	6 mm ² csa (#10 AWG) for lengths not exceeding 3 m (10 ft) 16 mm ² csa (#6 AWG) for lengths not exceeding 3.9 m (13 ft)	-	3, 4 (Connection to the SBB is preferred and is required where practicable)	-	-	2, 3, 4, 7	-
Transmission line surge protective device (1, 2, 6, 7)	16 mm ² csa (#6 AWG)	-	-	-	-	2, 3, 4, 7	2, 3, 4, 7
Telco/Data primary surge suppressor (1, 2, 6, 7)	6 mm ² csa (#10 AWG) for single line device 16 mm ² csa (#6 AWG) for multiple line device	-	-	-	3, 4	2, 3, 4, 7	2, 3, 4, 7

Table 5-8 BONDING TO THE INTERNAL BONDING SYSTEM FROM ITEM TOWARD EARTH - WITH CONNECTION METHODS IDENTIFIED (CONTINUED)

From Item	Minimum Conductor Size Unless Otherwise Specified (conductor to be sized according to length as described in this chapter)	Toward Earth					
		Rack Bonding Bar (RBB)	Bonding Bus Conductor	Bonding Grid	Internal Perimeter Bonding Bus (IPBB)	Secondary Bonding Bar (SBB)	Primary Bonding Bar (PBB)
Telco/Data secondary surge suppressor (1, 2, 6, 7)	6 mm ² csa (#10 AWG) for single line device 16 mm ² csa (#6 AWG) for multiple line device	1, 2, 7	3, 4	-	-	2, 3, 4, 7	2, 3, 4, 7
DC power plant return bus bar or terminal (2, 6)	Sized according to "DC Power Systems" on page 5-89	-	-	-	-	2, 3, 4	2, 3, 4
Generator support frame (2, 4, 6)	16 mm ² csa (#6 AWG)	-	-	-	3, 4	2, 3, 4	2, 3, 4
Separately derived system (1, 2, 6)	Sized according to "Separately Derived AC Systems" on page 5-84	-	3, 4	-	3, 4	2, 3, 4	2, 3, 4
Cable outer metal shield (6)	16 mm ² csa (#6 AWG)	-	-	-	-	2, 3, 4	2, 3, 4
Ancillary support item or structural metal (1, 2, 3, 4, 5, 6)	16 mm ² csa (#6 AWG)	-	-	3, 4	3, 4	2, 3, 4	2, 3, 4
Suspended ceiling grid (1, 2, 5, 6)	16 mm ² csa (#6 AWG)	-	-	3, 4	3, 4	2, 3, 4	2, 3, 4
Raised floor support pedestal or stringer support (5, 6)	Bonded according to "Raised Computer Floor Bonding" on page 5-115	-	-	3, 4	-	2, 3, 4	2, 3, 4

5.9.1 Equipment and Ancillary Support Apparatus Bonding

All equipment and ancillary support apparatus including, but not limited to, that listed in Table 5-8, **shall** be effectively bonded to the internal bonding system with a minimum 16 mm² csa (#6 AWG) equipment bonding conductor unless otherwise specified herein. Bonding to the internal bonding system can be made to any of the following:

- Primary Bonding Bar (PBB) (see “Master Ground (Earth) Bus Bar or Primary Bonding Bar” on page 5-10)
- Secondary Bonding Bar (SBB) (see “Sub System Ground Bus Bar or Secondary Bonding Bar” on page 5-17)
- Rack Bonding Bar (RBB) (see “Rack Ground Bus Bar or Rack Bonding Bar” on page 5-27)
- Network-equipment Bonding Bar (NBB) (see “Network-Equipment Bonding Bar” on page 5-32)
- An equipment bonding bus conductor (see “Equipment Bonding Bus Conductor” on page 5-49)
- Internal Perimeter Bonding Bus (IPBB) (ancillary support equipment only) (see “Internal Perimeter Bonding Bus Conductor” on page 5-56)
- Bonding grid (see “Supplementary Bonding Network or Bonding Grid” on page 5-59)

All bonding and grounding **shall** be established as described in the following subsections:

- “Separately Derived AC Systems” on page 5-84
- “Generators (Internal)” on page 5-87
- “Generators (External)” on page 5-88
- “DC Power Systems” on page 5-89
- “Equipment” on page 5-99
- “Cabinets and Racks” on page 5-102
- “Cable Trays” on page 5-104
- “Ancillary Support Apparatus” on page 5-107
- “Metallic Building Structure and Piping Systems” on page 5-114
- “Raised Computer Floor Bonding” on page 5-115
- “Surge Protective Devices” on page 5-117

5.9.1.1 Separately Derived AC Systems

Separately derived systems are an electrical source, other than a service, having no direct connection(s) to circuit conductors of any other electrical source other than those established by grounding and bonding connections (NFPA 70-2017, Article 100). Separately derived AC electrical power systems have no direct electrical connection between the incoming neutral from the AC power source and the neutral conductor on the secondary side of the separately derived AC power system (see Figure 5-77, Figure 5-78 and Figure 5-79).

Separately derived power systems can include isolation transformers, step-down transformers, step-up transformers, generator AC power systems that break the neutral conductor inside the automatic transfer switch (ATS), Uninterruptible Power Supply (UPS) systems that are configured as separately derived systems or AC inverters that are powered by a battery bank.

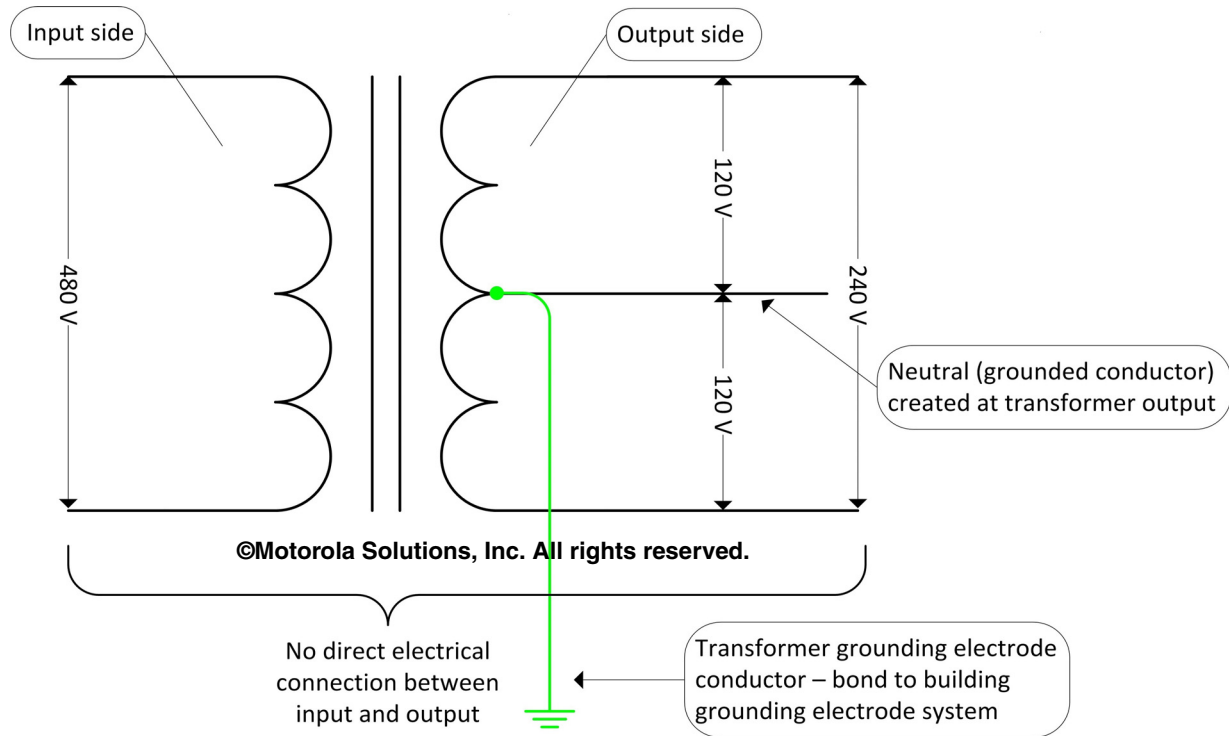

Figure 5-77 Example of Step-Down Transformer Schematic

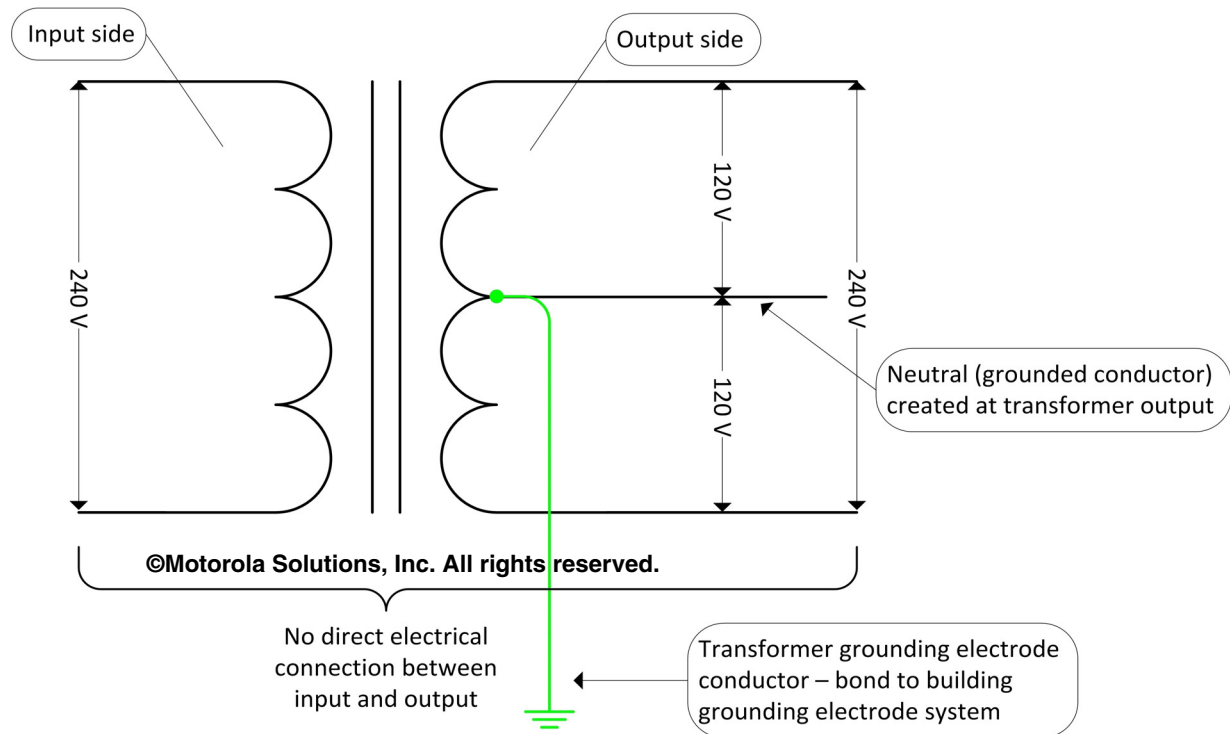

Figure 5-78 Example of Isolation Transformer Schematic



Figure 5-79 Example of Transformer

A rack mounted separately derived system may bond to a Rack Bonding Bar (RBB) if the bonding conductor feeding the RBB meets the sizing requirements of Table 5-9, or a separate bonding conductor may be installed. As applicable, the conductor feeding the RBB **shall** also meet the requirements of “Racks, Cabinets and Equipment Supplied from DC Systems” on page 5-94.

Table 5-9 GROUNDING ELECTRODE CONDUCTOR SIZING FOR SEPARATELY DERIVED SYSTEMS

Size of Ungrounded Conductor		Size of Grounding Electrode Conductor	
in csa	in AWG	in csa	in AWG
50 mm ² or less	1/0 or less	16 mm ²	6
70 mm ²	2/0	25 mm ²	4
95 mm ²	3/0	25 mm ²	4
greater than 95 mm ² to 177.39 mm ²	greater than 3/0 to 350 kcmil	35 mm ²	2
greater than 177.93 mm ² to 304.025 mm ²	greater than 350 kcmil to 600 kcmil	50 mm ²	1/0
greater than 304.025 mm ² to 557.4 mm ²	greater than 600 kcmil to 1100 kcmil	70 mm ²	2/0
greater than 557.4 mm ²	greater than 1100 kcmil	95 mm ²	3/0

Derived from NFPA 70-2017, Table 250.66 and other industry standards.



NOTE

A rack supplied DC from a 200 A source would require a minimum 16 mm² csa (#6 AWG) bonding conductor, based on a maximum conductor length of 4m (13 ft). See Table 5-3 and Table 5-10 for more information.

5.9.1.1.1 Transformers, Inverters and UPS Systems (Containing Isolation Transformer)

If a separately derived AC power system exists at the site, a grounding electrode conductor at the neutral-to-ground bond on the secondary side of the unit **shall** be bonded to the nearest practicable location of the internal bonding and grounding system (for example, Primary Bonding Bar, Secondary Bonding Bar, bonding backbone conductor or structural building metal) with a 16 mm² csa (#6 AWG) or larger, green-jacketed grounding conductor. The grounding conductor **shall** also be sized according to Table 5-9 (see NFPA 70-2017, Article 250.66 for more information). The connection **shall** be made according to manufacturer requirements.

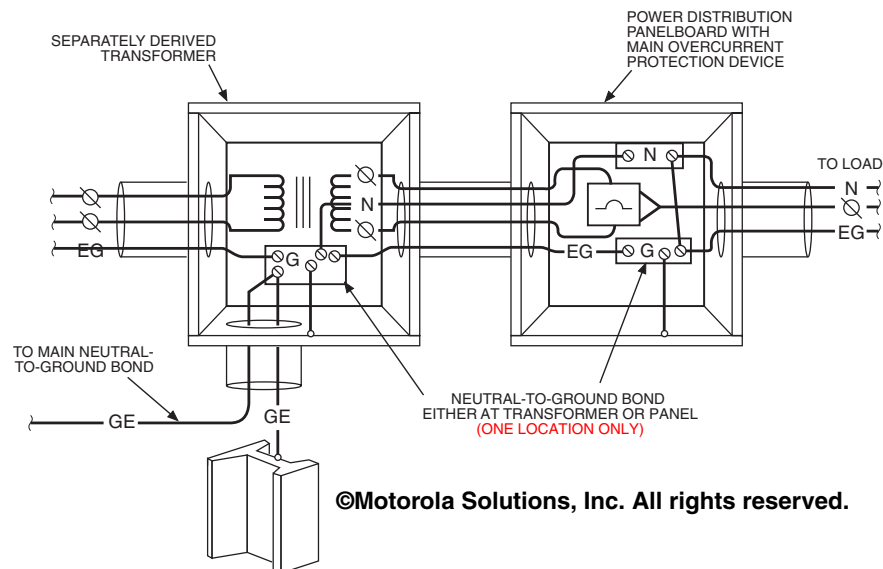

Figure 5-80 Grounding of a Dry Type Isolation Transformer

5.9.1.2 Generators (Internal)

If a generator is configured as a separately derived system (the Automatic Transfer Switch (ATS) breaks the neutral upon switching), a grounding electrode conductor at the neutral-to-ground bond in the generator **shall** be bonded to the nearest location of the internal bonding and grounding system (for example, Primary Bonding Bar or Secondary Bonding Bar) with a 16 mm² csa (#6 AWG) or larger, green-jacketed grounding conductor (see Figure 5-81). The grounding conductor **shall** also be sized according to Table 5-9 (see NFPA 70-2017, Article 250.66 for more information).

Figure 5-82 shows an example of a transfer switch that does not break the neutral; therefore, is not a separately derived system.



IMPORTANT

Generators are often shipped from the factory with a neutral-to-ground bond established within the generator unit. If the generator Automatic Transfer Switch (ATS) is not configured for a separately derived system, this factory-installed bonding conductor must be removed.



NOTE

If an ATS is configured for a separately derived system, the neutral (grounded) conductor will be switched (see Figure 5-81).

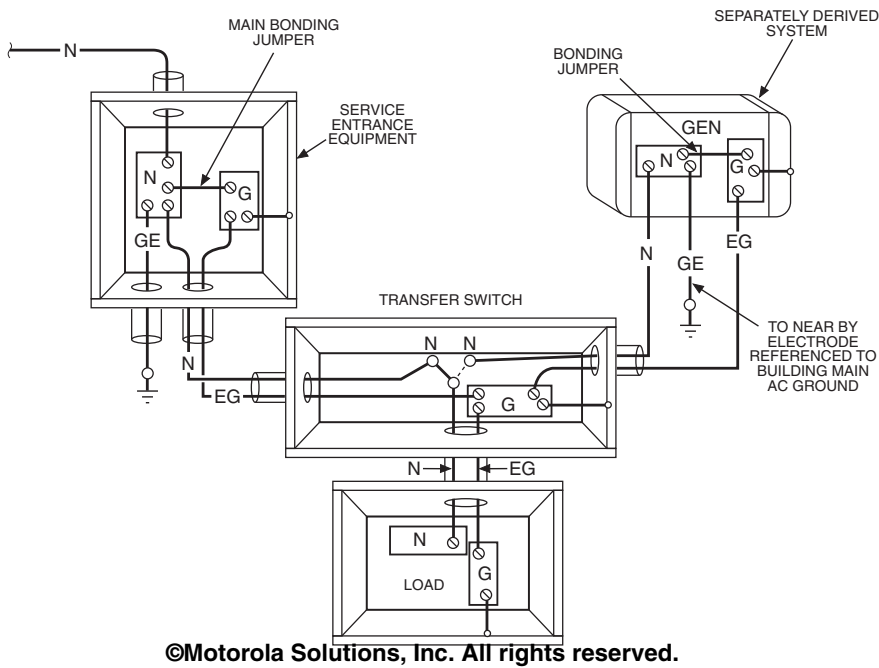

Figure 5-81 Generator System with Switched Neutral

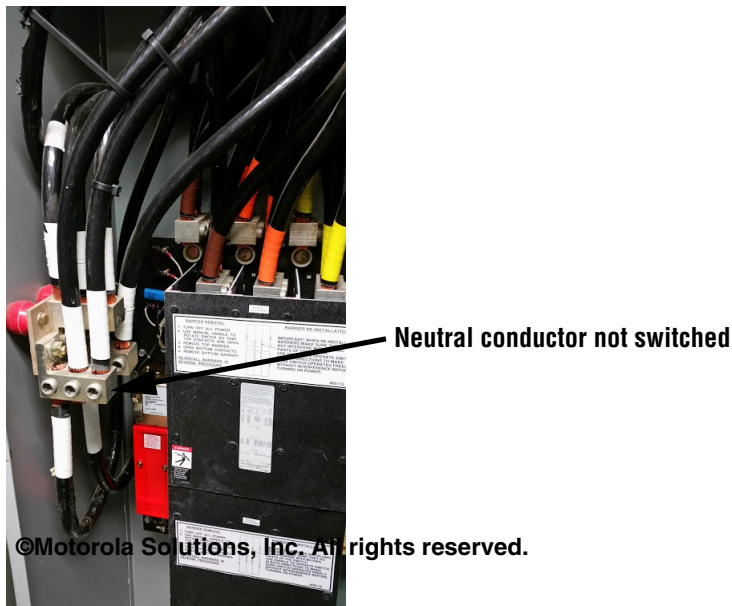

Figure 5-82 Generator Transfer Switch - Neutral Not Switched

5.9.1.3 Generators (External)

See Chapter 4, “External Grounding (Earthing) and Bonding”, for bonding and grounding requirements.

5.9.1.4 DC Power Systems

A DC power system is normally installed in a separate cabinet or rack and is typically equipped with storage batteries for reserve output power during a utility failure. Depending upon the types of communications equipment being powered, the power system can be configured as a two-wire or three-wire system.



IMPORTANT

The proper bonding and grounding of a DC power system may require the assistance from an engineer and/or certified R56 Auditor Subject Matter Expert (SME).



IMPORTANT

For optimum bonding and grounding, the DC power system should be installed as close as practicable to the Primary Bonding Bar (PBB). If a DC power system is installed beyond 30.5 m (100 ft) from the PBB, the DC power system bonding and grounding requirements should be specified by an engineer and/or certified R56 Auditor SME.

A DC power system typically consists of six major segments by equipment function (see Figure 5-83) (ATIS-0600311.2007):

- Rectifier/chargers
- Storage batteries
- Charge bus
- Discharge bus
- Primary power distribution
- Secondary Power Distribution Unit (PDU)

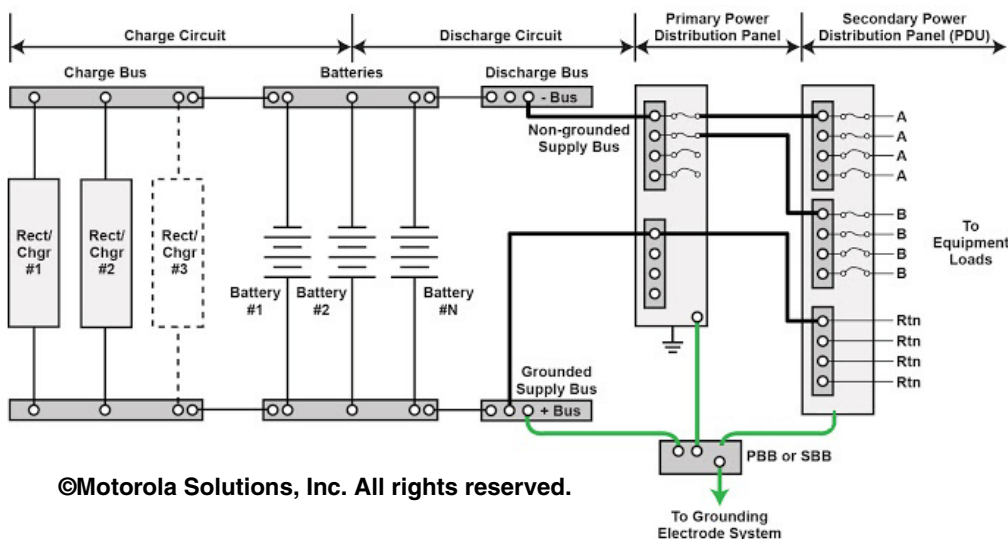

Figure 5-83 Typical Wiring Details for Isolated Ground-Type System (-48V System Example)



NOTE

Individual DC power supplies for control stations and similar devices are not considered DC power systems as long as their wiring is not used in a premises wiring system (for example, distributed in a cable tray system).

Where a DC power system is installed at a communications site, it **shall** meet the following bonding and grounding requirements:

- DC power systems **shall** comply with grounding and bonding requirements of NFPA 70-2017, Part VIII, and other sections of Article 250 not specifically intended for AC systems (NFPA 70-2017, Article 250.160).
- Grounding of the electrical power system and bonding of surge protective devices and normally non-current-carrying metal parts of equipment **shall** be installed and arranged in a manner that will prevent objectionable current (NFPA 70-2017, Article 250.6).
- If a DC power system is required to be installed as a grounded system, an isolated ground-type system **shall** be installed to help prevent objectionable current. See installation requirements in “Installation Requirements for Isolated Ground-Type System” on page 5-90.
- Bonding **shall not** depend on incidental paths through equipment racks, cabinets, cable trays or other conductive surfaces (see ATIS-0600311.2007, section 6.1, for additional information).
- Frames, cabinets, racks and so on **shall** be bonded and grounded according to “Frames, Cabinets and Racks as Part of DC Systems” on page 5-93.

The following types of DC power systems **shall** be installed as grounded systems:

- A two-wire, DC system supplying premises wiring and operating at greater than 60 volts but not greater than 300 volts (NFPA 70-2017, Article 250.162(A)).
- All three-wire, DC systems supplying premises wiring (NFPA 70-2017, Article 250.162(B)).
- A DC system with an output exceeding 150 W (ATIS-0600333.2013, section 7.1). This applies to all battery systems, converter systems, and all converters installed in equipment frames, cabinets or other enclosures, whether or not the DC source serves loads located in the same enclosure.

5.9.1.4.1 Installation Requirements for Isolated Ground-Type System

To help prevent objectionable current, the DC power system **shall** be bonded to the facility single point bonding location in an isolated ground-type system configuration. In an isolated ground-type system, the DC power system return conductors are only bonded to the internal bonding system at one point. In this configuration and under normal operating conditions, the internal bonding and grounding system does not carry DC current. Any DC current on the internal bonding and grounding system will be the result of one or more of the following: a fault condition, incorrectly configured equipment (for example, not configured for isolated grounding), improperly installed equipment and so on. See ATIS-0600311.2007 and ATIS-0600333.2013 for additional information.

The following requirements **shall** be met for establishing an isolated ground-type system for the DC power system:

- A Primary Bonding Bar **shall** be installed at the site according to “Master Ground (Earth) Bus Bar or Primary Bonding Bar” on page 5-10.
- If the DC Power System is installed in a separate room away from the Master Ground Busbar (MGB) or Primary Bonding Bar (PBB), a Secondary Bonding Bar (SBB) **shall** be installed in the DC Power System room according to “Sub System Ground Bus Bar or Secondary Bonding Bar” on page 5-17.
 - The bonding conductor between the SBB and PBB **shall** be sized according to “Sizing of SBB-to-PBB Conductor Where Part of a DC System” on page 5-98.
- All DC powered equipment (for example, racks of base station repeaters and associated equipment) **shall** be bonded to the internal bonding and grounding system (for example, PBB, SBB, RBB or equipment bonding bus conductor) as described in this chapter.
- The DC power system main return bus bar or the primary distribution panel main return bus terminal (one or the other) **shall** be bonded to the facility’s single point bonding location (see Figure 5-84 and Figure 5-85).
 - The single point bonding location **shall** be the facility’s Primary Bonding Bar (PBB) or a designated Secondary Bonding Bar (SBB) that serves as the single point bonding bar for a separate location.

**NOTE**

The conductor used to bond the DC system main return bus or primary distribution panel main return bus bar/terminal to the facility's single point bonding location becomes the DC System Bonding Jumper (see NFPA 70-2017, Article 250.168).

**IMPORTANT**

The DC power system shall be bonded to the internal bonding and grounding system at only one location. Bonding at more than one location will cause objectionable DC current to flow on the internal bonding and grounding system.

**IMPORTANT**

Where a DC power system is installed, the internal bonding and grounding system shall be tested for objectionable DC current after all equipment is installed. See “DC Current Testing” on page 5-141 for testing details.

- The DC return bus conductor (DC system bonding jumper) **shall** only be used to bond the DC power system. This conductor **shall not** be used for bonding other equipment.
- Where a secondary Power Distribution Unit (PDU) is installed, the return bus conductors **shall** be insulated from the PDU enclosure and supporting framework of the cabinet or rack. This is to prevent objectionable DC current.
- The DC power plant grounding/bonding conductor **shall** be bonded to both bus bars with an irreversible compression-type two-hole listed lug as described within this chapter.

The following equipment installation requirements **shall** be met for an isolated ground-type system:

- All supplied equipment and components **shall** be approved for use in an isolated ground-type system. Third-party certified equipment and components **shall** be listed for the purpose (ATIS-0600311.2007, section 7.2).
- Where a DC-to-DC converter is installed, the unit's return bus conductors **shall** be insulated from the unit's enclosure and the supporting framework of the cabinet or rack. This is to prevent objectionable DC current.
- If a DC-to-DC converter's rated output exceeds 150 Watts, it **shall** be installed as a grounded system (ATIS-0600333.2013, section 7.1).
 - All installation requirements for an isolated ground-type system **shall** apply.
 - A rack mounted unit may bond to a Rack Bonding Bar (RBB) if the bonding conductor feeding the RBB meets the sizing requirements of “Sizing of DC System Bonding Jumper” on page 5-95, or a separate bonding conductor may be installed.
 - A unit may be bonded to the bonding backbone system or to an equipment bonding bus conductor if the conductor meets the sizing requirements of “Sizing of DC System Bonding Jumper” on page 5-95, or a separate bonding conductor may be installed.
- If a DC-to-AC inverter is installed, it **shall** be installed as a grounded system by following the requirements of “Separately Derived AC Systems” on page 5-84.

See Figure 5-84 for an example of bonding the DC return bus in an isolated ground-type system.

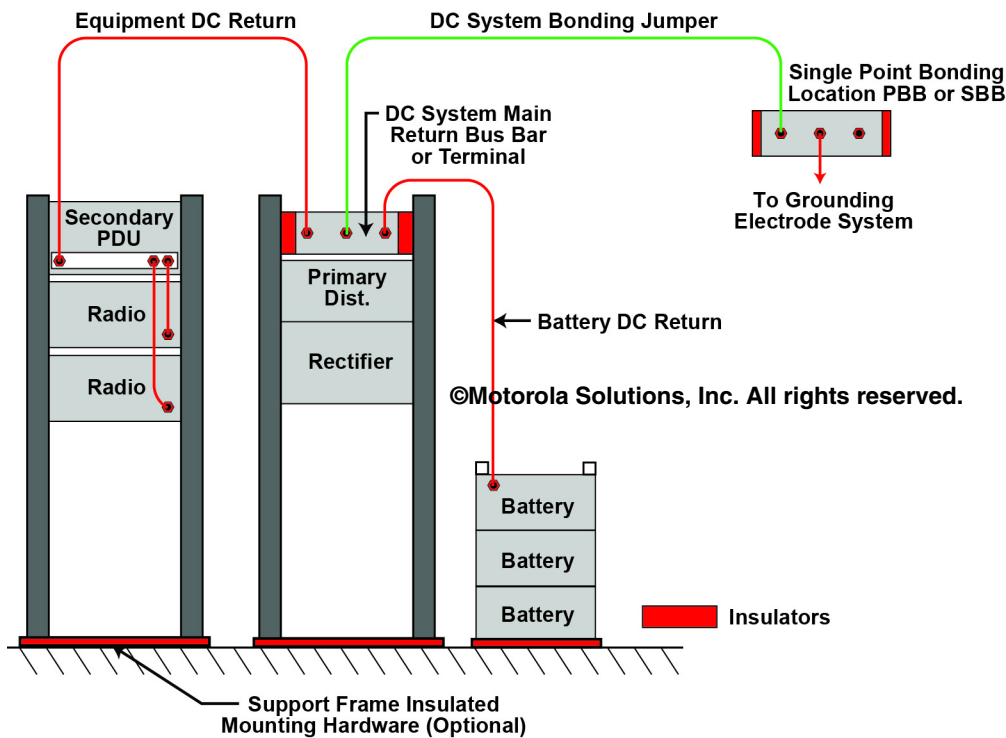

Figure 5-84 Bonding of DC Return Bus in Isolated Ground-type System

5.9.1.4.2 DC Return Bonding Conductor

The DC return bonding conductor is the conductor that bonds the DC system return bus to the site's internal bonding and grounding system (PBB or SBB) and to the site's grounding electrode system. The DC return bonding conductor may be referred to as the DC System Bonding Jumper (see NFPA 70-2017, Article 250.168).

The DC return bonding conductor **shall** be minimally sized according to "Sizing of DC System Bonding Jumper" on page 5-95.



IMPORTANT

The DC return bonding conductor/jumper shall not contain a splice (NFPA 70-2017, Article 250.168).



NOTE

It is a common practice to size the DC return bonding conductor the same as the largest current-carrying conductor in the DC system.

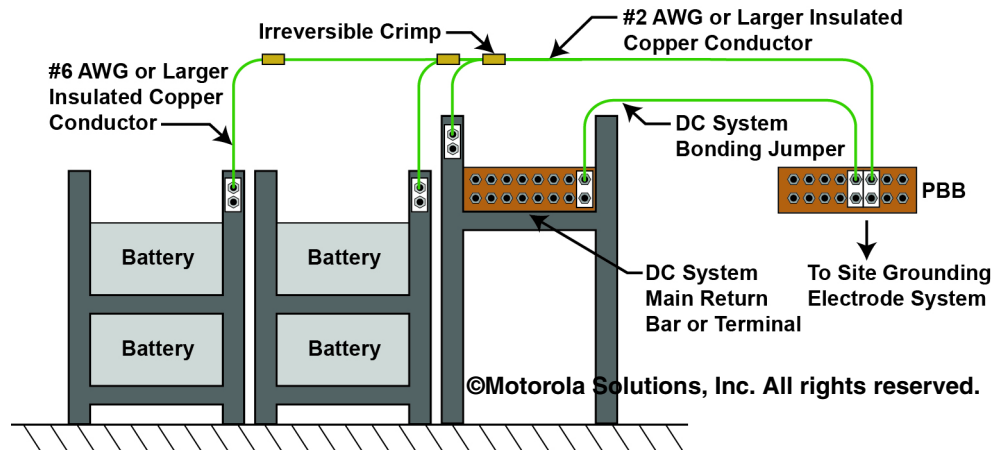

Figure 5-85 DC Power Plant and Frame Grounding

5.9.1.4.3 Battery Racks

Metallic battery racks or enclosures **shall** be bonded with a minimum 16 mm² csa (#6 AWG) conductor (see ATIS-0600311-2007, section 6.3.5) and **shall** meet the size requirements of “Equipment Bonding Conductor Specifications” on page 5-46.” A minimum 35 mm² csa (#2 AWG) bonding conductor is recommended (see FAA 019e, section 4.2.10.5(c)).



NOTE

A 16 mm² csa (#6 AWG) conductor **shall** be increased in size if the conductor length exceeds 4 m (13 ft). See Table 5-4 for more information.

5.9.1.4.4 Cable Tray Systems Supporting DC Conductors

Cable tray systems that support DC conductors **shall** be bonded according to “Cable Trays” on page 5-104. In addition, the bonding conductor(s) **shall** be minimally sized the same as the DC return bonding conductor (see “DC Return Bonding Conductor” on page 5-92). See “Cable Tray Installation Requirements” on page 9-36 for DC power conductor cable tray installation requirements.



NOTE

This section applies to the cable tray bonding conductor and to bonding jumpers for cable tray sections that contain DC conductors.



NOTE

Cable trays that are listed as a suitable equipment grounding conductor are recommended where the cable tray supports DC cabling. See “Cable Trays” on page 5-104 and Figure 5-96.

5.9.1.4.5 Frames, Cabinets and Racks as Part of DC Systems

Exposed normally non-current carrying metal parts of fixed equipment supplied by, enclosing or supporting electrical conductors or components that are likely to become energized **shall** be bonded as necessary to ensure electrical continuity and capacity to safely conduct any fault current likely to be imposed on them (see NFPA 70-2017, Articles 250.4(A), 250.96, 250.102, 250.110 and 250.122).

All frames, cabinets, racks and other metallic enclosures as part of a DC system **shall** be bonded according to all of the following:

- All frames, cabinets, racks and other metallic enclosures of a DC power system **shall** be bonded to the Primary Bonding Bar (PBB) or Secondary Bonding Bar (SBB) as described in “Cabinets and Racks” on page 5-102 (see ATIS-0600333.2013, section 7.2).
- The bonding conductor(s) **shall** be minimally sized based on the size of the overcurrent protection device according to “Sizing of DC System Bonding Jumper” on page 5-95.
- The bonding conductor(s) **shall** also be minimally sized based on conductor length according to Table 5-4.



NOTE

A bus conductor may be used for bonding all equipment (see Figure 5-86). The bus conductor **shall** be sized according to the largest conductor required.

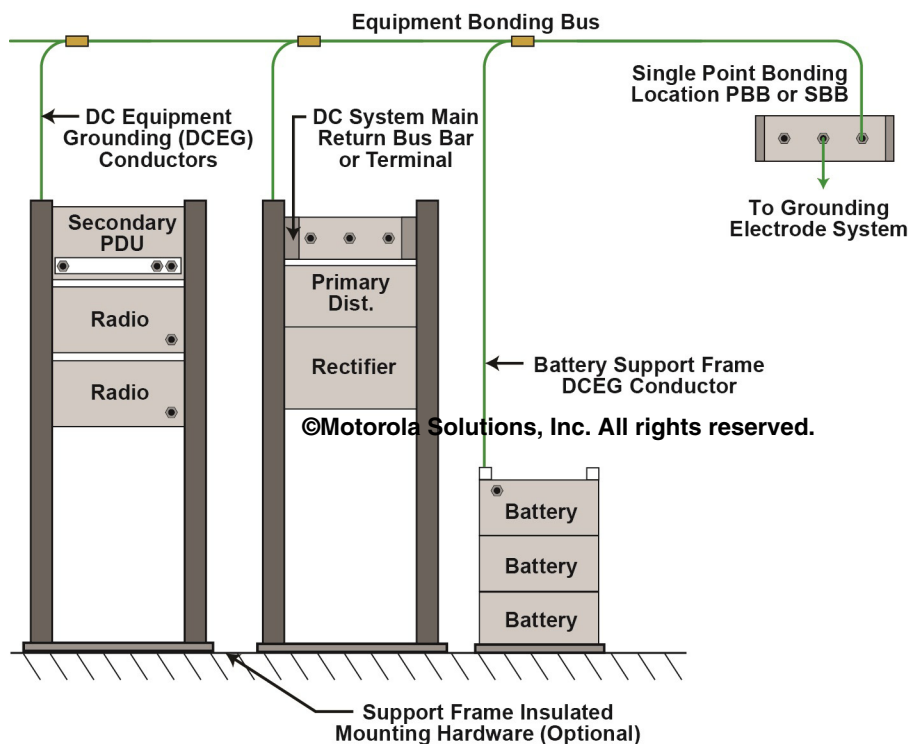

Figure 5-86 Bonding of Rack Supporting Framework

5.9.1.4.5.1. Racks, Cabinets and Equipment Supplied from DC Systems

Racks and cabinets supplied with power from a DC system are bonded in a manner similar to that described in “Frames, Cabinets and Racks as Part of DC Systems” on page 5-93. Racks and cabinets supplied with power from a DC system **shall** be bonded according to all of the following:

- All racks and cabinets supplied with power from a DC system **shall** be bonded to the Primary Bonding Bar (PBB) or Secondary Bonding Bar (SBB) as described in “Cabinets and Racks” on page 5-102 (see ATIS-0600333.2013, section 7.2).
- The bonding conductor(s) **shall** be minimally sized based on the size of the upstream overcurrent protection device according to “Sizing of DC System Bonding Jumper” on page 5-95.
- The bonding conductor(s) **shall** also be minimally sized based on conductor length according to Table 5-4.

**NOTE**

A rack supplied DC from a 200 A source would require a minimum 16 mm² csa (#6 AWG) bonding conductor, based on a maximum conductor length of 4m (13 ft). See Table 5-4 and Table 5-10 for more information.

5.9.1.4.5.2. DC Powered Equipment Installed in Rack

DC powered equipment installed in a rack is bonded in a manner similar to that described for racks and cabinets supplied with power from a DC system (see “Racks, Cabinets and Equipment Supplied from DC Systems” on page 5-94). DC powered equipment installed in a rack **shall** be bonded according to all of the following:

- DC powered equipment installed in a rack **shall** be bonded according to “Equipment” on page 5-99.
- The bonding conductor(s) **shall** be minimally sized according to “Sizing of DC System Bonding Jumper” on page 5-95, based on the upstream overcurrent device of the DC conductors feeding the equipment from the Power Distribution Unit (PDU).
- The bonding conductor(s) **shall** also be minimally sized based on conductor length according to Table 5-4.

**NOTE**

DC powered equipment installed in a rack is typically bonded to a Rack Bonding Bar (RBB). The RBB bonding conductor **shall** be sized the same as that described in “Racks, Cabinets and Equipment Supplied from DC Systems” on page 5-94.

**NOTE**

A 16 mm² csa (#6 AWG) equipment bonding conductor is adequate for a DC supply up to 200A, based on a maximum conductor length of 4m (13 ft). See Table 5-4 and Table 5-10 for more information.

5.9.1.4.6 Sizing of DC System Bonding Jumper

All DC bonding and grounding conductors **shall** meet the requirements of “Bonding and Grounding (Earthing) Conductors” on page 5-39. The DC system bonding jumper **shall** be sized according to all of the following:

**IMPORTANT**

An engineer and/or certified R56 Auditor Subject Matter Expert (SME) should be consulted for calculating the size of the DC System Bonding Jumper.

**NOTE**

DC bonding conductors should be sized for the largest possible expansion of the DC power system at the time of installation.

1. The minimum size DC system bonding jumper **shall** be 16 mm² csa (#6 AWG) (ATIS-0600311.2007 and ATIS-0600333.2013).
2. DC system bonding jumpers **shall** be minimally sized according to Table 5-10, based on the largest overcurrent protective device in the circuit ahead of the equipment unless otherwise specified within this chapter (see ATIS-0600311.2007 and ATIS-0600333.2013 for additional information).
3. If the conductor length is less than or equal to the maximum distance shown in Table 5-10 for the appropriate system voltage, use the listed conductor size. If the conductor length is longer, go to step 4.

Table 5-10 MINIMUM SIZE DC SYSTEM BONDING JUMPER

Overcurrent Protection Device Rating	Minimum Bonding Conductor Size	Maximum Distance (Rounded Down to Nearest 0.5 ft or 0.25 m) Before Conductor Must Be Increased in Size		
		12 V System	24 V System	48 V System
200 A or less	16 mm ² csa (6 AWG)	4 m (13 ft)	8 m (26 ft)	16 m (52.5 ft)
300 A	25 mm ² csa (4 AWG)	4.25 m (13.5 ft)	8.5 m (27.5 ft)	17 m (55.5 ft)
400 A	35 mm ² csa (3 AWG)	4 m (13 ft)	8 m (26 ft)	16 m (52.5 ft)
500 A	35 mm ² csa (2 AWG)	4 m (13 ft)	8 m (26.5 ft)	16.25 m (53 ft)
600 A	50 mm ² csa (1 AWG)	4.25 m (13.5 ft)	8.5 m (27.5 ft)	17 m (55.5 ft)
800 A	70 mm ² csa (1/0 AWG)	4 m (13 ft)	8 m (26 ft)	16 m (52.5 ft)
1000 A	70 mm ² csa (2/0 AWG)	4 m (13 ft)	8 m (26 ft)	16 m (52.5 ft)
1200 A	95 mm ² csa (3/0 AWG)	4.25 m (14 ft)	8.5 m (28 ft)	16.75 m (55 ft)
1600 A	120 mm ² csa (4/0 AWG)	4 m (13 ft)	8 m (26 ft)	16 m (52.5 ft)
2000 A	150 mm ² csa (250 kcmil)	3.75 m (12.5 ft)	7.5 m (25 ft)	15 m (50 ft)
Sources:				
<ul style="list-style-type: none"> • NFPA 70-2017, Table 250.122 • ATIS-0600311.2007 				

4. The DC system bonding jumper **shall** also be sized according to the allowable resistance of the fault current path (see ATIS-0600311.2007 and ATIS-0600333.2013). The DC system bonding jumper **shall** be sized to yield a voltage drop equal to or less than 90% of the nominal source voltage while carrying a fault current equal to a minimum of 10 times the rating of the largest overcurrent device.

The following formula is used (see Table 5-11):

$$R_{max} = (0.9 \times V_{nom}) / (10 I_{opd})$$

Where:

- R_{max} = Maximum resistance of envisaged fault current path
- V_{nom} = Nominal source voltage (V)
- I_{opd} = Current rating of overcurrent protection device

Table 5-11 provides the R_{max} values for common overcurrent protection device ratings and system voltages.

Consider the following example:

- $V_{nom} = -48$ V
- $I_{opd} = 300$ A
- Conductor length = 100 ft (30.48 m)

Considering the current rating of the upstream overcurrent protection device (300 A), Table 5-10 initially indicates

that the minimum size conductor is 25 mm² csa (# 4 AWG), but only for a conductor length up to 55.5 ft (17 m). Based on the 100 ft (30.48 m) conductor length in this example, Step 4 is now required.

The purpose of Step 4 is to calculate the maximum allowable fault current resistance (R_{max}) (see Table 5-11 for completed R_{max} calculations for the different voltage systems):

$$R_{max} = (0.9 \times 48) / (10 \times 300) = 0.0144\Omega$$

A maximum resistance of 0.0144Ω for 100 feet of conductor corresponds to 0.000144Ω (or 0.144mΩ) per conductor foot.

Table 5-11 R_{MAX} CALCULATED VALUES (Ω)

Overcurrent Protection Device Rating	R_{max}		
	12 V	24 V	48 V
200 A or less	0.0054 Ω	0.0108 Ω	0.0216 Ω
300 A	0.0036 Ω	0.0072 Ω	0.0144 Ω
400 A	0.0027 Ω	0.0054 Ω	0.0108 Ω
500 A	0.00216 Ω	0.00432 Ω	0.00864 Ω
600 A	0.0081 Ω	0.0036 Ω	0.0072 Ω
800 A	0.00135 Ω	0.0027 Ω	0.0054 Ω
1200 A	0.0009 Ω	0.0018 Ω	0.0036 Ω
1600 A	0.000675 Ω	0.00135 Ω	0.0027 Ω
2000 A	0.000675 Ω	0.00135 Ω	0.0027 Ω

Resistance per conductor foot =

$$(R_{max} / \text{Conductor Length (ft)}) = (0.0144\Omega / 100) = 0.000144\Omega$$

A conductor size with a maximum resistance of 0.000144Ω/ft (or 0.144 mΩ/ft) is required. From Table 5-12, a 50 mm² csa (# 1 AWG) conductor is the closest match.



NOTE

A mΩ equals 1/1000th of an ohm (Ω).

Table 5-12 RESISTANCE OF COPPER CONDUCTOR

Bonding Conductor Size	Resistance
16 mm ² csa (6 AWG)	0.411 mΩ/ft
25 mm ² csa (4 AWG)	0.258 mΩ/ft
35 mm ² csa (3 AWG)	0.205 mΩ/ft
Source: ATIS-0600333.2013, Table D.2	

Table 5-12 RESISTANCE OF COPPER CONDUCTOR (CONTINUED)

Bonding Conductor Size	Resistance
35 mm ² csa (2 AWG)	0.162 mΩ/ft
50 mm ² csa (1 AWG)	0.129 mΩ/ft
70 mm ² csa (1/0 AWG)	0.102 mΩ/ft
70 mm ² csa (2/0 AWG)	0.081 mΩ/ft
95 mm ² csa (3/0 AWG)	0.0642 mΩ/ft
120 mm ² csa (4/0 AWG)	0.051 mΩ/ft
150 mm ² csa (250 kcmil)	0.0431 mΩ/ft
185 mm ² csa (350 kcmil)	0.031 mΩ/ft
240 mm ² csa (500 kcmil)	0.021 mΩ/ft
400 mm ² csa (750 kcmil)	0.0144 mΩ/ft
Source: ATIS-0600333.2013, Table D.2	

5.9.1.4.6.1. Sizing of SBB-to-PBB Conductor Where Part of a DC System

Where a DC power system is bonded to a Secondary Bonding Bar (SBB), the SBB to Primary Bonding Bar (PBB) conductor (or bonding backbone conductor) **shall** be appropriately sized for the DC power system, as follows (ATIS-0600333.2013, section 9.1.4):

- The conductor **shall** be at least 50 mm² csa (1/0 AWG).
- The conductor **shall** be sized at 6561 circular mils per linear meter (2000 circular mils per linear foot), according to Table 5-3 (see TIA-607-C, Table 1).
 - The conductor is not required to be larger than 400 mm² csa (750 kcmil).

If structural metal (a metal frame or framework) is used as the bonding backbone conductor or PBB-to-SBB bonding conductor, the SBB **shall** bond to the structural metal (the metal frame or framework) using a bonding conductor minimally sized the same as the DC system bonding jumper (see “Sizing of DC System Bonding Jumper” on page 5-95).

Before utilizing structural metal, building plans (including as-builts as applicable) and specifications **shall** be reviewed to ensure the structural metal is electrically continuous or can be made so (TIA-607-C, section 6.3.5.1). Additionally, the two point continuity test (see TIA-607-C, section 9.1) or equivalent, should be performed on the structural metal to verify electrical continuity and acceptable resistance along the paths used as bonding conductors (TIA-607-C, section 6.3.5.1).

5.9.1.4.6.2. DC System Grounding Electrode Conductor

Where the DC power system is installed in a standard communications-type building or shelter, the DC system grounding electrode conductor requirements are met where a Primary Bonding Bar (PBB) is installed according to “Master Ground (Earth) Bus Bar or Primary Bonding Bar” on page 5-10 and the associated subsections. See NFPA 70-2017, Article 250.166 for more information.

Where the DC power system is installed in a larger and/or multi-story building that contains a bonding backbone (see “Bonding Backbone and Bonding Backbone Conductor” on page 5-53 and associated subsections), the PBB **shall** bond to the electrical service equipment (power) ground using a conductor of the same size or larger, as the bonding backbone conductor (TIA-607-C, section 5.2.3). See “Bonding Backbone and Bonding Backbone Conductor” on page 5-53.

5.9.1.5 Equipment

An equipment bonding conductor **shall** be attached to the equipment bonding/grounding terminal, chassis or frame utilizing methods described within this chapter. On equipment where a ground stud or connection point is provided by the manufacturer and this ground stud or connection point is sized and/or located so that a 16 mm² csa (#6 AWG) conductor cannot be reasonably attached, the 16 mm² csa (#6 AWG) equipment bonding conductor **shall** be attached to the equipment mounting screw or other suitable attachment point.

Where a terminal strip or other type connection point is an integral part of the equipment (for example, a PC board terminal) and this connection point must be connected to ground, a jumper sized per the manufacturer's instructions **shall** be installed between this point and the equipment bonding conductor. Manufacturer's installation instructions regarding bonding and grounding **shall** be followed in all instances unless the manufacturer specifies a bonding/grounding conductor smaller than 16 mm² csa (#6 AWG); in these cases a 16 mm² csa (#6 AWG) equipment bonding conductor **shall** be used. If the manufacturer has not provided specific bonding and grounding instructions for their equipment, the instructions contained within this paragraph **shall** prevail.



NOTE

See “Equipotential Grounding (Earthing) of the Network Operator Position” on page 5-134 for specific exceptions to the 16 mm² csa (#6 AWG) equipment bonding conductor requirement.

Bonding can be made to any of the following:

- Rack Bonding Bar (RBB). See “Rack Ground Bus Bar or Rack Bonding Bar” on page 5-27.
- Secondary Bonding Bar (SBB). See “Sub System Ground Bus Bar or Secondary Bonding Bar” on page 5-17.
- Primary Bonding Bar (PBB). See “Master Ground (Earth) Bus Bar or Primary Bonding Bar” on page 5-10.
- Bonding grid (see “Supplementary Bonding Network or Bonding Grid” on page 5-59)
- An equipment bonding bus conductor. See “Equipment Bonding Bus Conductor” on page 5-49.

Manufacturer's installation instructions (if available) **shall** be followed when bonding to equipment. Two-hole lugs **shall** be used over single hole lugs where practicable.



IMPORTANT

Electronic equipment shall not bond to the Internal Perimeter Bonding Bus (IPBB) conductor. Only ancillary equipment shall bond to the IPBB.



NOTE

Grounding of communication equipment through the Alternating Current (AC) power cord does not meet the intent of this installation standard and other related industry standards. While the AC power cord typically contains an Equipment Grounding Conductor (EGC), the integrity of the electrical distribution system EGC ground path to the electrical service (power) ground cannot be easily verified (see TIA-607-C and IEEE 1100-2005 for more information).



NOTE

Many types of equipment do not have an attachment point for bonding conductors. Equipment that does not have attachment points for bonding conductors may be bonded through the equipment rail. Equipment that cannot be bonded through the equipment rail (such as IT equipment on sliding trays) may be bonded through the equipment power cord. Bonding may be made through the power cord, provided the power cord contains an EGC and the electrical receptacle housing/conduit and/or Power Distribution Unit (PDU) that the cord plugs into is bonded with an equipment bonding conductor. In this instance, the shortest power cord practicable **shall** be used. Refer to the manufacturer's documentation for guidelines. See TIA-607-C, section 7.1 for more information.



Figure 5-87 Example of Equipment Bonding - Antenna Combiner

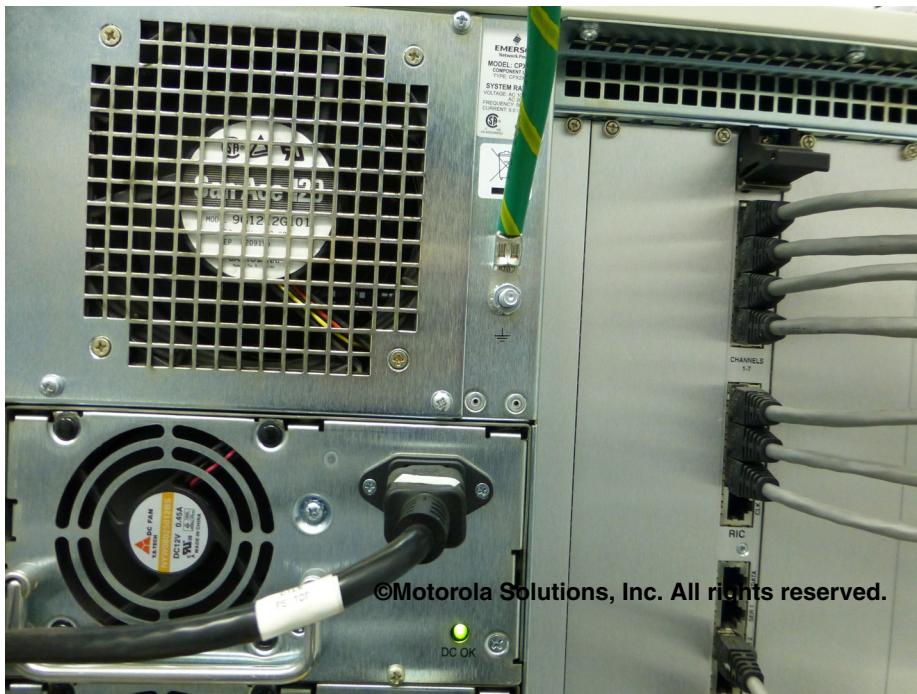

Figure 5-88 Example of Equipment Bonding - Base Station/Repeater



©Motorola Solutions, Inc. All rights reserved.

Figure 5-89 Example of Equipment Bonding - Channel Bank



©Motorola Solutions, Inc. All rights reserved.

Figure 5-90 Example of Equipment Bonding - Trunking Controller

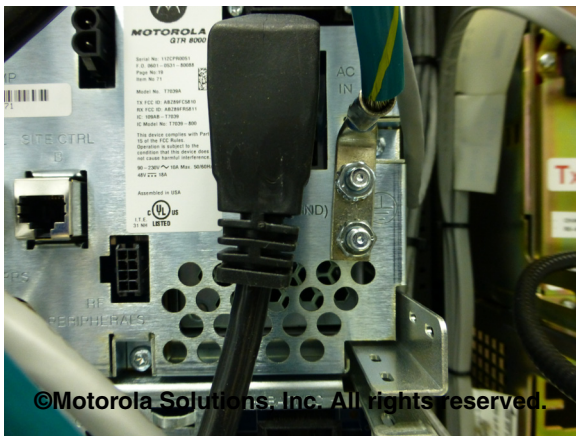

Figure 5-91 Example of Equipment Bonding - Base Station/Repeater

5.9.1.6 Cabinets and Racks

Bonding conductor connections to cabinets and racks **shall** be made at the designated ground (earth) connection point or ground “pad.” Connection to cabinets and racks without a designated connection point or ground pad **shall** be suitably made to the equipment mounting rail using bonding methods described within this chapter.

Racks or cabinets equipped with a Rack Bonding Bar (RBB) **shall** have an independent bonding jumper installed between the rack or cabinet grounding connection point and the RBB (see Figure 5-92). Where it is not practicable to install a rack bonding jumper to the RBB, the rack bonding jumper may be installed between the rack bonding/grounding connection point and the 35 mm² csa (#2 AWG) (or larger) RBB bonding bus conductor using methods described within this chapter. All equipment within the rack or cabinet **shall** be bonded to the RBB with an equipment bonding conductor using methods described within this chapter.

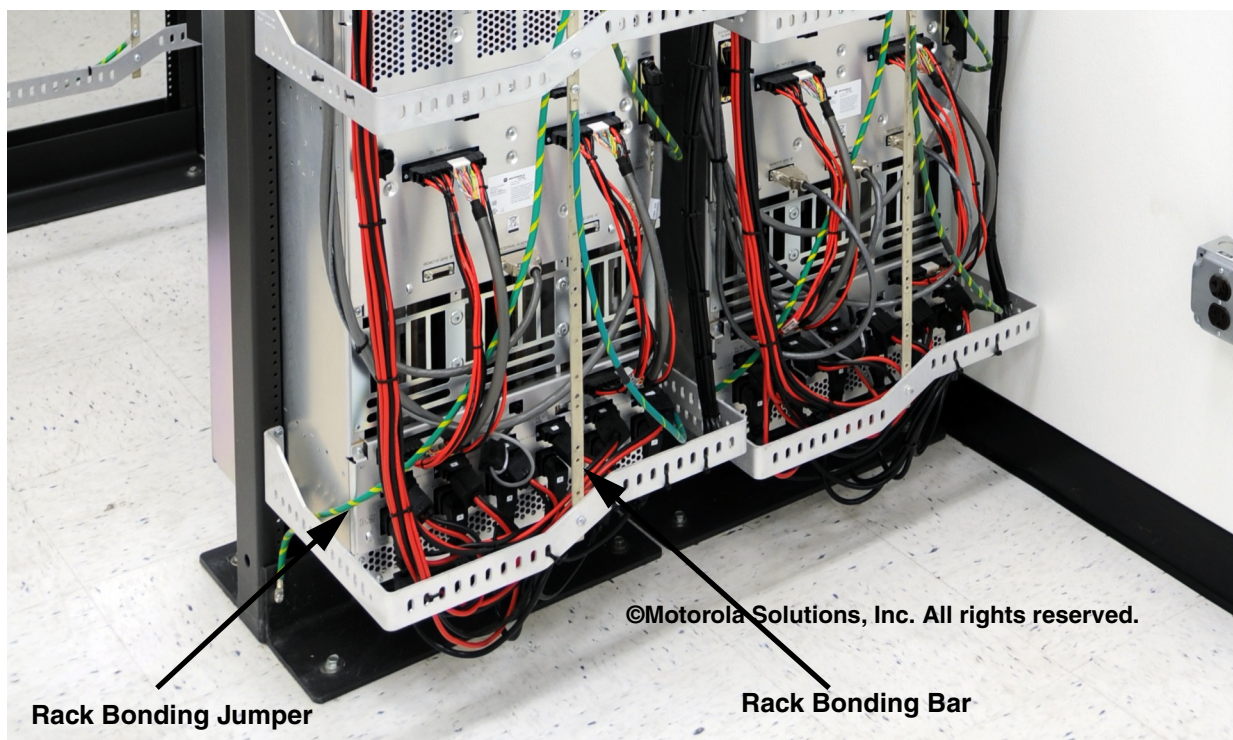

Figure 5-92 Example of Rack Bonding Jumper to Rack Bonding Bar

**IMPORTANT**

If a cabinet or rack is provided with DC power, see “Racks, Cabinets and Equipment Supplied from DC Systems” on page 5-94 for additional bonding requirements.

5.9.1.6.1 Structural Bonding of Cabinets and Racks

For cabinets and racks with welded construction, the welds serve as the method of bonding the structural members of the cabinet/rack together (see TIA-607-C, section 7.7).

For a bolted cabinets and racks, bonding continuity **shall not** be assumed through the use of normal frame bolts, unless the cabinet/rack is specifically designed and tested for integral bonding (see manufacturer specifications). These types of cabinets/racks use bonding hardware (for example, bolts, washers, nuts and screws) specifically designed to accomplish integral bonding of the cabinet/rack assembly. See TIA-607-C, section 7.7 for more information.

If a cabinet or rack is not specifically designed for integral bonding, the cabinet or rack may be retrofitted using one of the following (see TIA-607-C, section 7.7 for more information):

- Installing bonding jumpers between adjoining sections.
- Removing the paint from all bonding contact areas to ensure electrical continuity (per manufacturer recommendations).

**NOTE**

For the purpose of integral bonding, racks using welded construction are preferred over bolted construction.

All detachable, metallic parts of equipment cabinets (for example, frame, door, side panel(s), top panel and so on) **shall** be bonded. Bonding can be achieved using bonding jumpers or through bolted connections to the cabinet frame, contact fingers or other manufacturer designed bonding technique (see TIA-607-C, section 7.7 for more information).

Where a detachable, metallic panel part of a cabinet is bonded with a jumper, the jumper **shall** be a minimum size of 4 mm² csa (# 12 AWG), high strand count, insulated copper conductor with green or green with yellow stripe jacket. The bonding jumper should have an easily visible quick connect to facilitate detaching and attaching the panel or door (see Figure 5-93). See TIA-607-C, section 7.7 for more information.



Figure 5-93 Example of Removable Cabinet Door Bonding

5.9.1.7 Cable Trays

A cable tray system **shall** be effectively grounded as follows (see NFPA 70-2017, Article 250.96 and Part IV of Article 250 for more information):

- A cable tray system **shall** be effectively bonded to the Primary Bonding Bar (PBB) with a bonding conductor no smaller than 16 mm² csa (#6 AWG).
 - The bonding conductor **shall** also be sized according to length as shown in Table 5-4.
- If the PBB is not located within the equipment room or area, the cable tray system **shall** be effectively bonded to the main Secondary Bonding Bar (SBB) within that room or area using bonding methods described herein.
- Cable trays installed under a raised computer floor may be bonded to the bonding grid, if installed.
- Bonding conductor attachment to the PBB or SBB **shall** be made using bonding methods described within this chapter.
 - Typically a listed two-hole lug.
 - See “Connection Methods for Internal Bonding and Grounding (Earthing) System” on page 5-64.
 - See Table 5-1 and Table 5-2.
- Bonding conductor attachment to the cable tray **shall** be made using approved connection methods:
 - Typically a listed two-hole lug (see TIA 607-C, section 9.2).
 - Cable tray manufacturer designed bonding method.
 - See “Connection Methods for Internal Bonding and Grounding (Earthing) System” on page 5-64.
- See “Cable Tray Systems Supporting DC Conductors” on page 5-93 for additional bonding requirements for cable tray systems supporting DC conductors.



IMPORTANT

If a cable tray supports DC conductors, see “Cable Tray Systems Supporting DC Conductors” on page 5-93 for additional bonding requirements.

Where a cable tray system has been installed with a single section routing perpendicular to the PBB or SBB, the cable tray section nearest to the bonding bar **shall** have an equipment bonding conductor installed between one of the cable tray side rails and the PBB or SBB. The bonding conductor **shall** be installed with the shortest and straightest route as practicable. See Figure 5-94 for an example of this type of configuration.

Where a cable tray system has been installed with a “U” shape section routing perpendicular to the PBB or SBB, each cable tray section nearest to the bonding bar **shall** have an equipment bonding conductor installed between the cable tray side rail and the PBB or SBB. Each bonding conductor **shall** be installed with the shortest and straightest route as practicable. See Figure 5-94 for an example of this type of configuration.

Where a cable tray has been installed parallel to the PBB or SBB, the cable tray section nearest to the bonding bar **shall** have two equipment bonding conductors installed to provide a bi-directional flow path to the PBB or SBB. Each bonding conductor **shall** be installed with the shortest and straightest route as practicable. See Figure 5-94 for an example of this type of configuration.

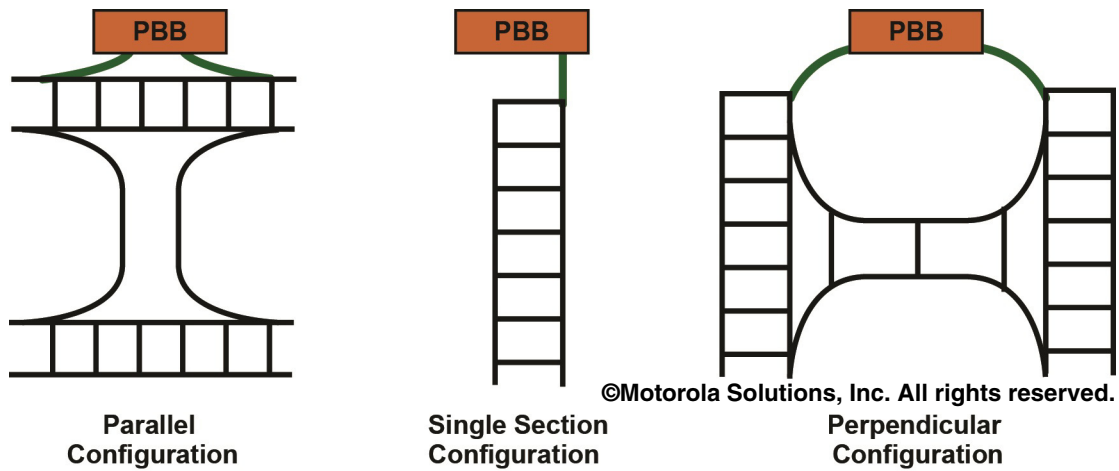

Figure 5-94 Cable Tray Bonding Configurations

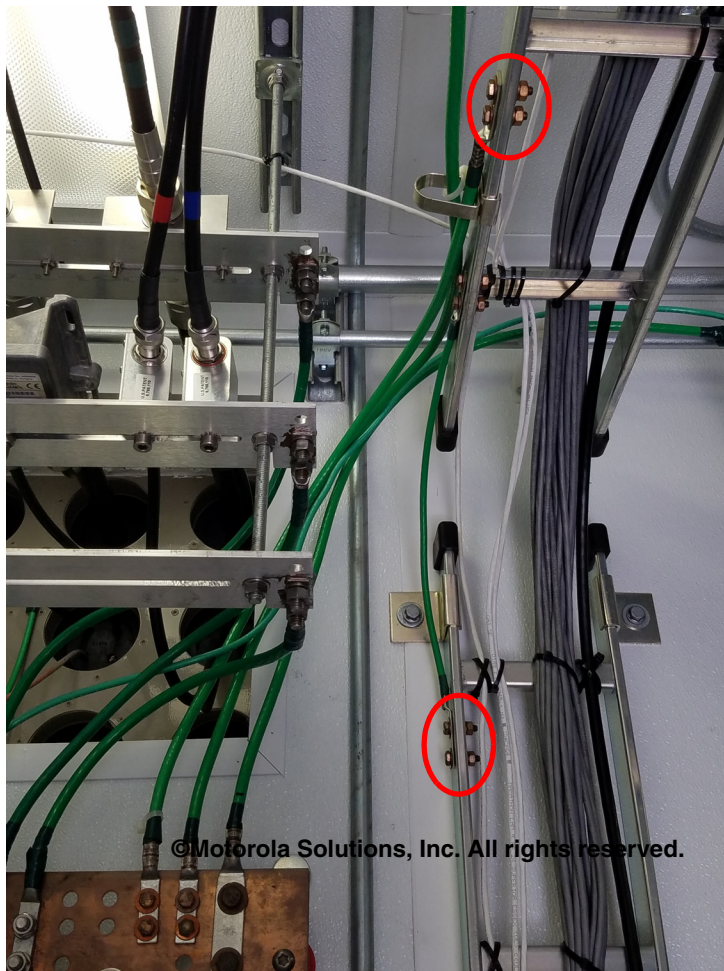

Figure 5-95 Example of Cable Tray Bonding to Primary Bonding Bar

Bonding jumpers **shall** be installed at all cable tray splices and connection points unless the cable tray has labeling that identifies it as suitable for use as an equipment grounding (earthing) conductor and it meets the requirements of NFPA 70-2017, Article 392.60(B) (see Figure 5-96). These type cable trays have bolted splices and the connection points use splined shoulder bolts which bite into the side rail of the cable tray to ensure a positive bond between sections. All bolts must be properly installed at each splice in the cable tray system per the manufacturer's instructions. Care must be taken to ensure a continuous electrical path. Bonding jumpers **shall** be used where discontinuities exist, such as expansion splice plates and hinged splice plates.



Figure 5-96 Cable Tray Listed as Equipment Grounding Conductor



IMPORTANT

Cable trays shall not be utilized as a bonding bus conductor for equipment or ancillary support apparatus.

A bonding jumper **shall** be installed between each cable tray section and between each piece of metallic non-current-carry support hardware to establish an effective current flow path to the PBB or SBB (BICSI 607-2011). All bonding jumpers **shall** be as short and straight as practicable. Where a bend is required in the bonding jumper, it **shall** adhere to the 203 mm (8 in.) minimum bending radius requirement. Cable trays with painted finishes or aluminum anodized finishes **shall** have the protective coating completely removed down to the bare metal at each bonding connection point, and the bonding connection point **shall** be treated with the appropriate type of conductive antioxidant compound before the bonding connection is established. See Figure 5-97 and Figure 5-98 for examples of cable tray bonding jumpers.

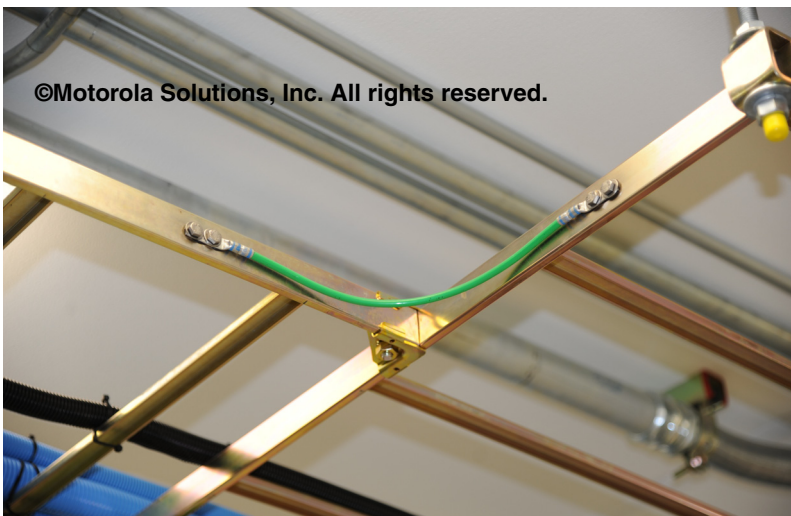

Figure 5-97 Example of Bonding Jumper Installed on Cable Tray System

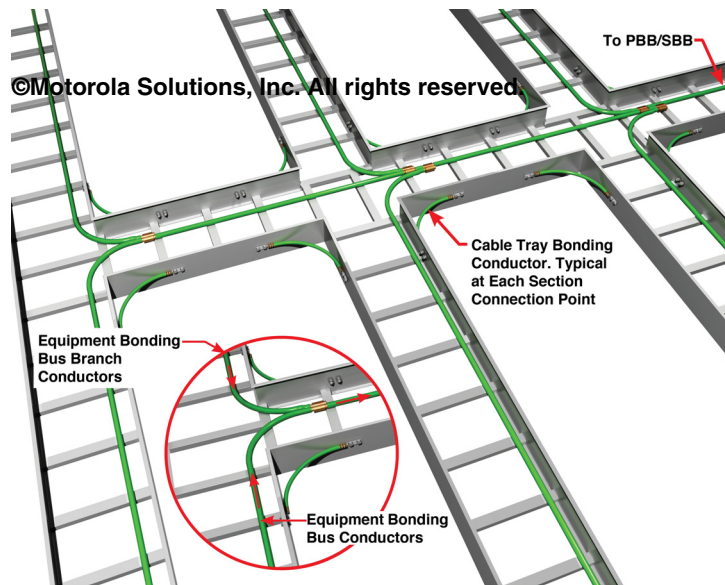

Figure 5-98 Example of Bonding Jumpers Installed on Cable Tray System (Top View)

5.9.1.8 Ancillary Support Apparatus

In order to help ensure an equal potential throughout a site/equipment room, all metallic ancillary support apparatus (see list in this section) within an equipment shelter, room or specific equipment area **shall** be bonded to the internal bonding and grounding system, using a bonding conductor as described in “Equipment Bonding Conductor” on page 5-46 and associated subsections.

Bonding can be made to any of the following:

- Primary Bonding Bar (PBB) (see “Master Ground (Earth) Bus Bar or Primary Bonding Bar” on page 5-10)
- Secondary Bonding Bar (SBB) (see “Sub System Ground Bus Bar or Secondary Bonding Bar” on page 5-17)
- Internal Perimeter Bonding Bus (IPBB) (typical) (see “Internal Perimeter Bonding Bus Conductor” on page 5-56)
- Bonding grid (see “Supplementary Bonding Network or Bonding Grid” on page 5-59)

Manufacturer's installation instructions (if available) **shall** be followed when bonding ancillary support apparatus to the site bonding system. Connections **shall** be made to the terminal provided or some other suitable point on the apparatus. Two-hole lugs **shall** be used over single hole lugs where practicable.

Metallic ancillary support apparatus that **shall** be bonded includes, but is not limited to, the following (see ATIS-0600334.2013, section 7.1):

- Ventilation louvers (see Figure 5-105)
- Exhaust fans (see Figure 5-104)
- Door frames and doors (see Figure 5-109)
- Electrical panels and panelboards (TIA-607-C) (see Figure 5-103)
- Switchboards
- Automatic and manual transfer switches.
- Exposed structural steel (ATIS-0600333.2013, section 5.2.1.2)
- Storage cabinets and desks
- Battery racks

- Window frames
- Ceiling grids
 - Bonding to the main ceiling support in at least two locations on opposite sides of the room is adequate for typical communications shelters/buildings (or equivalent) (see Figure 5-11 for an example). Larger equipment rooms should consider a bond on all sides.
 - The bond may be made to the PBB, SBB or IPBB.
- Raised flooring systems (see “Raised Computer Floor Bonding” on page 5-115)
- HVAC grills, ducts, units, motors, motor controllers, control panels, junction and terminal boxes (see Figure 5-101 and Figure 5-102)
- Dehydrators (see Figure 5-107)
- Unused entry ports (see Figure 5-108)
- Transformers and UPS units (see “Transformers, Inverters and UPS Systems (Containing Isolation Transformer)” on page 5-87)
- Metallic housing of AC power surge suppressor devices
- Primary surge suppressor ground terminals (bond per manufacturer instructions)
- Support apparatus, including metallic conduits, within an equipment shelter/room, a generator or power distribution room or specific equipment area and located within 2.4 m (8 ft) vertically or 1.5 m (5 ft) horizontally of ground or grounded metal objects and subject to contact by persons (NFPA 70-2017, Article 250.110 and Parts V and VI).
- Electrical conduits (typically bonded to the IPBB near the terminating electrical panel). See Figure 5-99 and Figure 5-100.
- Set-screw type electrical conduit connectors and couplings **shall** be bridged with a bonding jumper. Set-screw-type couplings should be avoided (IEEE 1100-2005, section 8.4.8.2).
- Rigid Metallic Conduit (RMC) and Electrical Metallic Tubing (EMT).
 - **Exception:** where the conduits are effectively joined with threaded coupling, threadless coupling or threadless compression connector, that terminate in bonded metallic enclosures, they may be considered adequately bonded and do not require additional bonding (ATIS-0600334.2013, section 7.7).
 - If a conduit does not meet the above specifications (such as set-screw type couplings), the electrical conduits **shall** be bonded (typically to the IPBB).

**NOTE**

Multiple conduits may be bonded with a single continuous 16 mm² csa (#6 AWG) bonding conductor using removable saddle clamps or other clamps that specifically permit the use of a single continuous conductor for bonding multiple runs of conduits. If multiple conduits are bonded using a single conductor, the conductor **shall** be clamped to each conduit run such that removal of one clamp does not interrupt the path to ground for the other conduit runs. See Figure 5-99 and Figure 5-100 for examples.

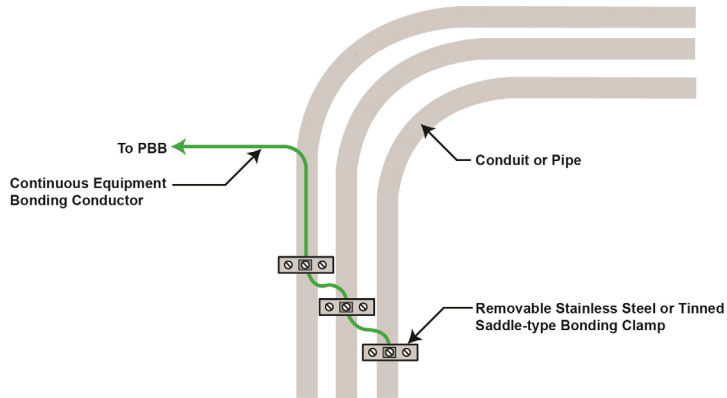

©Motorola Solutions, Inc. All rights reserved.

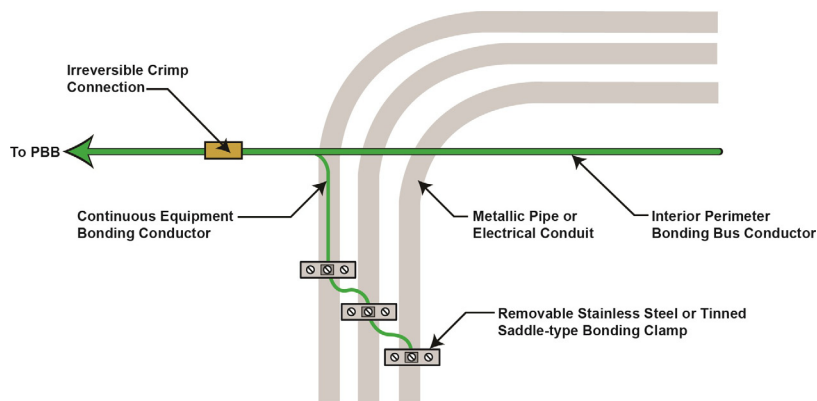

Figure 5-99 Bonding Method for Metallic Pipe or Conduit

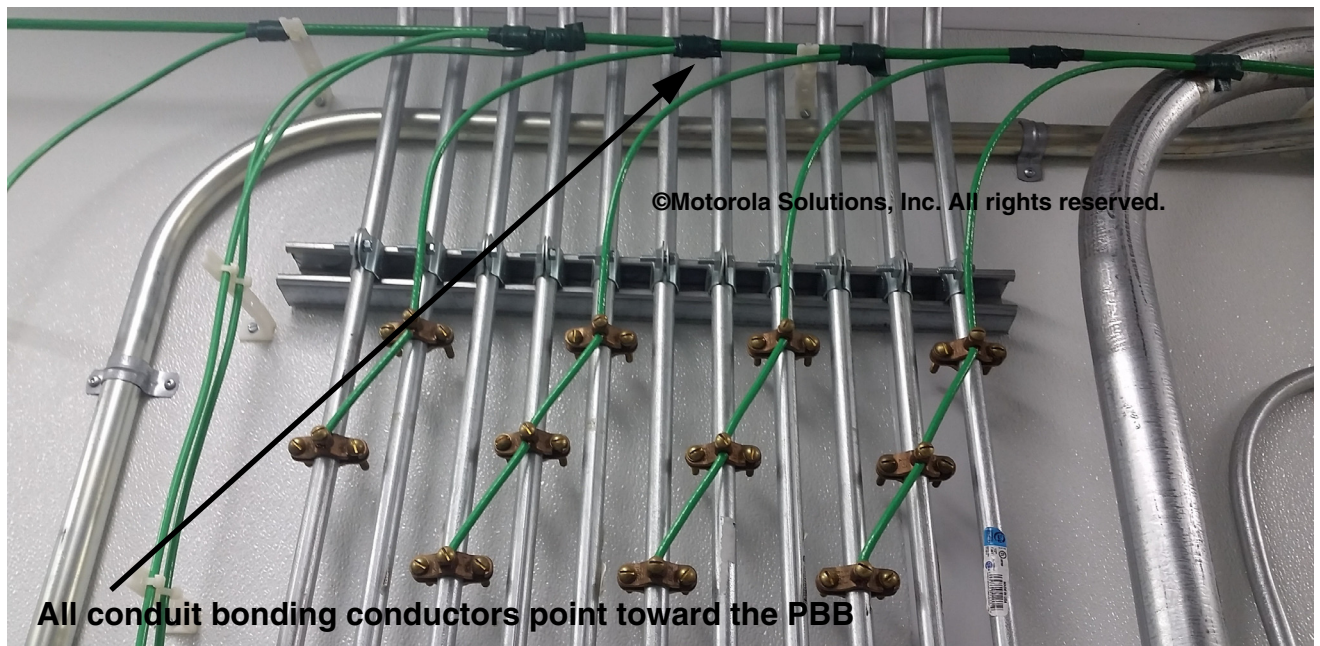

Figure 5-100 Example of Bonding Conduit to Internal Perimeter Bonding Bus

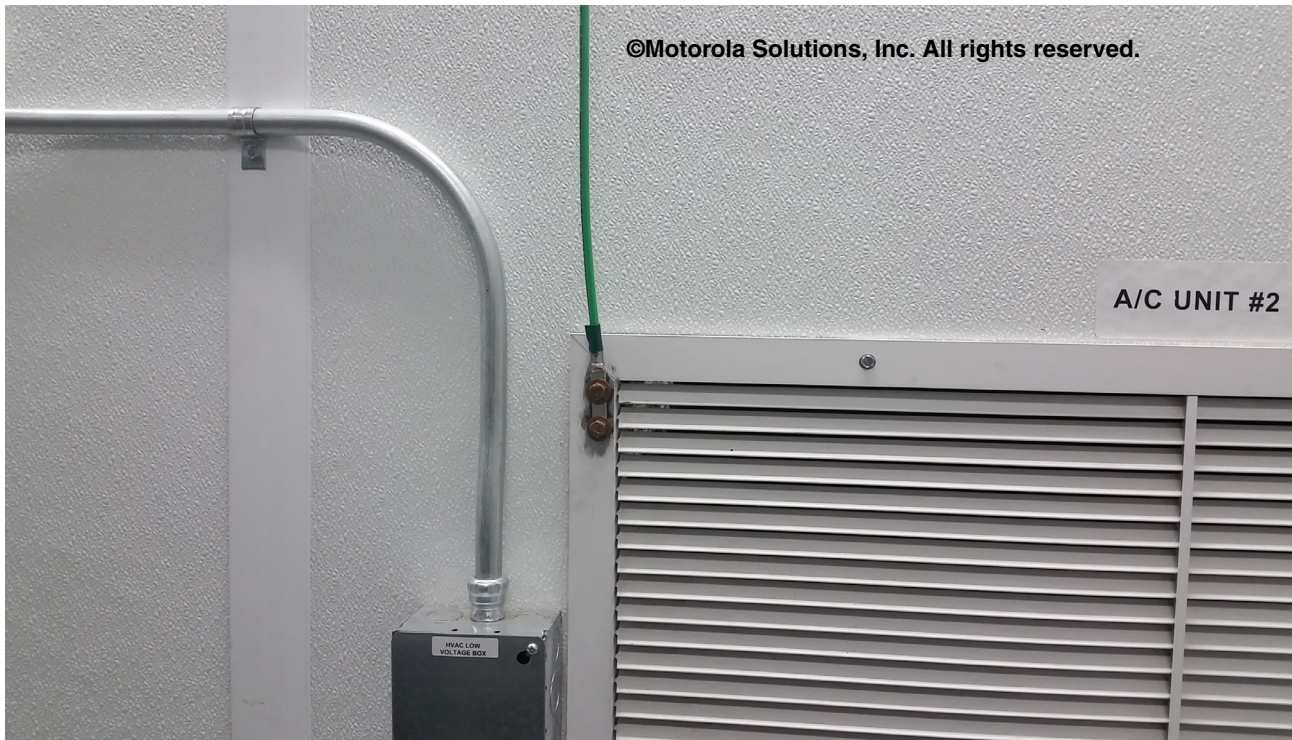

Figure 5-101 Example of HVAC Grill Bonding

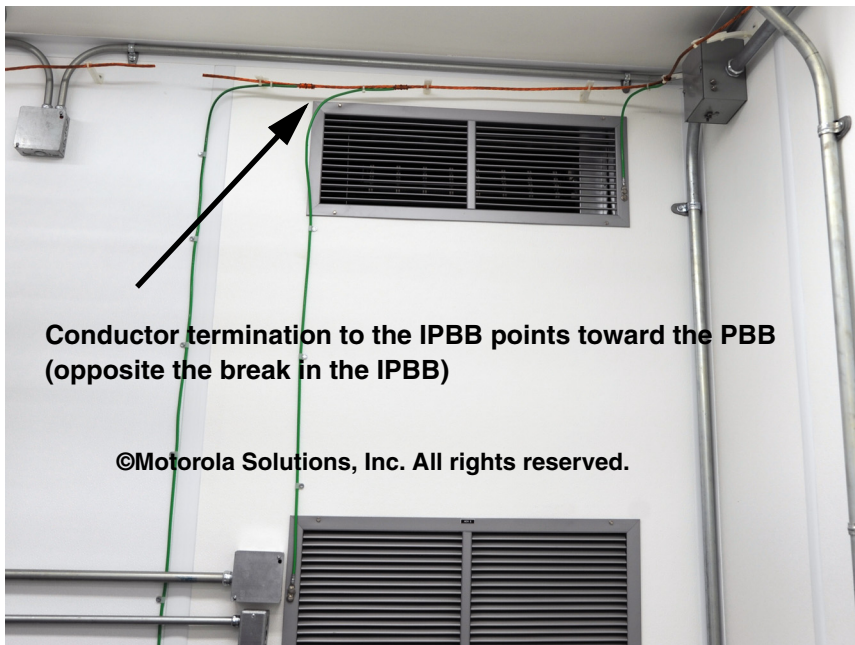

Figure 5-102 Example of Bonding HVAC Grills to Internal Perimeter Bonding Bus



Figure 5-103 Example of Bonding Electrical Panelboard to Internal Perimeter Bonding Bus



Figure 5-104 Example of Bonding Exhaust Fan to Internal Perimeter Bonding Bus



Figure 5-105 Example of Exhaust Louver Bonding



Figure 5-106 Example of Bonding Fresh Air Vent for Generator Room to Internal Perimeter Bonding Bus



Figure 5-107 Example of Bonding Dehydrator and Shelf to Internal Perimeter Bonding Bus



Figure 5-108 Example of Bonding Unused Entry Port to Internal Perimeter Bonding Bus



IMPORTANT

Unused entry ports and similar items that are electrically continuous should only be bonded either inside the shelter or outside, but not at both locations. Bonding at both locations can compromise the single-point grounding concept.

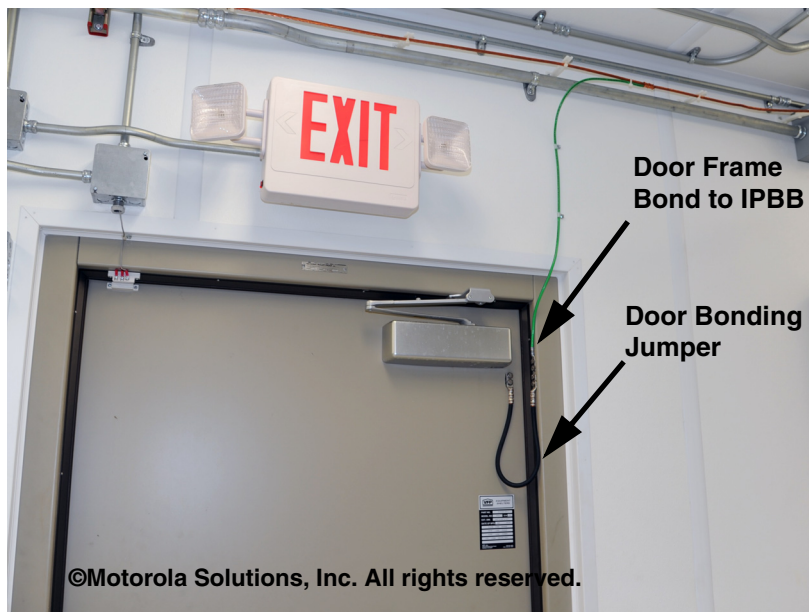

Figure 5-109 Example of Bonding Door Frame to Internal Perimeter Bonding Bus



NOTE

Doors are typically bonded using a highly flexible conductor, such as welding cable. Door bonding conductors may not be able to meet the conductor bending radius requirements due to the opening and closing of the door.

5.9.1.9 Metallic Building Structure and Piping Systems

Metallic building structures and piping systems, steel roof trusses, exposed support beams and columns, drop ceiling grids, raised floor support structure, any metallic exposed building support structure and building frame where located within 2.4 m (8 ft) vertically or 1.5 m (5 ft) horizontally of the communications equipment, **shall** be bonded to the Primary Bonding Bar (PBB), Secondary Bonding Bar (SBB), Internal Perimeter Bonding Bus (IPBB) or bonding grid using one of the conductors and methods described within this chapter. See Figure 5-110.

No series or daisy chain connection arrangements **shall** be used. Each peripheral device **shall** be bonded to the PBB, SBB, IPBB or bonding grid using an individual equipment bonding conductor.

©Motorola Solutions, Inc. All rights reserved.

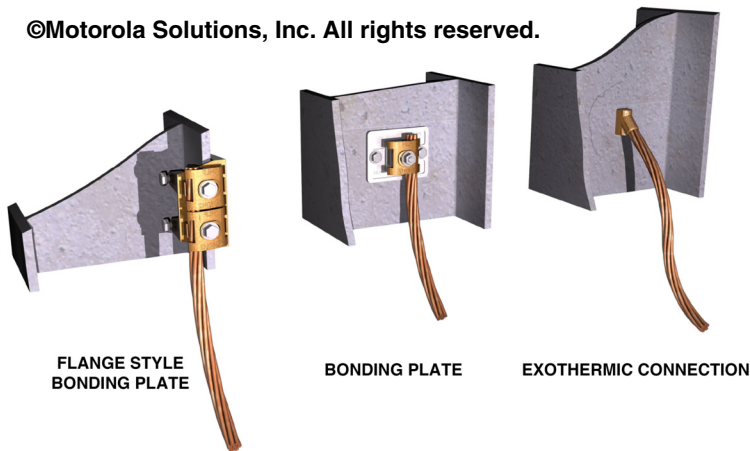
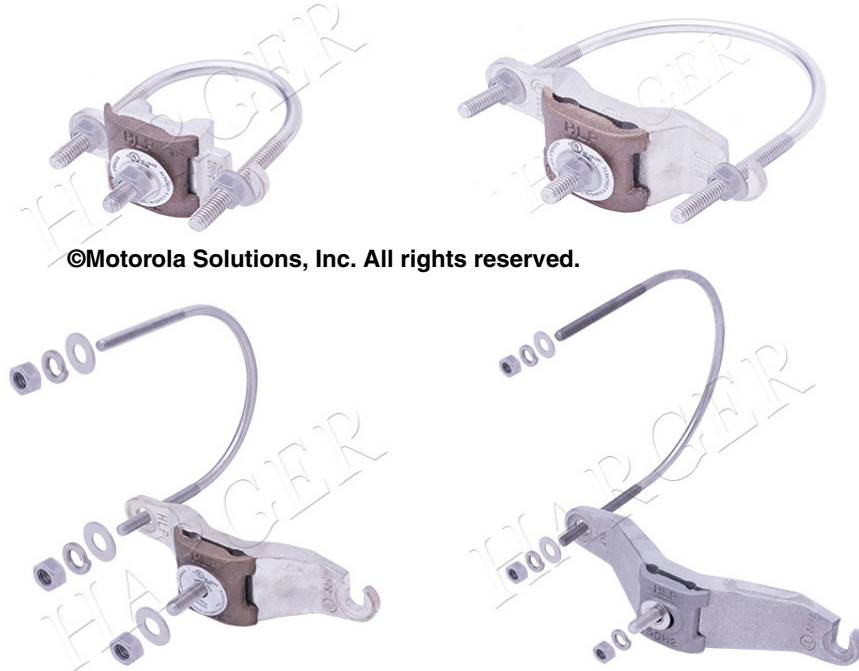

Figure 5-110 Examples of Acceptable Structural Building Steel Bonding Connections



©Motorola Solutions, Inc. All rights reserved.

Figure 5-111 Examples of Pipe Bonding Clamps

5.9.1.10 Raised Computer Floor Bonding

In order to help ensure an equal potential throughout a computer/IT room and/or dispatch area, a raised computer floor **shall** be bonded to the internal bonding and grounding system as described in the following subsections.

5.9.1.10.1 Raised Computer Floors Designed with Integrated Bonding

Some raised computer floors are designed to provide electrical continuity throughout the system (see manufacturer specifications). These systems may include one or more of the following:

- Stringers designed to provide electrical continuity
- Bonding/grounding clips designed to provide electrical continuity
- Specific construction designed to ensure electrical continuity



IMPORTANT

See “Bonding and Grounding (Earthing) for Dispatch Centers and Network Operator Positions” on page 5-133 for additional bonding requirements at these locations.

Raised computer floor systems of this type **shall** be bonded to the internal bonding system as follows:

- Each computer/IT room and/or dispatch area **shall** contain at least one Secondary Bonding Bar (SBB) (TIA-607-C, section 7.1.3).
- If the facility has a bonding backbone with more than one vertical riser or horizontal backbone conductor, the computer/IT room and/or dispatch area **shall** contain at least two SBBs (one SBB for each respective vertical riser or horizontal backbone conductor) as practicable.
 - The SBBs **shall** be installed horizontally opposed as much as practicable and installed near each respective bonding backbone conductor.
 - Each SBB **shall** bond to the nearest location on the bonding backbone.
- Bonding of the floor to the SBB(s) **shall** be made in at least four locations of the computer/IT room and/or dispatch area (see ATIS-0600321.2015, section 7.7.2).
 - The corners are the preferred bonding locations.
- The minimum size floor bonding conductor **shall** be a 16 mm² csa (# 6 AWG) (ATIS-0600333.2013, section 5.6.2).
 - The bonding conductor size **shall** also meet the requirements of “Bonding and Grounding (Earthing) Conductor Length and Gauge Requirements” on page 5-39.
- Bonding to the floor **shall** be made at the manufacturer provided/recommended bonding locations, if applicable. Otherwise bonding **shall** be made to nearby floor pedestals using approved bonding hardware (see Figure 5-112 and Figure 5-113).
- Bonding conductors **shall** meet the requirements of “Bonding and Grounding (Earthing) Conductors” on page 5-39 and all applicable subsections.

If a bonding grid is not installed at the site, the following **shall** apply:

- The preferred method of bonding all corners is to install a bonding conductor around the perimeter of the floor and terminate each end of the conductor to opposite sides of the SBB (forming a floor bonding loop). If more than one SBB is installed, each SBB **shall** be bonded to the floor bonding loop.
 - Bond each corner area of the floor system to this conductor using appropriate hardware (see Figure 5-112).
 - The minimum size for this bonding conductor **shall** be a 16 mm² csa (# 6 AWG)
 - The bonding conductor size **shall** also meet the requirements of “Bonding and Grounding (Earthing) Conductor Length and Gauge Requirements” on page 5-39, with the following exception:
 - The conductor length can be doubled for a given conductor gauge. For example, a 16 mm² csa (#6 AWG) can be

used for a floor bonding loop up to 8 m (26 ft), because the conductor is installed in a loop, creating two paths.

- The bonding conductor may be bare or jacketed. If the conductor is bare, it **shall** be properly secured to prevent incidental contact with the concrete floor and/or other metallic items (see Figure 5-112 and Figure 5-113).

If a bonding grid is installed at the site (see “Supplementary Bonding Network or Bonding Grid” on page 5-59), the following **shall** apply:

- Bond each corner area of the floor system to the grid using appropriate hardware (see Figure 5-112 and Figure 5-113).
- Bond at least every four (4) to six (6) floor pedestals in each direction (TIA-607-C, section 7.8.1). See Figure 5-112 and Figure 5-113.
- If applicable, bond each dispatch/network operator position Secondary Bonding Bar (SBB) to the bonding grid (see “Bonding and Grounding (Earthing) for Dispatch Centers and Network Operator Positions” on page 5-133).

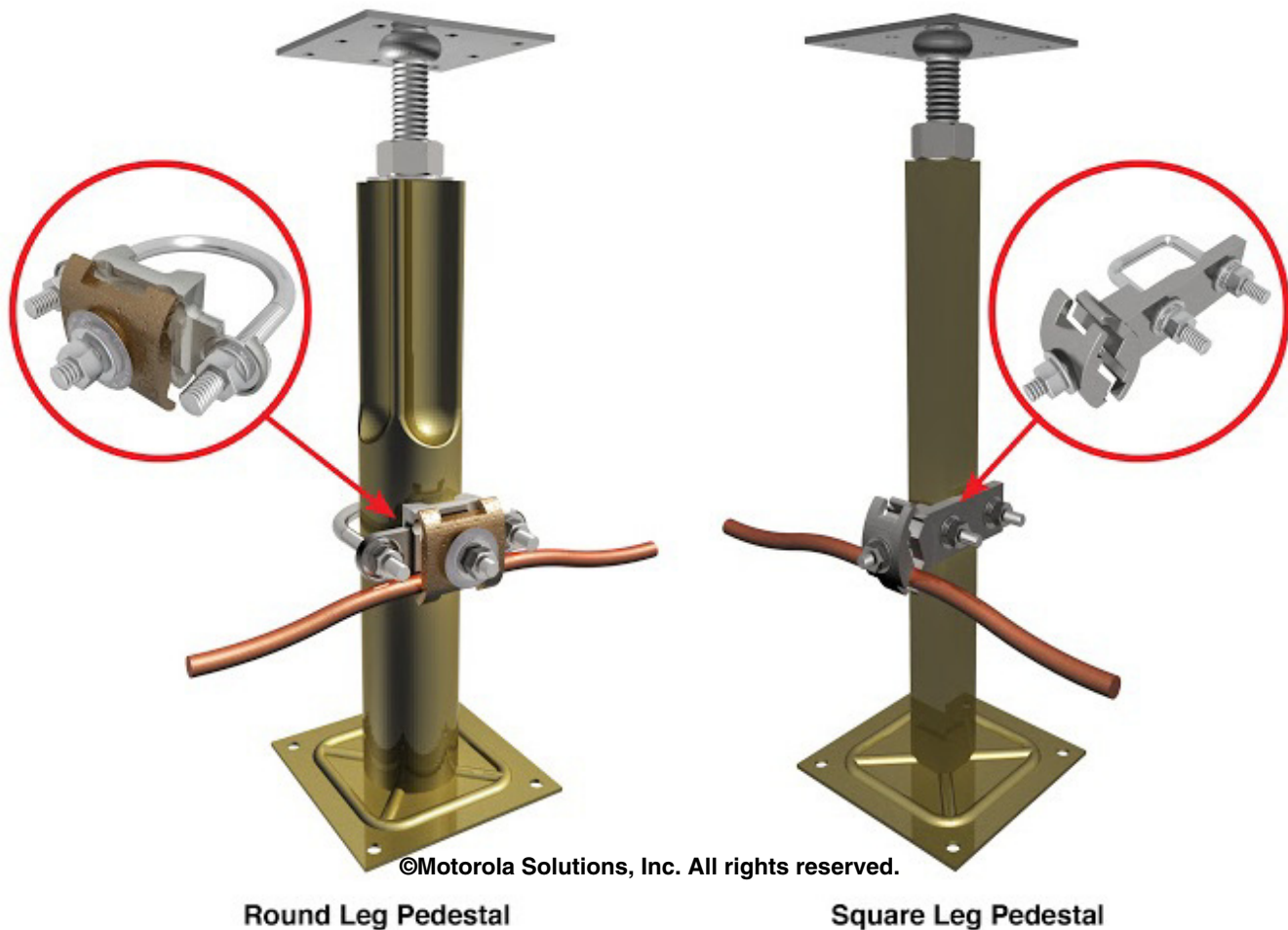

Figure 5-112 Acceptable Raised Flooring Bonding Connections

5.9.1.10.2 Raised Computer Floors Not Designed with Integrated Bonding

Some raised computer floors are not designed to provide electrical continuity throughout the system (see manufacturer specifications). These systems **shall** be made electrically continuous through proper bonding and grounding.

Proper bonding and grounding is achieved with the installation of a supplementary bonding network in the form of a bonding grid installed under the floor (which may be referred to as a mesh-bonding network or mesh-BN) (see TIA-607-C, section 7.1.3 for more information). This bonding grid is used for bonding of the floor system, as well as electronic equipment and ancillary support equipment installed in the computer/IT room and/or dispatch area (such as dispatch position Secondary Bonding Bar (SBB). See “Supplementary Bonding Network or Bonding Grid” on page 5-59.

**IMPORTANT**

See “Bonding and Grounding (Earthing) for Dispatch Centers and Network Operator Positions” on page 5-133 for additional bonding requirements at these locations.

A bonding grid system (mesh-BN) **shall** be installed under the raised computer floor as follows:

- A bonding grid installed according to “Supplementary Bonding Network or Bonding Grid” on page 5-59.
- Bond each corner area of the floor system to the bonding grid using appropriate hardware (see Figure 5-112 and Figure 5-113) (ATIS-0600321.2015, section 7.7.2).
- Bond at least every four (4) to six (6) floor pedestals in each direction (TIA-607-C, section 7.8.1).
- If applicable, bond each dispatch/network operator position SBB to the bonding grid (see “Bonding and Grounding (Earthing) for Dispatch Centers and Network Operator Positions” on page 5-133).

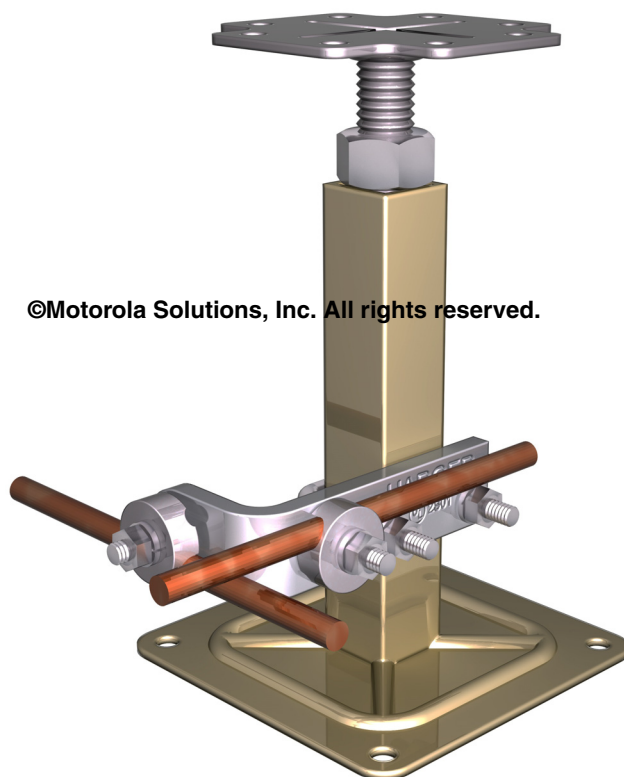

Figure 5-113 Bonding Conductors Suspended on Raised Flooring Pedestals

5.9.1.11 Surge Protective Devices

All surge protective devices and outside telecommunication cable metallic shields including, but not limited to, the following items **shall** be effectively bonded to the internal bonding and grounding (earthing) system as described within this section:

- “RF Surge Protective Devices” on page 5-118

- “Primary Surge Protective Devices” on page 5-120
- “Secondary Surge Protective Devices” on page 5-120
- “Telecommunication Cable Metallic Shields” on page 5-122

5.9.1.11.1 RF Surge Protective Devices

RF transmission Surge Protective Devices (SPDs) **shall** be bonded to the Primary Bonding Bar (PBB) or a Secondary Bonding Bar (SBB) within 610 mm (24 in.) of entry into the equipment shelter, equipment room or equipment area. A separate bonding conductor **shall** be used to bond each SPD to the PBB or SBB. RF transmission line SPDs may also be bonded directly to an SBB, PBB or copper integrated entry panel with the proper securing hardware. See Figure 5-114, Figure 5-115 and Figure 5-116.

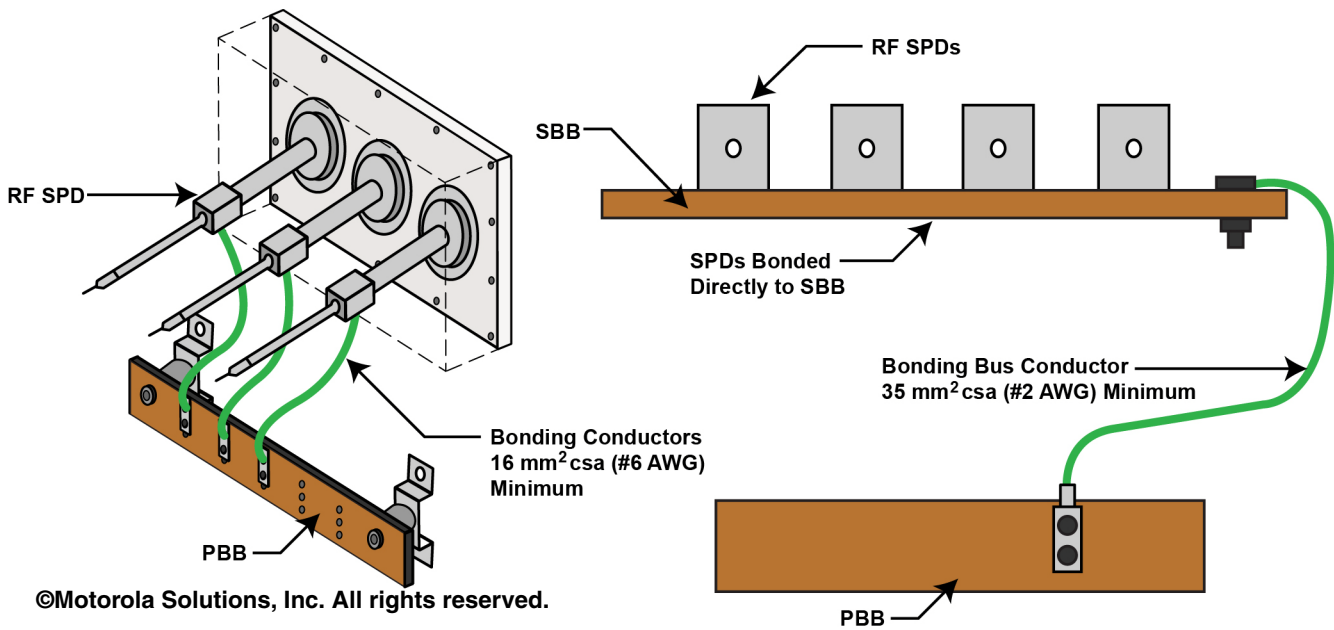

Figure 5-114 RF Surge Protective Device Bonding to Secondary Bonding Bar with Bonding Bus Conductor

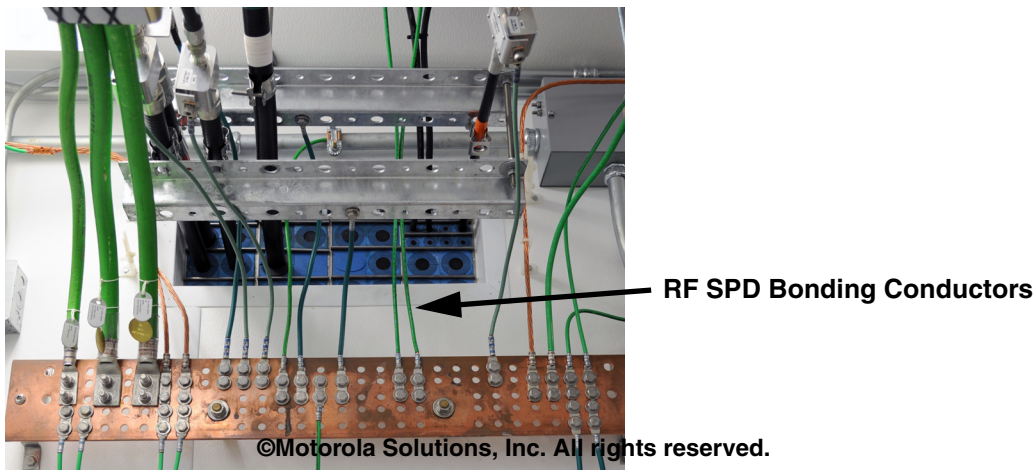

Figure 5-115 Example of RF Surge Protective Devices Bonding to Primary Bonding Bar with Separate Bonding Conductors

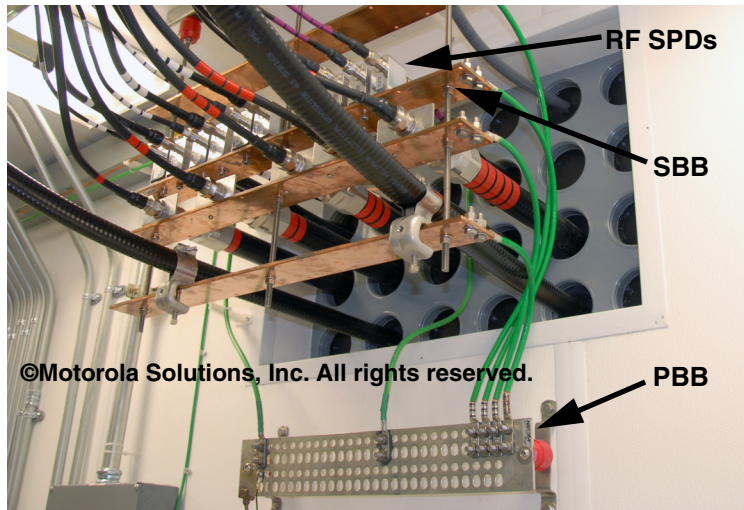

Figure 5-116 Example of RF Surge Protective Devices Bonding Directly to Secondary Bonding Bars

If RF transmission lines enter the building at a point other than where the equipment room or area is located, there is no requirement for SPDs to be installed at the building entry location (see Chapter 7, “Surge Protective Devices”). The shield of the RF transmission line **shall** be effectively bonded to the grounding electrode system at the point of entry into the building or as near as practicable (see “External Ground Bus Bar” on page 4-43 and “Ground Kit Location” on page 4-98 for more information (ATIS-0600313.2013, section 10.5.3; ATIS-0600334.2013, section 6.6; NFPA 70-2017, Articles 800.100, 810.20, 810.21, 820.93, 830.93 and 830.100).

Where an RF transmission line SPD is placed at the equipment shelter, equipment room or equipment area entry point and that entry point is greater than 6.1 linear meters (20 linear ft) away from the Primary Bonding Bar (PBB), an Entry Point SBB **shall** be installed according to “Secondary Bonding Bar Serving an Entry Point” on page 5-26, and the RF SPD **shall** bond to the entry point SBB as described in this section. See Figure 5-117 and Figure 5-118.

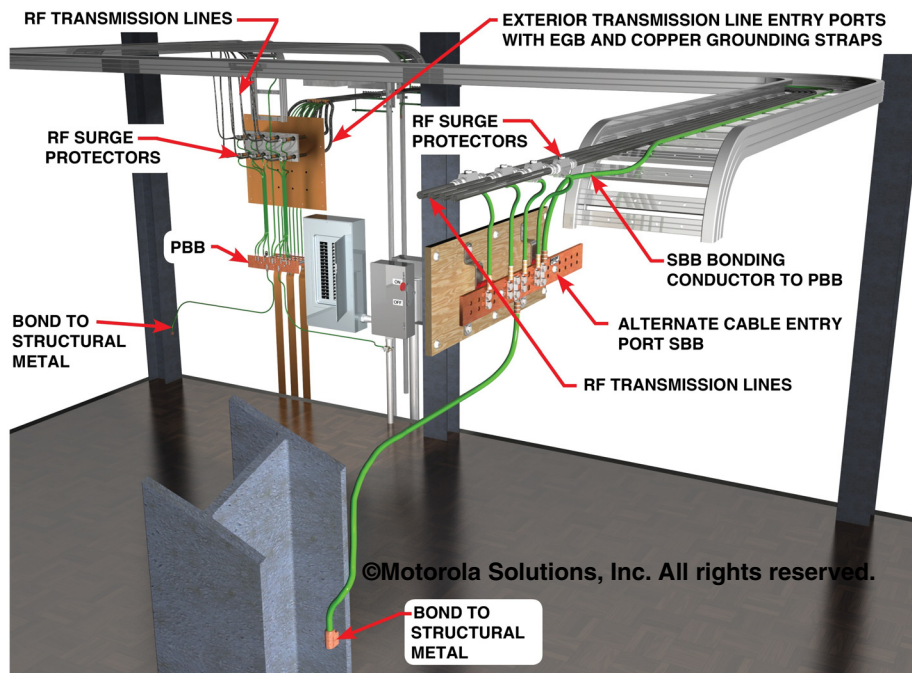

Figure 5-117 Cable Entry Greater Than 6.1 Linear Meters (20 Linear ft) from PBB Grounding Electrode System



NOTE

All conductor sizes given in Figure 5-118 represent the minimum size.

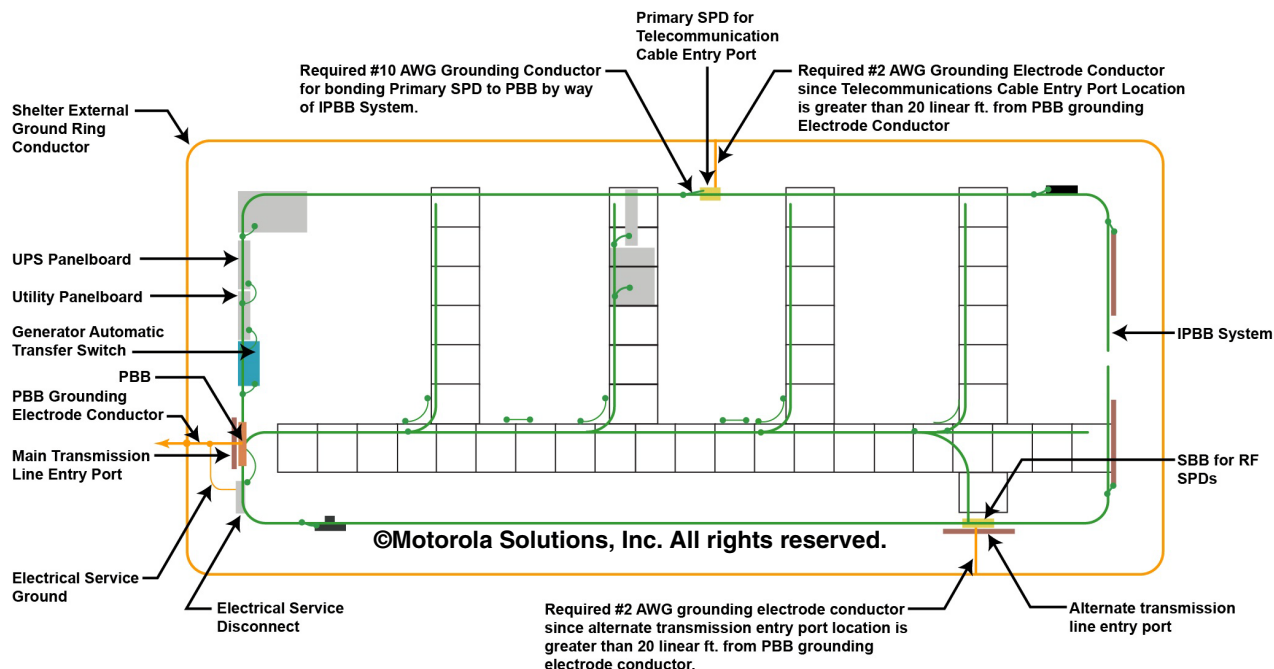

Figure 5-118 Cable Entry Greater Than 6.1 Linear Meters (20 Linear ft) from PBB Grounding Electrode System

5.9.1.11.2 Primary Surge Protective Devices

Primary Surge Protective Devices (SPDs) for telephone circuits, data circuits and control circuits **shall** have the ground (earth) terminal bonded to the Primary Bonding Bar (PBB), Secondary Bonding Bar (SBB) or a dedicated bonding bus conductor with an equipment bonding conductor using methods described within this chapter. The bonding conductor minimum size for a single line primary SPD **shall** be 6 mm² csa (# 10 AWG); the bonding conductor minimum size for multiple line primary SPDs **shall** be 16 mm² csa (# 6 AWG) (see ATIS-0600318.2010, section 7.1.3.3; ATIS-0600321.2015, section 7.2; and NFPA 70-2017, Article 800.100 for more information). The bonding conductor **shall** also meet the size requirements of Table 5-4.

Where a primary SPD is placed at an entry point other than adjacent to the PBB and that point is greater than 6.1 linear meters (20 linear ft) away from the grounding electrode of the PBB, a grounding electrode conductor **shall** be properly installed between the primary SPD grounding terminal or its SBB to the nearest accessible location on the common grounding electrode system as covered under NFPA 70-2017, Articles 800.100 and 830.100. See Figure 5-118 for an example of this type of grounding configuration.

In both cases, the bonding or grounding electrode conductors **shall** maintain a minimum 0.3 m (1 ft) separation between cables of different cable groups, even where the conductor is placed in rigid metallic conduit (TIA-607-C, section 7.2.2).

5.9.1.11.3 Secondary Surge Protective Devices

All secondary SPDs for telephone circuits, data circuits and control circuits **shall** be located as near as practicable to the equipment they are protecting. A separate equipment bonding conductor **shall** be used to bond each secondary SPD grounding conductor or ground terminal to the Primary Bonding Bar (PBB), Secondary Bonding Bar (SBB), Rack Bonding Bar (RBB) or bonding bus conductor that serves the associated equipment. The bonding conductor minimum size for a single line secondary SPD **shall** be 6 mm² csa (# 10 AWG); the bonding conductor minimum size for multiple line secondary SPDs **shall** be 16 mm² csa (# 6 AWG) (see ATIS-0600318.2010, section 7.1.3.3; ATIS-0600321.2015, section 7.2; and NFPA 70-2017, Article 800.100 for more information). The bonding conductor **shall** also meet the size requirements of Table 5-4.

Where several secondary SPDs are installed at an equipment rack or cabinet, the SPDs should be placed at a central location within the rack or cabinet so they can be effectively bonded to the equipment rack or cabinet RBB or to a separately installed RBB. If a separate RBB is installed for the SPDs, it **shall** be effectively bonded to the equipment bonding bus system using methods described in this chapter. See Figure 5-119.



Figure 5-119 Surge Protective Devices Installed at Equipment Rack or Cabinet



IMPORTANT

In order to prevent transients from coupling to the protected side of a cable, the protected and unprotected sides of the cables must be kept physically isolated from one another as much as practicable and by at least 100 mm (4 in.). The suggested best practice is to run the unprotected side down one side of the rack and the protected side down the other side. See Figure 5-120 for an example.

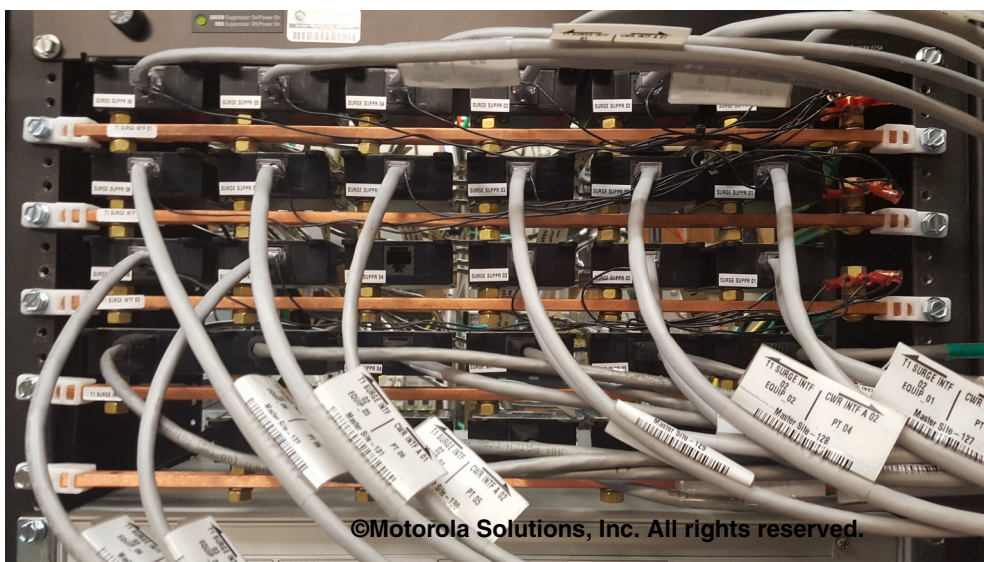

Figure 5-120 Example of Multiple Line Secondary Surge Protective Device

5.9.1.11.4 Telecommunication Cable Metallic Shields

Telecommunication cable metallic shields **shall** be bonded to the site's grounding electrode system as described in Chapter 4, "External Grounding (Earthing) and Bonding", or bonded as described in this section. Where outside facility telecommunication cables are configured for a standard entrance, the metallic members of all incoming telecommunication cables, including paired-conductor and optical fiber cable, **shall** be bonded to the Primary Bonding Bar (PBB), either directly or through a Secondary Bonding Bar (SBB) at the facility's entrance point. Each metallic member **shall** be effectively bonded to the grounding point with a 16 mm² csa (#6 AWG) or larger green-jacketed conductor or with a transmission line ground kit, using methods described within this chapter. See Figure 5-121.

Where the internal bonding and grounding system is configured for functional categories 0 - 7 or PANI, the metallic members **shall** be bonded to reference point 0 or P. See "PANI Method" on page 5-76 and ATIS-0600313.2013 for more information.

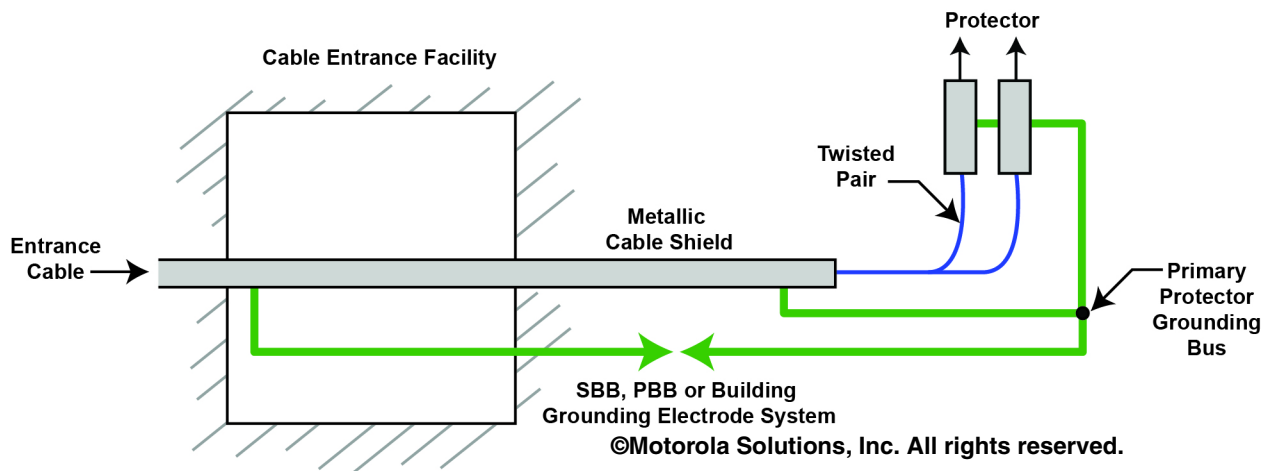

Figure 5-121 Standard Telecommunications Cable Entry Location

Where outside facility telecommunication cables are configured for an isolation entrance, the metallic member on the field side of the isolation gap **shall** be bonded to the PBB, either directly or through an SBB at the facility's entrance point (see Figure 5-122). The bonding connection point for a PANI configured bonding bar will be reference point P. The metallic member on the facility side of the isolation gap **shall** only be grounded at the primary SPD grounding terminal, which is bonded to the SBB or to the PBB at the PANI reference point P. In this type environment, the metallic members of all telecommunication cables entering the facility **shall** be isolated with a minimum 76 mm (3 in.) isolation gap. The isolation gap **shall** be sealed and insulated to prevent moisture penetration and flashovers during high voltage events. The grounding conductor for each side of the metallic member **shall** be a 16 mm² csa (#6 AWG) or larger and green-jacketed. The grounding conductor **shall** be effectively bonded to the referenced grounding point using bonding methods described within this chapter. See "PANI Method" on page 5-76 and ATIS-0600313.2013 for more information.

NOTE

Isolation gaps, which interrupt the metallic members of all cables, may be installed in some locations as a protective measure against high lightning incidence. This method should be used with caution because it tends to compensate for electrical protection deficiencies in the outside plant (ATIS-0600313.2013, section 8.2.2). Consultation with an engineer is recommended in these instances.

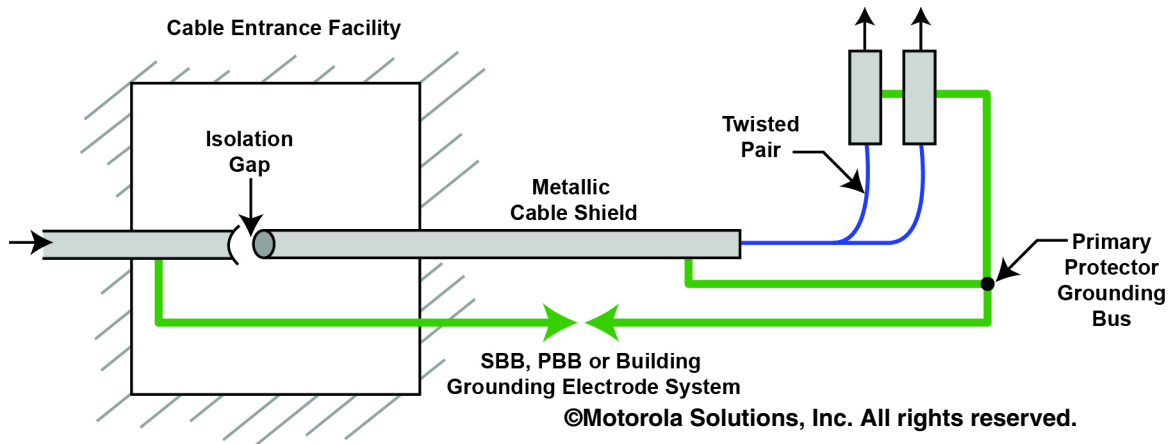

Figure 5-122 Isolation Type Telecommunications Cable Entry Location

Where the outside facility telecommunication cables are configured for an insulating entrance, the metallic members **shall** be bonded on each side of the insulating joint (see Figure 5-123). The facility side of the insulating joint **shall** be bonded to the PBB, either directly or through an SBB at the facility's entrance point. The bonding point for a PANI configured bus bar will be reference point P. The grounding conductor for each metallic member on the facility side of the insulating joint **shall** be a 16 mm² csa (#6 AWG) or larger and green-jacketed. The grounding conductor **shall** be effectively bonded to the referenced grounding point using bonding methods described within this chapter. On the field side of the insulating joint, all metallic members and all associated metal are deliberately isolated from the site's common grounding electrode system. See "PANI Method" on page 5-76 and ATIS-0600313.2013 for more information.

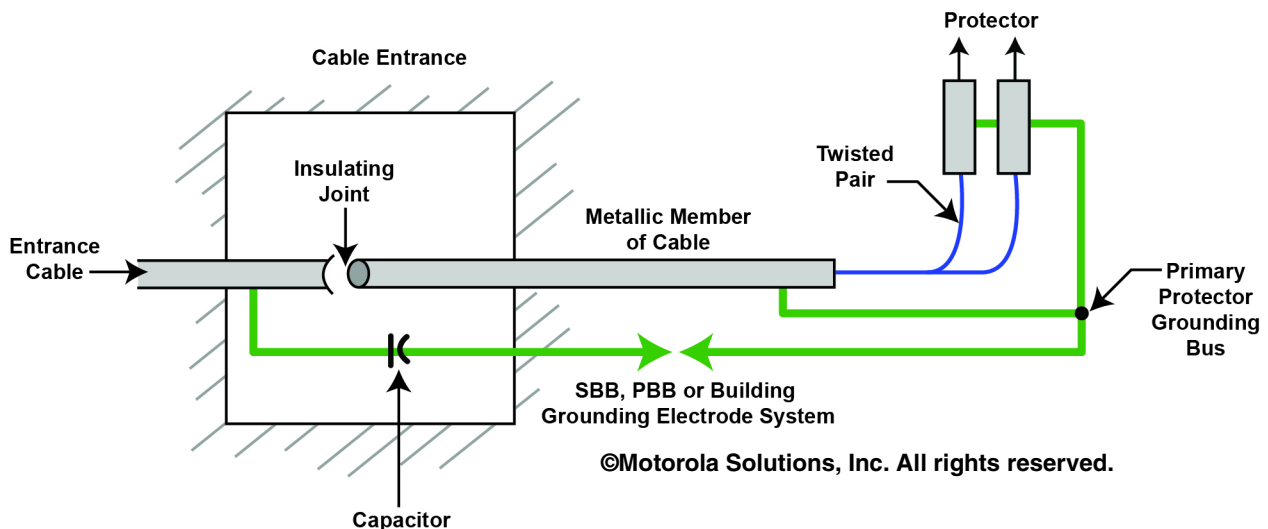

Figure 5-123 Insulating Type Telecommunications Cable Entry Location

Where internal building backbone telecommunication cables incorporate a shield or metallic member, the shield or metallic member **shall** be effectively bonded to the closest PBB or SBB with a 16 mm² csa (#6 AWG) or larger, green jacketed, grounding conductor at the point where cables terminate or where they are broken out. See TIA-607-C, section 7.1, for more information.

5.10 Bonding and Grounding (Earthing) for Specific Site Types

Proper bonding and grounding of communications equipment is essential for personnel safety, system reliability and system availability. With increases in circuit density and the advent of lower-voltage integrated circuit devices, communications and electronic equipment are more vulnerable than ever to damage resulting from lightning activity, power line anomalies and electrostatic discharge. Inadequate or improper equipment bonding and grounding can permit a difference of electrical potential to exist between system components, which may result in injury to personnel, system failure and equipment damage.



IMPORTANT

Bonding and Grounding (Earthing) alone are not enough to adequately protect a communications site. Appropriate Surge Protective Devices (SPD) and external grounding shall be incorporated at a communications site in order to provide an adequate level of protection. See Chapter 4, “External Grounding (Earthing) and Bonding”, and Chapter 7, “Surge Protective Devices”, for details and requirements.



NOTE

This section provides a summary of internal bonding and grounding requirements for types of communications sites, based on the requirements of this chapter. This summary is not all inclusive; all applicable sections in this chapter **shall** be followed.

5.10.1 Bonding and Grounding Requirements for Stand-Alone Shelters

Stand-alone equipment shelters are normally located next to a communication tower or placed on top of a large building to house the communications system equipment. The following are the bonding and grounding requirements for stand-alone equipment shelter installations:

- Installation of a grounding electrode system as appropriate for the site as described in Chapter 4, “External Grounding (Earthing) and Bonding.”
- Grounding of the electrical service per local codes and bonding to the common grounding electrode system. See “Electrical Service Grounding and Entrance Point” on page 5-8 and Chapter 6, “Power Sources”, for more information.
- Bonding of all grounding electrode systems together as described in Chapter 4, “External Grounding (Earthing) and Bonding”, and in “Common Grounding (Earthing)” on page 5-6.
- Installation of a Primary Bonding Bar (PBB) as described in “Master Ground (Earth) Bus Bar or Primary Bonding Bar” on page 5-10 or an integrated panel as described in “Integrated Panels and Cable Entry Ports” on page 5-15.
- Installation of Secondary Bonding Bars (SBB) as applicable, as described in “Sub System Ground Bus Bar or Secondary Bonding Bar” on page 5-17.
- Installation of an Internal Perimeter Bonding Bus (IPBB), as described in “Internal Perimeter Bonding Bus Conductor” on page 5-56. See Figure 5-124 and Figure 5-125 for an IPBB example.
- Installation of equipment bonding bus conductors as described in “Equipment Bonding Bus Conductor” on page 5-49. See Figure 5-126 and Figure 5-127 for an example.
- Bonding of all ancillary support apparatus as described in “Ancillary Support Apparatus” on page 5-107.
- Bonding of all cable tray systems as described in “Cable Trays” on page 5-104.
- Bonding of equipment as described in “Equipment” on page 5-99.
- Bonding of cabinets and racks as described in “Cabinets and Racks” on page 5-102.
- Bonding of all power systems (for example, separately derived AC systems, generators and DC power systems) as described in “Equipment and Ancillary Support Apparatus Bonding” on page 5-84 and applicable subsections.
- Bonding of all surge protective devices as described in “Surge Protective Devices” on page 5-117.
- Bonding of telecommunications cable metallic shields as described in “Telecommunication Cable Metallic Shields” on page 5-122.

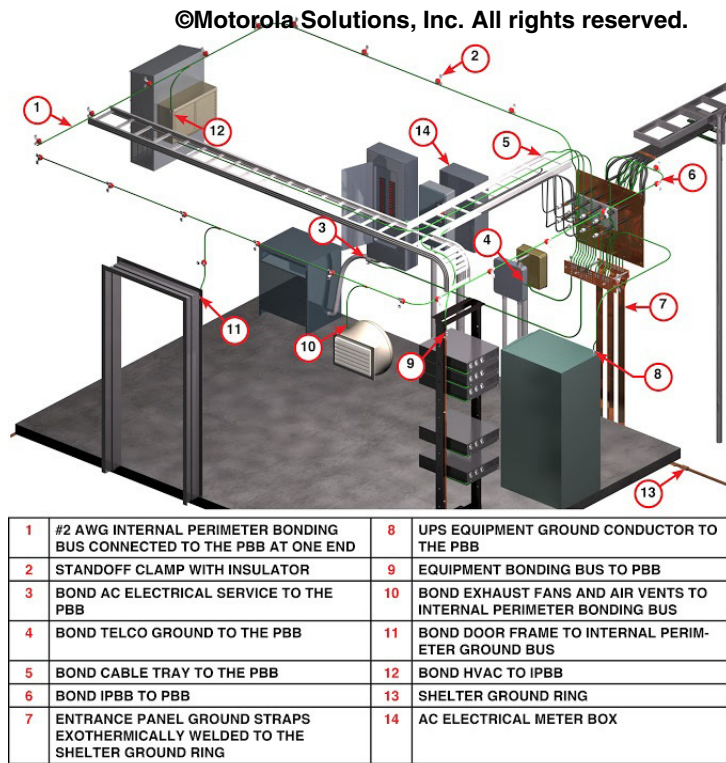

Figure 5-124 Example of Stand-Alone Equipment Shelter Bonding and Grounding

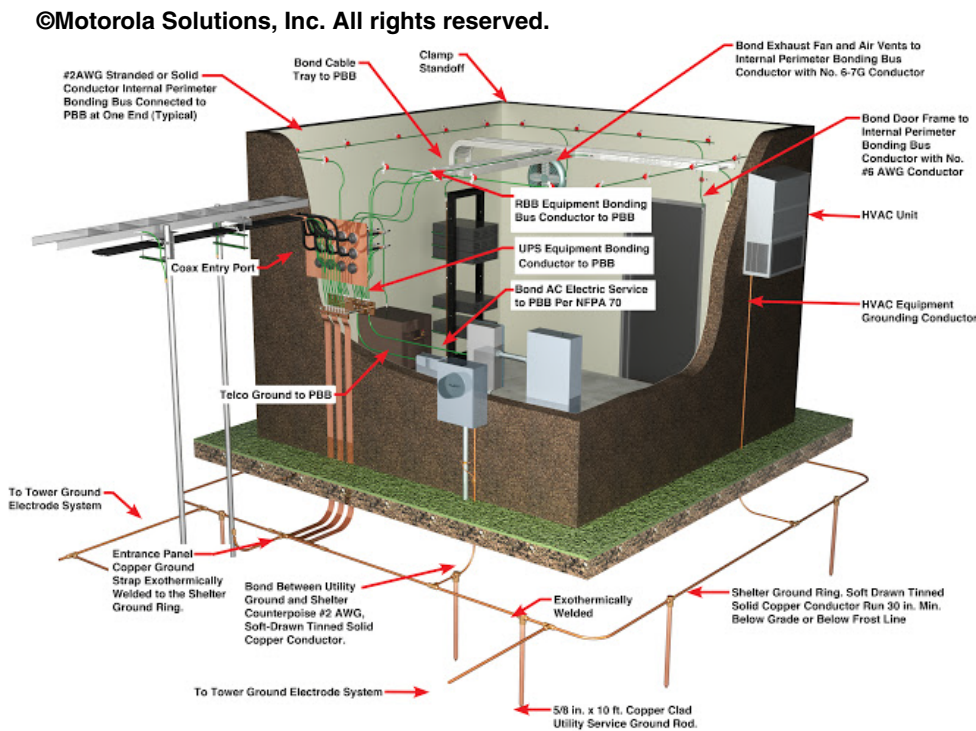

Figure 5-125 Example of Stand-Alone Equipment Shelter Bonding and Grounding

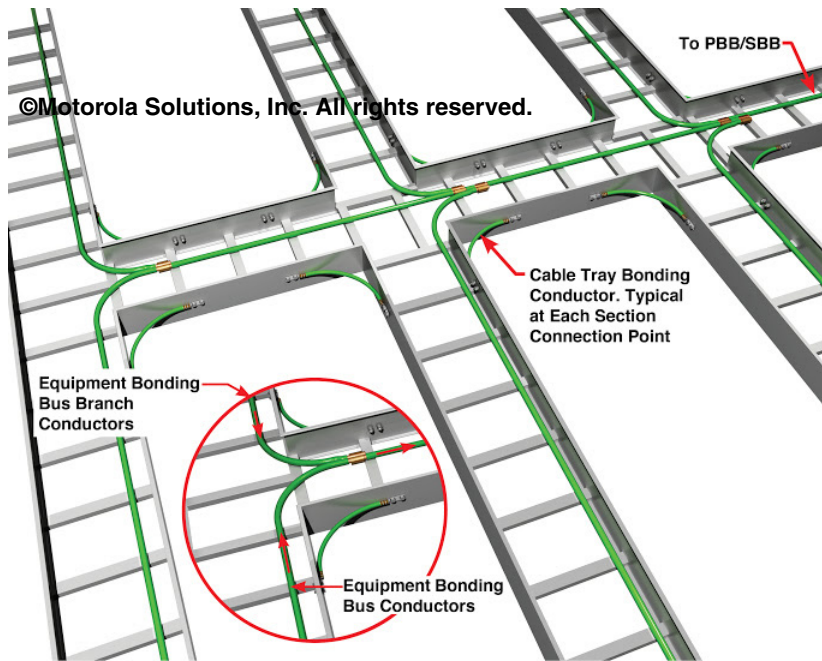

Figure 5-126 Example of Equipment Bonding Bus Conductors

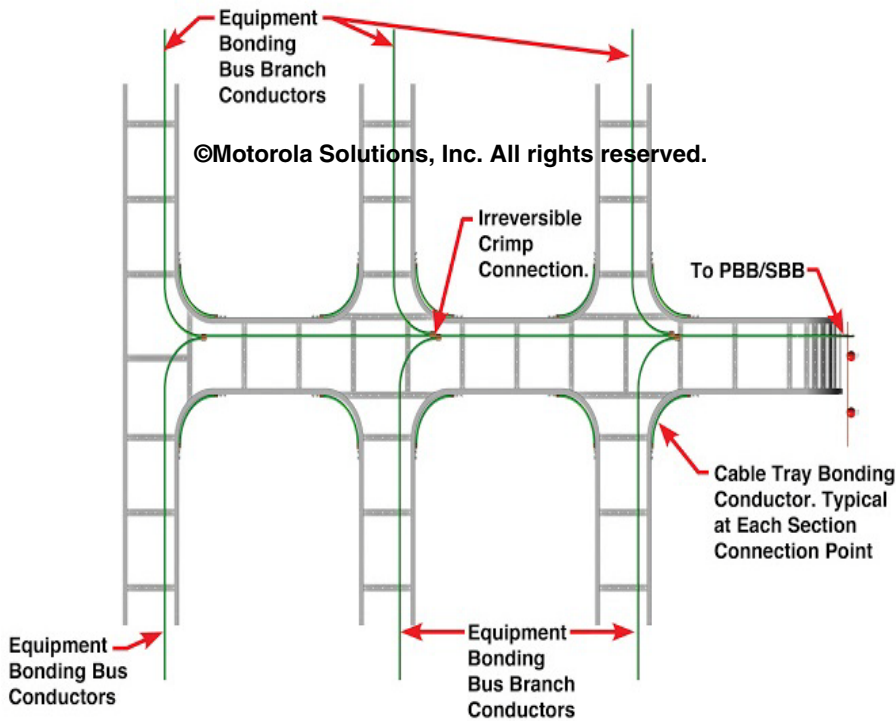

Figure 5-127 Example of Equipment Bonding Bus Conductors

5.10.2 Bonding and Grounding (Earthing) for Small Commercial Building Installations

A small commercial building installation is typically considered to be an installation in a commercial or office building where the communications equipment is located in the same general location as the electrical service entrance (common for small dispatch centers). See Figure 5-128 for an example.

This type of installation has the same general requirements as a stand-alone shelter once the Primary Bonding Bar (PBB) is established. The following PBB installations requirements apply:

- The PBB **shall** be installed in a location that minimizes conductor length between the PBB and electrical service ground (PBB grounding electrode conductor), while also allowing for convenient bonding of the electronic equipment, building structural metal, metallic water pipes and other grounding electrodes. See “Master Ground (Earth) Bus Bar or Primary Bonding Bar” on page 5-10 and Figure 5-128 for more information.
- The PBB grounding electrode conductor **shall** meet the requirements of “Primary Bonding Bar Grounding Electrode Conductor” on page 5-13.
- The PBB **shall** be used as the central bonding location for all other grounds at the site (for example: telco ground, building structural metal, water pipes, supplemental grounding electrodes and so on).
- The PBB may bond to the electrical service equipment ground (see Figure 5-129) or may bond directly to the building’s common grounding electrode system.
- Electrical panelboards in the telecommunications entrance facility/equipment room **shall** bond to the PBB as shown in Figure 5-128 (TIA-607-C). See “Ancillary Support Apparatus” on page 5-107.

©Motorola Solutions, Inc. All rights reserved.

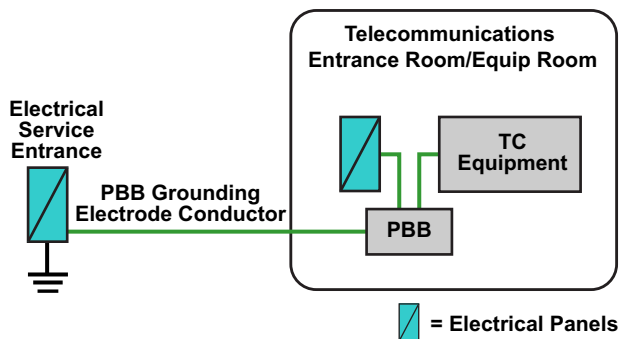

Figure 5-128 Example of Internal Bonding and Grounding System for Single-story Smaller Commercial Building

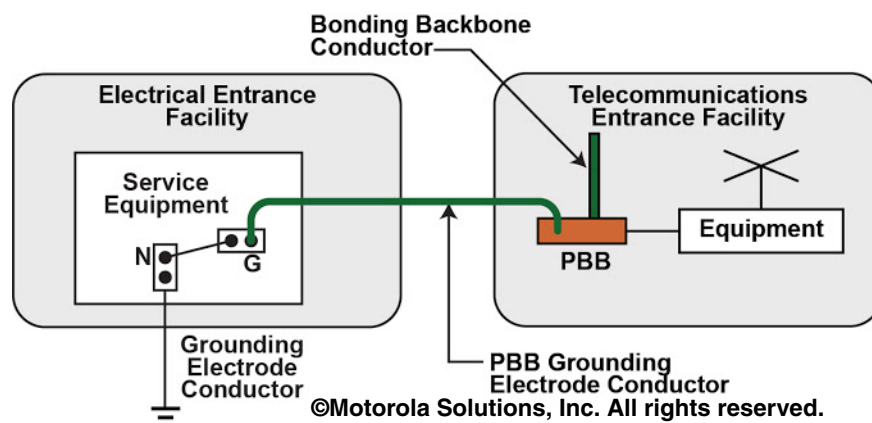

Figure 5-129 Example of Bonding to the Electrical Service (Power) Ground

**IMPORTANT**

Where structural metal is accessible and in the same room as the PBB, the PBB shall be bonded to structural metal using a conductor sized according to Table 5-3 (see TIA-607-C).

**NOTE**

If the existing grounding electrode system is unknown or cannot be verified (see Appendix D, “Grounding (Earthing) Electrode System Testing/Verification and Bonding Continuity Testing/Verification”), a supplemental grounding electrode system should be installed (see Chapter 4, “External Grounding (Earthing) and Bonding”, and Figure D-16). This supplemental grounding electrode system **shall** be bonded to the electrical service ground (typically at the PBB).

5.10.3 Bonding and Grounding (Earthing) for Large and Multi-Story Commercial Building Installations

A large commercial building installation is typically considered to be an installation in a commercial or office building where the communications equipment is located in a different location than the electrical service entrance (common for large dispatch centers) and/or multiple equipment rooms exist. This type of installation can be a single-story building (see Figure 5-130) or a multi-story building (see Figure 5-131).

Large and/or multi-story buildings require the installation of a bonding backbone as described in “Bonding Backbone and Bonding Backbone Conductor” on page 5-53. The bonding backbone interconnects all equipment room Secondary Bonding Bars (SBB) to the building Primary Bonding Bar (PBB). See Figure 5-130 and Figure 5-131.

The following are the bonding and grounding requirements for large and multi-story commercial buildings:

- The PBB **shall** be installed in a location that minimizes conductor length between the PBB and electrical service ground (PBB grounding electrode conductor), while also allowing for convenient bonding of the bonding backbone conductors, building structural metal, metallic water pipes and other grounding electrodes. See “Master Ground (Earth) Bus Bar or Primary Bonding Bar” on page 5-10 and Figure 5-130 and Figure 5-131 for more information.
- The PBB **shall** be bonded to the electrical service equipment (power) ground using a conductor of the same size or larger, as the bonding backbone conductor (TIA-607-C).
- Each equipment room **shall** contain an SBB. This SBB serves as the PBB for each respective equipment room.
- The SBB **shall** be installed as close as practicable to the panelboard serving that equipment room and **shall** be installed to maintain clearances required by applicable electrical codes (TIA-607-C, section 7.3.1).
- Where a panelboard for the equipment room is not installed in the same room or space as the SBB, that SBB should be located near the backbone cabling and associated terminations (TIA-607-C, section 7.3.1).
- Where a panelboard serving the equipment room is not located in the same room or space as the SBB, that SBB should be bonded to the panelboard that feeds the equipment room, using bonding conductors sized according to Table 5-4 (TIA-607-C, section 7.3.2).
- Bonding and grounding within each equipment room follows the general requirements summarized in “Bonding and Grounding Requirements for Stand-Alone Shelters” on page 5-124.
 - The PBB referenced in “Bonding and Grounding Requirements for Stand-Alone Shelters” on page 5-124 is now an SBB (bonded to a bonding backbone) that serves as the PBB for each equipment room.
- Electrical panelboards in each equipment room **shall** bond to that room’s respective SBB as shown in Figure 5-130 and Figure 5-131. See “Ancillary Support Apparatus” on page 5-107.
- All metallic pathways for telecommunications cabling located within the same room or space as the SBB **shall** be bonded to the SBB (TIA-607-C, section 7.3.2).

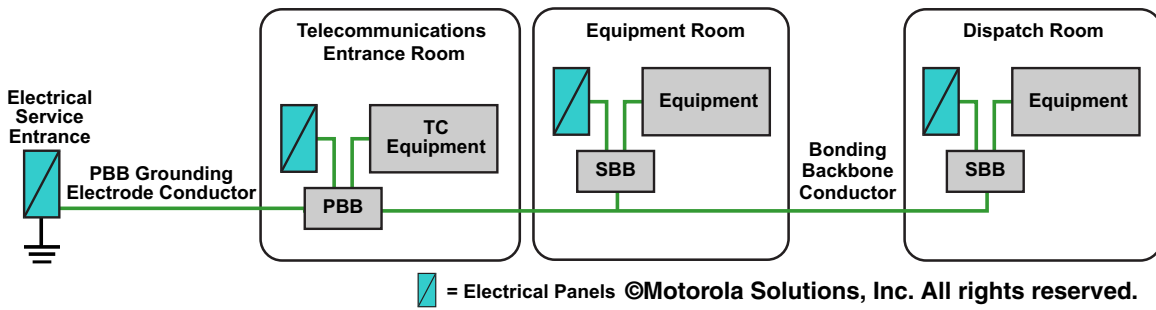

Figure 5-130 Example of Internal Bonding and Grounding System for Single-Story Large Commercial Building



IMPORTANT

The PBB grounding electrode conductor shall be the same size as or larger than the bonding backbone conductor (TIA-607-C).

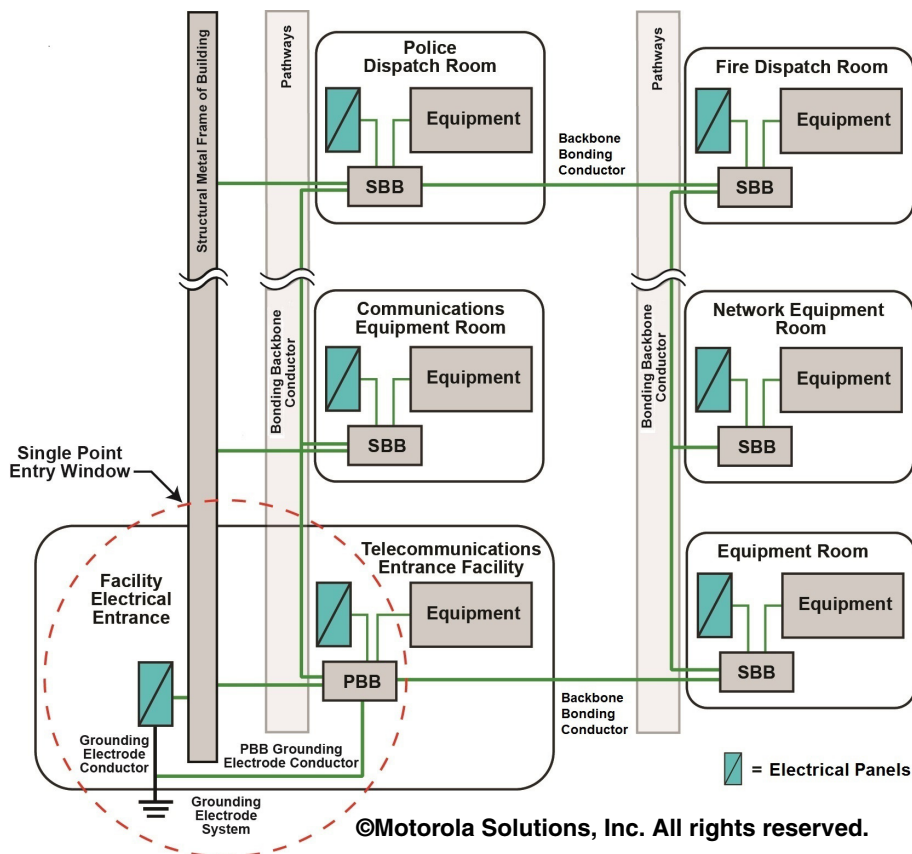

Figure 5-131 Example of Internal Bonding and Grounding System for Multi-Story Commercial Building

**NOTE**

Buildings or campuses with more than one electrical service entrance, each of which serves the communication system, require special design considerations that are beyond the scope of this document. Consultation with Motorola Solutions Engineering or with an engineering firm is recommended in these instances.

**IMPORTANT**

Concrete reinforcing steel, water piping systems, cable shields, metallic pathways and conduits shall not be used as a bonding backbone conductor (TIA-607-C, sections 6.3.5.1 and 7.5.4).

Where external antenna cables and other communications cables enter the building in a location other than the single point entry window, that point of entry **shall** be provided with an Entry Point Secondary Bonding Bar as described in “Secondary Bonding Bar Serving an Entry Point” on page 5-26.

5.10.4 Bonding and Grounding (Earthing) for Integrated and Rooftop Communication Sites

A communications site integrated within a high-rise building has the same general requirements as described for a multi-story building in “Bonding and Grounding (Earthing) for Large and Multi-Story Commercial Building Installations” on page 5-128. Use of structural metal as the bonding backbone conductor is preferred and is typically more practicable than the installation of a conductor (see Figure 5-132). See “Bonding Backbone and Bonding Backbone Conductor” on page 5-53 for more information. See Figure 5-133 and Figure 5-134 for examples of high-rise building installations.

©Motorola Solutions, Inc. All rights reserved.

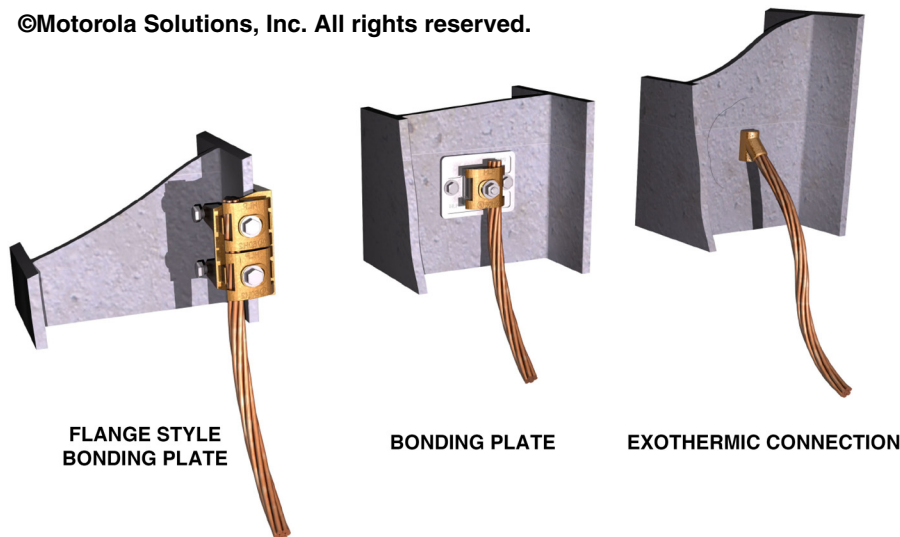

Figure 5-132 Examples of Acceptable Structural Building Steel Bonding Connections



Figure 5-133 Integrated Site Bonding When Building Steel Is Not Available



Figure 5-134 Integrated Site Bonding When Building Steel Is Available

A rooftop communications site is a communications shelter or building installed on a rooftop or a rooftop penthouse used as a communications equipment room. The rooftop communications shelter or building or penthouse equipment room **shall** contain an internal bonding and grounding system with all equipment bonded and grounded as described in this chapter and summarized above for integrated sites. The inside of the site is bonded and grounded as described in “Bonding and Grounding Requirements for Stand-Alone Shelters” on page 5-124.

The rooftop communications site internal bonding and grounding system and external ground bus bar (where applicable) **shall** be bonded to earth using methods described in “Rooftop Communications Sites” on page 4-134. See TIA-607-C, section C.2.6, for more information. See Figure 5-135 and Figure 5-136 for rooftop site examples.



IMPORTANT

Concrete reinforcing steel, water piping systems, cable shields, metallic pathways and conduits shall not be used as a bonding backbone conductor (TIA-607-C, sections 6.3.5.1 and 7.5.4).

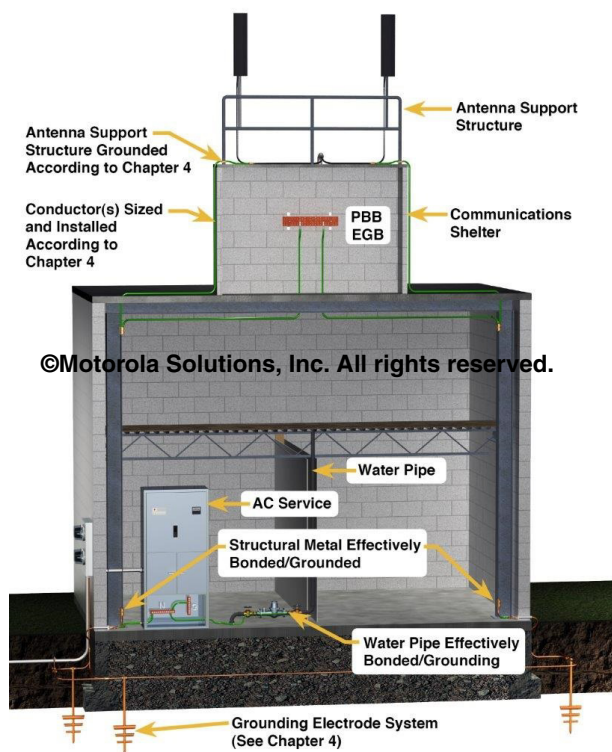

Figure 5-135 Rooftop Site Bonding When Building Steel Is Available

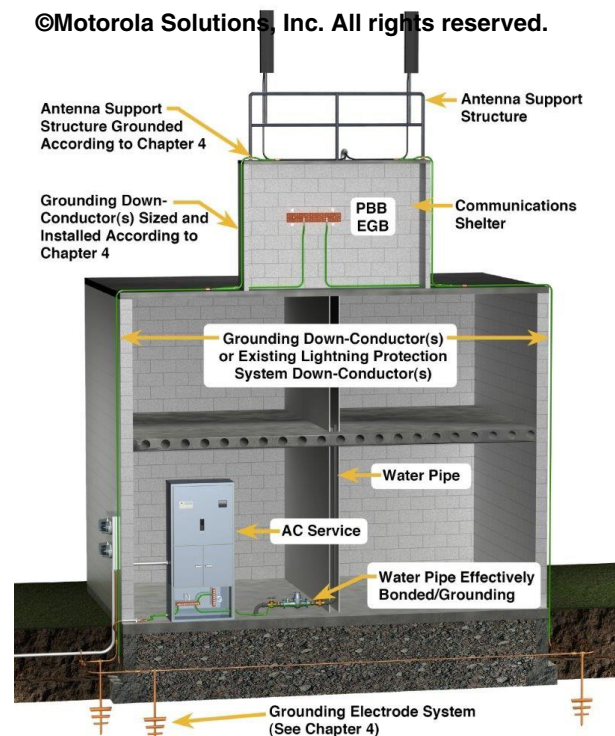

Figure 5-136 Rooftop Site Bonding When Building Steel Is Not Available

5.10.5 Bonding and Grounding (Earthing) for Dispatch Centers and Network Operator Positions

Equal potential (equipotential) bonding at the network operator position is essential in providing personnel safety and equipment reliability. A dispatch/network operator position often contains a headset, headset interface equipment and other electronic equipment such as consoles, computers, video displays, small emergency radios and work position furniture (see ATIS-0600321.2015, section 1). Work positions are frequently arranged in clusters within a dispatch room and the operator equipment is interconnected with other communication system equipment located throughout the building. In these instances, it is not only important to establish equipotential bonding at the operator position, it is also necessary to establish it between any adjacent operator positions. The ground potential **shall** also be equalized between any interconnected communication systems within the building that are fed by the same electrical service.

Electrical disturbances may appear at dispatch/network operator-type equipment positions arising from Electrostatic Discharge (ESD) or from sources that are internal or external to the building, such as lightning or AC power disturbances (see ATIS-0600321.2015, section 1).



IMPORTANT

All grounding electrodes at the site shall be bonded together as described in “Common Grounding (Earthing)” on page 5-6 and its subsections.

Dispatch centers (especially where co-located with a communications tower) require special protection considerations due to the critical nature of their operation and due to the inherent risk to personnel from lightning events. For optimum protection of a dispatch center, the following **shall** be followed:

- Site design recommendations given in “Design Considerations to Help Reduce Effects of Lightning” on page 2-16.
- External grounding (earthing) and bonding as defined in Chapter 4, “External Grounding (Earthing) and Bonding”.

- External grounding as defined in “Dispatch Centers Co-Located With Communications Towers” on page 4-122, if applicable.
- Surge protection as defined in Chapter 7, “Surge Protective Devices”.
- Electrostatic discharge (ESD) precautions as defined in Appendix C, “Protecting Against Electrostatic Discharge in Equipment Rooms and Dispatch Centers”.
- Internal bonding and grounding as defined in this chapter for the appropriate site type(s). See “Bonding and Grounding (Earthing) for Specific Site Types” on page 5-124 and appropriated subsections for details.
- Installation of a supplementary bonding network (bonding grid) in the dispatch room/area as described in “Supplementary Bonding Network or Bonding Grid” on page 5-59.
- Raised computer floor bonding as described in “Raised Computer Floor Bonding” on page 5-115 and applicable subsections.
- Equal potential (equipotential) bonding at the network operator position as described in “Equipotential Grounding (Earthing) of the Network Operator Position” on page 5-134 and associated subsections.

5.10.5.1 Equipotential Grounding (Earthing) of the Network Operator Position

Equal potential (equipotential) bonding at dispatch/network operator-type equipment positions should be integrated into the position equipment to the greatest extent practicable. This will largely reduce the need to place bonding conductors on a per installation basis. All furniture, telecommunications cable shields, data cable shields, and the AC electrical ground **shall** be bonded together at the position Secondary Bonding Bar (SBB) or within the equipment (see Figure 5-137). See ATIS-0600321.2015, section 7.

All dispatch/network operator equipment including, but not limited to, the items listed in this section, **shall** be effectively bonded to an Operator Position Secondary Bonding Bar (SBB) using methods described within this chapter (see Figure 5-138). See ATIS-0600321.2015 and the following subsections for additional information.

- Equipment supplied with a ground (earth) connection point
- Mounting rails or support brackets intended for mounting equipment on or within the furniture
- Metallic parts of network operator furniture
- Telecommunication cable shields
- Data cable shields
- Voltage limiting secondary surge protective devices
- AC Power ground

A Secondary Bonding Bar (SBB) **shall** be installed at the network operator position area (see Figure 5-138 for an example). If several network operator positions are arranged in a cluster, a single SBB may be shared at each cluster, provided the SBB is sized accordingly and equipment bonding conductor length restriction can be met. See ATIS-0600321.2015, section 7.1 for more information.



NOTE

An SBB at a network operator position may be referred to as a Position Bonding Terminal (PBT) in some standards.

Each network operator position SBB **shall** be bonded to internal bonding and grounding system as described in “Sub System Ground Bus Bar or Secondary Bonding Bar” on page 5-17 and applicable subsections. Network operator position SBB bonding may also be made to a bonding backbone as described in “Bonding Backbone and Bonding Backbone Conductor” on page 5-53 or to a bonding grid as described in “Supplementary Bonding Network or Bonding Grid” on page 5-59.



NOTE

For optimum equal potential (equipotential) bonding in a dispatch room or area, a bonding grid installed under the computer floor as described in “Supplementary Bonding Network or Bonding Grid” on page 5-59 is recommended. See Figure 5-139.

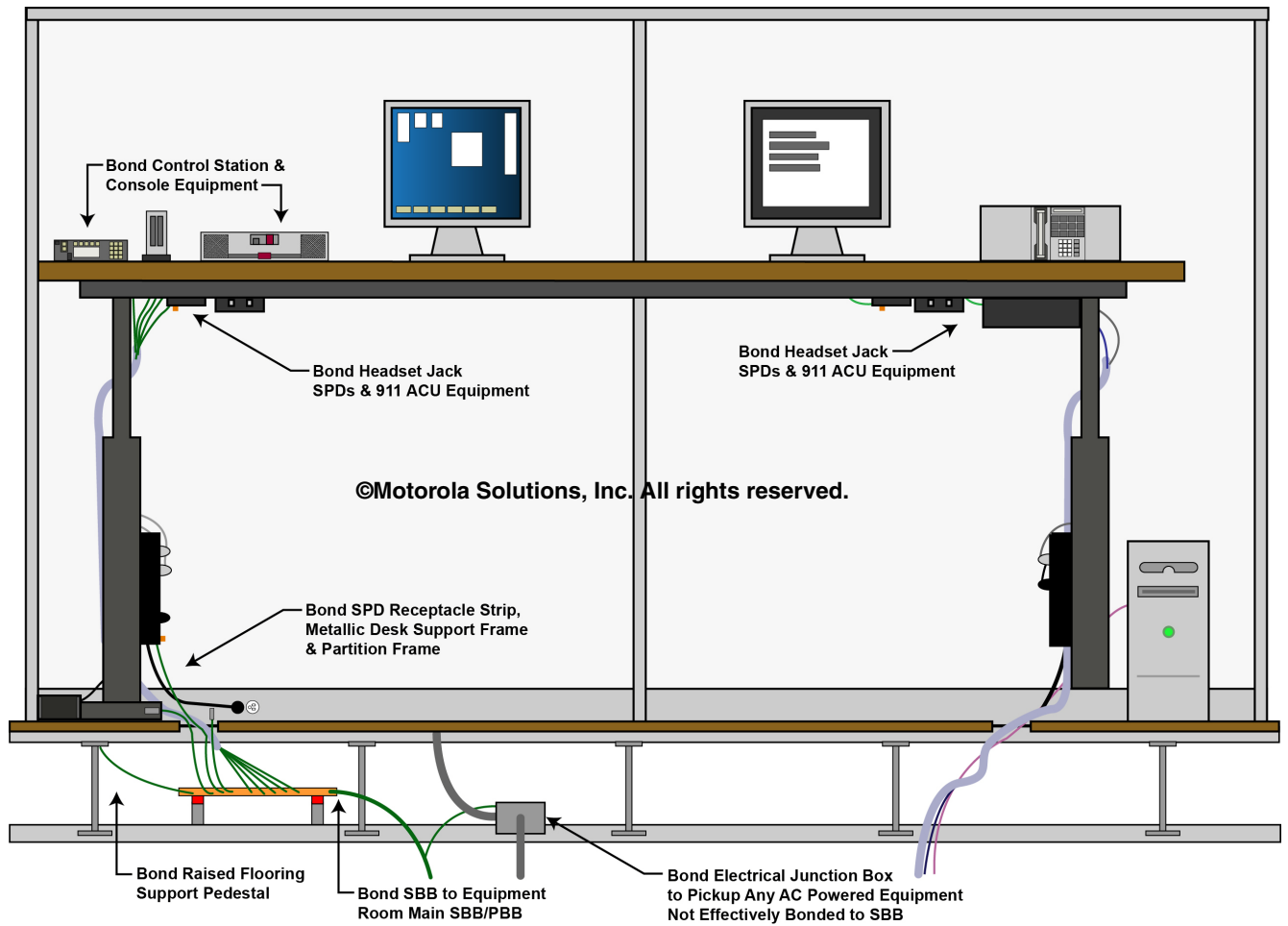

Figure 5-137 Example of Operator Position Bonding

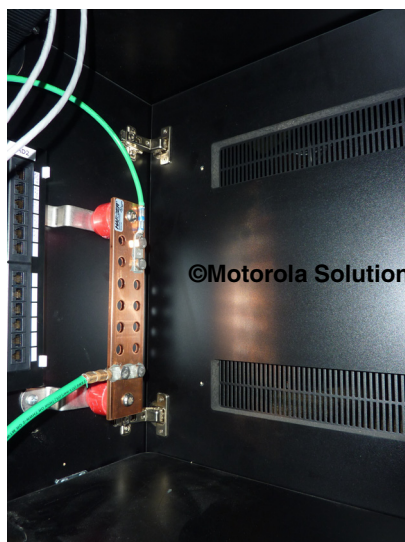

Figure 5-138 Example of Secondary Bonding Bar at Operator Position

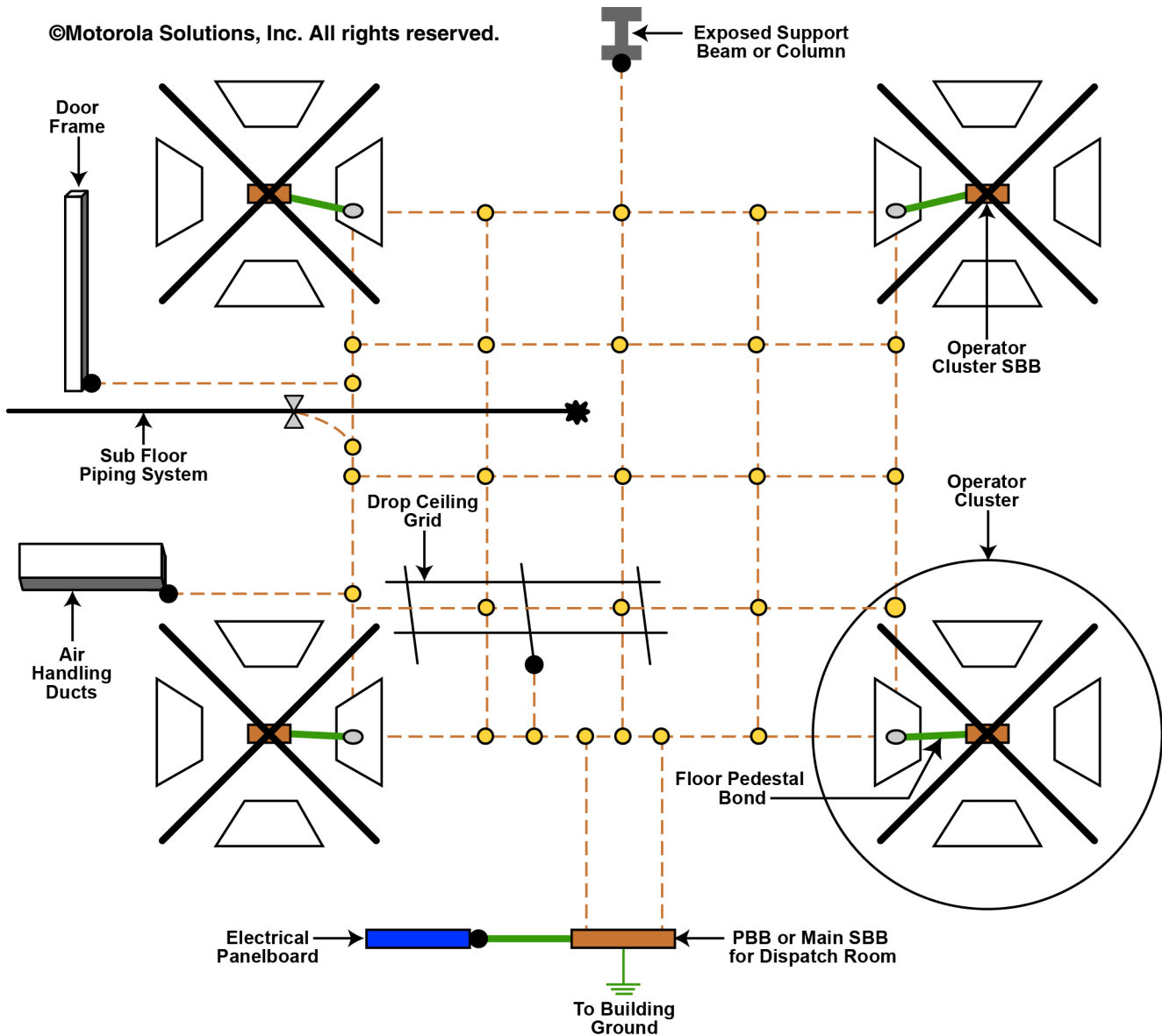

Figure 5-139 Example of Bonding Grid in Dispatch Area

A dispatch room or area may contain a main SBB to be used as a collection point for the operator position SBBs (see Figure 5-140). Where installed, the main SBB **shall** be located in a location that provides convenient bonding of all network operator position SBBs and provides the most direct path to the internal bonding and grounding system. The main SBB **shall** bond to the internal bonding and grounding system using conductors sized as described in this chapter (Table 5-3). Bonding conductors from the main SBB to the network operator position SBBs **shall** be sized according to Table 5-3 based on the length between the two bonding bars.

NOTE

A main Secondary Bonding Bar (SBB) used in a dispatch room/area is considered part of the bonding backbone. See “Bonding Backbone and Bonding Backbone Conductor” on page 5-53.

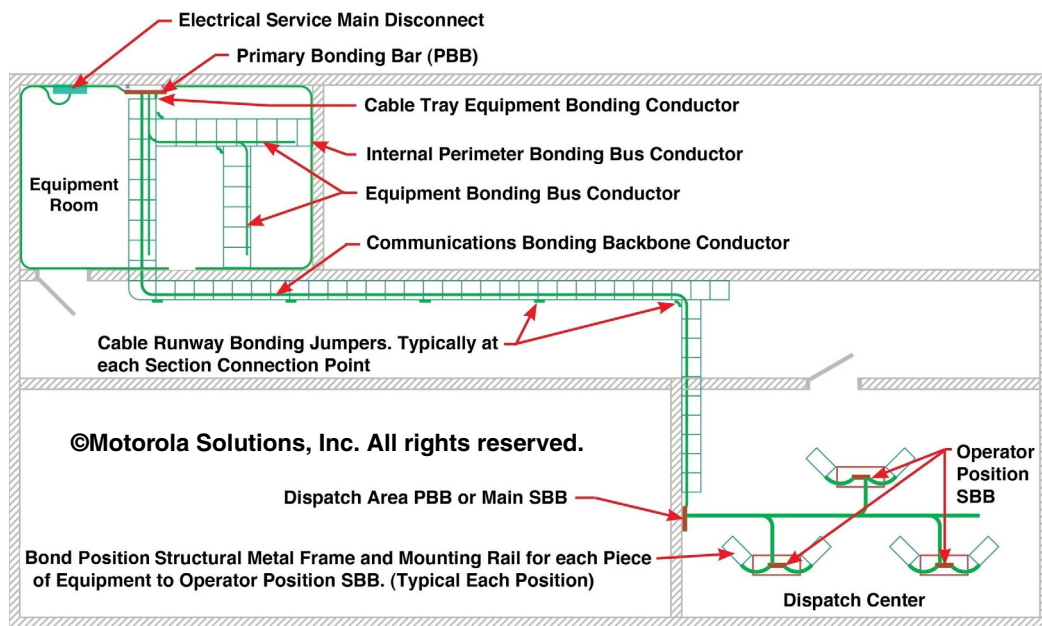

Figure 5-140 Example of Main Secondary Bonding Bar in Dispatch Area

5.10.5.1.1 Bonding of Equipment and Furniture at the Operator-Type Equipment Position

All metallic equipment enclosures, frames, chassis, mounting rails, operator position furniture (other than chairs) and other items with a designated bonding/grounding point **shall** be effectively bonded to the Operator Position SBB using bonding conductors as follows:

- 6 mm² csa (#10 AWG) for lengths not exceeding 3 m (10 ft).
- 16 mm² csa (#6 AWG) for lengths not exceeding 3.9 m (13 ft).
- If a longer length is required, the equipment bonding/grounding conductor **shall** be sized according to Table 5-4. Ensure the SBB is installed at the optimum location.
- See Figure 5-141 for an example.

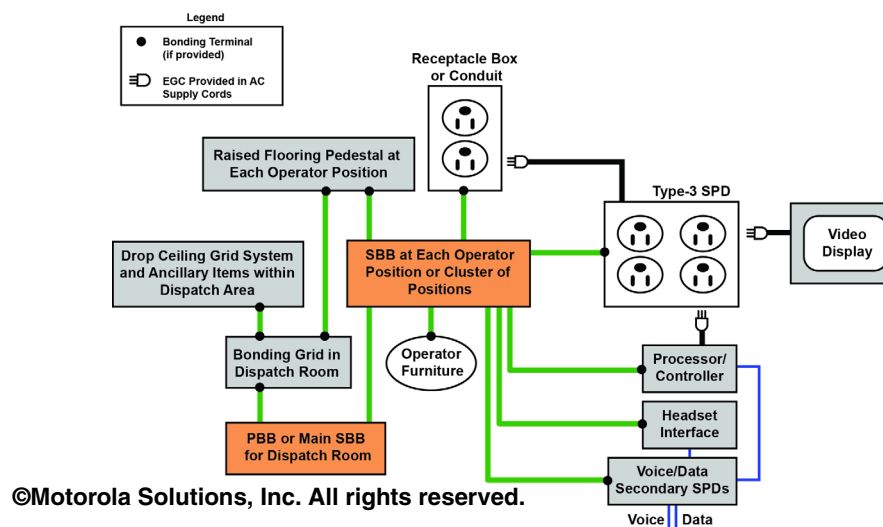

Figure 5-141 Example of Network Operator Position Bonding

5.10.5.1.2 Bonding to Power at the Operator-Type Equipment Position

Where AC power is present at a network operator position, the AC power receptacle housing(s), metallic conduit(s) or equipment grounding conductor(s) (EGC) **shall** bond to the Operator Position SBB using a bonding conductor as follows:

- 6 mm² csa (#10 AWG) for lengths not exceeding 1 m (3 ft)
- 16 mm² csa (#6 AWG) for lengths not exceeding 3.9 m (13 ft).
- If a longer length is required, the equipment bonding conductor **shall** be sized according to Table 5-4.

In addition, if a Power Distribution Unit (PDU) or Type 3 Surge Protective Device (SPD) is installed at the operator position, it **shall** be bonded to the SBB as described in this section or according to the manufacturer's recommendations.

The conduit or raceway serving the receptacle box **shall not** be relied upon as the sole AC equipment grounding conductor at the position. A separate, insulated AC equipment grounding conductor **shall** be run with the branch circuit supply conductors and **shall** be properly bonded to the metallic receptacle box, conduit or armored cable per the requirements of NFPA 70-2017. See Chapter 6, "Power Sources", and ATIS-0600321.2015 for more information.

The equipment grounding conductors of AC branch circuits serving network operator equipment positions **shall not** be electrically isolated from the building bonding and grounding network in any way. Because of the required bonding of the AC equipment grounding conductor to the SBB and the need for a single common ground potential, isolated ground receptacles (orange in color) **shall not** be used (see Figure 5-142) (ATIS-0600321.2015, section 7.3). See "Receptacles" on page 6-13 for more information.



©Motorola Solutions, Inc. All rights reserved.

Figure 5-142 Example of Unapproved Isolated Ground Receptacle (Orange Colored)

5.10.5.1.3 Bonding of Telecommunications Cable Metallic Members

Outer shields of telecommunication cables serving the network operator position or cluster of positions (to or from a different location) **shall** be bonded directly to the SBB or by using bonding conductors as follows:

- 6 mm² csa (#10 AWG) for lengths not exceeding 1.8 m (6 ft).
- 16 mm² csa (#6 AWG) for lengths not exceeding 3.9 m (13 ft).

The outer shield ground/bond is provided automatically where the cable connector contains a shield-to-chassis connection. See ATIS-0600321.2015, sections 7.2 and 7.5 for more information.

5.10.5.1.4 Bonding of Nearby Metallic Objects

Exposed metallic objects located within 2.4 m (8 ft) vertically or 1.5 m (5 ft) horizontally from the operator position **shall** be effectively bonded to the Operator Position Secondary Bonding Bar (SBB) or bonding grid, with a minimum 16 mm² csa (#6 AWG) bonding conductor of the shortest and straightest length practicable (see ATIS-0600321.2015, Figure 1 and section 7.6, for more information). Metallic objects include, but are not limited to, the following (may be above or below a raised flooring system):

- Building steel or structural metal

- Ventilation ducts
- Metallic plumbing
- Raised flooring system pedestal

At least one nearby raised flooring system pedestal **shall** be bonded to the Operator Position SBB. If the SBB serves more than one operator position, at least one raised flooring system pedestal near each operator position **shall** be bonded to the SBB.



NOTE

The floor pedestal bonding requirements described in this section are above and beyond the requirements described in “Raised Computer Floor Bonding” on page 5-115. If a nearby floor pedestal is already bonded to a bonding grid, a different nearby floor pedestal **shall** be bonded to the Operator Position SBB.

Other items, such as electrical panelboards, metallic water fountains, metallic plumbing, metallic ventilation ducts and other metallic ancillary support items, **shall** be bonded to the nearest bonding grid conductor or SBB, with a minimum 16 mm² csa (#6 AWG) copper conductor of the shortest length practicable.

5.10.5.1.5 Interposition Bonding

In order to improve interposition bonding of multi-cluster network operator-type equipment positions, a bonding grid as described in “Supplementary Bonding Network or Bonding Grid” on page 5-59 is recommended. Interposition bonding helps ensure an equal potential between different clusters. This is most important if an operator approaches a position in a neighboring cluster while connected to his or her own position. See ATIS-0600321.2015, section 7.7 for more information.

If a bonding grid is not installed, all Operator Position Secondary Bonding Bars (SBB) should be bonded together in a grid pattern, in addition to the SBB bonding to the area primary or main SBB. This is in addition to the existing bonding bus conductors that bond each Operator Position SBB to the main area SBB or Primary Bonding Bar (PBB). See Figure 5-143.

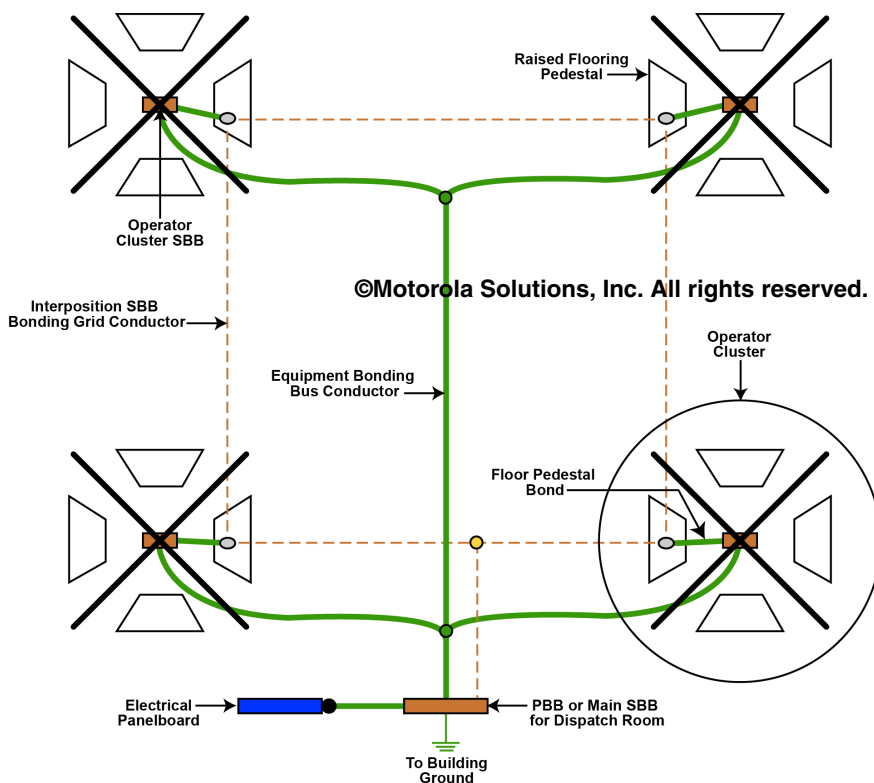

Figure 5-143 Example of Interposition Bonding

5.10.5.1.6 Surge Protective Devices

Surge Protective Devices (SPD) **shall** be present on all AC power, telephone and data communication cables at every network operator position or cluster as described in Chapter 7, “Surge Protective Devices”. Surge protective devices will help minimize voltages between communication conductors and conductive surfaces. Where SPDs are present, they **shall** be bonded directly to the SBB or by using bonding conductors as follows:

- Secondary SPDs for telephone circuits, data circuits and control circuits as described in “Secondary Surge Protective Devices” on page 5-120.
- AC power SPD as follows:
 - 6 mm² csa (#10 AWG) for lengths not exceeding 1 m (3 ft).
 - 16 mm² csa (#6 AWG) for lengths not exceeding 3.9 m (13 ft).

5.11 Testing the Internal Bonding and Grounding (Earthing) System

The internal bonding and grounding system **shall** be tested as described in the following subsections.

5.11.1 Bonding Continuity

The internal bonding and grounding system continuity **shall** be tested as described in “Clamp-on Ohmmeter Bonding Continuity Testing” on page D-28. Bonding continuity **shall** be tested at the Primary Bonding Bar (PBB), Secondary Bonding Bars (SBB), Rack Bonding Bars (RBB), bonding bus conductors, and so on. See Figure 5-144 for a clamp-on ohmmeter example.



Figure 5-144 Example of Clamp-on Ammeter/Ohmmeter

5.11.2 Current Testing

The internal bonding and grounding system **shall** be tested for objectionable current (AC and DC). As indicated in “Glossary” on page 1-13, objectionable current is defined as: “Any current flow over conductors not designed to normally carry current. For example, an equipment grounding conductor is not intended to carry current, except during a fault condition.”

Per NFPA 70-2017, Article 250.6, “The grounding of electrical systems, circuit conductors, surge arrestors, surge protective devices and conductive normally non-current-carrying metal parts of equipment **shall** be installed and arranged in a manner that will prevent objectionable current.”

Objectionable current (especially objectionable neutral current) can lead to the following:

- Shock hazard
- Fire hazard
- Improper operation of electronic equipment (due to the EME field created by the objectionable current)

See the Mike Holt Enterprises, Inc. (www.MikeHolt.com) publication “Understanding the National Electrical Code,” section 250.6, for more information.

Identifying and isolating objectionable current (AC or DC) may require a power quality engineer and/or certified R56 Auditor Subject Matter Expert (SME).

5.11.2.1 DC Current Testing

To help prevent objectionable DC current on the internal bonding and grounding system, DC systems **shall** be configured as an Isolated Ground-type System as described in “DC Power Systems” on page 5-89 and “Installation Requirements for Isolated Ground-Type System” on page 5-90. In this configuration and under normal operating conditions, the internal bonding and grounding system does not carry DC current. Any DC current on the internal bonding and grounding system will be the result of one or more of the following: a fault condition, incorrectly configured equipment (for example, not configured for isolated grounding), faulty equipment, improperly installed equipment and so on.



IMPORTANT

Many DC Power Distribution Units (PDU) are jumper configurable for the type of grounding used. Ensure the PDU is jumpered/configured for isolated grounding.

Where a DC power system is installed, the internal bonding and grounding system **shall** be tested for objectionable DC current after all equipment is installed. Testing **shall** be completed using an appropriate clamp-on DC ammeter (see Figure 5-145). Typically, the easiest location to test for objectionable DC current is on the DC System Bonding Jumper (see “DC Power Systems” on page 5-89) near the DC power system. If any significant DC current is measured, the source **shall** be identified and corrected as appropriate.

Motorola Solutions recommends 50 mA as the threshold for significant objectionable DC current. However, the site owner **shall** get a final determination from the Authority Having Jurisdiction (AHJ).



©Motorola Solutions, Inc. All rights reserved.

Figure 5-145 Example of Clamp-on AC/DC Ammeter

5.11.2.2 AC Current Testing

The internal bonding and grounding system **shall** be tested for objectionable AC current after all equipment is installed. Testing **shall** be completed using an appropriate clamp-on AC ammeter (see Figure 5-144, Figure 5-145 and Figure 5-146). Typically, the easiest location to test for objectionable AC current is where the internal bonding and grounding system bonds to the Primary Bonding Bar (PBB). Several other locations **shall** also be tested, such as near each Rack Bonding Bar (RBB) and Secondary Bonding Bar (SBB).

In addition to testing the internal bonding and grounding system, electrical metallic conduits at the site **shall** be tested for current using an appropriate clamp-on AC ammeter. Testing a metallic conduit may require a clamp-on meter with a large jaw (see Figure 5-146). The typical test locations are at the panelboard where the conduit terminates and/or where the conduit goes around a corner (corners provide more room for the meter jaws).

Measured currents in excess of 3 A usually indicate faulty wiring (for example, improper neutral-ground bond or multiple neutral-ground bonds). Measured current up to approximately 300 mA may be the result of faulty equipment (for example, a faulty device or component leaking current to ground); in these cases, troubleshooting to isolate a specific faulty piece of equipment is required. If any significant AC current is measured, the source **shall** be identified and corrected as appropriate.

Motorola Solutions recommends 500 mA as the total site threshold for significant objectionable AC current, but only after completing the troubleshooting as described in the previous paragraph. However, the site owner **shall** get a final determination from the Authority Having Jurisdiction (AHJ).



© Motorola Solutions, Inc. All rights reserved.

Figure 5-146 Example of Large Jaw Clamp-on AC/DC Ammeter

This chapter describes various types of power systems that are used for communications sites. It also specifies requirements for various types of power systems that are typically used at a communication site. The following topics are included:

- “Safety for Power Sources” on page 6-1
- “AC Power” on page 6-2
- “Power Quality” on page 6-18
- “Rectifier/DC Power Systems” on page 6-25
- “Uninterruptible Power Supplies” on page 6-28
- “Alternate Power Sources” on page 6-29
- “Battery Systems” on page 6-31
- “Standby Generator Systems” on page 6-38
- “Generator Output and Derating Considerations” on page 6-38

6.1 Safety for Power Sources



NOTE

NFPA 70 is also known as the *National Electrical Code*[®] or *NEC*[®]. NFPA 70E is known as the Standard for Electrical Safety in the Workplace.

The following safety requirements **shall** be observed:

- Work practices that help ensure safety **shall** be observed while performing all electrical work. Electrical safety practices required by, but not limited to, OSHA, NFPA 70E, NFPA 70, BOCA and local codes **shall** be observed.
- All safety Cautions and Warning in the chapter **shall** be observed.



WARNING

Only qualified personnel shall open an electrical panel. Lethal voltages may be present.



WARNING

Batteries used for powering equipment pose safety risks. Always use appropriate caution when working with and around batteries. Follow all battery manufacturer safety recommendations.

6.1.1 Lockout/Tagout

On all power systems (AC or DC), a provision **shall** be present to lockout and tagout any circuit to help ensure the circuit is safe to work on. See NFPA 70E, OSHA 29 CFR 1910.147 (in the U.S.A.) and/or the Authority Having Jurisdiction (AHJ) for additional information. See Figure 6-1.



Figure 6-1 Proper Tagout of Circuit

6.2 AC Power

All AC power systems **shall** be designed, installed and maintained in accordance with jurisdictional standards and regulations.

All site power loading **shall** be determined for initial equipment installation and future expansion. The determined loads at various locations throughout the site **shall** then be factored into the site electrical design.

Continuous load **shall not** exceed 80% of the electrical system, (wire, panelboard, breakers and service rating). Using this standard allows all participants in site design (electric power company, prefabricated shelter vendor, UPS vendor, generator vendor, and so on) to ensure that the power capacity supplied to the communications site is adequate.



NOTE

NFPA 70-2017 defines a continuous load as a load where the maximum current is expected to continue for three (3) hours or more.

Minimum acceptable service for US installations is typically 100 amps @ 120/240 VAC (or 120/208 VAC). A 200 amp (or larger) service may be required for existing/future loads or for additional circuit breaker positions. Other service parameters may be applicable for nondomestic installations.

Sizing of AC power loads is critical in calculating supply capacity. Typical power needs are:

- HVAC system (including redundant units). Most sites consisting of shelters will not be continuously occupied. In such cases, the service personnel heat load need not be considered.
- Room lights and possible outdoor security lighting

**NOTE**

A standby generator may be required for continuity of service at sites where tower lighting is required to meet FAA (or equivalent) requirements.

- Tower lighting. Some tower lighting systems may require additional power capacity (strobes, multiple fixtures, and so on).
- Number of dedicated circuits for major pieces of equipment, including isolated equipment.
- Battery chargers
- Uninterruptible Power Supply (UPS) devices
- Equipment powered by rectifier systems (-48 VDC or similar)
- Utility receptacles. The number of utility receptacles required at a site is determined based on the size of the equipment room or shelter.
- The AC electrical power requirements of the communications room when all transmitters are simultaneously keyed **shall** be considered (for additional information, see NFPA 70-2017, Articles 220 and 310.15).
- Planned future expansion
- Consideration of unusual maximum continuous loads (such as trunked system failsoft operation).

6.2.1 Critical Operations Power Systems (COPS)

6.2.1.1 COPS Definitions

Critical Operations Power Systems (COPS): Power systems for facilities or parts of facilities that require continuous operation for the reason of public safety, emergency management, national security or business continuity (NFPA 70-2017, Article 708.2).

Designated Critical Operations Areas (DCOA): Areas within a facility or site designated as requiring critical operations power (NFPA 70-2017, Article 708.2).

Supervisory Control and Data Acquisition (SCADA): An electronic system that provides monitoring and controls for the operation of the critical operations power system. This can include the fire alarm system, security system, control of the HVAC, the start/stop/monitoring of the power supplies and electrical distribution system, annunciation and communications equipment to emergency personnel, facility occupants and remote operators (NFPA 70-2017, Article 708.2).

6.2.1.2 COPS Requirements

NFPA 70-2017, Article 708.1, Critical Operations Power Systems (COPS) Scope, states the following:

“The provisions of this Article apply to the installation, operation, monitoring, control and maintenance of the portions of the premises wiring system intended to supply, distribute and control electricity to designated critical operations areas (DCOA) in the event of disruption to elements of the normal system.

Critical operations power systems are those systems so classed by municipal, state, federal or other codes by any governmental agency having jurisdiction or by facility engineering documentation establishing the necessity for such a system. These systems include but are not limited to power systems, HVAC, fire alarm, security, communications and signaling for designated critical operations areas.”

NFPA 70-2017, Article 708.1 Informational Note 1 states the following:

“Critical operations power systems are generally installed in vital infrastructure facilities that, if destroyed or incapacitated, would disrupt national security, the economy, public health or safety; and where enhanced electrical infrastructure for continuity of operation has been deemed necessary by governmental authority.”

The 2017 NEC® Handbook (ISBN 1455912841) further explains:

“Article 708 addresses homeland security issues for facilities that are 'mission critical.' These requirements go beyond those of Article 700, in that these electrical systems must continue to operate during the full duration of an emergency and beyond. Examples of facilities that would use a critical operations power system include police stations, fire stations and hospitals. It may not include every one of these facilities within an area. Only facilities that are designated as critical because power must operate continuously with a robust power supply would be included.”



NOTE

Article 708 was added to the 2008 edition of NFPA 70.

At a high level, the following are some of the requirements that, if required to be addressed, could add significant cost to the project:

- A SCADA system that would provide monitoring and controls of the COPS.
- Conducting a documented risk assessment of the COPS including identifying any hazards.
- Developing a mitigation strategy.
- Physical security.
- Periodically testing of the system with written records that are compared to the initial testing.
- Independent wiring circuits/conduits.
- Electrical systems located in spaces with two-hour fire rating.
- Fiber optic cable requirement for inter-building connections.
- Provisions for a second generator hook-up, separate generator automatic transfer switch, and so on.

Motorola Solutions does not directly require a design to the COPS standards for powering two-way radio/communications systems. The Authority Having Jurisdiction and/or the end-user (customer) will set this requirement. New construction **shall** follow the COPS requirements as determined by the Authority Having Jurisdiction.

6.2.2 Electrical Service

The power company typically provides the service to the meter in underground installations and to the weatherhead in overhead installations. Depending on the scope of work, all wiring after the meter typically is the responsibility of the customer. Primary metering (high voltage) may be an exception. It is important to note the demarcation point used by the power company serving the region where the site is being constructed. This location affects installation costs.

The following requirements **shall** be observed when specifying and installing electrical service to the site building:

- See “Safety for Power Sources” on page 6-1 for general safety requirements.
- Throughout the US, the local buried utility locator service **shall** be contacted before excavating. In other countries, the local utility **shall** be consulted to obtain buried utility location service.



WARNING

Failure to properly locate buried utilities can pose hazards to personnel. Failure to comply with regulations regarding buried utilities can result in penalties.

- Electrical installation work **shall** be carried out in accordance with the current edition of NFPA 70 and local codes. Where required, only a qualified and licensed electrical contractor **shall** be used for all electrical installations.
- Underground and above ground service entrance conductors **shall** be protected from physical damage (see NFPA 70-2017, Article 230.50 and 300.5, for additional information).
- The service entrance conductor may be a material other than copper if permitted by local codes.

- The site electric meter **shall** be located where it is visible and accessible to power company meter readers and **shall** comply with all applicable codes and/or power company requirements.
- Meter access by power company personnel should be considered when determining meter location (especially where a fence is involved). See NFPA 70-2017, Article 110 and Article 230, for details regarding locations and service conductors.
- A fused disconnect **shall** always be installed before all other panels and equipment, including a generator transfer switch. See NFPA 70-2017, Article 445.18, for additional information.
- For a stand-alone equipment shelter, the main disconnect **shall** be located on the same wall as the coaxial cable entry port, the telephone entry point and the Primary Bonding Bar (PBB). If it is not practicable to locate these components on the same wall, then these components **shall** be located on an adjacent wall as close together as practicable. See IEEE 1100-2005, section 8.3.2.1.2, for additional information.
- The main bonding jumper **shall** be installed between the neutral bus and the ground bus within the main service disconnect. This is to ensure an effective low-impedance neutral-to-ground bond connection (so ground faults do not leave metallic objects energized). See NFPA 70-2017, Article 250.24(B), for additional information.
- Self-tapping or sheet metal type screws **shall not** be used for attaching ground or grounding conductor to any surface. See NFPA 70-2017, Article 250.8, for additional information.
- Paint, enamel, lacquer or other nonconductive coatings **shall** be removed from threads and surface areas where connections are made. See NFPA 70-2017, Article 250.12, for additional information.

6.2.2.1 Main Disconnect for Separately Derived System Feeding Equipment Room

The Main Disconnect may not be located in the same building as the equipment (a meter farm at a tower site, for example). This makes the panel in the building with the equipment a subpanel, not the main disconnect.

At all sites, there is either or both a main service disconnect and a fused disconnect. A main service disconnect may be located at a meter location away from the building. A main disconnect located within the shelter, equipment room or area may be fed by a feeder circuit originating at a main service disconnect located in an electrical room in a different location in the building or even a separate building. Typically, the neutral and ground conductors are bonded in the main service disconnect. Where the main service disconnect is located remotely from the equipment room or area, a separately derived system should be installed in the equipment room. See NFPA 70-2017, Articles 250.30 and 250.32, and “Location of Neutral-Ground Bond” on page 6-5 for additional information.

One of the reasons for the separately derived system is to reestablish the neutral-ground bond, thereby improving power quality (see “Power Quality” on page 6-18) and the effectiveness of normal mode suppression (see Chapter 7, “Surge Protective Devices”). See “Location of Neutral-Ground Bond” on page 6-5 for additional information.

6.2.3 Location of Neutral-Ground Bond

The neutral-ground bond is usually found at the main disconnect panel (first service disconnect). Unless otherwise permitted, there **shall** be only one neutral-ground bond (NFPA 70-2017). Additional neutral-ground bonds may be permitted, but only in the case of a separately derived system.



WARNING

Except in the case of a separately derived system, more than one neutral-ground bond can result in neutral current (Objectionable Current) flowing on the equipment grounding conductors, metallic conduits and/or metal parts of the building, resulting in an electrocution and/or fire hazard.



IMPORTANT

Objectionable (neutral) current flowing on metal parts of the electrical system and/or metal parts of the building can create electromagnetic fields (EMF). This EMF can result in operational problems or failure in some sensitive electronic equipment.

For the proper performance of electronic equipment, the voltage (or noise) between the neutral and ground conductors at the equipment **shall** be no more than 2V p-p (0.7 Vrms) (see “Power Quality” on page 6-18). Where the disconnecting means of the electrical service (therefore neutral-ground bond) is remotely located to the site, the voltage (or noise) developed between neutral and ground may cause equipment to malfunction, especially during a ground potential rise at the site. For the optimum performance of a Surge Protective Device (SPD) installed at the AC distribution panelboard, the neutral-ground bond must be near the SPD in order for the SPD to effectively redirect unwanted energies on the AC power conductors safely to the site grounding (earthing) electrode system.

6.2.3.1 Remote Radio Shelter with Power Supplied from Other Building

Where a remote radio shelter is supplied power from another building, a neutral-ground bond **shall not** be re-established at the remote radio shelter without the use of an isolation transformer or other approved separately derived system. See NFPA 70-2017 for more information.

Where the neutral-ground bond is located more than 15.25 m (50 ft) away from the remote radio shelter, Motorola Solutions recommends an isolation transformer be installed as close as practicable to the remote radio shelter. The distance recommendation **shall** consider conductor length from the neutral-ground bond to the remote radio shelter distribution panel. An isolation transformer installed near the remote radio shelter may also be required in order to reduce neutral-to-ground voltage/noise at the equipment to an acceptable level, even if the distance is closer than 15.25 m (50 ft). See “Power Quality” on page 6-18 for more information.

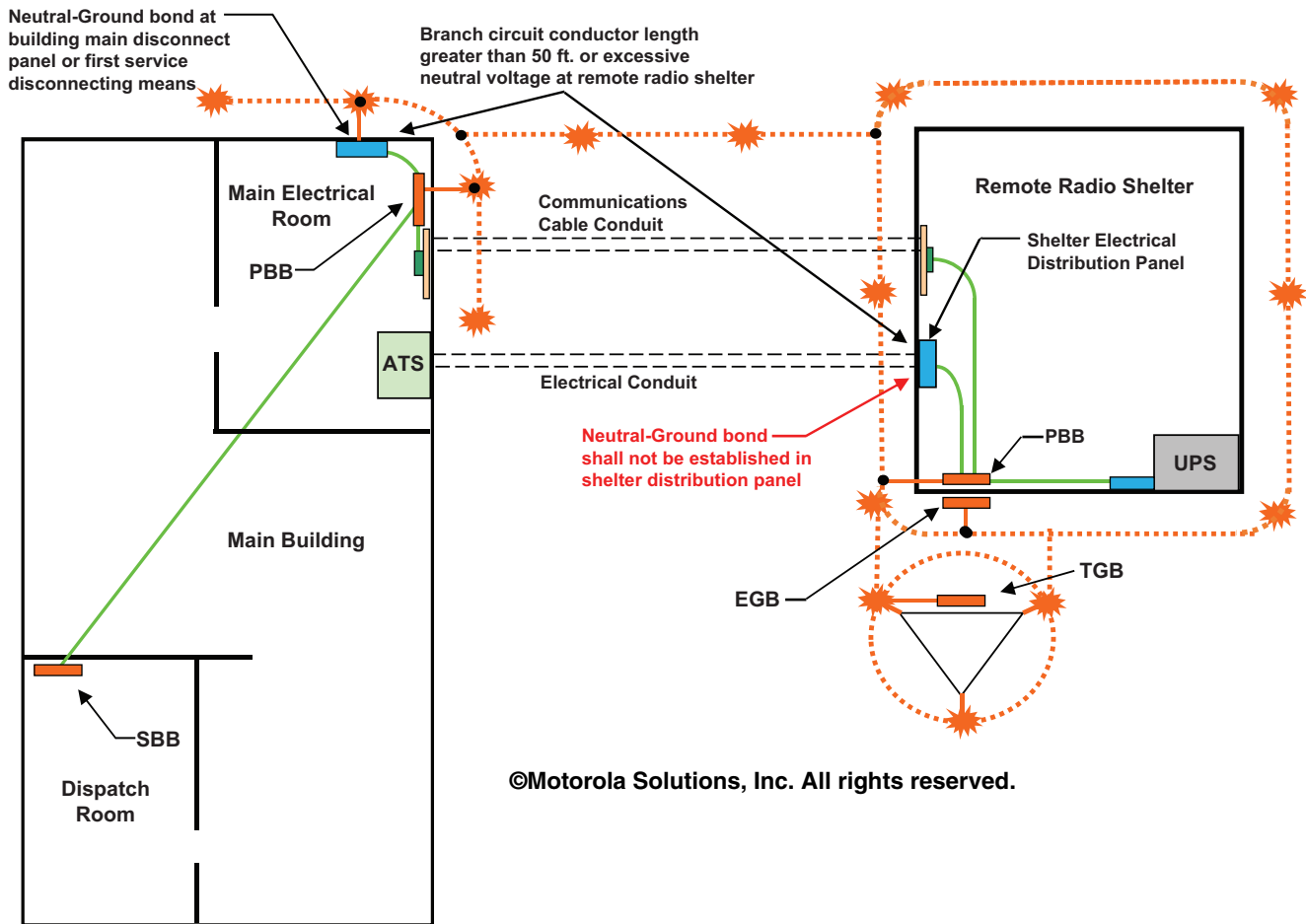

Figure 6-2 Remote Radio Shelter Less Than or Equal to 50 Feet From Main Disconnect

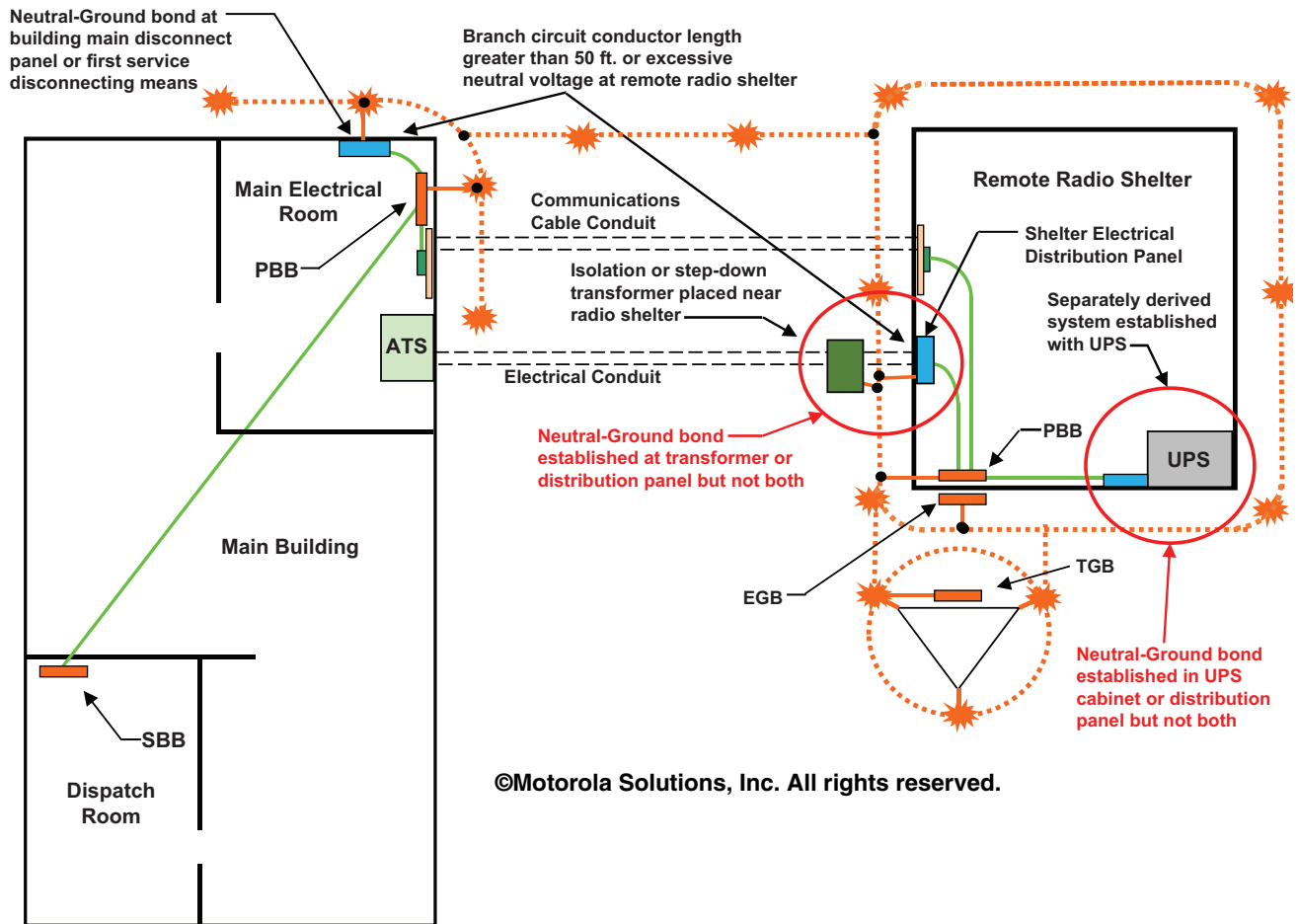

Figure 6-3 Remote Radio Shelter More Than 50 Feet From Main Disconnect

6.2.3.2 Larger Building

In larger buildings where the neutral-ground bond is located far away from the equipment room, an isolation transformer installed near the equipment room may be required in order to reduce neutral-to-ground voltage/noise at the equipment to an acceptable level. This configuration re-establishes the neutral-ground bond near the electronic equipment, thereby reducing neutral-to-ground voltage/noise. See “Power Quality” on page 6-18 for more information.

6.2.4 Separately Derived Systems Using Transformers

Communications site AC power can also be supplied by a transformer (also known as an isolation, step-down or step-up transformer). Separately derived transformers are typically used to step down three-phase 277/480 VAC service to standard commercial 120/208 VAC service.

To improve the effectiveness of line-to-neutral (normal mode) surge suppression and to reduce neutral-to-ground voltage/noise, the transformer is used to create a separately derived system where the neutral and ground conductors **shall** be bonded together within the transformer or within the first disconnect after the transformer and bonded to the building’s common grounding electrode system (see NFPA 70-2017, Article 250.30, for additional information.) See “Separately Derived AC Systems” on page 5-84.

6.2.5 Interior Electric

The following requirements **shall** be observed when specifying and installing interior electrical service:

- All interior wiring and electrical equipment installation **shall** comply with local jurisdictional codes, such as C22.1, or NFPA 70.
- All panelboards and switch boards **shall** display signage and placarding per NFPA 70-2017, Articles 110.22 and 408.4, and applicable local codes.
- Power panels, load centers and breaker boxes **shall** be identified using distinctive placarding/labeling identifying their purpose and location of the main service disconnect. See NFPA 70-2017, Articles 110.22 and 408.4, for additional information.
- Access and Working Space **shall** be provided and maintained about all electrical equipment to permit ready and safe operation and maintenance of such equipment (NFPA 70-2017, Article 110.26). See Figure 6-4.
 - **Depth of Working Space:** The minimum depth of the working space in front of electrical panels utilizing voltages of 1000 VAC or less **shall** be 914 mm (36 in.) according to NFPA 70-2017, Article 110.26.
 - **Width of Working Space:** The minimum width of the working space in front of electrical panels utilizing voltages of 1000 VAC or less **shall** be the width of the equipment or 762 mm (30 in.), whichever is greater, according to NFPA 70-2017, Article 110.26.
 - **Height of Working Space:** The working space **shall** be clear and extend from the grade, floor, or platform to a height of 2.0 m (6.5 ft) or the height of the equipment, whichever is greater, according to NFPA 70-2017, Article 110.26.
 - **Additional Minimum Working Space:** Additional minimum working space may be required for voltages greater than 1000V and/or specific equipment installation conditions. See NFPA 70-2017, Article 110.26 and the Authority Having Jurisdiction (AHJ) for additional information.
 - See “Spacing Requirements for Electrical Power Equipment (AC or DC)” on page 9-6 for more information.
- All internal wiring **shall** be copper (see NFPA 70-2017, Article 110.5, for additional information).
- Wire, terminals and lugs **shall** be of similar or compatible metals (NFPA 70-2017, Article 110.14).



NOTE

The required Working Space about an electrical panel **shall** not be used for storage. See NFPA 70-2017, Article 110.26(B).

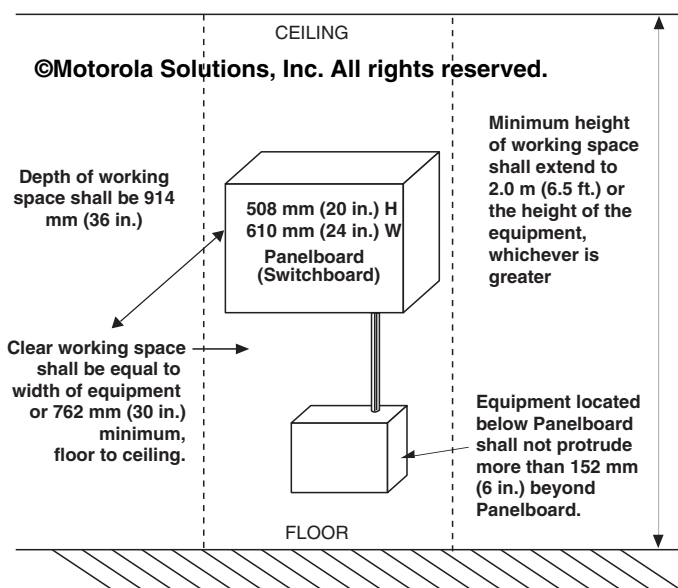

Figure 6-4 Electrical Panel Clearances

6.2.6 Power Panels

The following requirements **shall** be observed when specifying and installing interior electrical service:

- See “Interior Electric” on page 6-8 for panel working space (clearance) requirements.
- Each main distribution panel **shall** have its own main overcurrent protective device (circuit breaker/fuse). See NFPA 70-2017, Article 408.36(B), for additional information.
- All interior panelboards and junction boxes **shall** be NEMA Type 1 general purpose for indoor application.
- All panelboards supplied by a feeder(s) **shall** be permanently marked to indicate where the power originates. The label **shall** be permanently affixed, of sufficient durability to withstand the environment involved, and not handwritten. See NFPA 70-2017, Article 408.4(B).
- More than one distribution panel may be necessary for large single equipment rooms in order to support the number of required branch circuits. If more than one distribution panel is utilized then all panels should be fed from the same separately derived system. This is done to prevent ground loops from multiple neutral ground bonds at the transformer. See IEEE 1100-2005 for additional information.
- Power panelboards **shall** be bonded to the interior single point bonding and grounding system. See “Internal Bonding and Grounding (Earthing)” on page 5-1 for the requirements on the proper methods of bonding and grounding equipment.
- Where using a UPS, two distinct power panels **shall** be utilized as follows:
 - Equipment Power Panel (UPS Panelboard)
This panel provides power for the communications/electronics equipment and all associated electrically powered items. It is fed from the UPS.
 - Utility Power Panel
This panel provides power for circuits and loads other than communications and electronics. This panel feeds the UPS and non-UPS electrical equipment at the site, such as lighting, HVAC and wall mounted receptacles.

6.2.6.1 Outdoor Electrical (Branch Circuits)

This section provides requirements for branch circuits that exit the equipment shelter for use with outdoor equipment.

- All outdoor electrical equipment **shall** be protected from the environment and sealed from the elements.
- All outdoor receptacles **shall** be Ground-Fault Circuit-Interrupter (GFCI) type receptacles or supplied from GFCI breakers. See NFPA 70-2017, Article 210.8, for additional information.
- Non-flexible conduit **shall** be used for all exterior circuit branches. Exceptions are feeds to vibrating equipment such as air conditioning units, which may use liquid-tight flexible sealed conduit.
- All exterior wall penetrations through which conduit passes **shall** be sealed.
- Exterior panelboards, receptacles and switches **shall** be housed in NEMA Type 3 or Type 3R housing.



WARNING

To prevent electric shock or electrocution, GFCI receptacles shall be used when working with equipment outdoors. The GFCI receptacle shall be tested for proper operation using the manufacturer supplied Test Button.

6.2.7 Circuit Protection



NOTE

Locked-rotor starting current **shall** be considered when specifying breaker values for such items as the air conditioner compressor motors and fans. Power amplifiers keyed to full power can also pose unusual start-up loads. Such loads may also affect the type of breaker used for the circuit.

The following requirements **shall** be observed when specifying and installing circuit protection devices:

- A means of removing power from a given circuit or load without disrupting other equipment **shall** be provided.
- Branch circuits for communication equipment **shall** be 15 A minimum. 20 A circuits are recommended for each branch circuit feeding communications equipment and associated equipment. The outputs of a Power Distribution Unit (PDU) **shall not** be required to be 15 A minimum; the circuits may be sized according to load requirements and the listing of the PDU. See “Power Distribution Units (PDU)” on page 6-12 for more information.
- Branch circuit breakers for all other equipment such as lighting, heating and air conditioning **shall** be rated per manufacturer specifications and as per code.
- Breakers and their associated receptacles **shall** be uniquely labeled and correlated to the respective power panel unless required differently for specific equipment. See NFPA 70-2017, Article 408.4, for additional information. See Figure 6-5 and Figure 6-6.
- Panel schedule **shall** be filled out and kept up to date. See NFPA 70-2017, Article 408.4, and Figure 6-5 for additional information.
- Circuit breakers **shall** be sized to protect the conductor attached to them, not the load on the circuit. See NFPA 70-2017, Article 240.4, for additional information.



Figure 6-5 Panel Schedule



Figure 6-6 Receptacle Circuit Identification

6.2.8 Conductors

The following requirements **shall** be observed when specifying and installing conductors:

- Copper conductors **shall** be used.
- Aluminum conductors **shall not** be used.

- All branch conductors **shall** have an allowable current carrying capacity (referred to as “ampacity”) equal to or greater than the non-continuous load plus 125% of the continuous load. See NFPA 70-2017, Article 210.19(A)(1), for additional information.
- It is recommended that a conductor of 8 mm² csa (#12 AWG) minimum be used in the equipment panel for circuit branches.

**NOTE**

On three-phase branch circuits it is very important that the neutral conductor be sized appropriately for overcurrent that may be induced upon the neutral by a possible load imbalance.

- On three-phase branch circuits the neutral conductor **shall** be equivalent in size to its associated load carrying conductors. In special circumstances (such as highly reactive loads that may generate harmonics), the neutral should be increased to up to 175% of its original size. See NFPA 70-2017, Article 220.61, for additional information.
- All single phase circuits **shall** be 3-wire (phase, neutral and ground). Metallic conduits **shall not** be relied on as the equipment grounding conductor for sensitive electronic equipment (IEEE 1100-2005).

6.2.9 Conduit

The following requirements **shall** be observed when specifying and installing conduit:

- All interior surface-mounted building wiring **shall** be run in rigid Electrical Metallic Tubing (EMT) or electrical raceways. See NFPA 70-2017, Article 358, and IEEE 1100-2005, paragraph 8.4.8.2. for additional information.
- The conduit **shall not** be used as the Equipment Grounding Conductor (EGC). An individual circuit equipment grounding conductor **shall** be installed in each conduit exiting the panelboard and be connected electrically. The arrangement of grounding connections **shall** be such that the disconnection or removal of a receptacle, fixture or other device fed from the box will not interfere with (or interrupt) the equipment grounding conductor continuity.
- The conduit **shall** be securely fastened every 3 m (10 ft) and within 914 mm (3 ft) of any receptacle box, junction box, panelboard or any termination of the conduit. See NFPA 70-2017, Article 358.30, for additional information.
- For tenant improvements, applicable local codes **shall** be observed.
- Conduit runs may be mounted to the cable tray support structure, not the cable tray. These cable trays (along with ceiling attachments) **shall** be designed and installed to support an EMT distribution system, including all hardware-related fittings and boxes, as well as the distributed load in the tray. See NFPA 70-2017, Article 314.23, for additional information.
- Flexible metal conduit may be used to carry a circuit branch conductor to vibrating equipment and suspended lighting fixtures. See NFPA 70-2017, Article 348, for additional information.
- Liquid-tight flexible metal conduit **shall** be used where additional protection from liquids, vapors or solids is required. See NFPA 70-2017, Article 350, for additional information.

6.2.10 Hardwiring of Equipment and Dedicated Receptacles

Extension cords **shall not** be used to power permanent communication equipment at a site.

Where an open equipment rack is used, hardwiring of power is not always practicable. Mounting a dedicated simplex receptacle or receptacle assembly on the rack may be the most convenient method of supplying power, especially if multiple pieces of equipment are mounted on the rack. This is also a convenient way to install personal protection Type 3 SPD devices to the equipment.

These receptacle assemblies can be manufactured in advance and mounted to the top face of an equipment rack. Mounting can also use a fabricated power pole mounted between racks. See “Power Distribution Units (PDU)” on page 6-12 for more information.

6.2.11 Power Distribution Units (PDU)

A Power Distribution Unit (PDU) is a rack mounted distribution product with one or more input power sources and multiple outputs. The PDU outputs are thermally protected and designed to distribute either AC or DC power at or near the equipment rack.

PDUs vary from simple rack-mounted power strips to larger floor-mounted units with multiple functions, including power filtering to improve power quality, intelligent load balancing, and remote monitoring and control by LAN or SNMP. This kind of PDU placement offers capabilities such as power metering at the inlet, outlet and PDU branch circuit level.

Requirements for PDUs are:

- PDUs **shall** be listed to UL 60950-1 or equivalent (for example, CSA or TUV).
- PDUs **shall** be installed per the manufacturer's requirements.
- PDU outputs **shall** be overcurrent protected for the receptacle type provided (for example, AC/DC).
 - Overcurrent protection **shall not** exceed the receptacle rating.
 - Overcurrent protection may be sized less than the receptacle rating and according to the actual load requirement for a given circuit.

Figure 6-7 shows an example of a PDU with multiple inputs and outputs.



Figure 6-7 Example of Power Distribution Unit with Multiple Inputs and Outputs

Figure 6-8 shows an example of a PDU with a single main input (L1, L2, neutral and ground) and multiple outputs.



©Motorola Solutions, Inc. All rights reserved.

Figure 6-8 Example of Power Distribution Unit with Single Main Inputs and Multiple Outputs



IMPORTANT

Power Distribution Units shall include an internal ground (earth) connection point (for example, a threaded hole or post) for bonding to the AC power Equipment Grounding Conductor (EGC), in addition to any external connection designed for bonding to the internal bonding and grounding system.

6.2.12 Receptacles

The following requirements **shall** be observed when specifying and installing receptacles for powering communications equipment:

- To ensure system reliability and availability, each major piece of equipment **shall** have its own dedicated individual branch circuit and dedicated simplex receptacle (see IEEE 1100-2005).
- To ensure system reliability and availability, redundant power supplies for the same piece of equipment **shall** be supplied from different branch circuits.
- Redundant equipment pairs **shall** be supplied from different branch circuits.
- Adequate service receptacles **shall** be provided for the service technician and associated test equipment. These receptacles **shall** be conveniently located near the equipment to be serviced (typically at least one per row of equipment). These receptacles **shall** be on separate circuits from the mission critical communications equipment.
- Equipment racks may require special attention to support the dedicated simplex receptacle scheme. To comply with the dedicated simplex receptacle concept, receptacles must be located on or very near the rack of equipment. One method is to use a specialized Multi-Receptacle AC panel with dedicated circuits that **shall** be mounted on the equipment rack or enclosure. These Multi-Receptacle AC panels **shall** be hard wired to the breaker panel, and each simplex receptacle **shall** use an individual branch circuit. See “Power Distribution Units (PDU)” on page 6-12.
- To eliminate the possibility of two pieces of equipment turning on at the same time and momentarily exceeding the amperage capacity of the circuit, simplex receptacles should be used instead of duplex receptacles.



NOTE

Duplex receptacles may be fed from two separate circuits only if the connecting tabs on the receptacles are removed. The neutral **shall not** be shared by two receptacles. In this case, only one equipment grounding conductor is required for the two circuits. **If the tab is removed**, NFPA 70-2017, Article 210.4(B), states: “Each multiwire branch circuit **shall** be provided with a means that will simultaneously disconnect all ungrounded conductors at the point where the branch circuit originates.”



IMPORTANT

Motorola Solutions does not recommend the multiwire branch circuit for critical equipment.

- Receptacle ratings should be determined by conductor and circuit breaker current ratings. Consider future expansions.
- Isolated ground receptacles **shall not** be used unless recommended by the equipment manufacturer (IEEE 1100-2005). Isolated ground receptacles are not recommended for use at operator positions. See “Bonding to Power at the Operator-Type Equipment Position” on page 5-138.
- All 120 VAC receptacles **shall** have three conductors: phase, neutral and ground (IEEE 1100-2005).
- Power cord plugs **shall** be supported with strain reliefs adequate to prevent accidental disconnection where applicable. Twist-lock plugs **shall not** be used in lieu of strain relief.
- All communications equipment receptacles **shall** have the electrical box or cover plate permanently marked with the service panel and appropriate circuit identification. This identification **shall** be readily visible without requiring removal of the plug.
- Receptacles meant to serve loads other than communication equipment **shall** be fed from the main distribution panelboard, **not** from the equipment panel or the UPS. See “Power Quality” on page 6-18 for additional information.
- Outlet boxes or enclosures **shall** be securely mounted (NFPA 70-2017, Article 300.11 and 314.23). Cable ties **shall not** be used as a method of securing outlet boxes or receptacles.

6.2.12.1 Receptacle Testing

As part of the system commissioning process, all receptacles powering electronic equipment **shall** be tested using a commercially available receptacle tester. The receptacle tester **shall** test according to UL 1436 (or equivalent).



IMPORTANT

The receptacle testing procedures documented in this section should be performed prior to power quality measurements. See “Power Quality” on page 6-18 for additional information.



NOTE

The tester used **shall** be designed for testing receptacles serving electronic equipment (see Figure 6-9 for an example). The tester **shall** test according to UL 1436 (or equivalent).

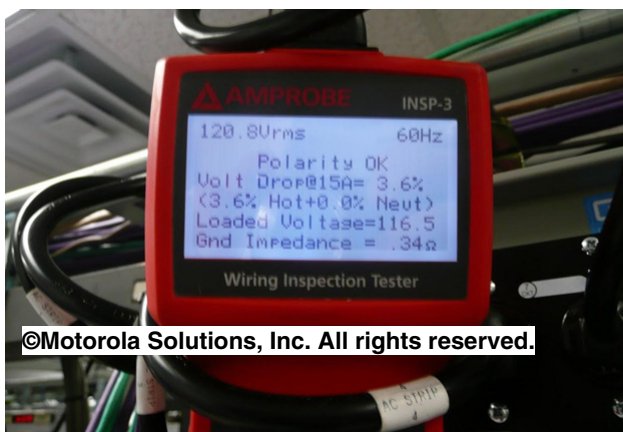

Figure 6-9 Example of Receptacle Tester

The Receptacle Tester **shall** test the following:

- Voltage
- Open ground
- Open neutral
- Open hot
- Hot/ground reversed
- Hot/neutral reversed
- Circuit voltage drop percentage (under load)
- Equipment Grounding Conductor (EGC) integrity and impedance
- Ground Fault Circuit Interrupter (GFCI) functionality (where applicable)



WARNING

Follow all safety Warnings and Cautions from tester manufacturers.



NOTE

Follow instructions from tester manufactures for performing each test.

Table 6-1 indicates the expected results for receptacle testing.

Table 6-1 EXPECTED RESULTS FOR RECEPTACLE TESTS

Test	Expected Result	Notes
Voltage	Measured Circuit Voltage	Should be within the specific equipment tolerances. If the equipment tolerance limits are unknown, a high threshold of 126 V, and a low threshold of 108 V, is recommended for monitoring 120 V circuits (IEEE 1100-2005, section 6.4.2.4). See “Power Quality” on page 6-18 for more information.
Open Ground	Pass/Fail	None
Open Neutral	Pass/Fail	
Open Hot	Pass/Fail	
Hot/Ground Reversed	Pass/Fail	
Hot/Neutral Reversed	Pass/Fail	
Circuit Voltage Drop Percentage (Under Load)	Percentage of Voltage Dropped (%)	Per NFPA 70-2017, Article 210.19(A) Informational Note 4 recommendations, the maximum voltage drop measured at a receptacle should not exceed 5% of the source voltage. See tester instructions for testing details.
EGC Integrity and Impedance	Ohms (Ω) Pass/Fail	See Table 6-2 for IEEE recommended maximum impedance values.
GFCI Functionality	Pass/Fail	None

**IMPORTANT**

Failure of any test shall be investigated and corrected by a qualified electrical contractor.

Table 6-2 indicates the IEEE recommended maximum Equipment Grounding Conductor (EGC) impedance, based on the circuit overcurrent device rating (see IEEE 1000-2005, Table 6-1).

Table 6-2 IMPEDANCE GUIDELINES FOR EFFECTIVE GROUNDING OF SYSTEMS AND EQUIPMENT RATED 600 V OR LESS

Overcurrent Device Rating (A)	Circuit Voltage to Ground	
	120 V	277 V
10 A	1.6 Ω	-
15 A	1.0 Ω	1.0 Ω
20 A	0.8 Ω	0.7 Ω
25 A	0.6 Ω	0.6 Ω
30 A	0.5 Ω	0.5 Ω
40 A	0.4 Ω	0.3 Ω
60 A	0.1 Ω	0.1 Ω

Table 6-3 provides an alternate maximum EGC impedance calculation based on actual conductor gauge and length. Values indicated in the table are based on the use of copper conductors (see NFPA 70-2017, Table 8).

**NOTE**

Table 6-3 can also be used for hot or neutral conductor impedance calculations.

Table 6-3 MAXIMUM EGC IMPEDANCE PER 100 FEET (COPPER CONDUCTORS)

Conductor Size		Conductor Type	Conductor Impedance	
American Wire Gauge (AWG)	Cross Sectional Area (mm ²)		Ohms (Ω) per 100 ft	Ohms (Ω) per km
14 AWG	2.08 mm ²	Solid	0.319 Ω	10.4 Ω
		Stranded	0.326 Ω	10.7 Ω
12 AWG	3.31 mm ²	Solid	0.201 Ω	6.57 Ω
		Stranded	0.025 Ω	6.73 Ω
10 AWG	5.26 mm ²	Solid	0.126 Ω	4.148 Ω
		Stranded	0.129 Ω	4.226 Ω

Table 6-3 MAXIMUM EGC IMPEDANCE PER 100 FEET (COPPER CONDUCTORS) (CONTINUED)

Conductor Size		Conductor Type	Conductor Impedance	
American Wire Gauge (AWG)	Cross Sectional Area (mm ²)		Ohms (Ω) per 100 ft	Ohms (Ω) per km
8 AWG	8.37 mm ²	Solid	0.0786 Ω	2.579 Ω
		Stranded	0.0809 Ω	2.653 Ω
6 AWG	13.30 mm ²	Stranded	0.0510 Ω	1.671 Ω
4 AWG	21.15 mm ²	Stranded	0.0321 Ω	1.053 Ω
3 AWG	26.67 mm ²	Stranded	0.0245 Ω	0.833 Ω
2 AWG	33.62 mm ²	Stranded	0.0201 Ω	0.661 Ω
1 AWG	42.41 mm ²	Stranded	0.0160 Ω	0.524 Ω

6.2.13 Receptacle Strips

- Extension blocks or receptacle strips **shall not** be mounted on the floor. Damage can result from foot traffic or water, and water seepage or fire sprinkler activation may pose an electrocution hazard to personnel.
- Receptacle strips are intended to provide AC power to low-power equipment where several line-powered items are closely collocated (such as an operator position). In general, the following considerations need to be observed in selecting and installing receptacle strips:
 - Receptacle strips **shall** be listed by a Nationally Recognized Testing Laboratory (NRTL), such as UL.
 - Receptacle strips **shall** be of metal construction.
 - If powering multiple similar devices from a receptacle strip, ensure that failure of the strip does not affect system availability. For example, do not plug all modems into the same receptacle strip.
 - Receptacle strips are limited to specific applications only where a receptacle strip is suitable for use.
 - Receptacle strips **shall** be easily mountable without requiring disassembly.
 - AC power receptacle strips **shall** have a 3-prong power cord.
 - Receptacle strip **shall** be securely mounted to the supporting structure using intended bolt mounting and **shall not** be secured by being tie-wrapped.
 - Receptacle strips **shall not** include ON/OFF switches unless the ON/OFF switch is covered to help prevent the switches from being inadvertently switched off.
 - Consumer-grade surge-protected or locally fused receptacle strips **shall not** be used. Proper equipment setup and facility electrical design should accommodate these requirements.
 - No more than one receptacle strip **shall** be connected to the same branch circuit.
 - Redundant equipment pairs **shall not** be connected to the same receptacle strip.
 - Items considered individually critical (where no backup can easily be implemented) **shall not** be powered from a receptacle strip.
 - If multiple receptacle strips are used, they **shall** be plugged into dedicated simplex receptacles on individual branch circuits.

6.3 Power Quality

Power quality is defined as “the concept of powering and grounding electronic equipment in a manner that is suitable to the operation of that equipment and compatible with the premise wiring system and other connected equipment” (IEEE 1100-2005 and IEEE 1159-2009). In order to operate reliably, electronic equipment **shall** be supplied with quality AC power.

One of the objectives of Motorola Solutions site standards and guidelines is to establish benchmarks for designing optimum equipment operating environments. Providing quality power to electronic equipment is a key to system availability and system reliability.

See “Glossary” on page 1-13 for definitions of terms relating to power quality.



IMPORTANT

The receptacle testing procedures documented in this chapter should be performed prior to measurement of power quality. See “Receptacle Testing” on page 6-14 for additional information.

6.3.1 Fundamentals of Power Quality

This paragraph presents a brief introduction to power quality. See IEEE 519, IEEE 1100 and IEEE 1159 for additional information. The requirements and recommendations presented in this paragraph take into consideration established industry codes and standards for achieving operational environments that are suitable for electronic equipment. The American National Standards Institute (ANSI), British Standards Institution (BSI), Institute of Electrical and Electronics Engineers (IEEE), International Electrotechnical Commission (IEC) and the Telecommunications Industry Association (TIA) have developed steps necessary for establishing a foundation to support the operation of electronic equipment.

The quality of power supplied to electronic equipment is influenced by, but not limited to, the following:

- Equipment load requirements
- Grounding (earthing) of the facility
- Sufficient delivery of power
- Interaction between connected loads
- Internal and external wiring
- Placement of the electronic equipment within the facilities

Many of the areas of concern affecting power quality are also addressed as minimum safety requirements specified by NFPA 70-2017 or other electrical codes in effect by the Authority Having Jurisdiction (AHJ). However, these minimum safety requirements are typically not sufficient to support the operation of electronic equipment.

6.3.2 Common Causes of Power Quality Problems

Table 6-4 summarizes some of the common causes of power quality problems. See IEEE 1159-2009, section 4.4, for additional information.

Table 6-4 COMMON CAUSES OF POWER QUALITY PROBLEMS

Problem	Common Cause
Frequency Deviation	<ul style="list-style-type: none"> • Faults on the bulk power transmission system • Large block of load being disconnected • Large source of generation going off-line • Generator system faults

Table 6-4 COMMON CAUSES OF POWER QUALITY PROBLEMS (CONTINUED)

Problem	Common Cause
Voltage Sags (or dips) See Figure 6-11 for example.	<ul style="list-style-type: none"> • System faults • Switching of heavy loads • Starting of large motors • Large load changes • Adverse weather conditions
Voltage Swells See Figure 6-11 for example.	<ul style="list-style-type: none"> • System faults (for example, an open neutral conductor) • Single line-to-ground fault on the system resulting in a temporary voltage rise on the non-faulted phases • Switching off a large load • Switching on a large capacitor bank
Transients See Figure 6-12 for example.	<ul style="list-style-type: none"> • Adverse weather conditions • Lightning • Load switching • Fault clearing • Capacitor discharge • Utility switching
Total Harmonic Distortion (> 5%) See Figure 6-13 for example.	<ul style="list-style-type: none"> • Normal operation of nonlinear devices (for example, switched-mode power supplies often found in computers) • Noise generating loads • Synthesized sine wave from a UPS or power conditioner • Overloaded building or utility transformer
Noise See Figure 6-14 for example.	<ul style="list-style-type: none"> • Power electronic devices • Control circuits • Arcing equipment • Loads with solid-state rectifiers • Switching power supplies • Improper grounding can exacerbate noise problem

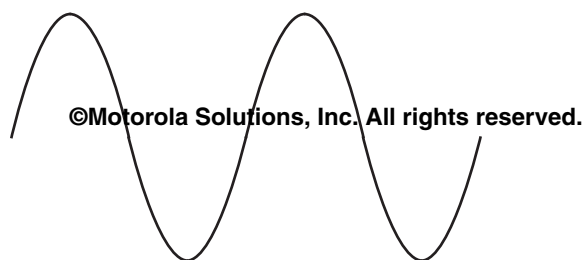
**Figure 6-10** Normal Sinusoidal Waveform

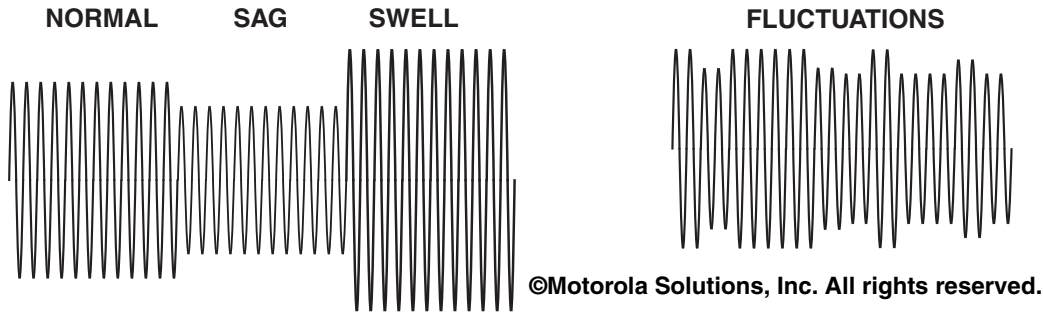

Figure 6-11 Voltage Sags, Swells and Fluctuations

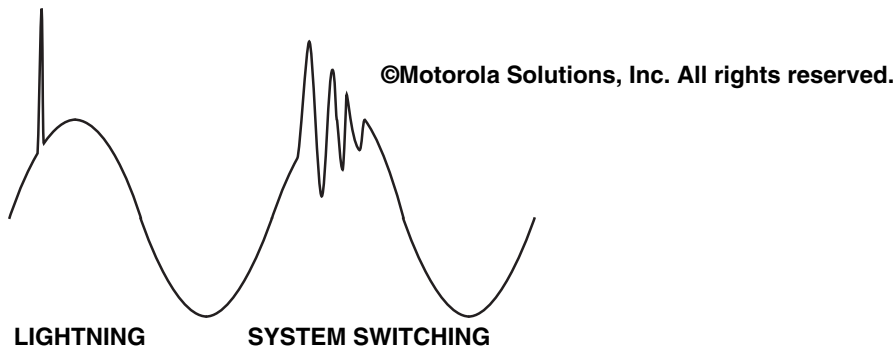

Figure 6-12 Example of Transient Voltages

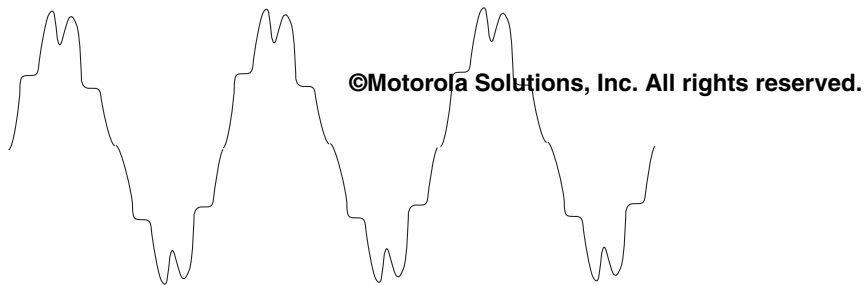

Figure 6-13 Example of Harmonic Distortion



Figure 6-14 Example of Noise

6.3.3 Common Effects of Power Quality Problems

Table 6-5 summarizes the common effects of power quality problems on connected equipment (see IEEE 1159-2009, section 5.5 for additional information).

Table 6-5 COMMON EFFECTS OF POWER QUALITY PROBLEMS

Problem	Common Effect
Frequency Deviation	<ul style="list-style-type: none"> • Writing errors in any electronic writing device • Incorrect clock timing
Voltage Sags (or dips)	<ul style="list-style-type: none"> • Equipment shutdown • Power supply interruptions • CPU lock up • Data errors
Voltage Swells	<ul style="list-style-type: none"> • Microprocessor failure • Equipment failure • Progressive damage to power supplies
Transients	<ul style="list-style-type: none"> • Damage to microprocessors • Data errors or loss • Lock ups • Catastrophic failure of electronic equipment
Total Harmonic Distortion (> 5%)	<ul style="list-style-type: none"> • Failure of microprocessor controlled equipment • Overheating of electrical system components • Decreased life expectancy of electrical system transformers • Circuit breakers tripping

6.3.4 Common Power Quality Problem Remedies

Table 6-6 generalizes some common remedies of power quality problems. A power quality engineer may be required to help resolve power quality problems.

Table 6-6 COMMON REMEDIES FOR POWER QUALITY PROBLEMS

Problem	Common Remedy
Frequency Deviation Frequency variations are much more likely to occur when equipment is powered by an onsite generator, versus the AC utility (IEEE 1159-2009, section 4.4.7).	<ul style="list-style-type: none"> • Report problem to the utility if the frequency deviation is measured on the AC utility • Make corrective repairs to onsite generator if the frequency deviation is measured on the generator
Voltage Sags (or dips)	<ul style="list-style-type: none"> • Corrective wiring • Relocation of critical loads • Power conditioners • UPS systems
Voltage Swells	<ul style="list-style-type: none"> • Relocation of critical loads • Power conditioners • UPS systems

Table 6-6 COMMON REMEDIES FOR POWER QUALITY PROBLEMS (CONTINUED)

Problem	Common Remedy
Transients	<ul style="list-style-type: none"> • Surge Protective Devices • Filters
Total Harmonic Distortion (> 5%) See IEEE 519, <i>Recommended Practices and Requirements for Harmonic Control in Electric Power Systems</i> , for additional information.	<ul style="list-style-type: none"> • Isolating the noise • Power conditioners • Moving loads away from noise generators • UPS with a true sinusoidal waveform output (typically found with IGBT (insulated gate bipolar transistor) rectifier technology)
Excessive Neutral-to-ground Noise at the Receptacle (approximately 2-3 V peak)	<ul style="list-style-type: none"> • If the neutral-to-ground bond is located remotely from the shelter, install an isolation transformer at the AC power feed into the building. This would establish a new neutral-to-ground bond, resulting in a decrease in noise. • UPS with an isolation transformer • Power conditioner

6.3.5 Power Quality Testing Thresholds

Table 6-7 lists the recommended thresholds when testing AC power quality in most single-phase and three-phase configurations (IEEE 1100-2005, Table 6-2, and IEEE 1159-2009, Table 5). The actual thresholds used should be based on the installation requirements of the connected equipment, as the connected equipment may have more stringent requirements.

Table 6-7 SUGGESTED THRESHOLD SETTINGS FOR 120 V LOADS

Category	Value	Notes
Conducted Phase Voltage Thresholds		
Voltage Sags	108 V rms	-10% of nominal supply voltage
Voltage Swells	132 V rms	+10% of nominal supply voltage
Transients	200 V peak	Approximately twice the nominal phase-neutral voltage
Noise	1.5 V	Approximately 1% of the phase-neutral voltage
Total Voltage Harmonic Distortion	5%	The voltage distortion level at which loads may be affected
Frequency Deviation	± 0.5 Hz	
Conducted Neutral-to-Ground Voltage Thresholds		
Voltage Swells	3.0 V rms	Typical level of interest for neutral and/or ground problems
Impulsive Transient	20 V peak	10% to 20% of phase-neutral voltage
High Frequency Noise	2-3 V peak	Typical equipment susceptibility level

6.3.6 Steps to Developing a Power Quality Plan

Prior to deployment of electronic equipment, a power quality action plan should be established. To help determine necessary corrective action, the equipment's operating norms should be reviewed according to the manufacturers' stated requirements for optimal performance. Next, a complete assessment of the facility's current electrical environment should be conducted and compared to the requirements for the equipment. Load requirements, grounding, bonding, isolation and protection requirements should be considered.

To help maintain an optimal electrical environment, a power quality monitoring plan should be in place. The power quality monitoring plan should require regular review of the performance of the site's operating norms. This should include regular monitoring and recording of the site's power system, its connected loads, failures and interruptions. The objective of the power quality monitoring program is to identify problems and take corrective actions before incidental interference results in a wide area failure.

6.3.7 General Recommendations to Help Promote Good Power Quality

The following list presents some general recommendations to help promote good power quality. See IEEE 1100-2005, *Recommended Practice for Powering and Grounding Electronic Equipment*.

- Use a UPS or other source of backup power on critical loads.
- Use a UPS system that provides a true sinusoidal wave output to help maintain a total harmonic distortion (THD) below 5% (typically found in a UPS that uses IGBT rectifier technology).
- Isolate critical loads and electronic equipment from noisy or inductive loads (for example, motor-driven cleaning equipment, space heaters, fans, copiers and printers).
- Separate critical loads/electronic equipment and other loads onto different panelboards (IEEE 1100-2005).
- Install an insulated grounding conductor on receptacles that feed critical loads or electronic equipment, versus relying on the metallic conduit (IEEE 1100-2005, section 8.5.3).
- Match circuit availability to the load requirements (for example, 15 amp circuits are not powering equipment that requires a 20 amp circuit).
- Maintain minimum separation between AC power conductors and other communications cabling.
- Restrict access to power control panels and mark electrical receptacles according to use (for example, HVAC controls, electrical panels and switch boards, circuits for critical loads or other uses).
- Follow the recommendations/requirements of Chapter 7, "Surge Protective Devices."
- Follow the recommendations/requirements of Chapter 6, "Power Sources."
- Follow the recommendations/requirements of Chapter 5, "Internal Bonding and Grounding (Earthing)."
- Follow the recommendations/requirements of Chapter 4, "External Grounding (Earthing) and Bonding."
- Follow the recommendations/requirements of Appendix C, "Protecting Against Electrostatic Discharge in Equipment Rooms and Dispatch Centers".

6.3.8 Power Quality Testing Locations

When monitoring a site that is serving several loads, it may be advantageous to initially install the power quality monitor at the power panel feeding the system to obtain an overall profile of the voltage. The power quality monitor can then be relocated to the circuits serving individual loads or loads that are experiencing malfunctions and failures. Comparison of disturbance data can help locate the source of the disturbances and determine how to most effectively remedy the problem. See IEEE 1100-2005, section 6.4.2.5.



Figure 6-15 Example of Power Quality Testing Equipment and Location



NOTE

A power quality engineering firm may be required to assist with power quality testing and/or troubleshooting.

Motorola Solutions recommends the following locations for testing power quality on 120 V loads (phase-to-neutral loads):

- To assess the power quality delivered to an individual piece of electronic equipment, test at the equipment's receptacle, especially if the equipment is exhibiting malfunctions and/or failures.
- To assess the quality of output power from a power conditioner or UPS system, test at the power conditioner or UPS power panelboard (or as close as practicable).
- To assess the power quality of secondary distribution, test on the secondary of the equipment room transformer.
- To assess the overall power quality delivered to a facility, test at the facility's main electrical panel.



WARNING

Only qualified personnel shall open an electrical panel to attempt a power quality measurement. Lethal voltages may be present.

6.3.9 Power Quality Testing Duration

The monitoring period is a direct function of the monitoring objective. Usually the monitoring period attempts to capture a complete power period, an interval in which the power usage pattern begins to repeat itself. For example, an industrial plant may repeat its power usage pattern each day or each shift. Depending on the monitoring objective, it may be necessary to monitor as little as one shift. See IEEE 1159-2009, section 7.4.7.1.

It is generally recommended that the minimum monitoring period include at least one full work cycle, normally seven or eight days. Longer monitoring periods are often needed to record disturbances that occur on a random or seasonal basis. See IEEE 1100-2005, section 6.4.2.5, for additional information.

6.4 Rectifier/DC Power Systems

This section provides guidelines and specifies requirements for selecting and installing site rectifier/DC power systems and components. Note that although specific recommendations are stated here, actual equipment specifications are largely determined by factors peculiar to the installation being performed. These stipulations are noted throughout the section.

6.4.1 Rectifier System Requirements

6.4.1.1 Acceptable Rectifier Types

Two general types of rectifiers are acceptable for powering communications equipment. The types are:

- **Controlled Ferroresonant Rectifier**

- A controlled ferroresonant rectifier exhibits an exceptionally good Mean Time Between Failure (MTBF) and typically provides an output exceeding 110% - 120% of its rating for the life of the rectifier. Forced load sharing is an essential feature of these rectifiers. In a multiple rectifier system, it prevents a single rectifier's output from drifting down and becoming inefficient.
- Both a potential drawback as well as benefit of this rectifier is its transformer. In an area prone to excessive AC transients, a controlled ferroresonant rectifier will continue to function satisfactorily. However, the transformer is large and heavy. Suitability of this rectifier type will be based on balancing these criteria.
- Although a ferroresonant supply is simple and low cost and handles high current, it cannot handle AC line frequency shifts, particularly on the low side. An applied low line frequency (even 59 Hz) causes the ferroresonant supply to draw high current over excessive ON cycles. This overheats the transformer and causes close to short-circuit conditions within the tuned reactive circuit. A backup generator with a defective speed governor is a typical source of this trouble.

- **Switchmode Rectifier**

- A switchmode rectifier offers a size and weight advantage over ferroresonant rectifiers in that its transformer is smaller and lighter than controlled ferroresonant rectifiers. This type of rectifier will provides an output of 105% of its rating for the life of the rectifier.
- The drawback to the switchmode rectifier is that it does not have the large transformer to absorb transient surge voltages. These transient surges can shorten the life of the switchmode rectifier. In areas prone to significant transient voltages, controlled ferroresonant rectifiers may be a better choice. The lower MTBF of a switchmode rectifier can be offset by its ease of replacement. Also, the inefficiency at low output levels of these rectifiers is not nearly as severe as that of the controlled ferroresonant rectifier; therefore, forced load sharing is not required. A switch mode rectifier that is well-filtered to prevent radiated RFI and superimposed noise on the DC output circuit should be selected.

Silicon Controlled Rectifier (SCR)-based rectifier systems are not acceptable for powering Motorola Solutions systems, due to tendencies of SCRs to allow AC transients to propagate to the DC side.

6.4.1.2 Redundancy

An n+1 redundancy setup is recommended, at a minimum, for the rectifier system. An n+1 redundant scheme employs one rectifier more than is required to power the system. In many cases, the redundant rectifier also provides for recharging of the batteries after a power outage.

6.4.1.3 Rectifier Sizing

In general, the power system selected should be appropriately sized based on the installation being performed.

- In systems requiring 1200 A or less, 2.5 kW (50A@-48V; 100A@24V) switchmode modular rectifiers (or equivalent) are recommended.

- In systems requiring more than 1200 A, modular rectifiers as described above are not typically recommended. This is based on the following:
 - An n+1 redundancy using low capacity rectifiers may not provide sufficient reserve capacity to fully recharge discharged batteries within 24 hours. An n+2 or n+3 design may be necessary to handle recharge. However, this will affect overall system cost.
 - Higher-output systems based on higher-current rectifiers have a theoretically higher MTBF. A -48 V, 1000 A non-redundant system using 50 A rectifiers will contain 20 modular switchmode 100 A rectifiers. The same system using 200 A controlled ferroresonant rectifiers will contain only five 200 A rectifiers. The 200 A rectifier system has 25% as many potential points of failure as the 50 A system.

6.4.2 DC Distribution

The power board or DC power distribution center is the infrastructure around which the power system is built. A power board can be divided into two components: the meter/alarm and the control section/distribution section. The distribution section of the power system can be reconfigured, expanded and modified in many ways, however, when the meter, alarm and control section is at capacity, any further expansion requires the replacement of the power board. Over sizing of the power board is relatively inexpensive because most of the over sizing consists of copper bus bars.

6.4.3 Low Voltage Disconnect

DC systems, with battery backup, **shall** be equipped with a Low Voltage Load Disconnect (LVLD). A Low Voltage Battery Disconnect (LVBD) **shall not** be substituted for the LVLD. A battery system is considered to be fully discharged when the voltage reaches 1.75 VPC (volts per cell). In a 48 volt system (24 cells) the battery plant is fully discharged when the voltage reaches 42 volts (1.75x24). Battery damage begins to occur when the voltage drops below this point.

Continuing to operate the system beyond this point with the intent of providing service to the end user at the expense of damaging or destroying the batteries may not be practicable. Internal power supplies that provide logic and memory voltages (typically +12V, -12V and +5V) are designed to provide regulated power throughout a specific input voltage range. This range is typically within a few volts of the batteries operating range. When the input voltage drops below the specified range, the output voltage of the internal power supplies will no longer be within the specified limits. In many cases, the internal power system will shut down. If the internal power supplies do not shut down, damage or erratic operation may occur. Although a low voltage disconnect does protect the battery plant, it also is required to protect the load equipment.

6.4.4 Overcurrent Protection

Because fuses may not always be available, appropriate circuit breakers are recommended.

Overcurrent protection should be a minimum of 50% larger than the **anticipated** load for the circuit. In-rush currents (the current draw when a device is first powered on) **shall** also be considered when sizing circuit protection. Overcurrent protection **shall not** exceed the current carrying capacity (referred to as “ampacity”) rating of the conductors.

6.4.5 Power Cabling Capacity



IMPORTANT

UL-listed (or equivalent) General Use or Battery cable shall be used.

The power cables that supply DC power to site equipment **shall** be sized based on their anticipated load requirements and current carrying capacity (referred to as “ampacity”). Ampacity is determined by the short-term amperage the conductor can carry before generating sufficient heat to degrade the insulation. Ampacity is determined by the following factors:

- ambient temperature
- insulation type
- heat dissipating characteristics of the cable transport

A conductor has a higher ampacity in free air than one that is enclosed in conduit because the conduit retains heat. In certain electrical codes, a raceway is an enclosed duct that the cables are run through. As such, the ampacity rating of DC cable in a raceway is lower than that installed on the cable tray.

Independent of short-term ampacity, allowable voltage drop must also be considered when sizing power cables for DC systems. In many cases, this requires the DC power cables to be larger than the cable required for an AC system.

6.4.6 Floor and Ceiling Runs, Plenum Grade and Risers Cabling



WARNING

Power cabling SHALL not be installed within a plenum. Plenum-rated power cabling shall be used when installing power cabling within an air handling space or as otherwise permitted by NFPA 70-2017, Article 300.22 and the Authority Having Jurisdiction.



IMPORTANT

Feasibility and methods of wiring within air handling spaces and risers shall conform with jurisdictional codes.



NOTE

See “Communications Cabling Requirements for Plenums and Other Spaces Used for Environmental Air” on page 9-26 for information regarding the installation of communications cabling within plenums and other spaces used for environmental air. The same general requirements can be applied to DC power system wiring.

The following requirements specify installation practices that help, should a fire occur, minimize smoke and products of combustion from electrical wiring in areas that handle environmental air. A plenum is defined as a compartment or chamber to which one or more air ducts are connected and that forms part of the air distribution system. See NFPA 70-2017, Article 100, for additional information.

- Wiring systems of any type **shall not** be installed in ducts used to transport dust, loose stock or flammable vapors (NFPA 70-2017, Article 300.22(A)).
- Wiring systems of any type **shall not** be installed in any duct or shaft containing only such ducts, used for vapor removal (NFPA 70-2017, Article 300.22(A)).
- Wiring installed in other spaces used for environmental air, such as the area above a suspended ceiling or as otherwise defined in NFPA 70-2017, Article 300.22(C), **shall** be installed in accordance with NFPA 70-2017, Article 300.22(C).



WARNING

Electrical installations installed in hollow spaces, vertical shafts, and ventilation or air-handling ducts SHALL be installed in a manner such that the possible spread of fire or products of combustion will not be substantially increased. Openings around penetrations through fire resistance-rated walls, partitions, floors or ceilings SHALL be firestopped using approved methods to maintain the fire resistance rating. Firestopping such penetrations may be accomplished by using specially manufactured fire seals or fire-barrier caulking. See NFPA 70-2017, Article 300.21, ANSI/TIA-569-C and NECA/BICSI 568-2006 for additional information.



NOTE

Per NFPA 70-2017, Article 300.22(D), Electrical wiring in air-handling areas beneath raised floors for information technology equipment **shall** be permitted in accordance with NFPA 70-2017, Article 645.

6.4.7 DC Power Budget

To properly size DC power cables, a DC power budget **shall** be established. Figure 6-16 shows an example power budget. Typical minimum DC operating range will be from 2.33 - 1.75 VPC. This translates to 56 - 42 V for a 48 V system or 28 - 21 V for a 24 V system (some equipment will have an operating range wider than those stated in this example).

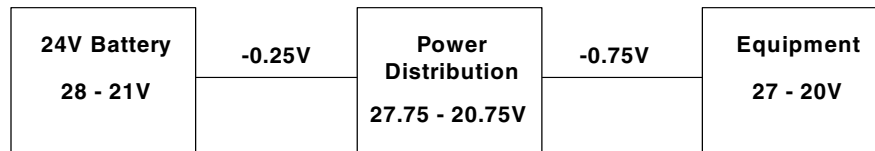

©Motorola Solutions, Inc. All rights reserved.

Battery End Voltage (21V) - losses (-0.25 - 0.75V) = 20V
Therefore, minimum equipment range must be 20 V or lower.

Figure 6-16 DC Power Budget

The first step in establishing the DC power budget is to determine the lowest voltage in the equipment operating range, called the end voltage. Where multiple pieces of equipment are connected to a given branch, the highest of the end voltages should be used for the power budget. The difference between the equipment end voltage and the battery end voltage (1.75 VPC minimum) is the allowable voltage drop. Voltage drop from the batteries to the main distribution, main distribution to remote distribution, and remote distribution to the load is then determined by load and the distances between components.

If the equipment end voltage is equal to or higher than the battery's end voltage, then a higher battery end voltage will have to be selected. Using a higher battery end voltage will increase the battery size required for the system. Normal battery end voltages range from 1.94 to 1.75 VPC. In these cases, the allowable voltage drop should be kept to the absolute minimum practicable.

6.5 Uninterruptible Power Supplies

This section provides guidelines and specifies requirements for selecting and installing a site Uninterruptible Power Supply (UPS). Note that although specific recommendations are stated here, actual equipment specifications are largely determined by factors unique to the installation being performed.

The UPS system is intended to provide short-term power to specific loads during commercial power anomalies or short-term power outages. Most UPS systems come with a standard configuration that usually provides between 5 to 10 minutes of supply voltage at full load capacity. The UPS typically provides an alarm that indicates when the UPS is nearing battery depletion.



NOTE

If the site will use a generator in addition to a UPS, the UPS **shall** be programmed or configured to allow the generator to provide power and not block the generator from connecting to its intended load. Note that generator power may be rejected by a default-configured UPS because of sensing circuitry in the UPS that rejects the generator power as not being “pure,” as compared to its normally received utility-supplied power. Any AC “line quality sampling” feature on the UPS should be disabled to prevent the UPS from rejecting the generator as a power source.



NOTE

Extended power delivery during a utility blackout is intended to be provided by a generator. The UPS is typically intended to provide transition power only between utility blackout and generator stabilization.

6.5.1 Determining UPS Output Requirements

The following requirements and considerations **shall** be observed when specifying and installing the UPS:

- UPS **shall** provide true sinusoidal output. Step-synthesized output **shall not** be acceptable.
- UPS **shall** be capable of providing full rated output power for the switchover period from utility power to stabilized generator power.
- Service panelboard **shall** have enough capacity and breaker space to accommodate the UPS.
- Intended location of UPS **shall** have adequate capability to exhaust the heat generated by the UPS.
- Ambient temperature range near UPS **shall** be in accordance with manufacturer's specification.
- Adequate spacing for safe servicing of the UPS and battery banks **shall** be considered in planning the installed location of the UPS.
- Preventive maintenance (including suggested battery replacement intervals) **shall** be in accordance with manufacturer's specifications.

6.6 Alternate Power Sources

Certain sites without access to commercial AC power utilities can use solar and/or wind-generated power. The solar panels and/or wind generator charges batteries that provide power to site equipment. Propane or liquid natural gas (LNG) generators can be used, especially in colder climates, to back up the solar/wind system.

Because solar/wind systems provide limited power, it is important when planning the power system to calculate the predicted power usage for the site. Solar power is best suited for small sites with low power requirements where the physical size and cost of the standalone power system does not become impractical. The site's transmitter duty cycles **shall** be planned so as not to exceed the maximum average current requirements.

Wind generators can be used to back up a solar panel system. If there are sunless days with wind then battery charging can still take place. Such a system could take advantage of more sun in the summer and more wind in the winter. Wind generators should be mounted higher than buildings or other obstructions where wind flow is more efficient.

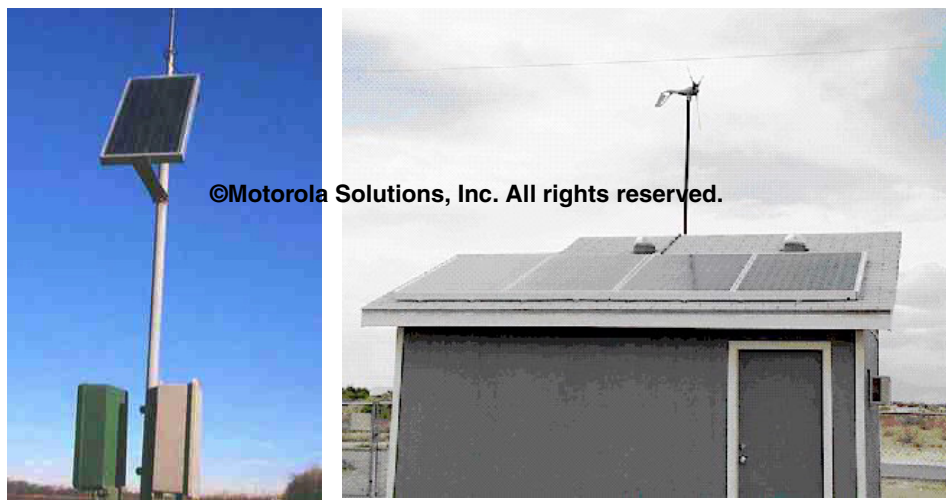

Figure 6-17 Typical Solar Panel and Wind Generator Installations

6.6.1 System Planning for Alternate Power Sources

Development of a stand-alone power system should be contracted with a firm experienced in the design of alternate power systems. To design a system capable of supplying the site's power needs, the contracted firm needs the following information:

- Total typical ampere-hours (Ah) used by all site equipment over a 24-hour period. (1 ampere used continuously for 1 hour is 1 Ah.)
- Voltage the power system must be capable of providing. Communications sites of this type typically use 12 volt or 24 volt battery systems.
- The average number of consecutive sunless days expected at the location.

The daily AH rating is calculated as shown in the following example. Given the following characteristics for a single-repeater site:

- **Single repeater requires 7A for Tx (A_{Tx}) and 1A for Rx (A_{Rx})**
- **Radio link requires 1.6A for Tx and 1A for Rx**
- **Duty Cycle (Tx/Rx) of 20%**
- Using the following formula: $[(A_{Tx} \times \%Tx) + (A_{Rx} \times \%Rx)] \times 24 \text{ hrs} = \text{average Ah required}$
- For the example characteristics given, the repeater requirement is: $[(7 \times 0.2) + (1 \times 0.8)] \times 24 = 52.8 \text{ AH/day}$
- Radio Link requirement is: $[(1.6 \times 0.2) + (1 \times 0.8)] \times 24 = 26.9 \text{ Ah/day}$
- Total requirement is: **79.7 Ah/day**

6.6.2 Requirements for Alternate Power Sources

The following requirements and considerations **shall** be observed when specifying and installing a solar power system:

- Solar panels **shall** be located away from objects that could block sunlight to the panel. Panels **shall** be pole-mounted or roof-mounted if required.
- Observe the total time a particular location has direct sunlight throughout the day. Note in any calculation or specification that the site batteries are charged only when the solar panel is exposed to the sun.
- The angle of the sunlight with respect to the solar panel throughout the year **shall** be considered. Shadows cast by nearby objects may be different when the sun's angle changes with the seasons.
- Note that the fixed panel mounting angle for year round usage in northern latitudes is typically 10 degrees more than the latitude. For example, at a latitude of 45° north the panel should be mounted at an angle of 55° from the horizontal.
- The optimum angle varies throughout the year. The amount of variation increases with latitude. Have the panel supplier recommend the mounting angle. Trackers are available that automatically move the panel to follow the sun, but these are rarely used at communications sites because of the additional maintenance and possibility of failure.
- Solar panels **shall** be at least 10% oversized to ensure that they can handle the site's power requirements.
- Battery storage **shall** be adequate to supply power to the site for 5 to 10 days without wind or sun.
- Deep-cycle batteries **shall** be used in systems experiencing up to 80% of the battery system is discharged and recharged.
- Solar panels and wind generators **shall** be mounted high enough to discourage vandalism. Bullet-resistant solar panels are available.
- Where applicable, panels **shall** be mounted high enough to clear deep winter snowfalls or ice accumulation.
- Panels **shall** be mounted and supported such that damage by high winds is avoided.
- Outside cabling **shall** be well secured and protected with conduit or run inside the mounting pole.
- Plan the battery location in accordance with "Battery Systems" on page 6-31. In earthquake-prone areas (Moment Magnitude rating 3 or greater), batteries **shall** be mounted in seismic-rated battery racks secured to the floor.

6.6.3 Installation of Alternate Power Sources

Install the solar panels and wind generator in accordance with instructions provided by the contracted design firm.

- If panels are roof-mounted, the metallic portions of the solar panel framework **shall** be bonded to the site grounding electrode system in accordance with Chapter 4, “External Grounding (Earthing) and Bonding.”
- If panels are pole-mounted, the pole ground **shall** be bonded to the site grounding electrode system in accordance with “Solar Photovoltaic Systems” on page 4-113.
- It is recommended that cabling from the outdoor portion of the system be protected in conduit and secured. Cable from pole-mounted solar panels or wind generators can be run inside the mounting pole. Appropriate precautions **shall** be taken to protect the cable from moisture ingress.
- Batteries **shall** be installed in accordance with “Battery Systems” on page 6-31 and secured against earthquakes in seismically active areas (Moment Magnitude rating 3 or greater) using a seismic-rated battery rack rated for the site's seismic zone. Secure the rack to the floor per manufacturer's instructions.

6.6.4 Maintenance of Alternate Power Sources

- Solar panels **shall** be cleaned and inspected twice a year or as required to prevent accumulation of bird droppings, dust or pollen that could reduce efficiency by blocking sunlight.
- Cracked or damaged panels **shall** be replaced.
- Manufacturers' instructions for maintaining batteries **shall** be observed.

6.7 Battery Systems

Batteries used for equipment backup can be divided into two categories: flooded cell (wet) and valve regulated (sealed). Flooded cell batteries pose greater hazards, because they emit hydrogen gas during normal operation. Sealed batteries do not typically vent hydrogen.

Where applicable, it is recommended that certified Hazardous Materials handlers be contracted to handle tasks involving the hazardous materials contained in most battery systems.

6.7.1 Battery Safety



WARNING

Motorola Solutions employees and contractors SHALL NOT handle hazardous materials unless properly trained and wearing the appropriate personal protective equipment (PPE). This includes warehouse storage, transportation and installation of battery systems.



WARNING

Wet cell battery failure involving large-scale electrolyte leakage may constitute a Hazardous Material (HAZMAT) condition. Under no circumstances SHALL regular site personnel perform HAZMAT handling. Special training and HAZMAT certification, spill mitigation and reporting and cleanup techniques/ monitoring is required under the US Federal Clean Water Act and NFPA regulations.

**WARNING**

Always use appropriate caution when working with and around batteries. Batteries used for powering equipment pose the following risks: explosion hazard resulting from inherent generation of hydrogen sulfide gas; chemical burn/blindness resulting from sulfuric acid; and very high current capabilities, with the possibility to arc, burn and start fires.

**NOTE**

Material Safety and Data Sheets (MSDS) describing the nature of HAZMAT materials present at a communications site, their reactivity, flammability and emergency spill/release mitigation and reporting are required at each site.

All applicable NFPA, OSHA and local codes **shall** be followed regarding battery installations and maintenance work.

Battery manufacturer warning statements **shall** be understood and complied with. The manufacturer's statements **shall** determine the type and extent of Personal Protective Equipment required in minimizing battery handling hazards for the batteries being installed.

This section provides safety rules to be followed when working with wet cell batteries, which require more stringent handling and safety precautions than dry cell batteries. In all cases, manufacturer's documentation **shall** be read and understood before installing or maintaining battery systems. Placards placed directly on the battery define the precautions required. See "Typical Battery Safety Kit" on page 3-29 for the required equipment to be provided at the site for working with batteries.

Observe the following general considerations regarding battery installation and maintenance:

- At all sites using wet cell batteries or gel-cell batteries where manufacturer specifies eyewash or other Personal Protective Equipment, such equipment **shall** be provided in the battery containment area.
- Because of the chemical composition, weight and bulk of many battery configurations, certified transporters and hazardous materials handlers may be required.
- Batteries may require two-person lift. Use proper lifting techniques and equipment to avoid injury.
- Installation personnel **shall** wear necessary safety equipment when installing batteries.
- "NO SMOKING" signs **shall** be prominently displayed in the battery room and on the exterior of the battery room entry door. Smoking, or the source of any spark producing materials, **shall** be strictly prohibited in this area.
- Batteries **shall** have insulated covers and/or insulated terminal protectors.
- Batteries **shall not** be used as a work surface.
- Batteries **shall** be covered when work is in progress above them.
- The US Federal Clean Water Act, with jurisdictional or local option by location, does not allow battery acid spills, which are neutralized, to be flushed down the drain or spilled on soil. Dispose of spills as required by local regulation.
- Jewelry **shall not** be worn while working on batteries.
- Insulated tools **shall** be used when working around batteries to minimize the potential for an accidental short circuit.
- A lightweight, acid resistant bib type apron in good working condition **shall** be permanently stored on site near the battery plant. The fabric **shall** be acid, caustic, puncture and flame resistant.
- An acid resistant, full face shield in good working condition, **shall** be permanently stored on site near the battery plant. The shield **shall** meet all requirements of ANSI Z87.1. Protective eye wear that does not provide full face protection is not allowed.
- One pair of acid resistant gloves in good working condition **shall** be permanently stored on site near the battery plant. These gloves **shall** be of sufficient length to cover the hand, wrist and forearm for protection from chemical splash.
- One 0.5 kg (1 lb.) box of baking soda or equivalent acid neutralizing compound **shall** be permanently stored on site near the battery plant. Water is required to mix with the baking soda.

**IMPORTANT**

Discard and replace bottled eyewash solution according to the expiration date on the bottle. Only appropriate eyewash solution shall be used.

- An OSHA approved emergency eyewash station **shall** be permanently mounted near the battery plant. The eyewash station **shall** use an isotonic saline wash capable of neutralizing acids or caustics and **shall** be able to flush the eye for 15 minutes. A plumbed eyewash station and a shower should be provided in battery areas if practicable.
- A container of non-oxidation material for coating electrical connections **shall** be left on site.
- Where applicable, provisions **shall** be made to exhaust gases produced by batteries. For wet cell batteries the manufacturer-specified stationary battery flame-arresting vent **shall** be installed on each cell. This vent **shall** be secure, clean and in good repair to help ensure maximum protection against potential explosion. Sealed batteries do not have an opening for adding electrolyte. However, there is generally a small vent hole that opens as required to vent internal gases. Two methods may be used to vent battery gases:
 - Use an exhaust fan on a timer, changing the total room air four times per hour.
 - Use a manifold system that consists of tubing connected to each cell and vented to the outside.

**NOTE**

In most cases, sealed batteries do not require venting. Check local codes for applicability. Check the labels on the batteries for the proper protection based on that particular type of battery.

- Batteries **shall** be kept clean to reduce short circuit hazards, rack corrosion and the possibility of electrical shock. Clean batteries with clear water if necessary. Do not use abrasive cleaners, detergents or petroleum-based cleaning products on battery container.
- Battery banks consisting of multiple cells with circuit protection greater than 20 amperes **shall** have 12.7 mm (0.5 in.) or greater thickness polycarbonate or hard rubber protective shield installed on a support frame and securely mounted in front of the battery rack to protect personnel should there be a violent structural failure of any cell(s). This protective shield **shall** extend from 76 mm (3 in.) above to 76 mm (3 in.) below the height of the cells being protected.
- When batteries are located in an area that is accessible to persons other than qualified system maintenance personnel, an additional protective shield as described in this section **shall** be installed to cover the top of all cells and battery circuit conductors to prevent conductive materials from contacting battery posts or circuit conductors on top of the cells.

6.7.2 Battery Containment Area

The following requirements and considerations **shall** be observed when specifying and laying out a battery containment area:

- Certain areas may require use of UL listed Intrinsically Safe vent fans, electrical and electronic equipment. See NFPA 70-2017, Article 500 through 505.
- NFPA signs advising the fire department of reactivity with water **shall** be posted (NFPA 70E, section 1-8.2.3). See “Minimum Required Signage” on page 3-31.
- Separate battery rooms (especially for flooded cell types) that are sealed from adjoining rooms and properly vented to the building exterior are recommended. These conditions may also be required by local codes.
- Where battery systems use a total electrolyte volume greater than 3.79 L (1 gallon), cell assemblies and containment/neutralization provisions **shall** conform with NFPA 111.

**WARNING**

Appropriate signage **SHALL** be present on doors leading to battery rooms and within the room itself, notifying personnel of explosion, chemical and electrical hazards within the area. Appropriate fire extinguisher(s) **SHALL** be present in the battery room, as dictated by local code. See “Fire Protection and Safety” on page 3-20 and applicable subsections.

At sites where batteries constructed with bolt-on terminal connections are used, the following items **shall** be provided:

- Connector bolt wrench (nonconductive)
- Lifting sling and spreader block if applicable
- Container of non-oxidation material for coating electrical connections
- At sites with flooded lead-acid batteries, the following items **shall** be provided:
 - Hydrometer with markings every 10 points
 - Acid-resistant container for storing the hydrometer
 - Thermometer, battery

6.7.3 Battery Backup Duration

Typically, a two hour battery backup provision is standard practice for shelter installations. This is based on the assumption that 2 hours is the nominal amount of time in which a technician would be able to respond and correct a site power problem for most urban locations. For remote sites, 4 hours or more may be necessary to respond and take action.

Battery backup requirements can range from a few minutes to many hours, depending of the system application and customer requirements. Backup of less than one hour is considered to be a high rate of discharge application.

**NOTE**

Because the battery backup typically will not provide for power to the HVAC system, temperature related shutdown (due to temperature shutdown circuitry in repeaters) **shall** be considered in determining the maximum operational period under backup conditions. In some cases, thermal shutdown can occur well before basic battery exhaustion.

6.7.3.1 High Rate of Discharge

If the battery plant will be used in a high rate application, or if an existing plant is to be converted to a high rate application, consult the battery manufacturer because this may require batteries specifically designed for high rate applications. High rate plants may require that the size of hardware used to connect the cell into a string be sufficiently large as to accommodate the additional heat generated by high rates of discharge.

6.7.3.2 Long Duration Backup

Battery backup of many hours may be desired and can be designed for, but may not always be achievable. Long term outages are caused by loss of AC from the utility company and/or the standby generator. During long term outages, the HVAC (heat, ventilation and air conditioning) system is also disabled.

Depending on the site and the equipment being powered by the batteries, significant thermal rise or fall may occur. If the outage persists long enough, thermal shutdown due to loss of HVAC may be the true limiting factor in backup duration. Given the heat generated by the equipment and a potential range of outside ambient conditions, an HVAC contractor should be consulted to determine the amount of time it will take for the site to reach the high or low limits of the equipment's operating temperature range. For worst-case calculations, battery backup durations exceeding this time are not recommended.

6.7.4 Battery Sizing

Battery sizing can be straightforward or fairly complex, depending on the characteristics of the load being backed up. Stationary batteries (those used for fixed locations) are rated in Amp-Hours (AH).

An 8-hour duration represents a rated amperage. The amp hour rating of stationary batteries is generally stated as the number of amps a battery can deliver for an 8-hour period. For example, 100 A for 8 hours is a 800 AH battery. If durations of other than 8 hours are desired, a correction factor must be applied.

Table 6-8 provides the correction factors for several durations. Note that new batteries do not deliver 100% of their rating. It takes several charge/discharge cycles to bring a battery plant to full capacity. Also, as a battery continues to age its capacity gradually falls to 80% of its initial rating, at which point it is considered to be at end of life. These characteristics should be considered when choosing batteries.

Table 6-8 BATTERY RATING CORRECTION FACTORS

1 Hour	2 Hours	4 Hours	6 Hours	8 Hours
1.763	1.378	1.157	1.061	1.0

The DC load for most digital systems can be assumed to be steady-state, as it does not vary (even during busy times). Multiply the load by the backup duration and apply the correction factor, if necessary.

For example, given a load of 32 amps and a backup duration of 4 hours, multiply the load (32) by the duration in hours (4) and the correction factor of 1.157. This means that a battery with at least a 148 amp hour rating will be required for this application.

To calculate battery size, the power required and duration of each change must be known. Graph out the entire discharge profile. When the discharge profile is graphed, divide the discharge into blocks based on duration.

6.7.5 Battery Rating

Batteries **shall** be accurately sized to ensure they will maintain proper voltage for the required time duration. Use worst-case scenarios with respect to age/deterioration, lowest temperature, expected load and the availability of alternate power generators.

6.7.6 Multiple Battery Strings

General practice stipulates that battery types, ratings and service life **shall not** be mixed among a rack. If a site is expanded, then all fresh, similar batteries **shall** be installed and the old batteries removed. A mixture of batteries results in unequal current distribution and charging, and the probability of ongoing power system problems as batteries of different ages fail.

Floor loading, growth and system load are a few of the factors that determine the number of strings of batteries required. All battery backup systems require maintenance. Some of the maintenance operations require the batteries to be off-line. Because there is no way to predict a short duration power interruption, a minimum of two strings of batteries is strongly recommended. This will ensure some amount of battery backup should an interruption occur during battery maintenance.

Too many strings of batteries also presents a problem. Should a fault occur in one cell in one string of batteries, diagnosing and locating the fault becomes more difficult as the number of strings increases. To protect the battery plant from a catastrophic failure of a single string of batteries, overcurrent protection is necessary for each individual string in the plant. The sizing of this protection should be as follows:

System ampacity/Number of battery strings -1 = Required protection

Manufacturer recommendations for the maximum number of strings varies widely. Motorola Solutions recommends that the power system be initially designed for a minimum of two strings and a maximum of six strings of batteries when the system is fully implemented. This will allow some margin for excess growth should the system exceed the anticipated load of a fully implemented system.

6.7.7 Battery Charging

Batteries that have been discharged to a state below full charge must be fully recharged within 24 hours. During this process considerable charging current may flow and flooded cell batteries will give off a higher level of gas than during normal float charge. A float charge must be maintained to keep the battery in a fully charged state. Over or under charging of batteries will cause an increased need for battery maintenance and may greatly shorten the service life of the battery. It is important that the charging system is properly adjusted per the manufacturer's specifications. Overcharging and undercharging alarms **shall** be installed to ensure that battery charging problems are detected quickly.

6.7.8 Battery Temperature Requirements

Battery performance and service life are significantly affected by operating temperature. For full-rated performance and maximum service life, the battery temperature should be maintained close to 24° C (75° F). The battery operating time is reduced as the temperature falls; conversely, the operating time is increased as the temperature rises. However, when batteries are subjected to elevated temperatures the service life of the battery is reduced.

Reference temperature is often overlooked in rating batteries. Battery manufacturers typically use 22.2° C (72° F) as the reference temperature. A battery operated at 0° C (32° F) produces 30% capacity, but lasts for 130% or more of the rated life. Conversely, a battery operated at 38° C (100° F) produces 130% battery capacity, but may last less than 1 year.



NOTE

If building codes do not allow batteries within the same compartment as the climatized radio equipment enclosure, outdoor battery pedestals may have to be protected from direct sunlight or elevated to prevent their burial in snow during winter (where applicable).

6.7.9 Battery Installation

Personal protective equipment, as dictated by battery manufacturer warning statements, **shall** be available within the battery area. A plumbed eyewash station and emergency shower should be provided if practicable.



WARNING

To avoid spilling acid, do not tip batteries. Battery acid can cause severe burns and blindness if it comes into contact with skin or eyes. Wash affected skin or eyes immediately with running water. Seek medical attention immediately.

Jewelry SHALL not be worn while working on batteries.

Installation personnel SHALL wear necessary safety equipment when installing batteries.

Batteries may require a two-person lift. Use proper lifting techniques and equipment to avoid injury.

Insulated tools SHALL be used when installing battery systems.

Battery installation **shall** conform to manufacturer specifications, NFPA 70, and all applicable national, state and local codes. Observe the following cautions when installing batteries:

- Do not slide or drag batteries.
- Because of size, weight and service needs, batteries are normally installed on shelves or racks. In earthquake-prone areas (Moment Magnitude rating 3 or greater), however, seismic racks **shall** be used. Seismic racks **shall** be properly secured to the floor or wall, but **shall not** be secured to both. Seismic racks **shall** be installed exactly as specified by the rack manufacturer.



IMPORTANT

For areas with seismic rating of Moment Magnitude rating 3 or greater, appropriate rack design shall be used. Follow manufacturer's installation requirements.

- Racks and shelves **shall** be constructed to support the total weight of the batteries and other supporting equipment placed on them. Racks and shelves **shall** be assembled in accordance with the manufacturers specifications.
- Battery racks **shall** be bolted to the floor or wall.
- The batteries **shall** be prevented from falling due to accidental movement by installing a rim to prevent tipping or by interconnecting batteries to prevent movement.
- Metal racks **shall** be grounded in accordance with specifications provided in Chapter 5, “Internal Bonding and Grounding (Earthing).”
- Perform calculations to ensure that the floor area will support the total weight of the rack and the batteries. See “Battery Installation” on page 6-36.
- All terminal connections **shall** be tightened to manufacturers' specifications.
- A non-sparking circuit breaker of suitable size to handle maximum load and charging currents **shall** be installed in the ungrounded leg of the circuit to provide overcurrent protection. The current carrying capacity (referred to as “ampacity”) of the circuit breaker **shall not** be greater than the ampacity rating of the circuit conductor. This device may also serve to disconnect the load during battery servicing.
- Circuit conductors, including jumpers between several cells, **shall** be jacketed copper of at least the minimum AWG size permitted for the maximum DC load. Conductor size may need to be larger than that specified to minimize voltage drop between the batteries and the equipment.
- In the U.S., DC conductor jacket colors **shall** be red (floating or ungrounded) and black (grounded). Red and black tape may be applied at each connection, splice or pull box if red and black conductors are not available. These requirements may vary by vendor product and international location.
- Conductors **shall** be enclosed in PVC or metallic conduit or raceway for protection from physical damage and **shall not** be exposed except near terminations.
- Any additional disconnect switches **shall** have an ampacity rating equal to or greater than the circuit protection device.
- Battery terminals **shall** be protectively coated in accordance with manufacturer's specifications.
- Exposed battery terminals should be protected from accidentally contacting metal objects.
- Stationary lead acid batteries **shall** be equipped with an approved spill containment system to prevent damage caused by spilled battery electrolyte whenever electrolyte capacity is greater than 4.8 liters (1 gallon) (see BOCA 307.8.13 and Universal Building Code Article 304.8). The spill containment system **shall** comprise a passive and active neutralization system. See Figure 6-18.



Figure 6-18 Example of Battery Spill Containment System

6.7.10 Battery Maintenance Disconnect

At some time it will be necessary to perform off-line maintenance on the batteries. An individual disconnect **shall** be supplied for each string of batteries for isolating a string from the rest of the system to safely perform battery maintenance. The disconnect device **shall** be such as to prevent arcing upon circuit make/break and prevent any exposed live conductors.

Ensure that the DC supplied by the rectifier is electrically clean enough to supply equipment without the filtering characteristics of the batteries attached. Equipment damage could result if rectifier output has too much ripple.

6.8 Standby Generator Systems

This section describes requirements for backup/standby generators. The purpose of a backup or standby generator is to supply reliable power to critical loads during times when commercial power has failed. It is very important that generators used for this purpose be capable of reliably handling the required loads for the desired time while maintaining proper voltage and frequency. Backup/standby generators are not required to be installed to the same standards as emergency generators. The standards included in this section do not apply to emergency generators or power systems. Emergency power systems are required to comply with NFPA 70-2017, Article 700. Therefore, it is recommended to know and understand the difference between backup/standby generator and emergency generator systems before procuring a generator equipment or installation work.



NOTE

The expected need of having a site supplied with a standby generator should be balanced against the economy of including a generator at the site. It is most likely cost-prohibitive to provide standby generators for large systems utilizing many sites. Typically, only difficult to access or remote location sites are equipped with standby generator power. An “Appleton”-type power connector and a manual transfer switch can be installed at sites not equipped with a generator. In these cases, a portable generator can be conveniently connected to the site if needed.



NOTE

There are certain locations where commercial power is not available and generators must be used for primary power. Primary power generators or generating systems **shall** be rated for continuous duty and **shall**, at a minimum, be installed to the standards covered in this section. All domestic installations **shall** meet NFPA 70-2017 and any local governing codes applicable to continuous duty, primary power generators. Installations performed in non-domestic locations **shall** meet all applicable national and local codes. See NFPA 110 for additional information.

A generator system includes the generator, along with a cooling system, a fuel supply system, a transfer switch and a control panel with required alarms. Liquid fueled generators may incorporate the fuel tank into one housing, such as a base mounted tank. The transfer switch and control panel may also be incorporated into one cabinet. The generator may be placed outside as a stand-alone piece of equipment or inside a building or structure. The location may depend on several factors that include generator size, fuel supply, noise restrictions and space availability. Local codes may additionally dictate the fuel type allowed.

6.9 Generator Output and Derating Considerations

To ensure that the backup generator can handle the power requirements of the equipment at the site, always consider the following factors when calculating generator output power requirements:

- Voltage, phase and load requirements of the equipment to be supplied by the generator must be obtained, including unusual loads such as UPS power supplies and switched power supplies. The customer or an electrical engineer may specify these values.
- Consider site expansion. A 30% expansion factor is not unreasonable.
- Consider worst-case scenarios for generator load, such as all transmitters keyed simultaneously at a trunking site.

- Consider whether the generator load will be three-phase or single-phase. Many generators are rated for operation with a three-phase load and must be derated when working with a single-phase load. If the load is single phase, be certain that the generator is capable of supporting the maximum load while connected in a single-phase configuration. When balancing the single phase loads across three phases, always account for transmitter current.
- Consider physical requirements of the site. Generators may be derated based on operating altitude, type of fuel and operating temperatures.
- The generator **shall not** be used under conditions that could exceed the manufacturer's specifications for the particular generator equipment.

6.9.1 Generator Placement

All generators **shall** have an adequate supply of fresh air to ensure proper operation and extend life. Air is required for safe and efficient combustion as well as to cool the engine and generator. The type of engine cooling is determined by the capacity of the generator. Most generators above 7.5 kW utilize water-cooled engines; generators below 7.5 kW typically use air-cooled engines. The rate of airflow required for cooling is specified by the manufacturer. Manufacturer's guidelines **shall** be followed to ensure proper operation.



NOTE

The type of fuel used for a generator dictates the elevation of the fuel tank relative to the generator. A liquid-fuel generator (diesel or gasoline) will require that the fuel tank be upgrade from the generator fuel inlet such that the generator remains primed. Conversely, because gases rise, an LPG or natural-gas powered generator **shall** be placed upgrade from the fuel source outlet port.

6.9.1.1 Generators Located Indoors

If the generator is to be located inside a separate structure or within the site building, the following requirements **shall** be met:

- Personnel safety and vulnerability of the generator to damage **shall** be considered, especially if the generator is to be installed without a protective housing. Moving engine parts and the exhaust system may be exposed, which could pose a hazard. Guards or shields **shall** be installed on exposed engine parts that could pose a safety hazard to personnel.
- The generator **shall** be located in an area accessible only by authorized personnel.
- Provide adequate spacing for service to the generator in accordance with NFPA 70-2017 and state and local codes (or equivalent). Generally, a minimum spacing of 914 mm (3 ft) on three sides is acceptable.
- Manufacturer's specifications **shall** be followed to ensure proper ventilation, fuel supply and engine exhaust.
- Properly sized air intake and exhaust ports **shall** be installed and maintained. The exhaust air from the radiator area of the generator in most cases is ducted to the outside.
- A louver or shutter should be installed on the exterior of the duct to close off the duct when the generator is not running. The shutter should open automatically when the generator begins operating.
- A motorized louver or shutter should be installed on the air intake to close off the duct when not in use. The shutter should open automatically when the generator begins operating.
- The concrete foundation for the generator should be separate from that of the general structure. An inset sub-foundation set within a well in the overall foundation will help isolate transmitted vibration and noise emanating from the generator.
- Ensure that there is an adequate fresh air supply. Should the fresh air supply not be adequate, air will be drawn through doors or possibly through existing vent pipes, causing a down draft of these vents. This could draw undesirable or potentially harmful fumes or gases back into the room or building. This could be a major concern in manned buildings. Check local codes for recommendations and guidance in this area.
- Fuel supply lines **shall** be no smaller in diameter or of greater length than that specified by the manufacturer. These lines should be routed and installed such that they are protected from potential damage.
- The engine exhaust system pipe and muffler **shall** be no smaller in diameter or of greater length than that specified by the manufacturer.

- In areas where the noise levels exceed 85 dBA, warning signs and hearing protection **shall** be provided.

**IMPORTANT**

Due to the potential of excessive generator heat, the flammability of materials used in the construction of the indoor generator room shall be considered.

6.9.1.2 Generators Located Outdoors

If the generator is to be located outdoors, the following requirements **shall** be met:

- The generator **shall** be enclosed in a housing sufficiently rugged to protect against weather, animal/insect ingress and tampering. This is especially important for the radiator and fuel tank.
- The generator **shall** be enclosed within a fenced area, with adequate distance between the fence and the equipment for servicing.
- A muffler **shall** be used to minimize noise. If the generator is installed near other buildings, a muffler suitable for use in residential areas **shall** be used.
- The engine exhaust **shall** be equipped with a rain cap.
- Locate the generator such that wind will not likely carry dust and moisture into the housing nor exhaust gases into the building.
- Locate the generator such that required ventilation may be achieved. Most generators exhaust air outward through the radiator.
- In colder climates other considerations apply. An engine block heater may be required to keep the engine oil usable.
- Grade relative to fuel source/fuel inlet **shall** be appropriately considered.

6.9.2 Fuel Supply for Generators

Generators may be operated from diesel, liquid or gaseous propane, natural gas, or gasoline fuels. Domestically, state and local codes **shall** be observed because different areas of the country have unique requirements. Fueling requirements in non-domestic locations **shall** meet all applicable national and local codes.

When selecting a generator, determine the standard fuel source for the area and use it whenever practicable to ensure that an adequate fuel supply is available. Where available, utility-provided natural gas provides the most reliable fuel source and releases the installation from concerns regarding fuel tanks.

In general, the following fueling considerations **shall** be observed:

- **Liquid Propane Gas (LPG)** is considered the best all-around backup generator fuel. If practicable, an LPG-configured generator should be considered.
- **Diesel and gaseous propane** are not well-suited for cold climates. Diesel is no longer allowed for new generator systems on US Federal lands due to ground contamination concerns. Diesel requires regular anti-bacterial treatment and water drainage. Diesel must be replaced with fresh fuel periodically.
- **Natural gas** requires a reservoir tank in addition to the supply line. If the supply line is severed, then the generator immediately stops. If natural gas is used, the generator output power will typically be reduced by 20%, as compared to gasoline. Generator output must be derated accordingly in these cases.
- **Gasoline** is a poor fuel for remote generators, with a limited storage life and highly flammable properties. Gasoline generators also have difficulty with remote starting.
- Liquid fuel storage tanks **shall** be equipped with secondary containment capable of retaining 110% (or greater) of the maximum volume of fuel stored.
- The storage tank secondary containment **shall** be designed such that storm water and debris cannot collect inside it.
- All fuel lines or other system components that extend beyond the storage tank secondary containment area **shall** be designed with secondary containment.

- Local Environmental Protection Agency (EPA) rules **shall** be adhered to following a fuel spill. All fuel spills **shall** be cleaned up.
- Fuel storage tanks are required for all fuels except natural gas, which is provided by a utility (however, a storage tank in conjunction with utility-provided natural gas provides additional backup in the case of gas main breakage). Manufacturer specifications as to size and length of fuel supply lines as well as lift **shall** be followed.
- Fuel storage tanks located outside of a structure should be protected from damage and tampering and **shall** be enclosed within a fenced area. In many areas local codes require a double wall construction for the tank or a catch basin to prevent fuel from contaminating the site. Minimum recommended distance between the storage tank and fence is 1.2 m (4 ft); minimum recommended distance between the tank and site building is 3 m (10 ft). See NFPA 58 for additional information.
- Fuel storage tanks **shall** be secured to concrete pads using captive hardware.
- LPG fuel tanks **shall** utilize a fuel vent pressure relief valve. The relief valve vent **shall** be directed away from the tank, sources of ignition and flammable material.
- Fuel lines **shall** be protected within the fuel storage area as well as along the route to the generator. Location and installation of the fuel tank and fuel lines **shall** meet all applicable environmental, building and fire safety codes.
- All generator installations **shall** be equipped with secondary containment capable of retaining 110% of the volume of the largest tank within the containment structure, if the tanks system is a single-wall system. Alternatively, if the tank system is a double-walled system, the system **shall** be designed with interstitial monitoring devices that is capable of detecting a leak in the primary or secondary containment system unless tertiary containment is provided (for example, a convault or equivalent). Special tanks (double wall or fiberglass) and containment barriers are strongly recommended. Earthquake prone areas may require special fuel line considerations. Local codes and manufacturer's recommendations **shall** be followed.
- In potential flood zones, above-ground fuel tanks should be secured with a safety cable around the tank attached to an anchoring device in the soil. This helps prevent the tank from breaking loose and floating away during a flood condition.
- Critical placement and orientation of the tank pressure relief valve is required. This is required, in the case of a fire, to prevent an over-pressure gas release cloud from feeding its own fire.

6.9.3 Transfer Switch

A transfer switch **shall** be installed to perform the switching between commercial power and standby power. This switch is generally collocated with the site electrical service panel. In general, the following considerations need to be observed:

- The switch **shall** have an ampere rating equal to or greater than the ampere rating of the circuits to be transferred.
- The transfer switch is generally located inside a building; however, if the transfer switch is enclosed in an approved watertight housing it may be located outside.
- Many areas require a disconnect switch in the feeder cabling between the generator and the transfer switch. This facilitates generator servicing and provides an additional safety device to prevent AC power backfeed into the commercial service.
- The neutral-ground bond **shall not** be made in the transfer switch.
- For domestic sites, installation of the transfer switch **shall** follow the manufacturer's recommended installation guidelines as well as meet all applicable NFPA 70-2017, national, state and local codes. Installations performed in non-domestic locations **shall** meet manufacturer's recommended installation guidelines, as well as all applicable national and local codes.
- Surge suppression **shall** be installed. See Chapter 7, "Surge Protective Devices."

6.9.4 Electrical Wiring Considerations

When designing the interconnection wiring between the generator, transfer switch and site AC mains, the following considerations **shall** be observed:

- There **shall** be two sets of circuit conductors run between the transfer switch and the generator. One set **shall** be for low voltage control/alarm circuits and the second set for the electrical service. Each set **shall** be installed within its own dedicated conduit/raceway.
- The control/alarm circuits **shall not** be installed within the same conduit or raceway as the electrical service. See NFPA 70-2017, Article 725, for additional information.
- Conduits/raceways **shall** be sized and routed per NFPA 70-2017 (or the equivalent code in non-domestic installations) and other applicable national or local codes.
- A dedicated protected electrical circuit **shall** be provided at the generator for engine/battery heaters and service equipment. If located outside, this circuit **shall** have ground fault protection. See “Outdoor Electrical (Branch Circuits)” on page 6-9.

6.9.5 Installation Plan

Standby generator system installations **shall** be carefully planned and properly installed to ensure proper operation for extended periods. All requirements for the proper location of the generator, properly sized and positioned vents for the required airflow, fuel storage or supply, exhaust system placement and electrical connections **shall** be reviewed by a qualified engineer or inspector to ensure compliance with applicable NFPA 70-2017, national, state and local codes. In general, the following considerations need to be observed:

- Care **shall** be taken to ensure that exhaust gas discharged from the exhaust system **shall** disperse into the open atmosphere and will not be blown or drawn into the building interior. Proper precautions **shall** be taken where generators are installed within or in close proximity to occupied structures.
- Foundation size **shall** be determined based on the geographic area where the system is being installed.
- Door sizes, as existing in the finished structure, **shall** be considered to allow removal/replacement of the largest generator subassembly from within the structure.
- Rain hoods over intake and exhausting vents **shall** be designed to accommodate local extreme environments. Where the potential of high snowfall or drifting is possible, the vent hood **shall** be placed at an appropriate level and directed away from the elements.



NOTE

On radiator cooled generators, cooling air inlet **shall** be at least 1½ times larger than radiator duct receptacle area. Flow of cooling air and heated air should be controlled by automatically operated louvers.

- Earthquake prone areas (Moment Magnitude rating 3 or greater) may require special design and installation features, especially in the area of fuel lines, fuel storage, exhaust system and muffler supports. Appropriate geological information should be consulted regarding seismic considerations.
- For indoor installations, ensure that maximum floor loading will not be exceeded. Shock mounts are recommended and may be required on some installations to minimize vibration transfer.
- Batteries not required for operation of the generator **shall not** be located within a room containing a generator unless the room is properly ventilated.
- Manufacturer's guidelines and specifications to ensure proper air exchange for the generator room **shall** be followed.

6.9.6 Alarms, Meters and Gauges



NOTE

Consideration **shall** be given to assure that remote alarm reporting systems are independent of the power systems they monitor. The reporting system **shall** be such that if the phone line breaks, the primary power source fails, or the common battery bank depletes, then alarms will still be transported.

- All generators **shall** be equipped with an engine high temperature alarm/shutdown and low oil pressure alarm/shutdown.

- All generators **shall** be equipped with an oil pressure gauge.
- Frequency, Voltage and Amp meters are also recommended and should be installed either at the generator control panel or at the transfer switch.
- Additional meter, gauge, remote alarm, engine and battery heater options and needs **shall** be considered. These alarms, if monitored, can provide an early warning to impending problems, thereby reducing cost and down time significantly.

6.9.7 Generator Installation Grounding

All generators, fuel storage tanks above or at grade level and fences discussed within this chapter **shall** be grounded as described in the following subsections.



IMPORTANT

Alarm circuits for external generators shall be surge protected as described in Chapter 7, “Surge Protective Devices”.

6.9.7.1 Indoor Generator Grounding

Generator systems located indoors **shall** be bonded to the internal bonding and grounding system as follows:

- Using the intended chassis grounding connection on the generator, the generator **shall** be bonded to the internal Primary Bonding Bar (PBB) or Secondary Bonding Bar (SBB) in accordance with methods specified in Chapter 5, “Internal Bonding and Grounding (Earthing).”
- A transfer switch (if not part of the generator unit) **shall** be bonded to the interior PBB, SBB, or Internal Perimeter Bonding Bus (IPBB) in accordance with methods specified in Chapter 5, “Internal Bonding and Grounding (Earthing).”

6.9.7.2 Outdoor Generator Grounding

Generator systems located outdoors **shall** be bonded to the external grounding electrode system according to methods specified in “Generators External to the Building” on page 4-93. In addition, the following **shall** be observed:

- Using the intended chassis grounding connection on the generator, the generator **shall** be bonded to the external site Ground Ring in accordance with methods specified in Chapter 4, “External Grounding (Earthing) and Bonding.”
- If a metallic fuel tank is utilized, the fuel tank **shall** be bonded to the external site Ground Ring in accordance with methods specified in “Fuel Tank Bonding” on page 4-112.
- Metallic fencing surrounding the generator installation **shall** be bonded to the external site Ground Ring in accordance with methods specified in Chapter 4, “External Grounding (Earthing) and Bonding.”
- A transfer switch (if not part of the generator unit) is typically installed in the site building or shelter and collocated with the site electrical service panel. In this case, the transfer switch **shall** be bonded to the interior Primary Bonding Bar (PBB) in accordance with methods specified in Chapter 5, “Internal Bonding and Grounding (Earthing).”

6.9.8 Generator Installation

The generator system **shall** be installed using all manufacturer's recommended installation practices. In general, observe the following considerations:

- The manufacturer installation recommendations **shall** be followed.
- In outdoor installations all foundations **shall** be of proper size to support the weight (check local codes for special considerations).
- The generator, fuel tank(s), transfer switch/control panel and all associated components **shall** be securely fastened to the intended foundations.
- Fuel lines **shall** be adequately secured, protected and free of leaks.
- All parts of the system **shall** be installed in such a manner that it **shall** be easily serviceable without undue safety risk while the equipment is operational.

- Installations in earthquake prone areas (Moment Magnitude rating 3 or greater) may require additional fuel, exhaust system and muffler supports. Manufacturer recommendations and local codes **shall** be followed in these areas.
- In earthquake prone areas (Moment Magnitude rating 3 or greater), it is recommended that standby generators be installed on vibration isolators, with flexible cables used for electrical and grounding, and flexible tubing be provided for fuel systems.

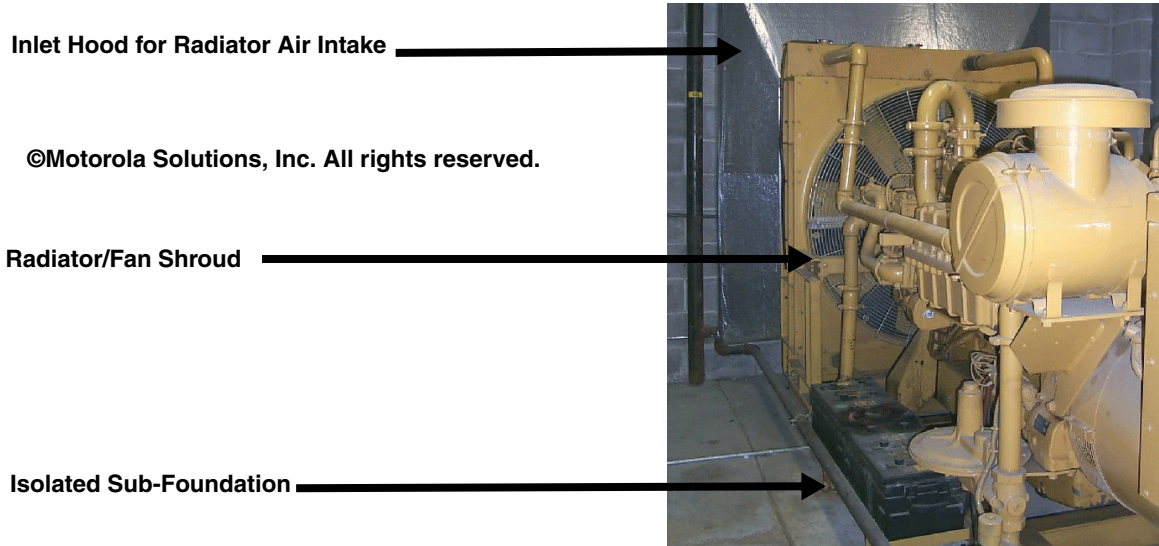

Figure 6-19 Completed Installation of Typical Generator System

6.9.9 Generator Startup

Most generators ship without oil and coolant. Many times fuel lines are not connected. An authorized manufacturer's service representative should be used to review the installation, prepare and start the generator. Observe the following considerations:

- The manufacturer startup recommendations **shall** be followed.
- All fluid levels **shall** be checked to ensure adequate supply prior to actual startup.
- The generator **shall** be checked for proper voltage and frequency while operating with and without load. These **shall** be within manufacturer's specifications or no greater than a 3% variation from rated voltages and 5% overall variation from specified frequency.
- Setting of all controls within the transfer switch/control panel **shall** be verified and checked to ensure proper load pickup, transfer, re-transfer and shut down.
- The charge rate of the battery charger should be checked.
- The exercise clock should be set and proper operation should be verified. The exercise clock **shall** be set to exercise the generator at a minimum of 30 minutes every 7 days. It is strongly recommended to exercise the generator under full load.
- All alarm connections **shall** be verified and functions tested.
- The fuel system and exhaust system **shall** be checked to ensure there are no leaks.
- Check to ensure that all safety shields and covers are in place.
- If a UPS system is employed in this configuration, tests **shall** be conducted to ensure the UPS functions properly when being fed by the generator. If a problem occurs, frequency and voltage tolerances may need to be reviewed.

6.9.10 Generator Safety

In general, the following safety precautions **shall** be observed:

- All manufacturer's safety guidelines **shall** be followed during installation and operation.

- All moving parts **shall** be enclosed or protected.
- Safety shields and covers **shall** be in place except as necessary for service.
- Hot surfaces such as engine exhaust pipes and mufflers **shall** be protected to ensure that there is no accidental contact by foreign material or persons.
- “No Smoking”, “Caution: Hearing Protection Required”, and “Automatic equipment, may self-start” signs **shall** be posted within a generator room or adjacent to a generator which is located in a room with other equipment.
- Points where exhaust system components pass through walls **shall** have approved feedthrough thimbles installed.
- Fuel lines **shall** be protected from accidental damage.
- Electrical circuits **shall not** be exposed.
- Ensure that exhaust gases disperse and are not drawn back into the interior of the building.
- Ensure that generators installed in earthquake prone areas meet all safety requirements for an installation in that area.

THIS PAGE INTENTIONALLY LEFT BLANK.

Surge Protective Devices

This chapter includes the following topics:

- “Introduction to Surge Protection” on page 7-1
- “Definitions for Surge Protection” on page 7-5
- “Conformance with UL 1449 4th Edition” on page 7-8
- “Technologies Available” on page 7-9
- “AC Power Surge Protective Devices (SPD) Requirements” on page 7-9
- “AC Power SPD Requirements” on page 7-20
- “Telephony, Data, Signaling, Alarm and Network Circuit Protection” on page 7-21
- “Closed Circuit Television and Security” on page 7-34
- “Broadband Point-to-Point and Multi-point Wireless Links” on page 7-35
- “Satellite and Television Broadband Services” on page 7-38
- “Direct Current Systems Surge Protection” on page 7-52
- “AC Power Line SPD Test Certification Requirements” on page 7-56
- “Electromagnetic Pulse (EMP)” on page 7-63



NOTE

The terms Surge Protective Device (SPD), Surge Protection Device (SPD) and Transient Voltage Surge Suppressor (TVSS) are used interchangeably. IEEE C62.45 and UL defines TVSS as an SPD.

7.1 Introduction to Surge Protection

Surges and transient power anomalies are potentially destructive electrical disturbances, the most damaging being overvoltage occurrences and short duration overvoltage events. Sometimes referred to as “spikes,” high-energy transient power anomalies can arise from inductive load switching or other events within the power system or capacitive and inductive coupling from environmental events such as nearby lightning activity. Environmental and inductive power anomalies are wide-band occurrences with a frequency range from close to DC to well into the RF high frequency spectrum.

Surge Protective Devices (SPD) are required for all communication sites, enclosures and facilities housing critical electronics, networking and RF equipment (see ATIS-0600321.2015, ATIS-0600334.2013, IEEE 1692-2011 and NFPA 780-2017, section 4.20). The installation of SPDs to mitigate spurious over voltages occurring on copper conductors as they enter the communications enclosure or shelter and in line with critical network equipment, promotes network integrity. Surge protection reduces risk of injury to personnel, physical equipment damage and loss of operations (equipment and/or system down time). Although lightning can cause the most visible damage, it is not the predominant cause of transient voltages.



IMPORTANT

All electrically conductive points of entry (for example, AC power, telephone, LAN, signal/control and RF) into a site shall be protected from surges using a Surge Protective Device (SPD).

Transient voltage sources include, but are not limited to, the following (see IEEE C62.41.1-2002 and MIL STD 188-125-1 for more information):

- Power company switching
- Generator transfer
- Shared commercial feeders with poor line regulation
- Load switching
- Fault currents
- HVAC units
- Heating elements
- Power tools
- Electric motors
- Fluorescent lighting
- Elevators
- Switching of inductive loads
- Lightning activity
- Electromagnetic Pulse (EMP)

There are four major site entrances for surges that require individual attention in order to effectively protect a site and reduce the probability of damage.

- AC Power
 - Main service
 - External branch circuits or feeders
 - Generator
- Telephone/Data
 - Data circuits
 - Broadband
 - LAN
 - Control
 - Security and card access
 - CCTV
- RF Cabling
 - Antenna transmit and receive lines
 - GPS
 - Cable TV service
- Tower Lighting Systems

Effective grounding (earthing) alone will not protect a communications facility from damage due to surges, transients and lightning. However, an effective combination of facility grounding, equipment bonding and properly installed Surge Protective Devices (SPDs) on all circuit conductors entering/exiting the equipment area can significantly help maximize total site protection.

**IMPORTANT**

Transient Voltage Surge Suppression (TVSS) techniques using Surge Protective Devices (SPD) alone are not enough to adequately protect a communications site. Proper grounding (earthing) and bonding shall be incorporated at a communications site in order to provide an adequate level of protection. See Chapter 4, “External Grounding (Earthing) and Bonding”, and Chapter 5, “Internal Bonding and Grounding (Earthing)”, for bonding and grounding details and requirements.

The requirements presented in this chapter will provide a suitable level of protection for communications equipment and sites in most areas. Areas subject to more severe lightning activity will require additional SPD design considerations that are beyond the scope of this chapter (consultation with Motorola Solutions Engineering or other engineering firm is recommended in these cases).

The ultimate goal of surge suppression in low voltage circuits (less than 1000 volts) is to keep communications sites and systems operating reliably (system availability). Failure of a single SPD at a communications site would leave the site vulnerable to further damage. To maintain a backup level of protection, it may be necessary to install a redundant SPD.

Figure 7-1 shows the minimum AC SPD installation complement for a typical communications facility.

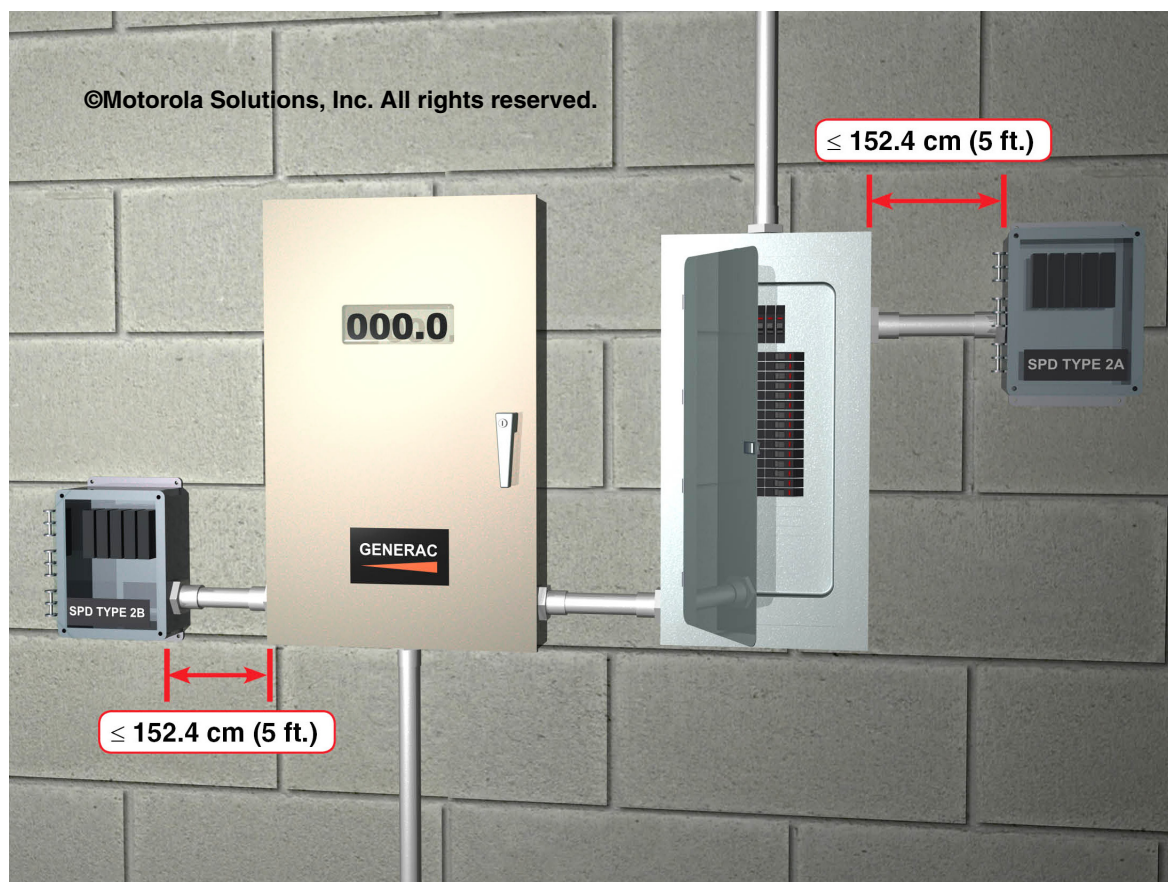
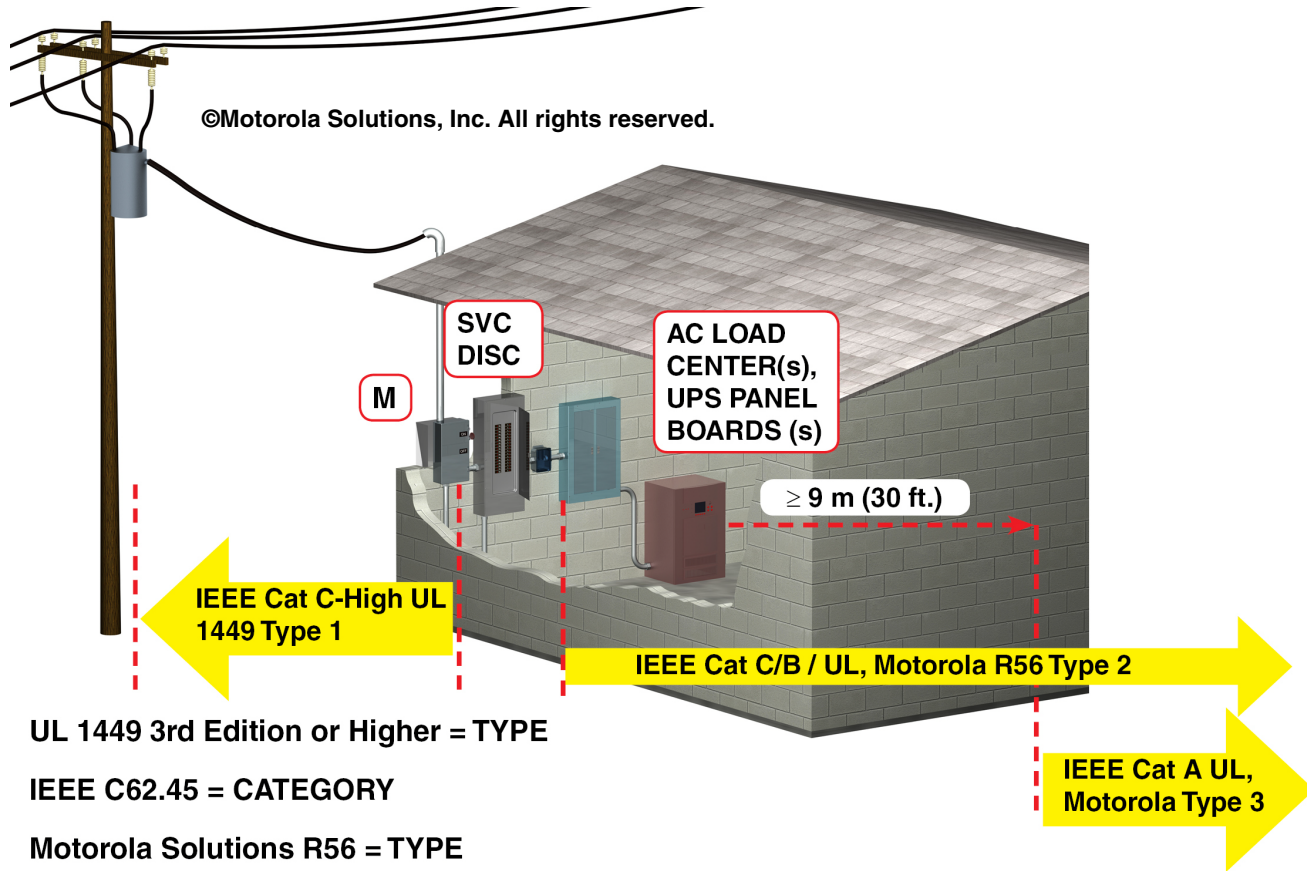

Figure 7-1 Minimum AC Surge Protection Installation Complement for a Typical Communications Site



UL 1449 3rd Edition or Higher = TYPE

IEEE C62.45 = CATEGORY

Motorola Solutions R56 = TYPE

Note: UL 1449 Type 1 is not recognized by Motorola. SPDs may be listed as Type 1 and Type 2, but shall meet the minimum specifications of this chapter.

Figure 7-2 AC Surge Protection Category, Location and Type Definitions

UL	3	2	1	
IEEE	A	B	C	C_{High}
R56	3	2A/B	X	X

©Motorola Solutions, Inc. All rights reserved.

Figure 7-3 AC Surge Protection Category, Location and Type Definitions

7.2 Definitions for Surge Protection

The following terms are defined as follows in this chapter:

1.2/50 Voltage Wave: Voltage surge with a virtual front time of 1.2 μs and a half-value of 50 μs delivered across an open circuit.

10/1000 Voltage Wave: Voltage surge with a virtual front time of 10 μs and a half-value of 1000 μs delivered across an open circuit.

8/20 Current Wave: Current surge with a virtual front time of 8 μs and a half-value of 20 μs delivered into a short circuit.

Combination Wave: A surge delivered by a generator which has the inherent capability of applying a 1.2/50 μs voltage wave across an open circuit and delivering an 8/20 μs current wave into a short circuit. The wave is determined by the generators source impedance. Source impedance may vary slightly at higher voltages through the EUT, but for the purpose of this chapter the source impedance **shall** be 2Ω .

Common Mode: Voltages appearing between line or neutral conductors and ground (L-G or N-G).

Customer edge Premises Equipment (CePE): The point where the NID, Microwave or broadband switch interfaces with the Network Management Plane (Site Link).

Electromagnetic Energy (EME): Reflected or emitted electrical or magnetic waveshapes traveling through space and Earth's atmosphere. EME ranges from just above DC to very high broadband frequency.

Electromagnetic Pulse (EMP): EMP devices are intended to attenuate unwanted RF signals generated by electromagnetic sources, including High Altitude Electromagnetic Pulse (HEMP) or dirty bomb detonation. Although SPDs incorporating capacitors, inductors and Silicon Avalanche (SAD) technology are integral components of EMP surge mitigation, design is a specialized area mostly beyond the scope of this standard.

Equipment Under Test (EUT): Refers to the SPD being tested.

Ethernet Physical Layer (PHY): The physical layer component of the Ethernet circuit, the PHY layer encompasses the physical media interfaces and several magnitudes of speed (1 Mbit/s to 100 Gbit/s) and the physical medium ranging from coaxial cable to twisted pair and optical fiber. In general, network protocol stack software will work similarly on all physical layers.

Fault Current: The current from the connected power system that flows in a short circuit.

Maximum Continuous Operating Voltage (MCOV): The maximum continuous root mean square (rms) value of the power frequency voltage that may be continually applied to the mode of protection of an SPD.

Measured Limiting Voltage: A UL term for the maximum magnitude of voltage, measured at the leads, terminals, receptacle contacts and similar locations after the application of an impulse of specified waveshape and amplitude.

Modes of Protection: Electrical paths where the SPD offers defense against transient overvoltages. For example (L-N), (L-L), (L-G) or (N-G).

Network Interface Device (NID): A device that serves as the demarcation point between the carrier's local loop and the customer's premises wiring (CePE) (Smart Jack).

Normal Mode: Voltage appearing between line and neutral (L-N) and line to line (L-L) conductors.

Nominal Discharge Current (I_n): Peak value of the current through the SPD having a current waveshape of 8/20 μs (IEEE C62.41-2002), where the SPD remains functional after 400 impulses (see " I_n (Nominal Current Test)" on page 7-57).

Nominal System Voltage: A normal value assigned to designate a system of a given voltage class in accordance with ANSI C84.1, Table 1. Nominal voltage for the purpose of this standard is addressed in Table 7-2.

Permanently Connected (PC): An SPD provided with terminals or leads for field connection to wiring systems in accordance with NFPA 70-2017.

Power over Ethernet (PoE): Several standardized or ad-hoc systems which pass electrical power along with data on twisted pair Ethernet cabling. Typically DC -48, but may be higher voltage depending on the cable used for the application.

Protected Multiple Earthed systems (PME): AC System (TN-C-S), or a continuous metallic earth conductor existing from the star point of the supply transformer to the earthing terminal of the installation, it will run throughout in parallel with the installation neutral, which will be at the same potential. The neutral and earth conductors are kept separate within the

installation: the main earthing terminal is bonded to the incoming combined earth and neutral conductor by the electrical utility (with slight difference, PME is also known as MEN).

Shielded Twisted Pair (STP): Protects the transmission line from Electromagnetic Interference (EMI) leaking into or out of the cable. STP cabling is often used in Ethernet networks, especially fast data rate Ethernets.

Short Circuit Current Rating (SCCR): Is the maximum short-circuit current a component or assembly can safely withstand when protected by a specific overcurrent protective device(s) or for a specified time. Adequate short-circuit current rating is required per NFPA 70-2017, Article 110.10.

Surge: A transient fast wave of current, potential or power in an electric circuit. For the purposes of this standard, surges do not include Temporary Over Voltages (TOV) consisting of an increase in power frequency voltage lasting for several cycles.

Surge Protective Device (SPD): A device composed of at least one non-linear component (See “Technologies Available” on page 7-9) and intended for limiting surge voltages on equipment by diverting or limiting surge voltages and is capable of repeating these functions as specified. SPDs were previously called TVSS. A device that is intended to limit transient over voltages and divert surge currents (IEEE 1100-2005). May also be referred to as Surge Protection Device.

SPD Disconnect: Device(s) internal or external, required for disconnecting an SPD from the power system. Devices may provide overcurrent (fuse or circuit breaker) and/or thermal response protection.

Terminal Equipment (TE): Carrier owned equipment edge or Network Control Plane of a Public Switched Telephone Network (PSTN).

Transient Voltage Surge Suppressor (TVSS): A device that functions as an SPD or surge suppressor (IEEE 1100-2005). The term TVSS has generally been retired and replaced with the term SPD.

Twisted Pair (TP): Two conductors of a single circuit are twisted together for the purposes of canceling Electromagnetic Interference (EMI) from external sources; for instance, electromagnetic radiation from Unshielded Twisted Pair (UTP) cables and crosstalk between neighboring pairs. See Chapter 9, “Equipment Installation”, for Plenum and Riser rated cabling requirements.

Unshielded Twisted Pair (UTP): General purpose copper telephony cable with TP circuits wrapped in an unshielded insulated cover. UTP is for internal use only and **shall not** be used for any outside plant purposes.

Voltage Protection Rating (VPR): A rating selected from a list of preferred values normally for each mode of protection. For the purpose of this standard, VPR is established for (L-N) surges only, using a combination waveform as specified in ANSI/IEEE C62.45 - 2002, 8/20 μ s, 6kV/3kA.

Voltage Switching Type SPDs: An SPD that has a high impedance when no surge is present, but can switch suddenly in impedance to a low value in response to a voltage surge. Examples include spark gap gas tubes (GDT) and silicon rectifiers. These are devices that “crowbar” the line and are not approved for AC surge protection by Motorola Solutions.



NOTE

Common Mode AC power surge suppression devices are applicable where Protective Multiple Earth Neutral (PME) or Multiple Earth Neutral (MEN) distribution are utilized. PME consists of a continuous metallic earth system from the star point of the supply transformer to the earthing terminal of the installation. It will run throughout, in parallel with, the installation neutral conductor at the same earth potential (see Figure 7-4).

IEC 60364 recognizes five earthing systems:

- Terra Neutral-Separate (TN-S)
- Terra Neutral-Combined-Separate (TN-C-S)
- Terra Terra (TT)
- Terra Neutral-Combined (TN-C)
- Isolated Terra (IT)

The focus of this chapter is TN-C-S and TN-S, low voltage AC distribution systems less than or equal to 1000 volts.

NOTE

France, Denmark and Japan are TT systems. Older T-N-S (two-wire) distribution remains in some parts of Europe, Africa and the Middle East. Two-wire distribution should not be used to facilitate power to Motorola Solutions network equipment without the use of an onsite isolation transformer in order to create the Protective Earth (PE).

Figure 7-4 shows an example of TN-C-S Protective Multiple Earth Neutral (PME) or Multiple Earth Neutral (MEN).

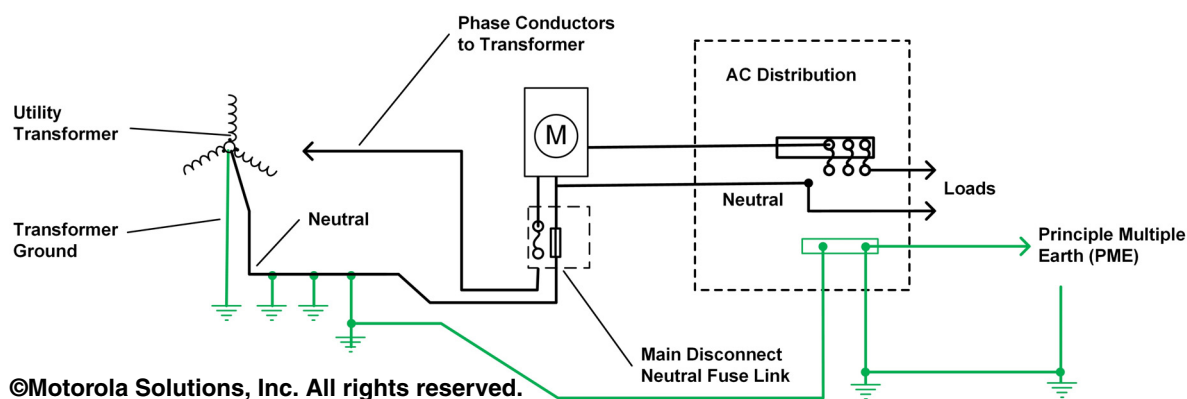

Figure 7-4 TN-C-S Protective Multiple Earth or Multiple Earth Neutral

Figure 7-5 shows an example of TN-S separated earthing.

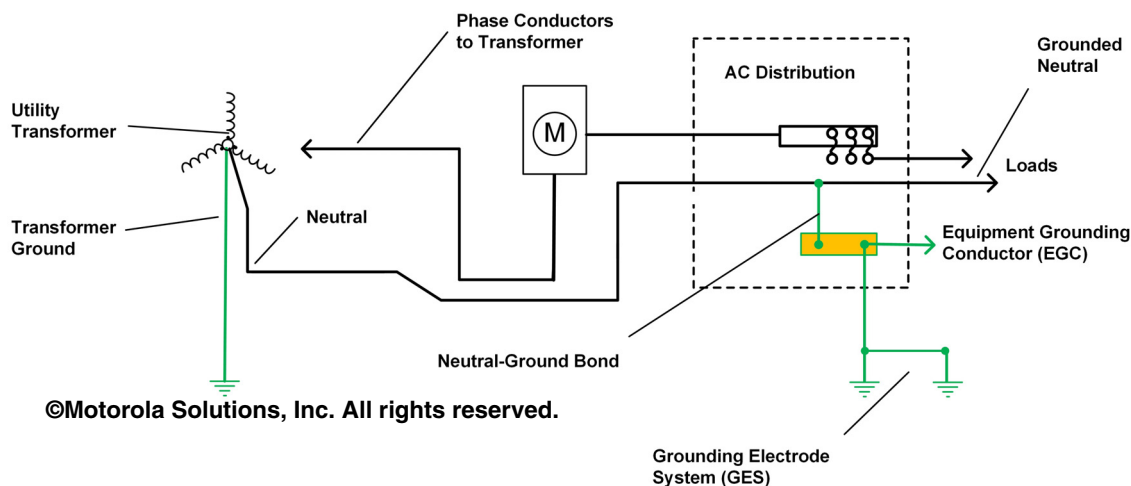

Figure 7-5 TN-S Separated Earth Neutral North America

NOTE

The following definitions apply to Figures 7-4 and 7-5: C = Combined; I = Isolated; N = Neutral; S = Separate; and T = Terra.

7.3 Conformance with UL 1449 4th Edition

Underwriters Laboratories standard 1449 (UL 1449) is the primary recognized safety standard for AC Surge Protective Devices (SPDs). It describes the materials and installation requirements for surge protective devices used for the protection of AC electrical circuits. The standard, updated in 2014, is published as UL 1449 4th edition and contains both safety and performance requirements for AC SPDs that are applicable to this standard. UL 1449 4th edition, effective August 2015, supersedes preceding editions.

The following is a summary of the UL 1449 3rd edition (2009) changes:

- **Suppressed Voltage Rating (SVR) is now Voltage Protection Rating (VPR).** The SPD let-through voltage is now measured as it is subjected to an IEEE defined 6kV/3kA “combination waveform”. This is a higher current test than the previous version and translates to VPR numbers that are generally higher than the SVR test numbers.
- **Nominal Discharge Current (I_n):** The SPD’s Nominal Discharge Current capability, up to 20kA, is now reported with the specifications of the suppressor and on its labeling.
- **Suppressor Categories:** The new standard categorizes SPDs as one of four designated types based on whether or not they are a component and where within an electrical distribution they are to be installed.
 - **UL Type 1** suppression products, also known as “Surge Arrestors”, are permanently connected SPDs demonstrating a higher level of resistance to electrical fault. Used in addition to fault protection in the meter socket and main disconnect, a Type 1 listed device may be installed on the line side or the load side of the electrical disconnect as supplemental protection for electro-mechanical switch gear. Type 1 SPDs are not suitable replacements for **Type 2A**, **Type 2B** or **Type 3** SPDs.
 - **UL Type 2** suppression products are those that were formerly referred to as TVSS equipment. They are permanently connected SPDs intended for installation on the load side of the main circuit breaker or other type of overcurrent protector, including those that are intended to install upon the branch distribution panels. Motorola **Type 2A SAD/ MOV** and **Type 2B MOV** SPDs **shall** be UL Type 2 listed.
 - **UL Type 3** devices referred to as Point Of Utilization (POU) SPDs. This equipment is intended to be installed at 9.144 m (30 ft) of conductor length away from the electrical distribution panel. Type 3 suppressors include cord connected products, direct plug-in suppressors, receptacle type SPDs and surge suppressors that are intended to be installed directly upon the equipment to be protected.
 - **UL Type 4** suppressors are SPD components and component assemblies that may be UL recognized when incorporated into the body of a UL listed load center or cabinet. UL Type 4 SPDs **shall** comply with the minimum design and test specifications of this chapter, for the given application location.
- **Extended Scope:** Effective August 2014, 4th edition UL 1449 governs suppression products designed for up to 1000 V.



NOTE

The SPD Type terminology used in this manual aligns with the UL 1449 terminology.



NOTE

Effective August 2015, UL 1449 3rd edition was superseded by UL1449 4th edition. AC SPDs approved for the North America market, including Canada and Mexico, **shall** be listed devices in good standing with UL/CUL and **shall** exhibit a current UL file number. SPDs approved for international markets, or outside the jurisdiction of NFPA 70-2017, **shall** comply with the Authority Having Jurisdiction (AHJ).



NOTE

UL Type 1 SPDs are not required by Motorola Solutions and **shall not** be supplemented in place of Type 2A or Type 2B SPDs approved by Motorola Solutions. The highest measure of a surge protective product is voltage let-through according to Category and Location as established by IEEE C62.41-2002 and IEEE C62.45-2002.

7.4 Technologies Available

Several major types of SPD technologies are available today. The most common and most reliable are the Metal Oxide Varistor (MOV) and the Silicon Avalanche Diode (SAD) devices. These devices are ideal for protection of power and telephony or data circuits because of their fast response time and high energy handling capability. Other components (such as gas discharge tubes, spark gaps, surge relays, capacitors and inductors), although somewhat effective in specific applications, are not acceptable as power, telephony or data circuit SPDs at communications facilities, because the typical response time is too slow.

It may be necessary to use more than one type of component in a protective device to obtain the best possible combination of SPD characteristics. The most common combination forming a “hybrid circuit” incorporates a high current but slower-acting component with a faster-acting but lower-power rated component. For AC power, this is typically a coordinated MOV and SAD combination.



CAUTION

Gap or Crowbar Type SPDs **shall not** be used as AC power line surge suppression, except where Common Mode (L-G, N-G) may be necessary. GAP, Silicon Carbide and Carbon Block surge components **shall not** be used for Normal Mode (L-L, L-N) AC line surge protection. These components will disconnect power from the load, resulting in reboots or requiring human interaction.

7.5 AC Power Surge Protective Devices (SPD) Requirements

Requirements for Motorola Solutions approved AC surge protection are detailed in the AC surge test requirements matrix (see “AC Power Line SPD Test Certification Requirements” on page 7-56 and Table 7-1). AC SPDs are low impedance circuits, which by design limit overvoltage anomalies from reaching sensitive loads and shunting overcurrent through the neutral conductor to earth. Normal Mode surge events (L-L and L-N) are commonplace, having a maximum potential of 6kV/3kA (IEEE C62.41-2002).

SPDs are required on all power feeders to and from communications facilities (see IEEE 1692-2011, section 11; NFPA 780-2017, section 4.20; NWSM 30-4106, section 2.1; and TIA-607-C). All devices **shall** be installed per the manufacturer’s installation instructions.

The facility grounding and bonding systems **shall** be properly implemented to help ensure that the electrical service, all surge suppression devices and the communications system components within the equipment area are at the same ground potential (see Chapter 4, “External Grounding (Earthing) and Bonding”, and Chapter 5, “Internal Bonding and Grounding (Earthing)”). This is critically important to help ensure maximum safety of personnel and maximum effectiveness of the SPDs.

An important design philosophy is that the AC power SPDs **shall not** cause interruptions to the site power when it operates. Therefore, to reduce this probability, all AC power SPDs **shall** be designed for and installed as parallel devices. A suitable disconnecting means **shall** be provided to permit servicing. Alarms or remote monitoring to report a device failure are recommended.



IMPORTANT

All AC power SPDs used within the United States shall be UL 1449, 4th edition (or later revision) listed (see NFPA 70-2017, Article 285.6).

7.5.1 AC SPD Requirements Based on Facility Description

Table 7-1 specifies the minimum AC power SPD requirements for various communications facilities. The voltage and phase requirements are site specific and depend on the electrical service characteristics for the specific location.

Table 7-1 REQUIRED SURGE PROTECTIVE DEVICES BY SERVICE TYPES

Service Type	Main Disconnect	ATS	Main Distribution Panelboard	Equipment Room Subpanel	Equipment (if at least 9.144 m (30 ft) from panelboard)
Standalone Building or Shelter without Generator					
Main service disconnect and all panelboards located within the same shelter, room or equipment area	-	-	Type 2A	-	Type 3 (see Important note following table)
Standalone Building or Shelter with Generator					
Main service disconnect and all panelboards located within the same shelter, room or equipment area	Type 2B (or 2A) (either location is acceptable)		Type 2A	-	Type 3 (see Important note following table)
Standalone Building or Shelter without Generator Main Service Disconnect Located Remotely from Equipment Building (greater than 3 m (10 ft))					
Utility H Frame or Pole at fence or property line	Type 2B (or 2A)	-	Type 2A	-	Type 3 (see Important note following table)
Main Building					
Utility Power Building					
Separately Derived System (for example, transformer) installed at equipment building					
Standalone Building or Shelter with Generator Main Service Disconnect Located Remotely from Equipment Building (greater than 3 m (10 ft.))					
Utility H Frame or Pole at fence or property line	-	Type 2B (or 2A)	Type 2A	-	Type 3 (see Important note following table)
Main Building (for example, Dispatch Center or Emergency Operations Center (EOC) that provides power to an exterior radio shelter)	Type 2B (or 2A) recommended to protect main building				
Detached Utility Power Building	-				
Separately Derived System (for example, transformer) installed at equipment building	-				
Equipment Area Located within a Larger Structure with Generator					
Main service disconnect located in another part of same structure	Type 2B (or 2A) (either location is acceptable)		-	Type 2A	Type 3 (see Important note following table)

Table 7-1 REQUIRED SURGE PROTECTIVE DEVICES BY SERVICE TYPES (CONTINUED)

Service Type	Main Disconnect	ATS	Main Distribution Panelboard	Equipment Room Subpanel	Equipment (if at least 9.144 m (30 ft) from panelboard)
Remote or Detached Communications Structure (for example, prefabricated equipment shelter or outdoor cabinet) Provided Power from a Main Building - Backup Power Source Located in Main Building					
Generator backed feeder	Type 2A or 2B (For system availability, an SPD is recommended on the main building service, UPS and generator.)	-	Type 2A or 2B (on distribution panel in main building that provides power to the remote communications structure if not already adequately protected at main disconnect)	Type 2A (installed at remote building distribution panel)	Type 3 (see Important note following table)
Generator and UPS backed feeder					
NOTE: Consultation with Motorola Solutions Engineering or other engineering firm is recommended for these installation types.					
Standalone Temporary or Movable Sites (Cell on Wheels - COW)					
Feeder (no generator backup)	-	-	Type 2A	-	-
Generator backed feeder					
Dispatch Center					
	As required for the site type			Type 2A	Type 3 (for electronic equipment installed at operator position)

**IMPORTANT**

For Type 3 SPDs, the following requirements and guidelines apply:

Type 3 SPDs for critical loads are recommended where the critical loads are located between 9.144m (30 ft) and 15.2 m (50 ft) from the neutral-ground (N-G) bond.

Type 3 SPDs for critical loads are required for geographic locations of high-lightning activity, where the critical loads are located at least 9.144 m (30 ft) from the N-G bond.

Type 3 SPDs for critical loads are required for all geographic locations where the critical loads are located at least 15.2m (50 ft) from the N-G bond.

A Type 3 SPD is recommended for all loads located greater than 15.2 m (50 ft) from the N-G bond.

**NOTE**

High-lightning areas are defined as areas with lightning flash density greater than 2 flashes/km²/year. See “Lightning Activity and Exposure” on page 4-3 for more information.

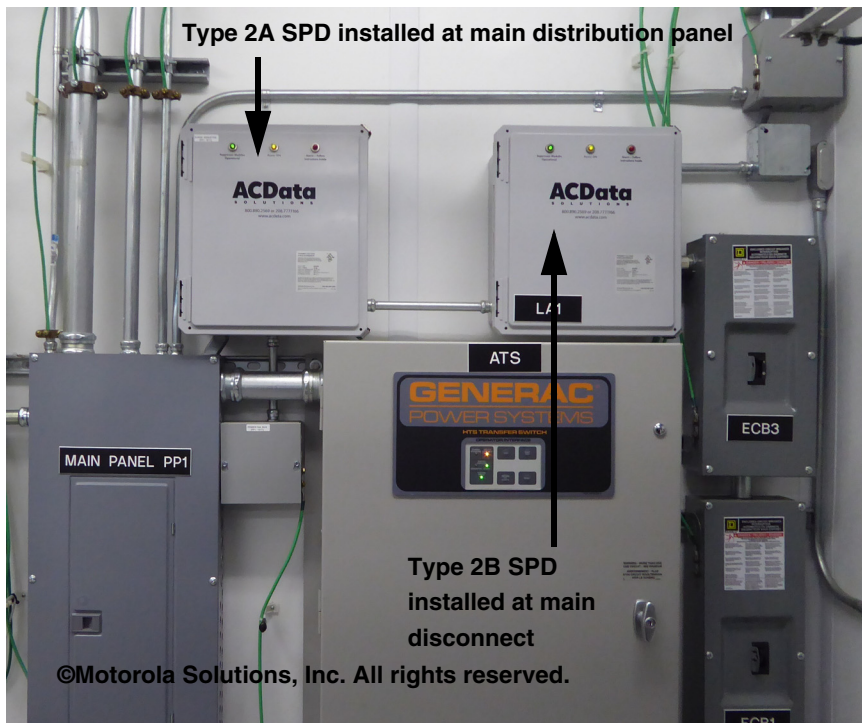

Figure 7-6 Example of AC SPD Installation at Typical Communications Site

7.5.2 Motorola Solutions Definition of SPD Types

Surge Protective Devices (SPD) used for AC power protection referenced in this section are defined as Type 2A (SAD/MOV), Type 2B (MOV) or Type 3 and are defined in this section and its subsections. See Table 7-2 for required specifications for various SPDs.

7.5.2.1 Type 2A (SAD/MOV) Surge Protective Device

Type 2A (SAD/MOV) SPD provides protection for the service entrance and all sub-panel locations within the same equipment room. The requirements are as follows:

- The device **shall** consist of primary modules using Silicon Avalanche Diode (SAD) technology and secondary modules using Metal Oxide Varistor (MOV) technology.
- The SPD **shall** be listed to UL 1449, 4th edition. A test report from a Nationally Recognized Testing Laboratory (NRTL), National Voluntary Laboratory Accreditation Program (NAVLAP), A2LA, or a certified UL client testing data laboratory detailing the procedures used, and the results obtained **shall** be made available to Motorola Solutions for approval.
- The SPD **shall** be a permanently connected, one-port or parallel configuration. See UL 1449 4th edition, section 39A.
- The suppression components **shall** be voltage limiting type. Voltage switching components **shall not** be utilized as a suppression element in the SPD.
- The enclosure rating of the SPD **shall** be NEMA 4 or higher (NWSM 30-41006.2014, section 2.5.2.2).
- The environmental parameters of the SPD are as follows:
 - Operating temperature range: -40° C to +65 °C (-40° F to +149° F)
 - Storage temperature range: -40°C to +65° C (-40° F to +149° F)
 - Operating humidity range: 0-95%, non-condensing
 - Altitude range: -152.4 m to 4572 m (-500 ft to +15,000 ft)

- Electrical connection to the SPD **shall** be made using a 16 mm² csa (#6 AWG) or larger conductor. Per NFPA 70-2017, Article 110, the conductor size **shall** match the breaker size.
- Each SPD **shall** have indicator lamps on or visible from the front of the device showing that power is applied and that the protection integrity has not been compromised.
- The SPD **shall** include the capability for remote monitoring. Such as form “C” dry contacts or SNMP traps. The device **shall** indicate when there is an input power failure or the integrity of any module has been compromised.
 - A device using SNMP traps will indicate power failure by a loss of communications in the SNMP managing device.
 - Form C contacts **shall** be isolated from the AC power circuitry to safeguard the alarm circuit or reporting device should there be a catastrophic event.
 - Connection to the remote monitoring contacts of the SPD **shall** utilize 0.34 mm² (#22 AWG) or larger conductors.
- Except in Protected Multiple Earth (PME) systems, suppression modules **shall not** be connected between any phase conductor or neutral conductor and the equipment grounding conductor or ground (L-G, Common Mode Neutral to Ground).
- The primary module(s) **shall** consist of a SAD module(s) providing 20kA per phase, per polarity, minimum energy absorption. See “Impulse Surge Durability Test Requirements” on page 7-57 for Motorola Solutions certification requirements.
- The secondary module(s) **shall** consist of a Metal Oxide Varistor(s) (MOV) module(s). See “Impulse Surge Durability Test Requirements” on page 7-57 for Motorola Solutions certification requirements.
- The minimum pulse life or durability requirements and the voltage protection level **shall** be as specified in Table 7-2 for a Type 2A device.
- SPD **shall** be properly selected based on the operating voltage and number of phases of the circuits to be protected.
- Each module or sub assembly **shall** be modular in design to allow for easy field replacement.
- The SPD **shall** use integral overcurrent protective devices and **shall** have a minimum Short Circuit Current Rating (SCCR) of 25,000 amperes, as defined by UL 1449, 4th edition, section 44.2.
- The manufacturer declared Nominal Discharge Current value (I_n) for Motorola Type 2A and Type 2B **shall** be 20kA, (L-L) (L-N), as defined by UL 1449 4th edition 40.7.1, using 8/20 μ s waveshape, per IEEE C62.45-2002.
 - **Exception:** A generator that can be calibrated to produce 8/20 μ s waveform with the Equipment Under Test (EUT) in the circuit is considered acceptable.
- The SPD **shall** have a Voltage Protection Rating (VPR) (at the nominal discharge current of 10,000 amperes) not to exceed 800 V_p (L-N), 1000 V_p (L-L) at 6kV/10kA-8/20 μ s, per IEEE C62.45-2002.
 - Voltage Protection Rating (VPR) varies according to Nominal System Voltage (NSV), see Table 7-2 for NSV greater than 120V.
- Test points are measured using specified conductor size at a distance of 150 mm (6 in.) outside of the enclosure.
- Type 2A Maximum Continuous Operating Voltage (MCOV) **shall not** exceed 138V (L-N) for 120V_{rms} service voltage. See Table 7-2 for higher voltage services.



Figure 7-7 Example of Type 2A SPD Installed at Distribution Panel

7.5.2.2 Type 2B (MOV) Surge Protective Device

Type 2B SPDs provide protection for the service entrance locations within the same equipment room. The requirements are as follows:

- The device **shall** consist of primary modules using Metal Oxide Varistor (MOV) technology.
- The SPD **shall** be listed to UL 1449, 4th edition. A test report from a Nationally Recognized Testing Laboratory (NRTL), National Voluntary Laboratory Accreditation Program (NAVLAP), A2LA, or a certified UL client testing data laboratory detailing the procedures used, and the results obtained **shall** be made available to Motorola Solutions for approval.
- The SPD **shall** be a permanently connected, one-port or parallel configuration.
- The suppression components **shall** be voltage limiting type. Voltage switching components **shall not** be utilized as a suppression element in the SPD.
- The enclosure rating of the SPD **shall** be NEMA 4 or higher (NWSM 30-4106.2014, section 2.5.2.2).
- The environmental parameters of the SPD are as follows:
 - Operating temperature range: -40° C to +65 °C (-40° F to +149° F)

- Storage temperature range: -40°C to $+65^{\circ}\text{C}$ (-40°F to $+149^{\circ}\text{F}$)
- Operating humidity range: 0-95%, non-condensing
- Altitude range: -152.4 m to 4572 m (-500 ft to +15,000 ft)
- Electrical connection to the SPD **shall** be made using a 16 mm^2 csa (#6 AWG) or larger conductor. Per NFPA 70-2017, Article 110, the conductor size **shall** match the breaker size.
- Each SPD **shall** have indicator lamps on or visible from the front of the device showing that power is applied and that the protection integrity has not been compromised.
- The SPD **shall** include the capability for remote monitoring, such as form “C” dry contacts or Simple Network Management Protocol (SNMP) traps. The device **shall** indicate when there is an input power failure or the integrity of any module has been compromised.
 - A device using SNMP traps will indicate power failure by a loss of communications in the SNMP managing device.
 - Form C contacts **shall** be isolated from the AC power circuitry to safeguard the alarm circuit or reporting device should there be a catastrophic event.
 - Connection to the remote monitoring contacts of the SPD **shall** utilize 0.34 mm^2 (#22 AWG) or larger conductors.
- Except in Protected Multiple Earth (PME) systems, suppression modules **shall not** be connected between any phase conductor or neutral conductor and the equipment grounding conductor or ground (L-G, Common Mode Neutral to Ground).
- The SPD module(s) **shall** consist of Metal Oxide Varistor (MOV) module(s). See “Impulse Surge Durability Test Requirements” on page 7-57 for Motorola Solutions certification requirements.
- The minimum pulse life or durability requirements and the voltage protection level **shall** be as specified in Table 7-2 for a Type 2B device.
- SPD **shall** be properly selected based on the operating voltage and number of phases of the circuits to be protected.
- Each module or sub assembly **shall** be modular in design to allow for easy field replacement.
- The SPD **shall** use integral overcurrent protective devices and **shall** have a minimum short circuit current rating SCCR of 25,000 amperes, as defined by UL 1449, 4th edition, section 44.2.
- The manufacturer declared Nominal Discharge Current value (I_n) for Motorola Type 2A and Type 2B **shall** be 20kA, (L-L) (L-N), UL 1449 4th edition 40.7.1, using $8/20\mu\text{s}$ waveshape, per IEEE C62.45-2002.
 - **Exception:** A generator that can be calibrated to produce $8/20\mu\text{s}$ waveform with the Equipment Under Test (EUT) in the circuit is considered acceptable.
- The SPD **shall** have a Voltage Protection Rating (VPR) (at the nominal discharge current of 10,000 amperes) not to exceed 900 V_p (L-N), 1200 V_p (L-L) at $6\text{kV}/10\text{kA}$ $8/20\mu\text{s}$, per IEEE C62.45-2002.
 - Voltage Protection Rating (VPR) varies according to Nominal System Voltage (NSV), see Table 7-2 for NSV greater than 120V.
- Test points are measured using specified conductor size at a distance of 150 mm (6 in.) outside of the enclosure.
- Type 2B Maximum Continuous Operating Voltage (MCOV) **shall not** exceed 138V (L-N) for 120V_{rms} service voltage. See Table 7-2 for higher voltage services.



Figure 7-8 Example of Type 2B SPD Installed at Building Entry

7.5.2.3 Type 3 Point of Use Surge Protective Device

Individual equipment Surge Protective Devices (SPD) are available in many varieties. These may be wire-in receptacle outlet replacement types, plug-in adapters, receptacle outlet panels, Power Distribution Units (PDU) or power strips. General requirements are as follows:

- The device **shall** be UL listed for the stated application or conform to the international CE certification mark.

- For Motorola Solutions certification, surge circuits or blocks **shall** include a test report from a Nationally Recognized Testing Laboratory (NRTL), National Voluntary Laboratory Accreditation Program (NAVLAB), A2LA, or a certified UL client testing data laboratory, which confirms the surge components meet UL 1449 4th edition Type 3 or Type 4 specifications.
- Common Mode (L-G, N-G) circuit protection **shall not** be permitted, except in a Protected Multiple Earth (PME) system.
- Individual devices with the plug manufactured as a combined part of the device **shall** be designed to be plugged into a simplex receptacle outlet and **shall** incorporate a single receptacle outlet for the load connection.
- Individual plug-in units with duplex receptacle outlets or power strips are acceptable provided the circuit does not service critical loads which cannot operate independently.
- Multi-receptacle outlet strip devices **shall** incorporate an independent ground point on the exterior of the device. This attachment point or stud **shall** be suitable for attachment of a lug sized for a 16 mm² csa (#6 AWG) conductor.
- Multi-receptacle device housings **shall** be metallic and **shall** have mounting ears, tabs or brackets suitable for rack or cabinet mounting.
- Each device **shall** have an indicator lamp visible from the front of the device showing that the module has power applied and that the protection integrity has not been compromised. Alarm relay contacts or Simple Network Management Protocol (SNMP) traps to remotely report device status may be offered but are not required.
- The minimum pulse life or durability requirements and the voltage protection level is specified in Table 7-2 for the respective Maximum Continuous Operating Voltage (MCOV) listed.
- Type 3 SPDs for critical loads are recommended where the critical loads are located between 9.144 m (30 ft) and 15.2 m (50 ft) from the neutral-ground bond.
- Type 3 SPDs for critical loads are required for geographic locations of high-lightning activity, where the critical loads are located greater than 9.144 m (30 ft) from the neutral-ground bond. High-lightning areas are defined as areas with lightning flash density greater than two (2) flashes/km²/year. See “Lightning Activity and Exposure” on page 4-3 for more information.
- Type 3 SPDs for critical loads are required for all geographic locations where the critical loads are located greater than 15.2m (50 ft) from the neutral-ground bond.
- A Type 3 SPD is recommended for all loads located greater than 15.2 m (50 ft) from the neutral-ground bond.



Figure 7-9 Example of Rack Mounted Type 3 SPD



NOTE

The system engineer, system manager and/or the system owner **shall** define the critical load(s). A critical load is generally considered any load that impacts system availability and the end user's ability to effectively communicate on the system.



Figure 7-10 Example of Rack Mounted Power Distribution Unit with Type 3 SPD



IMPORTANT

UL Type 3 Surge Protective Devices (SPD) shall be marked on the unit, a marking tag, or an instruction sheet packed with the unit with the following: “CAUTION – Do not install this device within 9.144 m (30 ft) of the AC Neutral-Ground bond” (UL1449, 4th edition, section 80.3).

EXCEPTION: UL Type 3 SPDs that have been subjected to the Nominal Discharge Current Testing need not provide this marking. In order to be installed less than 10 meters of conductor length from the electrical service panel, the UL Type 3 device must have a Nominal Discharge Current rating clearly marked on the product or packaging.

7.5.3 SPD Specifications for Safety and Performance



NOTE

Table 7-2 reflects the UL 1449 4th edition IEEE/ANSI approval dates, including 31-October-2014 and 20-February-2015.

Table 7-2 SPD SPECIFICATIONS

Type	Service Configuration	MCOV	Required Measured Testing (see “AC Power Line SPD Test Certification Requirements” on page 7-56)				
			Safety	Performance			
			Voltage Protection Rating (VPR) UL 1449 4th edition 6 kV/3 kA Type 2A/2B 6kV/200A Type 3	SCCR 25KAic to 65KAic	Duty Cycle Test, IEEE C62.41 Type 2A/2B: 6kV/3kA 6kV/10kA Type 3: 6kV/200A	Nominal Discharge Current (I _n)	Nominal Service Voltage
Type 2A (see “Type 2A (SAD/MOV) Surge Protective Device” on page 7-12)							
Suitable for high lightning exposure sites: Main service load side of the disconnect and subpanels. Suitable for protecting sensitive loads, power supplies and electronics.	120/240 V 1φ	138 V	No more than 700	N/A	Required	SVR Recorded (see Note at end of table)	120
	120/208 V 3φ	138 V	No more than 700				120
	277/480 V 3φ	325 V	No more than 1500				277
	230/380 3φ	276 V	N/A				230
Type 2B (see “Type 2B (MOV) Surge Protective Device” on page 7-14)							
Suitable for high lightning exposure Main service load side of the disconnect or subpanels Suitable for transfer switch and rectifier protection.	120/240 1φ	138 V	No more than 1000	N/A	Required	SVR Recorded (see Note at end of table)	120
	120/208 3φ	138 V	No more than 1000				120
	277/480 V 3φ	325 V	No more than 1500				277
	230/380 3φ	276 V	N/A				230
Type 3 (see “Type 3 Point of Use Surge Protective Device” on page 7-16)							
Branch circuit protection device.	120 V	138 V	No more than 500	Required	N/A	N/A	N/A
Suitable for point of use, secondary to Type 2A for high lightning zones and where the Type 2A is greater than 9.144m (30 ft) from a high priority load.	230-240V	276 V	No more than 800	N/A	N/A		
NOTE: Nominal Surge Current Value (I _n) is a single 10 kA impulse. This single impulse shall be applied at the SPDs and the Surge Voltage Rating (SVR) measured and recorded.							

7.6 AC Power SPD Requirements

All Surge Protective Devices (SPD) **shall** be installed per the manufacturer's installation instructions and in accordance with all applicable codes. Type 2A (SAD/MOV) and Type 2B (MOV) devices **shall** be securely attached to the mounting surface and **shall not** depend on the interconnecting raceway for support.

7.6.1 Location

When selecting the location, consideration must be given to conductor routing, length and required number of bends in each conductor. Type 2A and 2B panelboard SPDs **shall** be installed as close as practicable to the associated main disconnect or panelboard to be protected. See sections "Type 2A (SAD/MOV) Surge Protective Device" on page 7-12" and "Type 2B (MOV) Surge Protective Device" on page 7-14 for device specifications and installation requirements.

Type 3 SPD **shall** be installed as close as practicable to the load. See "Type 3 Point of Use Surge Protective Device" on page 7-16 for Type 3 device specifications and installation requirements.



NOTE

To minimize the impedance path and to improve SPD performance, Type 2A and Type 2B SPD service conductors **shall** be kept as short as practicable with minimal bends. Where practicable, the length of service conductors between the disconnect and the SPD should be less than 1.524 m (5 ft).

7.6.2 Interconnecting Raceway or Conduit

The raceway or conduit between the panelboard (or disconnecting means) and the SPD **shall** be sized for the size and number of conductors to be routed through it. A non metallic conduit (such as PVC) or raceway is recommended. The length **shall** be as short as practicable. This raceway **shall** be routed as directly as practicable between the SPD, the disconnecting means (if a separate enclosure is used) and the associated panelboard. The raceway or conduit **shall not** be used as a support for the device.

7.6.3 Circuit Breaker or Disconnecting Means

The SPD **shall** be wired through a 60-Ampere (or larger) circuit breaker (see manufacturer installation instructions). The circuit breaker **shall** meet the requirements of NFPA 70-2017, Article 110.9, or according to local jurisdictional codes. See Figure 7-11 for an example.



Figure 7-11 Example of SPD Exterior Disconnect

7.6.4 Conductor Size, Length and Routing

Conductor size, total circuit length and routing are critical to proper SPD performance. The conductor **shall** be of the minimum size recommended by the manufacturer, however, **shall not** be smaller than 16 mm² csa (#6 AWG). Larger conductor sizes are most desirable. Where practicable, a maximum conductor length **shall not** exceed 152.4 cm (5 ft). The conductors **shall** be routed together and **shall** be free of sharp bends or angles of less than 90 degrees. See Figure 7-12 for an example of SPD conductor length and routing between the SPD and Automatic Transfer Switch (Type 2B) and between the AC load center and SPD (Type 2A).

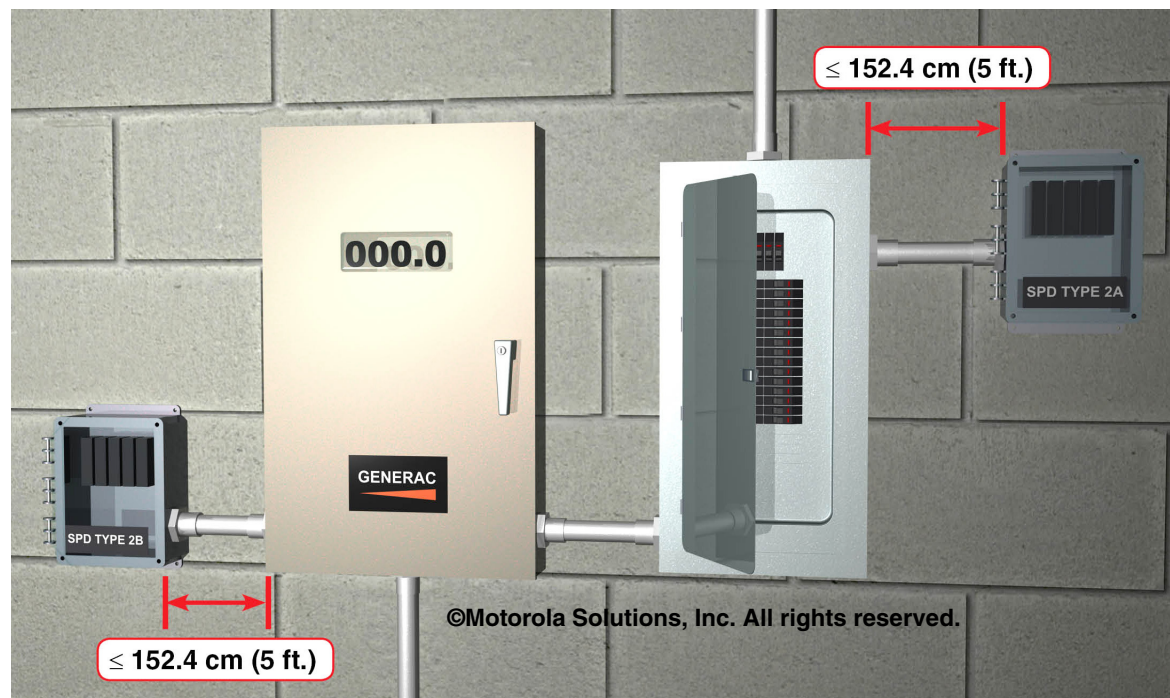

Figure 7-12 Example of SPD Conductor Length

7.6.5 AC Power Performance Evaluation

Surge Protective Devices (SPD) **shall** be evaluated using the specific criteria outlined in Table 7-2 and “AC Power Line SPD Test Certification Requirements” on page 7-56, in addition to UL 1449 4th edition listing for Type 2 and Type 3 devices. Testing certification results **shall** be provided to Motorola Solutions. Devices that do not meet this minimum criteria **shall not** be furnished, installed, or recommended for Motorola Solutions installations.

7.7 Telephony, Data, Signaling, Alarm and Network Circuit Protection

The following cables/conductors entering a communications site, shelter, room, equipment area or pole/pad mounted cabinet **shall** be protected with suitable Surge Protective Devices (SPD) (see ATIS-0600334.2013, section 11):

- Telephony (NFPA 70-2017, Article 800)
- Alarm (NFPA 70-2017, Article 760)
- Broadband and Fiber Optic Cabling (ATIS-0600036.2016)
- Broadband (IEEE 802.16)
- Broadband (NFPA 70-2017, Article 830)
- Broadband and other miscellaneous communications circuits (Telcordia 1089-CORE)

- Issue 4 or higher, Class 3 and 4, IEC 60950, UL 497)
- Network (NFPA 70-2017, Article 830)
- Signaling (NFPA 70-2017, Article 725)

Surge protectors **shall** be installed on all conductive communications and signaling circuits, in use or designated for future use, within 61 cm (24 in.) of entering any building or equipment enclosure. SPDs **shall** be bonded to earth according to manufacturer specification and **shall** meet the minimum specified design and application criteria in accordance with local codes and regulations.

Surge Protective Devices (SPD) used for protecting critical communications links **shall not** interrupt the circuit except in the event the SPD self-sacrifices or disconnects the load due to electrical fault. Qualified SPDs **shall** be listed to UL 497A or demonstrate compliance with ATIS-0600036.2016, Telcordia 1089-Core, Issue 4 or higher, Level 2 or 3 Lightning/Surge protection or both (see Table 7-3).



CAUTION

Careful consideration **shall** be paid to grounding and bonding of the SPD.



IMPORTANT

Cables/conductors designated for future expansion/use shall be surge protected or bonded to earth.



NOTE

In this manual, high-lightning areas are areas with lightning flash density greater than two (2) flashes/km²/year. See “Lightning Activity and Exposure” on page 4-3.



IMPORTANT

In order to prevent transients from coupling to the protected side of a cable, the protected and unprotected sides of the cables must be kept physically isolated from one another as much as practicable and by at least 100 mm (4 in.). The suggested best practice it to run the unprotected side down one side of the rack and the protected side down the other side. See Figure 7-13 for an example.

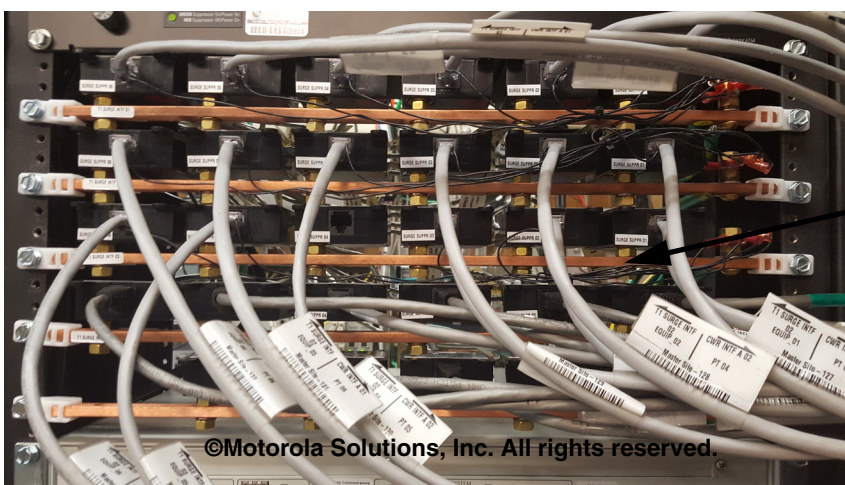

Rack Bonding Bar

©Motorola Solutions, Inc. All rights reserved.

Figure 7-13 Protected Side and Unprotected Side of Cable Maintain Physical Separation

7.7.1 Cable Separation

Where telephone, network or signaling cables are in close proximity with motors, generators, induction heaters, industrial machinery or RF transmission cables, it is necessary to maintain separation to reduce noise and/or transient voltage (surge) coupling between various conductors. See “Network Cable Installation and Routing” on page 9-44 for cable separation requirements and recommendations.

7.7.2 Bonding and Grounding (Earthing) of Telephone, Data, Signaling, Alarm and Network Circuit Surge Protective Devices

Surge protective devices for telephone, data, signaling, alarm and network circuits **shall** be grounded/bonded according to “Surge Protective Devices” on page 5-117 and applicable subsections.

7.7.3 Links Provided by the Telephone (Wireline) Service Provider



NOTE

The United States Federal Communications Commission (FCC) directive, Part 68 (47 C.F.R), requires licensed commercial wireline service providers of high-speed communications circuits to isolate Terminal Equipment (TE), including DS-1, DSL media converters, operated within a Public Switched Telephone Network (PSTN) from Customer edge Premises Equipment (CePE) within 30.48 cm (12 in.) of the point where the cable enters the subscriber's facility. Known as the “12 Inch Rule”, carriers, including cable television providers **shall** “safely” terminate exposed overhead and buried cables in accordance with FCC rules, by grounding shields and removing transmission voltages necessary for signal boost and insulation protection.

The Service Termination Edge (Network Interface Device (NID)) (see Figure 7-14) is the point where the carrier network ends and the customer premises begins. For traditional telephony (T1/E1), cable (DSL/ADSL) and fiber optic backbones, the transition from a powered network control plane to the customer premises management plane makes bidirectional communication possible through layered protocol necessary for LAN communications (for example, Telnet, SNMP, SSH or XML) (see Figure 7-15). Where necessary, a service provider demarcation point extension may be used to boost the network control transmission path beyond the traditional demarcation (see Note in this section) to routers or Smart Jacks located at strategic points within larger commercial structures (for example, telco closet).

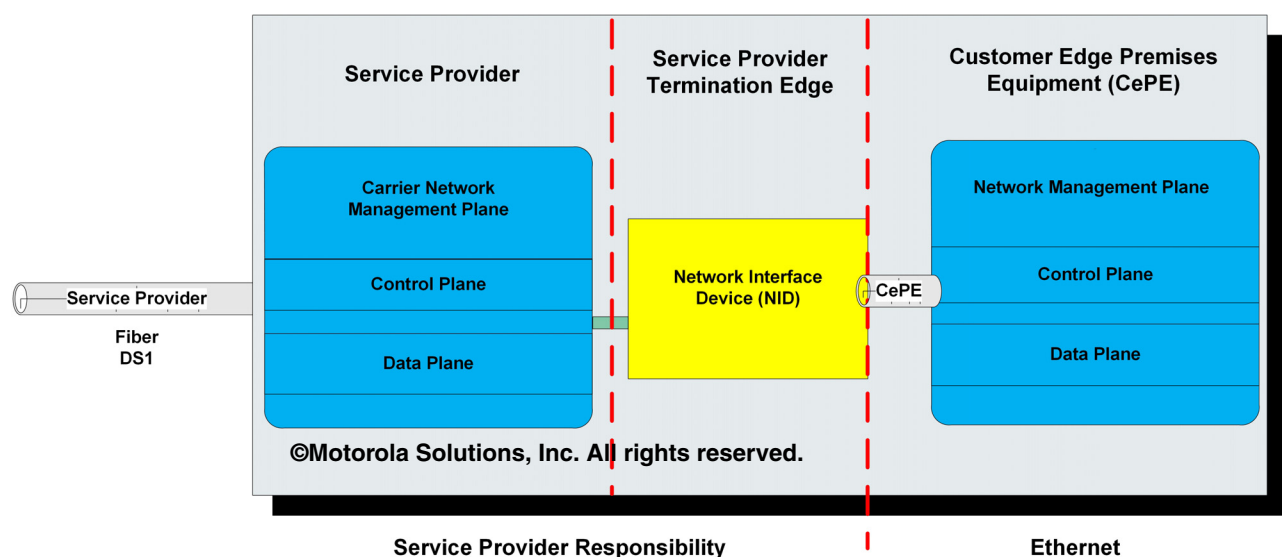

Figure 7-14 Example of Telco Demarcation (Network Interface Device) to Customer Edge Premises Equipment



Figure 7-15 Example of Service Provider Demarcation (Network Interface Device)



NOTE

Installation of Primary SPDs is the responsibility of the service provider.

7.7.3.1 Analog Site Links Provided by the Telephone Service Provider

Many legacy systems require analog site links (such as tone-controlled base station). Analog sites links provided by the telephone service provider (or other service provider) **shall** contain the following surge protection:

- Primary Surge Protective Device (SPD) installed at the telephone service provider demarcation point as required by NFPA 70-2017, Article 800 (service provider supplied). In high-lightning areas, it is recommended to also install a secondary SPD at the service provider demarcation point (on the customer side of the primary SPD).
- Bonding of the telephone service provider ground according to “Common Grounding” on page 4-6.
- Secondary SPD installed as close as practicable to the protected equipment. The secondary device **shall** meet the following requirements:
 - The SPD **shall** be designed for the purpose.
 - The SPD **shall** be of solid state construction.
 - The SPD should be listed to UL 497 or **shall** be qualified GR 1089 (see Table 7-3).
 - The SPD **shall** protect all cable conductors or short unused conductors to earth.
 - The SPD **shall** be bonded to earth according to “Surge Protective Devices” on page 5-117.
- Refer to “Optical Fiber Links” on page 7-26 if the circuit is provided using optical fiber.

7.7.3.2 Digital Site Links Provided by the Telephone Service Provider

Most new digital based systems (for example, P25 and TETRA) require digital site links. The digital site link may be ATM, DSL, Ethernet, T1, fractional T1 or other Internet-type connection. Digital site links provided by the telephone service provider (or other service provider) **shall** contain the following surge protection:

- Primary Surge Protective Device (SPD) installed at the telephone service provider demarcation point as required by NFPA 70-2017, Article 800 (service provider supplied). In high-lightning areas, it is recommended to also install a secondary SPD at the service provider demarcation point (on the customer side of the primary SPD).
- Bonding of the telephone service provider ground according to “Common Grounding” on page 4-6.
- Secondary SPD installed as close as practicable to the protected equipment (for example, Site Access Router or Network Monitoring Firewall). The secondary device **shall** meet the following requirements:
 - The SPD **shall** be designed for digital links (for example, data speed and voltage levels).
 - The SPD **shall** be of solid state construction.
 - The SPD should be listed to UL 497 or **shall** be qualified GR 1089 (see Table 7-3).
 - The SPD **shall** protect all cable conductors or short unused conductors to earth.
 - The SPD **shall** be bonded to earth according to “Surge Protective Devices” on page 5-117.
- Refer to “Optical Fiber Links” on page 7-26 if the circuit is provided using optical fiber.



Figure 7-16 Secondary Surge Protective Devices Installed Near Protected Equipment



IMPORTANT

Ensure the SPD is rated for the data speed of the circuit. The SPD shall not negatively impact data rate.



IMPORTANT

Primary surge protection provided by the telephone service provider does not negate the need for secondary surge protective devices (see “Secondary Telephone Protection” on page 7-29).

7.7.3.3 Optical Fiber Links

Many site links are provided by an electrically isolated source, such as optical fiber. An intrinsic benefit of optical fiber links is that they offer excellent isolation from lightning induced ground potential rise, line-induced lightning strikes, RF and electrical noise coupling.

Primary surge protection is not required on these types of links because of the electrical isolation from outside electrical disturbances. The optical fiber cable metallic shield, jacket or drain (if applicable) **shall** be bonded/grounded according to “External Ground Bus Bar” on page 4-43 and “Telecommunication Cable Metallic Shields” on page 5-122 (NWSM 30-4106.2014, section 2.6.9).

Secondary surge protection **shall** be provided on the equipment end of copper circuit conductors originating at an optical fiber Network Interface Unit (NIU) as follows:

- A secondary Surge Protective Device (SPD) **shall** be installed if the cable between the Network Interface Device (NID) and customer equipment (CePE) length exceeds 9.144 m (30 ft). The secondary device **shall** meet the following requirements:
 - The SPD **shall** be designed for link type (for example, data speed and voltage levels).
 - The SPD **shall** be of solid state construction.
 - The SPD should be listed to UL 497 or **shall** be qualified GR 1089 (see Table 7-3).
 - The SPD **shall** protect all cable conductors or short unused conductors to earth.
 - The SPD **shall** be bonded to earth according to “Surge Protective Devices” on page 5-117.
- In high-lightning geographic areas, a secondary surge protective device **shall** be installed regardless of the cable length.



IMPORTANT

Ensure the SPD is rated for the data speed of the circuit. The SPD shall not negatively impact data rate.



Figure 7-17 Typical Carrier Optical Network Terminal

7.7.3.3.1 Optical Fiber Links Terminated Outside the Radio Shelter

Where the fiber demarcation is located outside of a structure or cabinet (such as at an H-frame or telco pedestal), the following **shall** apply:

- The cable between the Network Interface Device (NID) and radio shelter/cabinet (CePE) **shall** be outdoor rated Shielded Twisted Pair (STP).
- The cable shield **shall** be bonded according to “External Ground Bus Bar” on page 4-43 and “Telecommunication Cable Metallic Shields” on page 5-122 or be bonded to the Primary Bonding Bar (PBB) or entry point Secondary Bonding Bar (SBB).
- Within 61 cm (24 in.) of entering the radio shelter/cabinet, the cable **shall** be protected with a device meeting the specifications of a secondary Surge Protective Device (SPD) (see Table 7-3). The secondary device **shall** meet the following requirements:
 - The SPD **shall** be designed for link type (for example, data speed and voltage levels).
 - The SPD **shall** be of solid state construction.
 - The SPD **shall** be listed to UL 497 or be qualified GR 1089 (see Table 7-3).
 - The SPD **shall** protect all cable conductors or short unused conductors to earth.
 - The SPD **shall** be bonded to earth according to “Surge Protective Devices” on page 5-117.
- An additional secondary SPD **shall** be installed as close as practicable to the customer equipment (CePE) if the cable length between the customer equipment and entry point SPD exceeds 9.144 m (30 ft).
 - The SPD **shall** be designed for link type (for example, data speed and voltage levels).
 - The SPD **shall** be of solid state construction.
 - The SPD should be listed to UL 497 or **shall** be qualified GR 1089 (see Table 7-3).
 - The SPD **shall** protect all cable conductors or short unused conductors to earth.
 - The SPD **shall** be bonded to earth according to “Surge Protective Devices” on page 5-117.



Figure 7-18 Example of Shielded Cable Bonding Kit



IMPORTANT

Ensure the SPD is rated for the data speed of the circuit. The SPD shall not negatively impact data rate.

7.7.4 Microwave Links

Many site links are provided by an electrically isolated source, such as microwave. Primary surge protection is not required on these types of links because of the electrical isolation from outside electrical disturbances. The microwave RF feedline **shall** be bonded/grounded according to “Grounding and Bonding of RF Transmission Lines and Other Communications Cables” on page 4-97. The microwave equipment and rack **shall** be bonded according to Chapter 5, “Internal Bonding and Grounding (Earthing)”.

Secondary surge protection **shall** be provided on the equipment end of copper circuit conductors originating at the microwave as follows:

- A secondary Surge Protective Device (SPD) **shall** be installed as close as practicable to the customer equipment (for example, channel bank or router) if the cable between the microwave and the customer equipment exceeds 9.144 m (30 ft). In high-lightning geographic areas, a secondary surge protective device **shall** be installed regardless of the cable length.
- The secondary SPD **shall** meet the following requirements:
 - The SPD **shall** be designed for link type (for example, data speed and voltage levels).
 - The SPD **shall** be of solid state construction.
 - The SPD should be listed to UL 497 or **shall** be qualified GR 1089 (see Table 7-3).
 - The SPD **shall** protect all cable conductors or short unused conductors to earth.
 - The SPD **shall** be bonded to earth according to “Surge Protective Devices” on page 5-117.
- A secondary SPD should be installed as close as practicable to the microwave multiplexer equipment if the cable between the microwave multiplexer and the customer equipment exceeds 9.144 m (30 ft). This is especially important in high-lightning geographic areas.



IMPORTANT

Ensure the SPD is rated for the data speed of the circuit. The SPD shall not negatively impact data rate.

7.7.5 Inter-building Cabling Links

Site links may originate in one building via telephone service provider, fiber, microwave and so on and be distributed to another building to the communications room/shelter via copper conductors (for example, STP). The site links in the originating building **shall** be surge protected as described in the section for each link type. The inter-building cabling **shall** use Shielded Twisted Pair (STP) cables or a type of optical fiber link.



NOTE

Optical fiber based inter-building links are preferred because of their intrinsic immunity to transient surges and ground potential rise (see IEEE 1692-2011).

The following are the inter-building cabling surge protection and installation requirements:

- Within 61 cm (24 in.) of building entry, inter-building cabling **shall** terminate to a demarcation point.
- At each demarcation point (both buildings), the cable **shall** be protected with a device meeting the specifications of a secondary Surge Protective Device (SPD) (see Table 7-3).
- The secondary SPD **shall** meet the following requirements:
 - The SPD **shall** be designed for link type (for example, data speed and voltage levels).
 - The SPD **shall** be of solid state construction.
 - The SPD **shall** be listed to UL 497 or qualified GR 1089 (see Table 7-3).
 - The SPD **shall** protect all cable conductors or short unused conductors to earth.
 - The SPD **shall** be bonded to earth according to “Surge Protective Devices” on page 5-117.
- A secondary SPD **shall** be installed as close as practicable to the customer equipment (for example, channel bank or router) if the cable between the radio building/shelter demarcation point and the customer equipment exceeds 9.144 m (30 ft). In high-lightning geographic areas, a secondary surge protective device **shall** be installed regardless of the cable length.
 - The SPD **shall** be designed for link type (for example, data speed and voltage levels).

- The SPD **shall** be of solid state construction.
- The SPD should be listed to UL 497 or **shall** be qualified GR 1089 (see Table 7-3).
- The SPD **shall** protect all cable conductors or short unused conductors to earth.
- The SPD **shall** be bonded to earth according to “Surge Protective Devices” on page 5-117.
- A secondary SPD should be installed as close as practicable to the link source equipment (for example, microwave multiplexer or fiber NIU) if the cable between the link source building demarcation point and the link source equipment exceeds 9.144 m (30 ft). This is especially important in high-lightning geographic areas.
- Refer to “Optical Fiber Links” on page 7-26 if the inter-building link is provided using optical fiber.



IMPORTANT

Ensure the SPD is rated for the data speed of the circuit. The SPD shall not negatively impact data rate.



IMPORTANT

If the buildings do not share a common grounding electrode system, the shield on the cable at one of the buildings shall be isolated as described in “Telecommunication Cable Metallic Shields” on page 5-122. Also see Caution in “Network Cable Installation and Routing” on page 9-44.

7.7.6 Telephone Exchange Protection

Surge protection of telephone exchange circuits pursuant with NFPA 70-2017, Article 280 **shall** be the responsibility of the telephone service provider. Fault limiting SPDs are not suitable for protecting critical communications links. Primary fault limiting SPDs, fuses, GAP or crowbar, **shall** be listed to UL 497 as fault limiting primary protection.



IMPORTANT

Primary surge protection provided by the telephone service provider does not negate the need for secondary surge protective devices (see “Secondary Telephone Protection” on page 7-29).

7.7.6.1 Secondary Telephone Protection

Secondary SPDs are recommended for telephone line and PBX circuits.

Devices that include a solid state voltage limiting component with a required fault limiting component are best suited for secondary telephone line protection. Devices should be listed to UL 497A or demonstrate compliance with GR 1089-Core issue 4, Port 1 and Port 2, 3kA 8/20 μ s.

7.7.7 Computer Network Protection (Ethernet)

Small computer networks (in the same room or area) are not typically exposed to transients. As the computer network extends to other rooms and/or floors within the building, the exposure to transients increases. This exposure is increased if a communications tower is co-located with the building. Computer network cabling **shall** maintain the greatest physical separation from the tower as practicable, especially where the cable is installed parallel to the tower (vertical).

- Intra-room (within the same room) and/or intra-rack computer network cabling does not typically require surge protective devices.
- Computer networking cabling extending to another room or area (inter-room), should have an appropriate secondary Surge Protective Device (SPD) installed at each end if the cable exceeds 30.5 m (100 ft).
- The secondary SPD **shall** meet the following requirements:
 - The SPD **shall** be designed for link type (for example, data speed and voltage levels).

- The SPD **shall** be of solid state construction.
- The SPD should be listed to UL 497 or **shall** be qualified GR 1089 (see Table 7-3).
- The SPD **shall** protect all cable conductors or short unused conductors to earth.
- The SPD **shall** be bonded to earth according to “Surge Protective Devices” on page 5-117.
- Any outside connection to/from the computer network **shall** be surge protected as described in the section for each link type. Such connections may be the following:
 - Remote site link
 - Network monitoring link
- Inter-building computer network cables **shall** be protected as described in “Inter-building Computer Network Protection” on page 7-30. Some examples are as follows:
 - A remote dispatch operator position installed in a different building.
 - A network management terminal installed in a different building.



©Motorola Solutions, Inc. All rights reserved.

Figure 7-19 Example of Ethernet Surge Protective Device



IMPORTANT

SPDs shall not be installed on each end of a twisted pair cable shorter than 3.048 m (10 ft) unless the STP cable exits the communications shelter or building.

7.7.7.1 Inter-building Computer Network Protection

Computer networking cables (STP) are sometimes run from one building to another. A typical application might be from the radio building/shelter to the main building Radio Network System Administrator’s office for the purpose of running a radio network management terminal. Computer networking cabling entering or exiting the communications building/shelter **shall** be surge protected.

The following are the surge protection and installation requirements for inter-building computer network cabling:

- The inter-building computer networking cable **shall** be Shielded Twisted Pair (STP).
- Within 61 cm (24 in.) of building entry (both buildings), inter-building computer network cabling **shall** terminate to an appropriate Surge Protective Device (SPD).
- At each demarcation point (both buildings), the cable **shall** be protected with a device meeting the specifications of a secondary SPD:
 - The SPD **shall** be designed for link type (for example, Ethernet).
 - The SPD **shall** be of solid state construction.

- The SPD **shall** be listed to UL 497 or qualified GR 1089 (see Table 7-3).
- The SPD **shall** protect all cable conductors or short unused conductors to earth.
- The SPD **shall** be bonded to earth according to “Surge Protective Devices” on page 5-117.
- The SPD **shall** accept shielded connectors, making an electrical bond to the connector shields.

7.7.8 Alarm Circuits

Sites commonly have external alarm circuits for monitoring site equipment (for example, generator, gates, motion detectors, and so on). These alarms typically terminate to an M66 or 110 punch block near the Primary Bonding Bar (PBB). These alarm circuits **shall** be surge protected using a secondary Surge Protective Device (SPD) as follows:

- The alarm circuits **shall** terminate to an M66 punch block or similar demarcation point within 61 cm (24 in.) of building entry.
- The alarm circuit entry point **shall** be located as close as practicable to the PBB. This is to help maintain single-point grounding integrity.
- Secondary SPDs **shall** be installed on all alarm circuits (inputs and outputs) entering or exiting the communications site. The secondary device **shall** meet the following requirements:
 - The SPD **shall** be designed for the purpose.
 - The SPD **shall** be of solid state construction.
 - The SPD **shall** be listed to UL 497 or qualified GR 1089.
 - The SPD **shall** protect all cable conductors or short unused conductors to earth.
 - The SPD **shall** be bonded to earth according to “Surge Protective Devices” on page 5-117.
- Cable shields (if applicable) **shall** be bonded according to “External Ground Bus Bar” on page 4-43 or be bonded to the Primary Bonding Bar (PBB) or entry point Secondary Bonding Bar (SBB).

Alarm circuits that extend to a security/network monitoring center (or similar) via telephone service provider (or other service provider) links **shall** be protected as described in this chapter for the specific link type.



NOTE

Alarm circuits for internal alarms (for example, door, temperature and so on) do not require surge protection.



IMPORTANT

Unused alarms circuits that enter or exit the building shall be surge protected or shorted to earth at the demarcation point (M66 punch block).

7.7.9 SPD Summary and Performance Evaluation for Telephone, Data, Signaling and Network Circuit Protection

Table 7-3 ALARM, DATA, NETWORK, SIGNALING AND TELEPHONE SPD SUMMARY

Link Type	SPD Location	SPD Type	Listing Requirement	Manual Reference	SPD Performance Qualification
Telco Analog Site Link	At Building Entry	Primary (see Note 1)	UL 497	“Analog Site Links Provided by the Telephone Service Provider” on page 7-24	GR-1089-Core Issue 4, Port 1
	As close to the protected equipment as practicable	Secondary	UL 497 recommended		GR-1089-Core Issue 4, Port 3
Telco Digital Site Link	At Building Entry	Primary (see Note 1)	UL 497	“Digital Site Links Provided by the Telephone Service Provider” on page 7-25	GR-1089-Core Issue 4, Port 1
	As close to the protected equipment as practicable	Secondary	UL 497 recommended		GR-1089-Core Issue 4, Port 3
Optical Fiber	As close to the protected equipment as practicable (see Notes 2 and 3)	Secondary	UL 497 recommended	“Optical Fiber Links” on page 7-26	GR-1089-Core Issue 4, Port 4
Optical Fiber Links Terminated Outside the Radio Shelter (see note 4)	At Building Entry	Secondary	UL 497	“Optical Fiber Links Terminated Outside the Radio Shelter” on page 7-26	GR-1089-Core Issue 4, Port 3
	As close to the protected equipment as practicable	Secondary	UL 497 recommended		
Microwave Links	As close to the protected equipment as practicable (see notes 2 and 3)	Secondary	UL 497 recommended	“Microwave Links” on page 7-27	GR-1089-Core Issue 4, Port 4
	As close to the microwave multiplexer equipment as practicable (see note 5)	Secondary			

Notes:

1. Primary SPD is the responsibility of the service provider.
2. The SPD is required only if the cable between the NID (or microwave) and customer equipment (CePE) is longer than 9.144 m (30 ft).
3. The SPD is required in high-lightning geographic areas, regardless of the cable length.
4. The fiber demarcation point is located outside the building (for example, on an H-frame). Copper conductors (STP) are used to extend the link into the building.
5. This SPD is recommended if the cable between the microwave multiplexer and the customer equipment is longer than 9.144 m (30 ft).
6. The SPD is required only if the cable between the building demarcation point and the customer equipment is longer than 9.144 m (30 ft).
7. The SPD is recommended if the cable between the inter-building cabling demarcation point and the link source is longer than 9.144 m (30 ft).

Table 7-3 ALARM, DATA, NETWORK, SIGNALING AND TELEPHONE SPD SUMMARY (CONTINUED)

Link Type	SPD Location	SPD Type	Listing Requirement	Manual Reference	SPD Performance Qualification
Inter-building Cabling Links	Within 61 cm (24 in.) of building entry (both buildings)	Secondary	UL 497	“Inter-building Cabling Links” on page 7-28	GR-1089-Core Issue 4, Port 3
	As close to the protected customer equipment as practicable (see notes 3 and 6)	Secondary	UL 497 recommended	“Inter-building Cabling Links” on page 7-28	GR-1089-Core Issue 4, Port 4
	As close to the link source equipment as practicable (see note 7)	Secondary	UL 497 recommended		
Secondary Telephone (recommended)	As close to the protected equipment as practicable	Secondary	UL 497 recommended	“Secondary Telephone Protection” on page 7-29	GR-1089-Core Issue 4, Port 3
Computer Network (Ethernet)	Recommended on each end of an inter-room cable if the cable is longer than 30.5 m (100 ft)	Secondary	UL 497 recommended	“Computer Network Protection (Ethernet)” on page 7-29	GR-1089-Core Issue 4, Port 4
Computer Network (Ethernet) Outside Connection	Computer network cabling that extends outside the site shall be protected as described in the following sections: <ul style="list-style-type: none"> • “Digital Site Links Provided by the Telephone Service Provider” on page 7-25 • “Optical Fiber Links” on page 7-26 • “Optical Fiber Links Terminated Outside the Radio Shelter” on page 7-26 • “Microwave Links” on page 7-27 • “Inter-building Cabling Links” on page 7-28 • “Computer Network Protection (Ethernet)” on page 7-29 				Refer to specific requirements for link type.
Inter-building Computer Network	Within 61 cm (24 in.) of building entry (both buildings)	Secondary	UL 497	“Inter-building Computer Network Protection” on page 7-30	GR-1089-Core Issue 4, Port 3

Notes:

1. Primary SPD is the responsibility of the service provider.
2. The SPD is required only if the cable between the NID (or microwave) and customer equipment (CePE) is longer than 9.144 m (30 ft).
3. The SPD is required in high-lightning geographic areas, regardless of the cable length.
4. The fiber demarcation point is located outside the building (for example, on an H-frame). Copper conductors (STP) are used to extend the link into the building.
5. This SPD is recommended if the cable between the microwave multiplexer and the customer equipment is longer than 9.144 m (30 ft).
6. The SPD is required only if the cable between the building demarcation point and the customer equipment is longer than 9.144 m (30 ft).
7. The SPD is recommended if the cable between the inter-building cabling demarcation point and the link source is longer than 9.144 m (30 ft).

Table 7-3 ALARM, DATA, NETWORK, SIGNALING AND TELEPHONE SPD SUMMARY (CONTINUED)

Link Type	SPD Location	SPD Type	Listing Requirement	Manual Reference	SPD Performance Qualification
Alarm Circuits (External)	Within 61 cm (24 in.) of building entry	Secondary	UL 497	“Alarm Circuits” on page 7-31	GR-1089-Core Issue 4, Port 3
Alarm Circuits that Extend Outside the Site	Alarm circuits that extend to an alarm monitor service or device via telephone service provider (or other service provider) or other link shall be protected as described in the section for the type of link.				Refer to specific requirements for link type.
CCTV (STP Cables)	Within 61 cm (24 in.) of building entry	Secondary	Not required	“Closed Circuit Television and Security” on page 7-34	GR-1089-Core Issue 4, Port 3
Broadband Point-to-Point and Multi-point (STP Cables) Power over Ethernet (PoE)	Within 61 cm (24 in.) of building entry	Secondary	Not required	“Broadband Point-to-Point and Multi-point Wireless Links” on page 7-35	GR-1089-Core Issue 4, Port 3
	Within 61 cm (24 in.) of outdoor radio	Secondary	Not required		

Notes:

1. Primary SPD is the responsibility of the service provider.
2. The SPD is required only if the cable between the NID (or microwave) and customer equipment (CePE) is longer than 9.144 m (30 ft).
3. The SPD is required in high-lightning geographic areas, regardless of the cable length.
4. The fiber demarcation point is located outside the building (for example, on an H-frame). Copper conductors (STP) are used to extend the link into the building.
5. This SPD is recommended if the cable between the microwave multiplexer and the customer equipment is longer than 9.144 m (30 ft).
6. The SPD is required only if the cable between the building demarcation point and the customer equipment is longer than 9.144 m (30 ft).
7. The SPD is recommended if the cable between the inter-building cabling demarcation point and the link source is longer than 9.144 m (30 ft).

**NOTE**

When selecting an SPD for signal circuits or low voltage DC power circuits (no more than 62 VDC), the maximum voltage limiting of the SPD **shall** match closely to the operating voltage of circuit to be protected, up to +25%. Use care to qualify that the SPD is a solid state voltage limiting circuit, not a fault limiting circuit, fuse or crow-bar device.

7.8 Closed Circuit Television and Security

Each Closed Circuit Television (CCTV), cable television and security system cable entering a communications facility **shall** be surge protected (see ATIS-0600334.2013, section 11.5). Where an RF cable entry port is available, CCTV and similar cables **shall** enter the facility through the cable entry port. Where an RF entrance panel is not available, cables **shall** enter as close as practicable to the point where the power and telephone conductors enter a facility.

Cable shields **shall** be bonded to the External Ground Bus bar (EGB) as described in “External Ground Bus Bar” on page 4-43 or be bonded to the Primary Bonding Bar (PBB) or entry point Secondary Bonding Bar (SBB). SPDs **shall** be installed within 61 cm (24 in.) of the point where the cable(s) enter the communications facility. The ground terminal of the SPD **shall** be bonded to the internal bonding and grounding system as described in “Surge Protective Devices” on page 5-117.

SPDs **shall** be selected based on the application. Fixed camera systems can be AC or DC powered; Pan Tilt Zoom (PTZ) cameras are typically 24 or 110 V AC powered. Consult with the security provider or the manufacturer before selecting the SPD for this application. It is highly recommended to protect PTZ cameras at both ends of the cable run.

CCTV SPDs **shall** meet the requirements of Table 7-3 for Shielded Twisted Pair (STP) cable and Table 7-4 for coaxial cable.

7.9 Broadband Point-to-Point and Multi-point Wireless Links

Broadband wireless links are a low-cost alternative to microwave links. Broadband wireless links are used for local area networks, security systems and for metering circuits. Backhaul and access point products are available for both licensed and unlicensed frequencies, are relatively inexpensive and easy to install. Failure to protect against surges as directed in this chapter, or use of inferior materials, will reduce network performance and maintainability and subject co-located equipment to potentially catastrophic lightning EME, EMI, RFI or EMP. See Figure 7-20, Figure 7-21 and Figure 7-22 for examples.



Figure 7-20 Example of Surge Protective Device for Power over Ethernet Injector

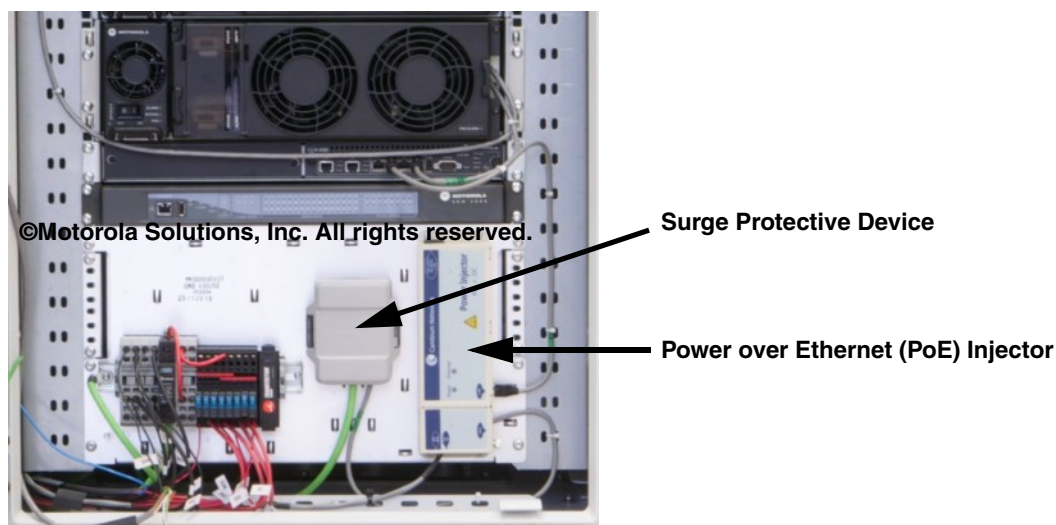

Figure 7-21 Example of Surge Protective Device for Power over Ethernet Injector in Outdoor Cabinet



Figure 7-22 Example of Broadband Wireless Radio

Broadband radio installations **shall** meet the following requirements:

- Installation **shall** meet the manufacturer's requirements as applicable.
- Installation **shall** use shielded CAT 5 or CAT 6 (STP) as applicable (unshielded **shall not** be used). See Figure 7-23.
- Tower mounted devices (including associated external SPDs) **shall** be bonded to the tower according to “Bonding of RF Preamplifiers and Other Active Devices on Tower” on page 4-95 and “Tower-Mounted Devices” on page 4-126.
- Internally installed devices **shall** be bonded and grounded according to Chapter 5, “Internal Bonding and Grounding (Earthing)”.
- Grounding and bonding conductors **shall** meet the minimum bending radius requirements as described in Chapter 4, “External Grounding (Earthing) and Bonding”, and Chapter 5, “Internal Bonding and Grounding (Earthing)”.
- RF and STP cables **shall** meet the minimum bending radius requirements as described in Chapter 9, “Equipment Installation”.
- RF and STP cables **shall** be cut to proper length.
- RF and STP shields **shall** be bonded to the tower as close as practicable to the outdoor wireless radios (see “Grounding and Bonding of RF Transmission Lines and Other Communications Cables” on page 4-97).
- RF and STP shields **shall** be bonded to the tower (if applicable) as described in “Grounding and Bonding of RF Transmission Lines and Other Communications Cables” on page 4-97.
- RF and STP cable shields **shall** be bonded at the point of entry into the communications facility as described in “External Ground Bus Bar” on page 4-43 and “Grounding and Bonding of RF Transmission Lines and Other Communications Cables” on page 4-97.
- STP cables **shall** maintain minimum separation from other cables as described in “Cable Separation” on page 7-23. Maintaining minimum separation between STP cables, current carrying conductors and RF transmission lines is critically important to Ethernet and Power over Ethernet (PoE) performance.
- Surge Protective Devices (SPD) **shall** be installed as follows:
 - Within 61 cm (24 in.) upon entry to the communications facility.
 - As close as practicable to the outdoor radio unit. Within 91.44 cm (3 ft) is recommended.
 - See Figure 7-24 and Figure 7-29.

SPDs protecting wireless broadband radios and switches **shall** meet the minimum specifications of Table 7-3 for STP cables and Table 7-4 for coaxial cables. SPDs on STP **shall** be solid state devices.

SPDs used for outdoor Ethernet or PoE **shall** be solid state circuits housed in outdoor rated enclosures. See Figure 7-24.



IMPORTANT

Unshielded Twisted Pair (UTP) shall not be used for cable runs extending outside the facility.



IMPORTANT

Shielded Twisted Pair (STP) cable used between the cable entry port and broadband radios shall be rated for outdoor use (Figure 7-23 and Figure 7-24), preferably a rigid shield type. Cable shields shall be bonded as close as practicable to the radio and to the cable entry point to buildings and cabinets. See “Grounding and Bonding of RF Transmission Lines and Other Communications Cables” on page 4-97 for more information.



Figure 7-23 Unshielded Twisted Pair (UTP) and Shielded Twisted Pair (STP) Cables



Figure 7-24 SPD Locations for Broadband Wireless Radios

7.10 Satellite and Television Broadband Services

Satellite communications receivers **shall** be installed in accordance with this chapter and NFPA 70-2017 (see Figure 7-25).

Satellite service Customer edge Premises Equipment (CePE) demarcation point **shall** be surge protected as follows:

- Cable shields **shall** be bonded at the point of entry into the communications facility as described in “External Ground Bus Bar” on page 4-43 and “Grounding and Bonding of RF Transmission Lines and Other Communications Cables” on page 4-97. See NFPA 70-2017, Article 830.93(A) and other related articles.
- An SPD **shall** be installed within 61 cm (24 in.) upon entry to the communications facility.



NOTE

An SPD for satellite and television is typically 75 ohms, versus 50 ohms for typical Land Mobile Radio.

- Due to the high exposure to lightning surges, satellite receiver equipment should be connected to a Type 3 AC SPD (see “Type 3 Point of Use Surge Protective Device” on page 7-16). In addition, the satellite receiver chassis should be bonded to the internal bonding and grounding system as described in Chapter 5, “Internal Bonding and Grounding (Earthing)”.

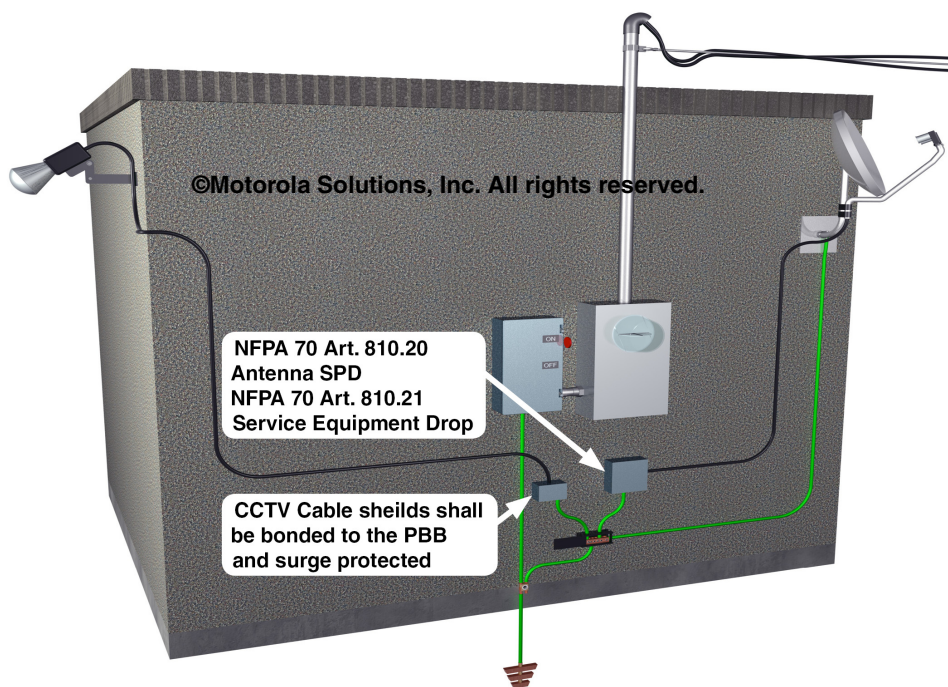

Cable and Satellite Television, Telephony and Broadband cables shall be bonded and surge protected pursuant with this chapter.

Figure 7-25 Bonding and Surge Protection for Cable and Satellite Television, Telephony and Broadband Cables

7.11 RF Surge Protection

Coaxial cables, waveguides and wireless broadband cables typically enter the equipment area through a dedicated building entrance panel (see Figure 7-26). RF coaxial cables **shall** be protected from surges with an RF Surge Protective Device (SPD). All coaxial cables entering the building (or communications room in a larger building) **shall** be surge protected (ATIS-0600313.2013, section 6.4; IEEE 1692-2011, section 8.7; MIL-HDBK-419A; and NFPA 780-2017, section 4.20.6).

The RF SPD shall be installed within 61 cm (24 in.) of entry into the communications facility (or communications room in a larger building). See Figure 7-26, Figure 7-27, Figure 7-28, Figure 7-29, Figure 7-30, Figure 7-31 and Figure 7-32 for examples.



IMPORTANT

RF coaxial and waveguide shields shall be bonded to the tower (if applicable) as described in “Grounding and Bonding of RF Transmission Lines and Other Communications Cables” on page 4-97. RF and waveguide shields shall be bonded at the point of entry into the communications facility as described in “External Ground Bus Bar” on page 4-43 and “Grounding and Bonding of RF Transmission Lines and Other Communications Cables” on page 4-97. See Figure 7-26.

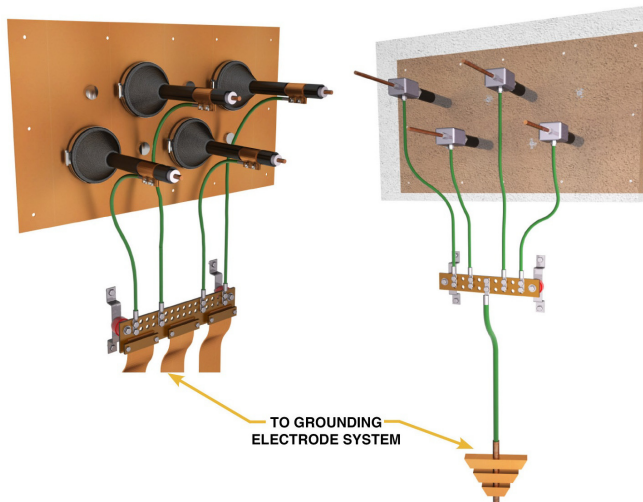

©Motorola Solutions, Inc. All rights reserved.

Figure 7-26 Transmission Line Grounding at Building Entry Point and Surge Protective Device Installation

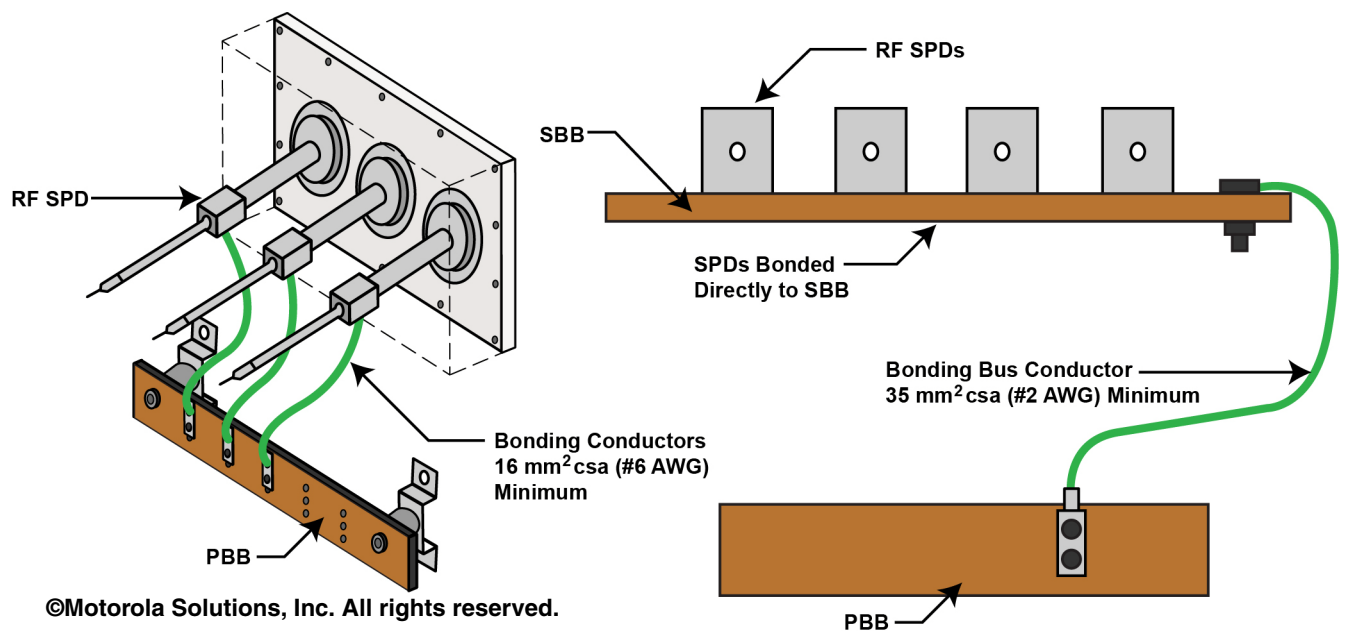

©Motorola Solutions, Inc. All rights reserved.

Figure 7-27 Bonding of RF Surge Protective Devices to Secondary Bonding Bar with Bonding Bus Conductor

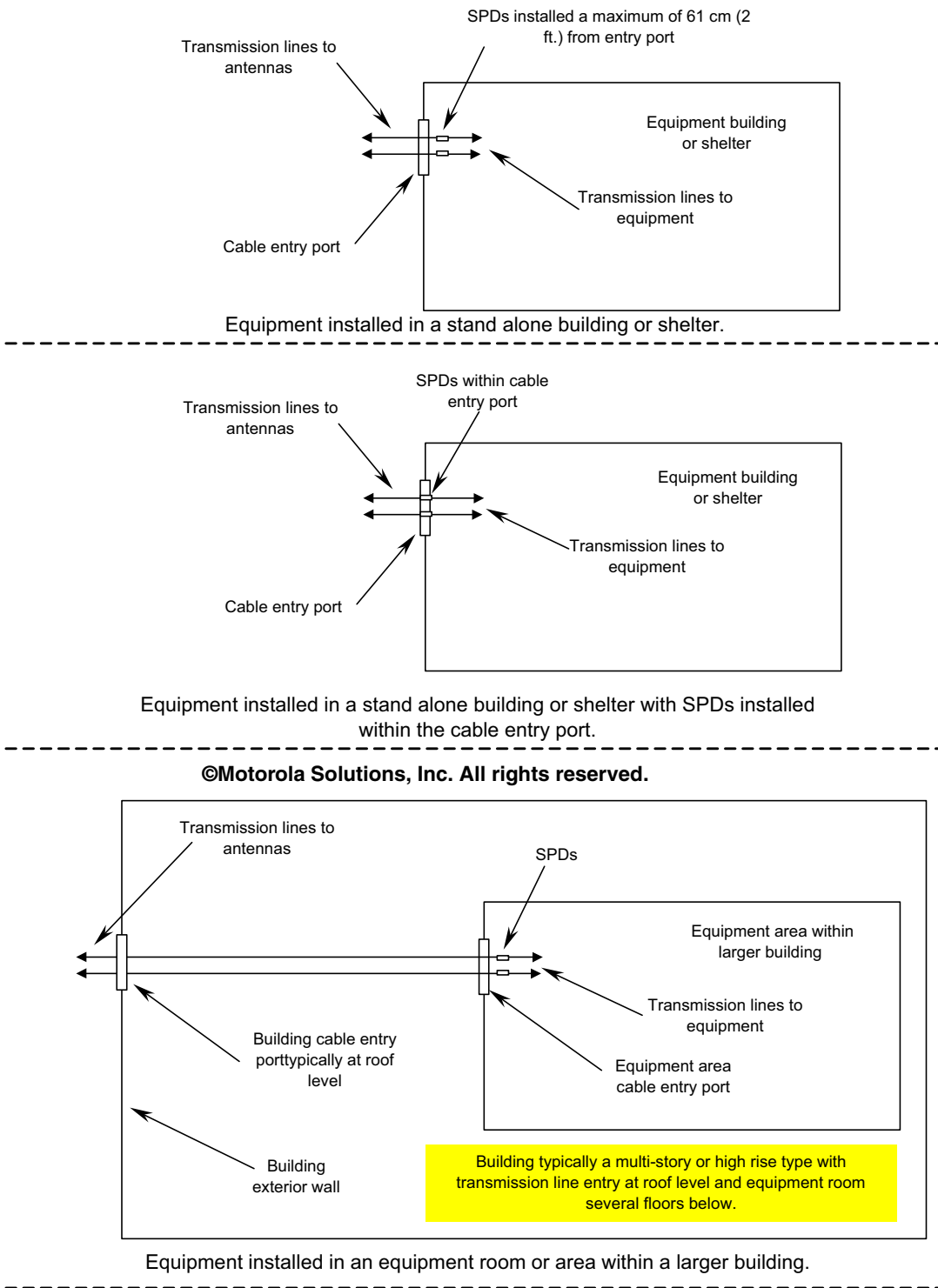

Figure 7-28 Installation Locations for RF Transmission Line Surge Protective Devices

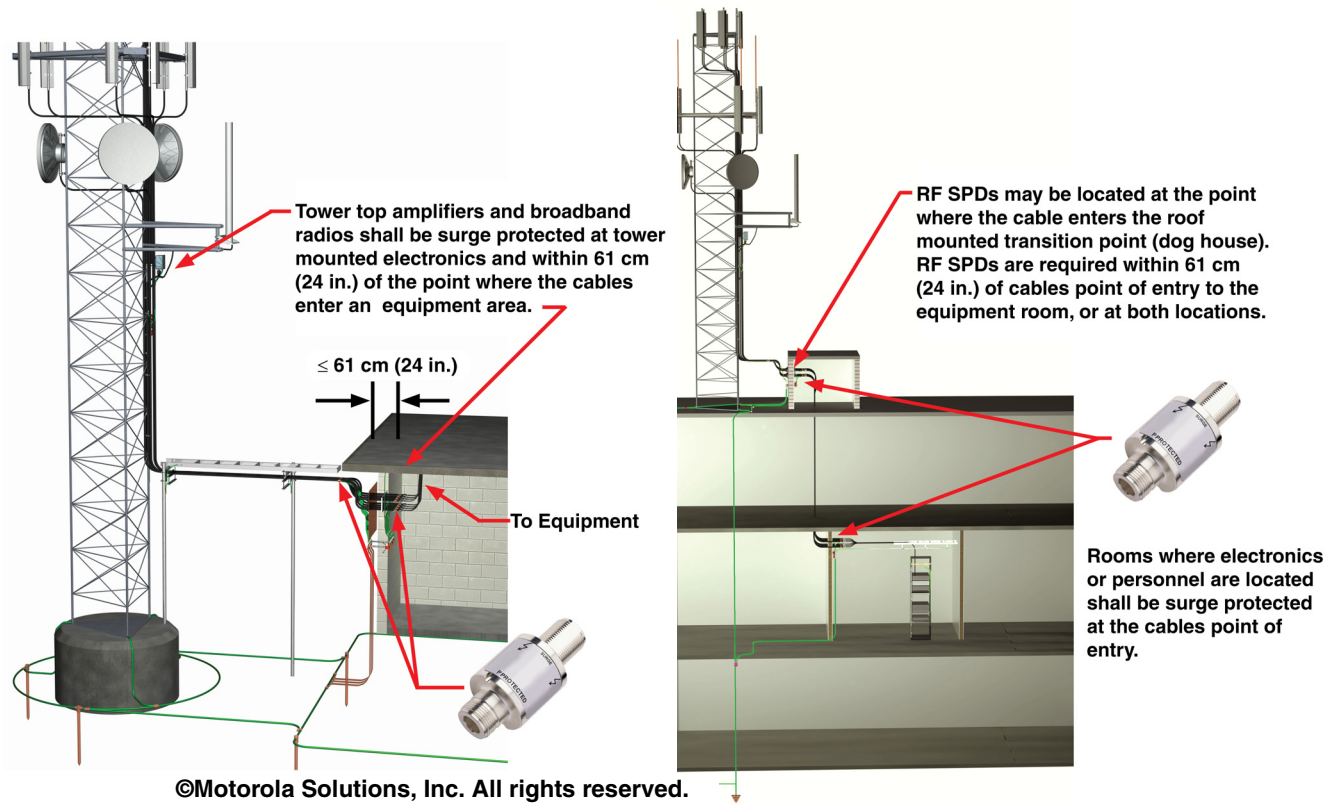

Figure 7-29 Examples of Typical Installation of RF Surge Protective Devices

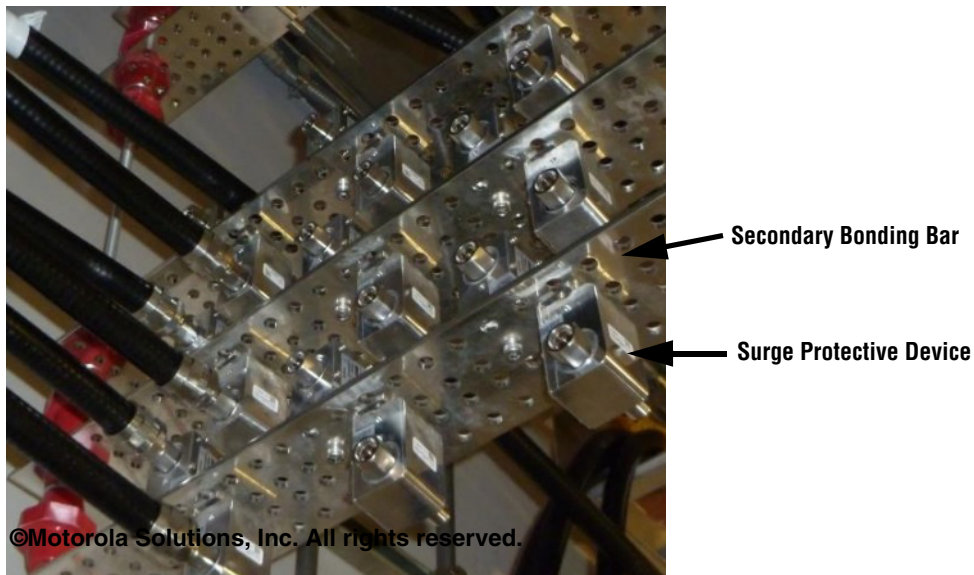

Figure 7-30 Example of RF Surge Protective Device Entry Trapeze Assembly

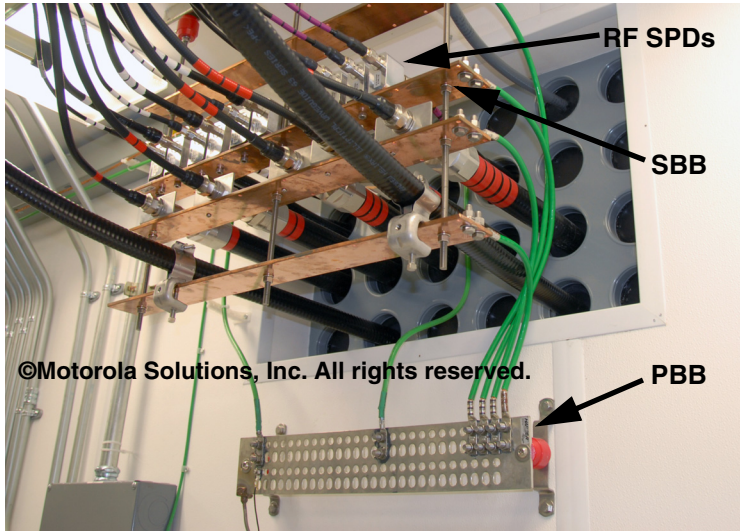

Figure 7-31 Example of RF Surge Protective Devices Bonding and Grounding Directly to Secondary Bonding Bars



NOTE

Skin effect is the tendency of an electrical current to pass through the outer portion or “skin” of a metallic conductor, rather than through the center. The skin effect is a phenomenon associated with high frequency signals (for example, higher than 50 kHz or so). The higher the frequency, the greater the effect. Flat strap has less skin effect than a round conductor, therefore, is the preferred method to ground an RF SPD (see Figure 7-32). See *Newton’s Telecom Dictionary*.

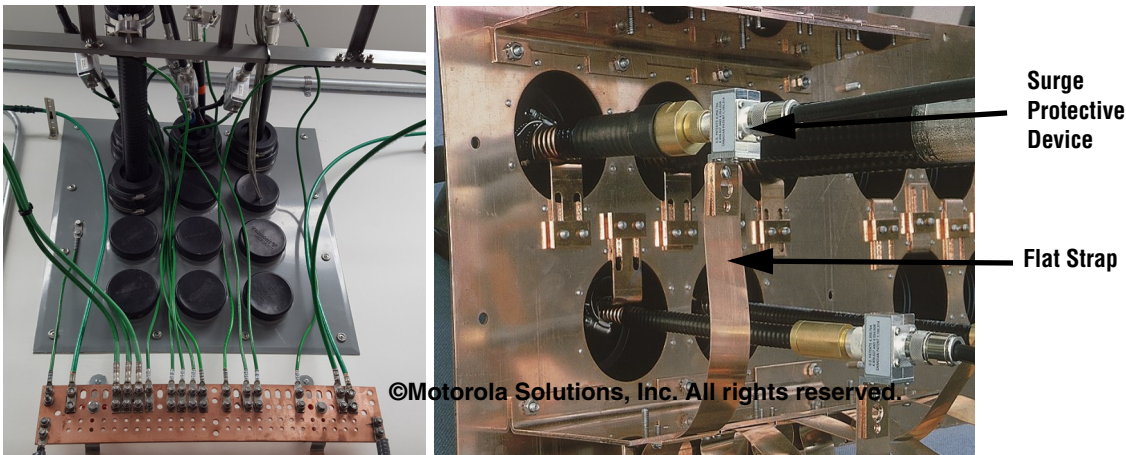

Figure 7-32 Examples of RF SPD Bonding - Round Conductor and Flat Strap (Preferred)



IMPORTANT

All coaxial cables (including unused spares) entering the communications facility (or communications room in a larger building) shall be bonded and grounded as described in Chapter 4, “External Grounding (Earthing) and Bonding”. Additionally, these coaxial cables shall have RF SPDs installed as described in this chapter. Unused coaxial cables entering the communications facility (or communications room in a larger building) shall be terminated at the RF SPD with a short or 50 ohm load.

7.11.1 RF Surge Protection Design

Coaxial SPDs are low impedance filters or lightning arrestors designed as either DC Pass or DC Block (see Figure 7-33). The DC Pass SPD is designed to allow a prescribed level of DC voltage to travel on the coaxial cable for the purpose of powering tower mounted electronics (for example, a tower-top amplifier). DC Block is designed to block all DC signals, allowing only RF frequencies to pass through the device. RF SPDs equalize lightning voltage between the shield and the center pin and allow for wideband lightning events to be shunted away from the equipment it is protecting. See Table 7-4 for recommended RF SPD requirements.

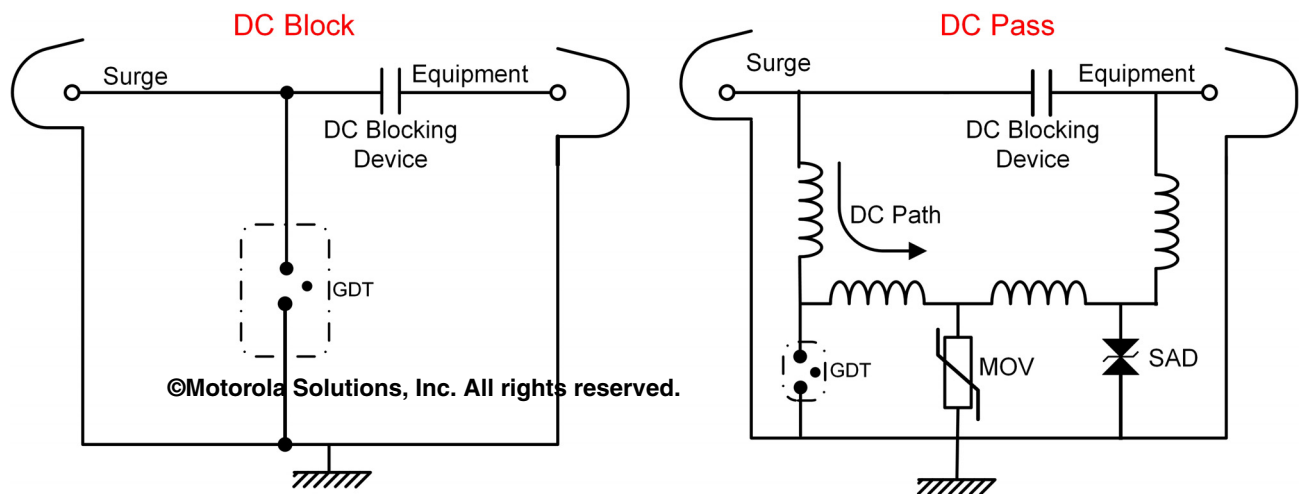

Figure 7-33 DC Block and DC Pass RF SPD Circuits

7.11.2 RF Surge Protection Technology Overview

Three common technologies are used in the design of RF surge protective devices:

- Simple Gas Tube Designs
 - Replaceable Gas Tube (RGT), DC pass
 - Non-replaceable gas tube, DC Pass (not recommended for critical deployments)
 - Low frequency gas tube, DC block
- Quarter Wave Stub
 - DC Short
 - DC Pass – Hybrid incorporating a gas tube
- Broadband High Band Pass Filter
 - DC Block
 - DC Pass - RF filter incorporating hybrid solid state and gas tube

7.11.2.1 Replaceable Gas Tube

A straight gas tube-based coaxial protector without DC blocking has DC continuity from the surge-side connector center pin to the equipment-side connector center pin. The fast rise-time lightning pulse can produce a high magnitude voltage across the gas tube before the gas can ionize and begin to conduct. Because there is no DC blocking mechanism, this high voltage impulse is applied directly to the equipment input before the gas tube “turns on.” If the protected equipment input routes through a ferrite circulator/isolator, the incoming pulse is converted to current in the ferrite's resistive load. This creates a magnetic field that can realign the critically adjusted field in the circulator, thereby changing the magnet's flux density. This can damage or destroy the resistive load. If the incoming voltage pulse appears across a coupling loop (as in most filters and

combiners), it sees a low resistance short and is almost entirely converted to current. A DC-shortened equipment input loop, which is quite common, directly shorts the gas tube. The gas tube may never see enough voltage to “turn-on” because current flow must go through the coaxial cable jumper and equipment input before an inductive voltage drop across the gas tube can reach a potential high enough to ionize the gas. Do not assume that a 90V gas tube will provide a 90V protection level for the equipment, because the voltage rating is based on a static DC voltage measurement. The gas tube is essentially a voltage dependent switch that reacts to the dv/dt of a lightning impulse. The typical voltage breakdown level for a $5kV/\mu s$ impulse is approximately $700 V_p$.

Straight gas tube protection devices allow DC current and voltage to be supplied to the tower top electronics. It is important to understand the operating characteristics of this protection technology. Tower top electronics consists of semiconductor-based preamplifiers, power supplies, diplexers, telemetry and so on. Coordination of protection levels of the gas tube-based devices and the susceptibility of the protected electronics must be taken into account.



IMPORTANT

The high frequency and high voltage of lightning results in fast rise time (to peak less than $8\mu s$) transient events. Caution shall be taken where straight gas tube arrestors are concerned. Potentially destructive energy may reach transmission equipment before the arrestor can activate. Also, gas tube arrestors have a limited life expectancy. Replacement of the GDT component or device every 1-2 years is recommended. Gas tube arrestors are not recommended for mission critical applications.

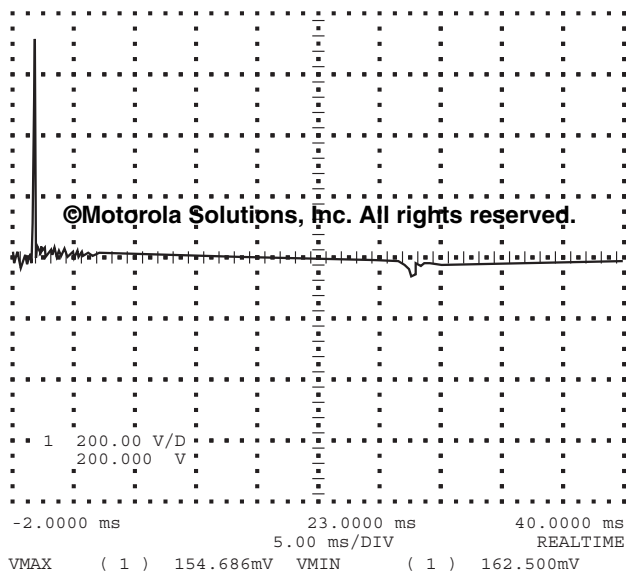

Figure 7-34 Gas Tube at 200V/div V and 5 μs /div H, 8x20 μs /3kA

7.11.2.2 Quarter Wave Stub

The “Quarter Wave Stub” coaxial protector is based on the well-known bandpass/band-reject principle. Using a coaxial **T** fitting and calculating the length of a quarter-wave coaxial section from the horizontal center conductor to the grounded (earthed) base of the **T** can form a bandpass filter at a given frequency. Because most of the energy in a lightning strike is from DC to 1 MHz, it falls on the lower frequency reject side of the bandpass filter and is conducted to ground (earth). However, because the equipment input is usually DC-shortened to chassis or earth and because the quarter-wave stub is connected to earth with an inductive copper conductor, there will be divided DC and low-frequency energy flowing into the equipment input.

Quarter-wave devices cannot be used where DC currents and voltages are required to power RF electronics. By their nature, they are tuned devices and therefore have relatively narrow operating bandwidths (approximately $\pm 10\%$ of the operating frequency).

Shorted inductor (or shorted stub) lightning surge protective devices can appear electrically as an open circuit or a short circuit, depending on the applied radio frequency and physical dimensions of the transmission line inductor or stub. Within the

designed frequency band, the shorted inductor or stub appears as an infinite impedance, producing very little passive insertion loss. Shorted inductors are indeed “shorted” at DC and frequencies outside the designed passband.

Shortcomings of the shorted inductor lightning protector that must be considered include that it will pass on-frequency lightning energy. The shorted inductor lightning protector must be made of compatible, non-ferrous materials, otherwise it can become a source of Passive Intermodulation (PIM). The shorted inductor will not allow DC to pass; therefore it is not suited in CCTV, tower top amplifier and GPS receiver applications where DC bias is multiplexed on the RF transmission line.

Shorted stub inductor lightning protectors that place a neon tube device in series with the tuned circuit to provide DC isolation are available. Although this solves the DC voltage problem for tower top amplifier and GPS applications, it significantly limits current-handling capacity of the protection device and does not reduce the let through voltage to the level required for equipment survivability; therefore such devices **shall not** be used.

The shorted stub inductor device is frequency-sensitive, therefore it must be selected for the specific frequency band in use. Different bands multiplexed on the same transmission line will not work with band-limiting devices such as the shorted stub inductor. The shorted stub inductor device is mechanically large compared to other gas protector/reactive filter lightning surge protector devices in common use. There could quickly develop an installation space problem if a number of transmission lines are protected by individual shorted stub inductor devices at the common facility cable entrance port. The shorted inductor type device differs somewhat from the shorted stub inductor type device in that the shorted inductor type device incorporates a helical wound shorted inductor. These devices typically exhibit an open DC circuit through the device and have a much larger bandpass than a shorted stub inductor device.

All coaxial RF surge suppression devices **shall** exhibit an open DC circuit through the device (unprotected port center pin to protected port center pin), except those specifically designed to pass DC for CCTV, tower top amplifiers and GPS installations as described in this chapter and “GPS Receiver Protection” on page 7-48. The input and output ports **shall not** be directly connected and may have a capacitive or reactive network installed within the device to permit the RF energy to pass. The unprotected port and the protected port **shall** be clearly marked on the device.

Typical RF characteristics for RF SPD are Voltage Standing Wave Ratio (VSWR) of less than or equal to 1.1:1 (return loss of -26.4dB) and an insertion loss of less than or equal to 0.1 dB over the network operating frequency range. These devices are also specified to handle surge currents from 10-20kA 8/20 μ s waveform. Selection of the proper SPD for RF transmission lines depends on the specific application.

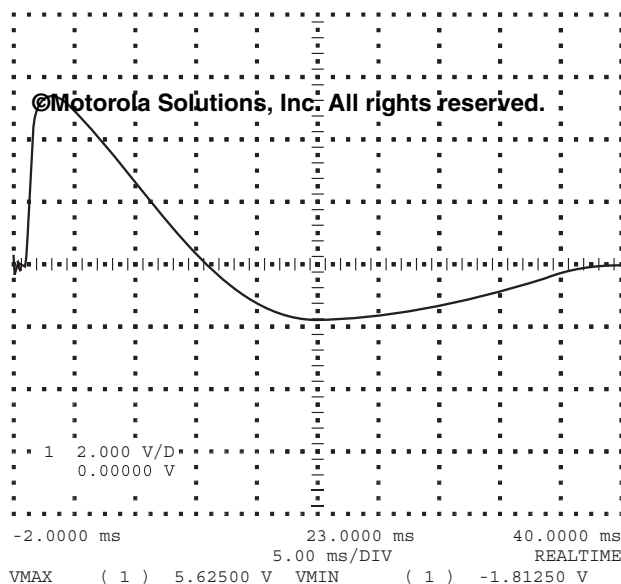

Figure 7-35 Quarter-Wave stub, Oscilloscope Set at 2V/div V and 5 μ s/div H, 8x20 μ s/3kA

7.11.2.3 Filter-based Coaxial Protectors

Filter-based lightning protection devices are characterized by their broadband performance characteristics and can cover multiple transmit/receive frequency bands. These cavity-based designs can be characterized as bandpass filters. They consist of tuned inductive capacitance (LC) networks operating on a bandpass/band-reject principle, with an operating band as broad

as 2 GHz. Utilizing the inductive current discharge circuit to shield/ground, followed by a DC blocking capacitive component on the center pin, ensures not only broadband RF performance, but also the desired surge suppression characteristics. Designs based on this principle allow a closer match to 50 ohms over a broader range than the quarter-wave technique. These devices cannot be utilized in applications where DC currents and voltages are supplied to the RF electronics via the coaxial cable's center conductor.

A modified form of this filter-based technology can be deployed in applications requiring DC power for the tower top electronics. There are designs combining DC blocking for the RF while passing DC power for the tower top electronics. The design is similar to the Bias-T concept. While the RF surge performance relies on the filter concept, the DC path is isolated from the RF path, conditioned and re-injected at the appropriate port. While selecting this type surge protector, attention should be paid to the resistance of the DC protection circuit. The typical DC resistance range could be from a few milliohms to a few ohms.

The proper SPD **shall** be selected based on the application.

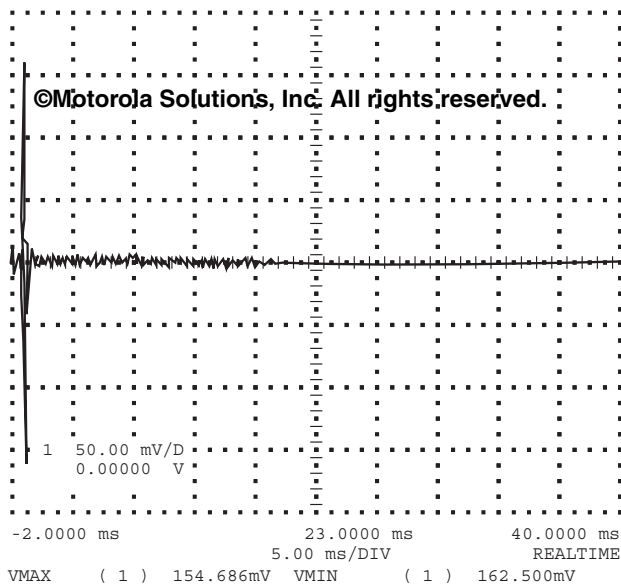

Figure 7-36 Filter-Based RF Protection Device, Oscilloscope Set at 0.05V/div V and 5μs/div H, 8x20 μs/3kA

7.11.3 RF SPD Qualifications

The RF SPD used **shall** meet the specific requirements of the application (see ATIS-0600334.2013, section 7.8.1.3, for more information). Motorola Solutions recommends the following minimum specifications:

Table 7-4 RECOMMENDED MINIMUM RF SPD QUALIFICATIONS

RF SPD Qualifications		
Parameter	Value	Notes
Listing	UL 497C	
Mounting	Flange or bulkhead	Site specific according to the entry panel style.
Connector Type and Gender	Application specific	Type N or DIN for RX and single channel TX. DIN type for combined TX channels (multi-carrier). Adapters shall not be used.

Table 7-4 RECOMMENDED MINIMUM RF SPD QUALIFICATIONS (CONTINUED)

RF SPD Qualifications		
Parameter	Value	Notes
Frequency Range	Application specific	Operating frequency range of the system.
Continuous RF Power Rating	Application specific	To be determined by the system engineer.
Maximum Peak Instantaneous Power (PIP) Rating	Application specific to be determined by the system engineer.	Must be considered when selecting suitable lightning protectors for multi-carrier transmitter combiner applications for P25 Phase 2, TETRA and similar digital modulations. Consultation with the system engineer and/or SPD manufacturer is recommended.
VSWR (Return Loss)	1.1:1 (-26 dB) for DC Blocking 1.2:1 (-21 dB) for DC passing	Over the specified frequency range of the SPD.
Insertion Loss	No more than 0.1 dB	Over the specified frequency range of the SPD.
DC Pass	Application specific	Typical for systems using tower mounted amplifier (TMA) or tower-top amplifier (TTA).
Surge Rating	40kA maximum for a single test strike. 20kA for multiple test strikes.	Using an IEC 61000-4-5 defined 8/20 μ s waveform.
Let through Voltage	No more than 200 mV for DC blocking. Application specific for DC passing (based on DC voltage used).	Using a 3kA 8/20 μ s waveform.
Passive Intermodulation (PIM) Rating NOTE: See “Antenna Network Components” on page 8-6 for more information and requirements.	Application specific. Where required: less than -150 dBc (-107 dBm); 2 X 20 W input	PIM Rating required on the TX line for combined TX channels (multi-carrier). PIM Rating for RX channels is optional.
Minimum Weatherization	IEC 60529 IP67 Telcordia GR-487	
Restriction of Hazardous Substances (RoHS) Compliant	Yes	

**NOTE**

See “RF Connectors” on page 9-55 for information regarding connector installation techniques needed for proper return loss and PIM performance.

**IMPORTANT**

Improper connector torque can result in degraded return loss and/or Passive Intermodulation (PIM) performance.

7.11.4 Tower Electronics

Tower electronics (for example, a tower-top amplifier or tower mounted amplifier, access points, wireless routers and so on) **shall** be bonded to the tower as described in “Tower-Mounted Devices” on page 4-126 (see Figure 7-37). Tower electronics **shall** be protected from surge events. Appropriate Surge Protective Devices (SPD) **shall** be installed and bonded to the tower as close as practicable to the tower mounted electronics and within 61 cm (24 in.) of the entry point to a communications facility.

RF SPDs **shall** meet the requirements of “RF Surge Protection” on page 7-38. CAT 5/6 SPDs **shall** meet the requirements of “Broadband Point-to-Point and Multi-point Wireless Links” on page 7-35 and “SPD Summary and Performance Evaluation for Telephone, Data, Signaling and Network Circuit Protection” on page 7-32.

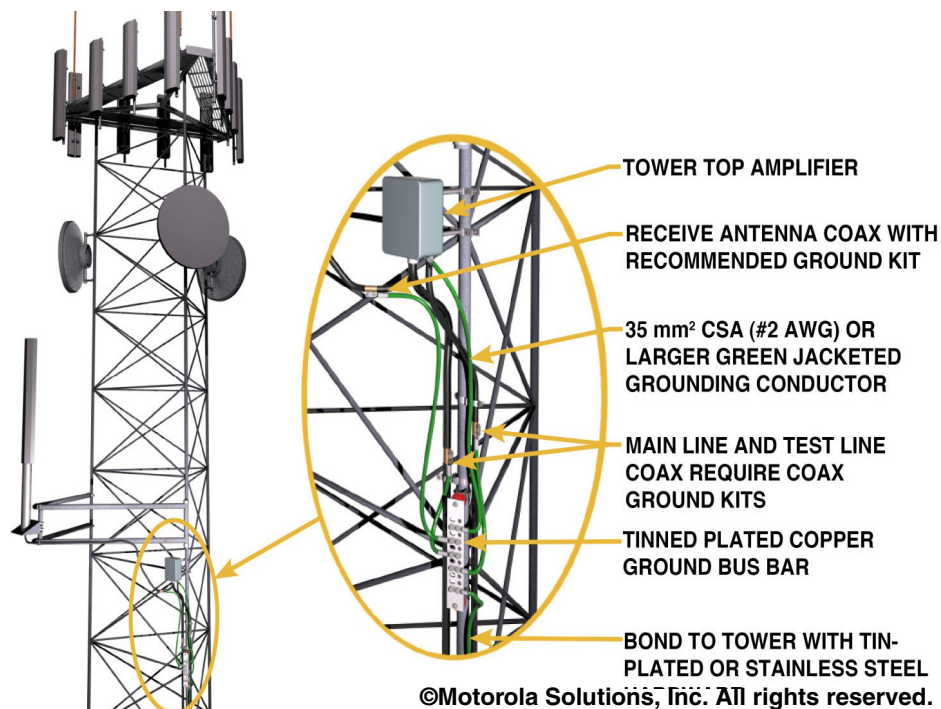

Figure 7-37 Tower Amplifier Grounding and Bonding



IMPORTANT

Many tower-mounted amplifiers have RF SPDs integrated into the design. An RF SPD must still be installed at the communications facility entry point as described in this chapter.

7.11.5 GPS Receiver Protection

Global Positioning System (GPS) receivers are often a part of modern communications systems. GPS receivers are used for site timing and synchronization. Failure of a GPS receiver can render the radio site or system unusable. Surge Protective Devices (SPDs) **shall** be installed on GPS signal cables within 61 cm (24 in.) of the point of entry to the equipment area. The design of the GPS receiver system typically includes an amplified GPS antenna unit and low-loss transmission line. The GPS antenna includes a GaAsFET device wideband RF amplifier. The RF amplifier is fed with low-voltage DC, typically 5V (but as high as 15 VDC). The GPS receiver system can incorporate a multiplex arrangement using a single coaxial transmission line, which also serves to couple the incoming GPS signal from the antenna to the receiver or by RS422 twisted pairs.

Coaxial and twisted pair cables **shall** be bonded according to “Grounding and Bonding of RF Transmission Lines and Other Communications Cables” on page 4-97.



IMPORTANT

Before selecting a coaxial SPD, verify that the GPS receiver can operate with an SPD in the coaxial line. In some installations, the GPS receiver will require optimization to compensate for the delay caused by the SPD and the variations in the length of the transmission line (which is site specific). The GPS antenna transmission line shall be cut to the proper length (or as instructed by the GPS receiver manufacturer), and excess transmission line shall not be coiled either inside or outside the shelter, room or equipment area.

7.11.6 Tower Lighting



IMPORTANT

Tower lighting cables shall not be bundled along with transmission lines or other conductors anywhere within cable ladders or the building interior.

If the tower lighting controller is installed within the building, shelter, room or equipment area, it **shall** be located as close to the cable entrance port as practicable. All control unit metallic housings **shall** be bonded to the Interior Perimeter Bonding Bus (IPBB), Primary Bonding Bar (PBB) or Secondary Bonding Bar (SBB), based on their location.

Strobe lighting systems may use voltages in excess of 600 VDC. Therefore, installation of a surge suppressor on these power conductors to the strobe light heads is not reasonable and will not adequately reduce surge voltages that may enter the shelter. For this reason, it is recommended that tower lighting controllers be located outside the shelter. Suppressing voltage transients on the AC power, alarm and control units located outside the shelter, building or equipment area can be effectively done by installation of a suitable SPD at the point of entry of the conductors into the shelter, building or equipment area. Tower light AC power, alarm and control cables **shall** enter the shelter, building or equipment area within or adjacent to, the antenna transmission line entry port location. The grounding conductors of the SPDs **shall** be bonded to the PBB or SBB.

Some tower lighting manufacturers offer an optional surge suppression device that may be installed within the tower lighting control unit. Although this device may be suitable for protecting the control unit circuitry, it does not provide adequate protection to inductively coupled energy that may enter the shelter, building or equipment area through the tower light power or control conductors.

Suitable surge suppression devices offering protection for AC power, control and modem circuits are available from several surge suppression device manufacturers. Devices **shall** be selected based on the specific application and requirements specified in this section.



IMPORTANT

Tower strobe light controllers should be located outside of the shelter (see Figure 7-38).



Figure 7-38 Tower Light Controller Installation

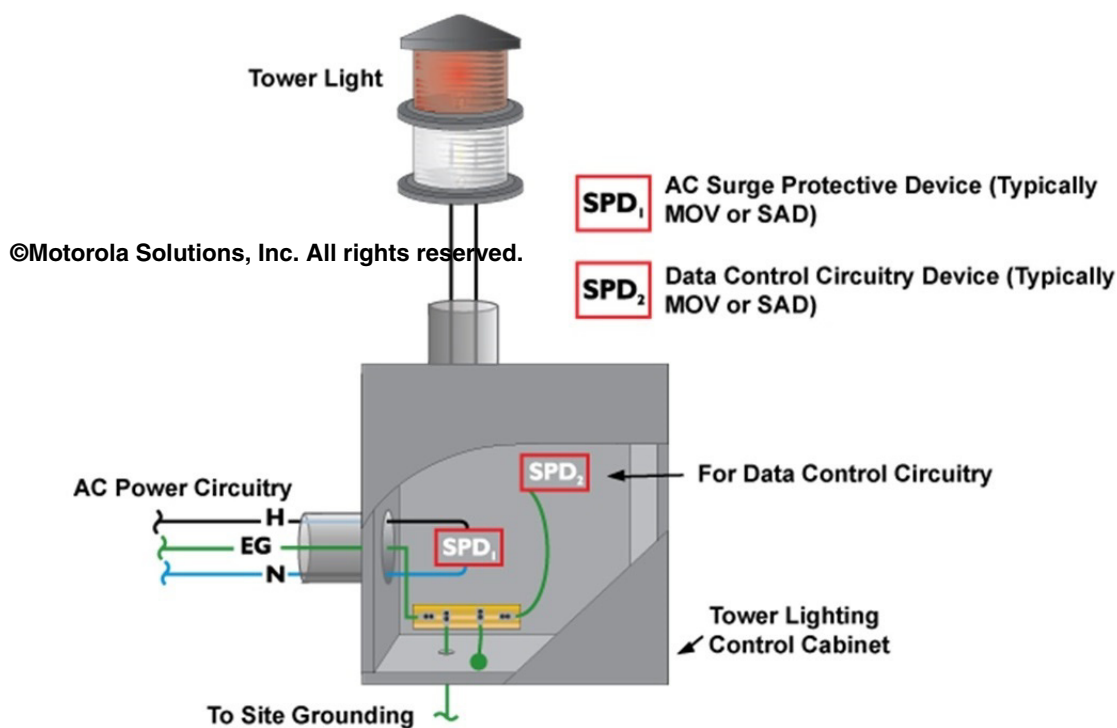

Figure 7-39 Example of Surge Protective Devices for Tower Lighting

7.11.7 Surge Protection Considerations for Dispatch Centers and Operator Positions

Dispatch and command operations are the nerve center for all mission critical communications networks. Often housing network master sites, data management and storage, personnel and multiple antenna systems, dispatch centers require greater attention to safety and systems maintainability. The critical nature of dispatch centers and the inherent higher risk to personnel from lightning discharge requires a well-engineered common bonding and grounding backbone, and surge protection designed for overvoltage mitigation.

For optimum protection and system availability, the following **shall** be considered for new designs and facility upgrades:

- Site design recommendations given in “Design Considerations to Help Reduce Effects of Lightning” on page 2-16.
- Internal bonding and grounding as defined in “Bonding and Grounding (Earthing) for Dispatch Centers and Network Operator Positions” on page 5-133.
- External grounding (earthing) and bonding as defined in Chapter 4, “External Grounding (Earthing) and Bonding” and “Dispatch Centers Co-Located With Communications Towers” on page 4-122.
- Electrostatic Discharge (ESD) precautions as defined in Appendix C, “Protecting Against Electrostatic Discharge in Equipment Rooms and Dispatch Centers”.
- Surge Protective Devices (SPD) as described in the following subsection.

7.11.7.1 Minimum SPD Requirements for Dispatch Centers and Operator Positions

- Type 2B SPD **shall** be installed at the electrical service entrance for the facility according to this chapter.
- Type 2A SPD **shall** be installed at the AC service panels in the equipment room and dispatch operations room, if applicable, according to this chapter.
- Type 3 SPD (for example, point of use and rack mounted PDUs) **shall** be required for critical equipment at each dispatch operator position. See “Type 3 Point of Use Surge Protective Device” on page 7-16. The Type 3 device external ground (earth) stud or connection point **shall** be bonded to the operator position bonding bar (see ATIS-0600321.2015).

- Telephony, CCTV, Ethernet, PoE, Cable Television and Alarm Circuits **shall** be surge protected according to “Telephony, Data, Signaling, Alarm and Network Circuit Protection” on page 7-21 and “Closed Circuit Television and Security” on page 7-34.
- See Figure 7-40 for an example of a typical SPD installation at a dispatch center.

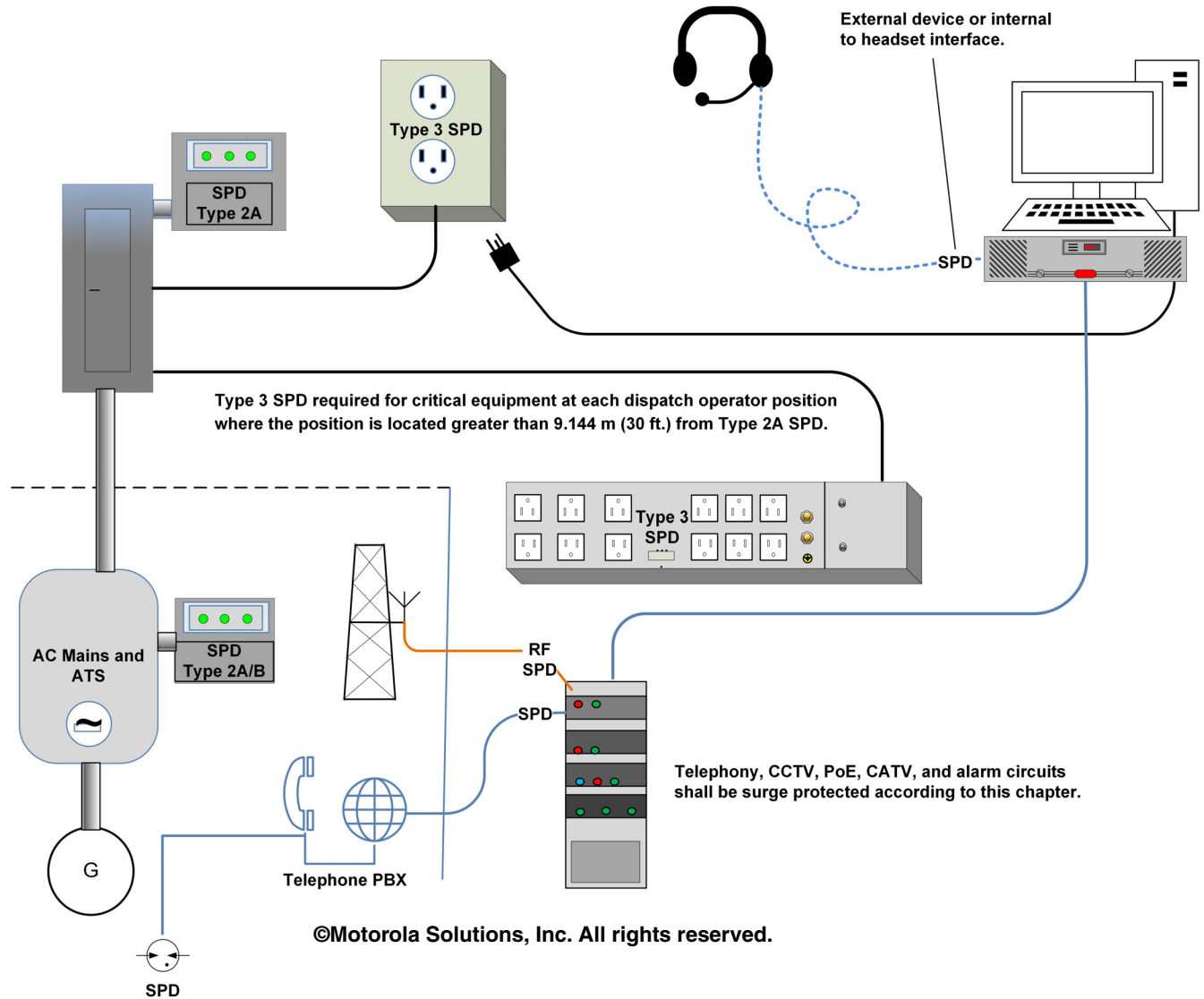

Figure 7-40 Example of Surge Protection Planning for Dispatch and Operations

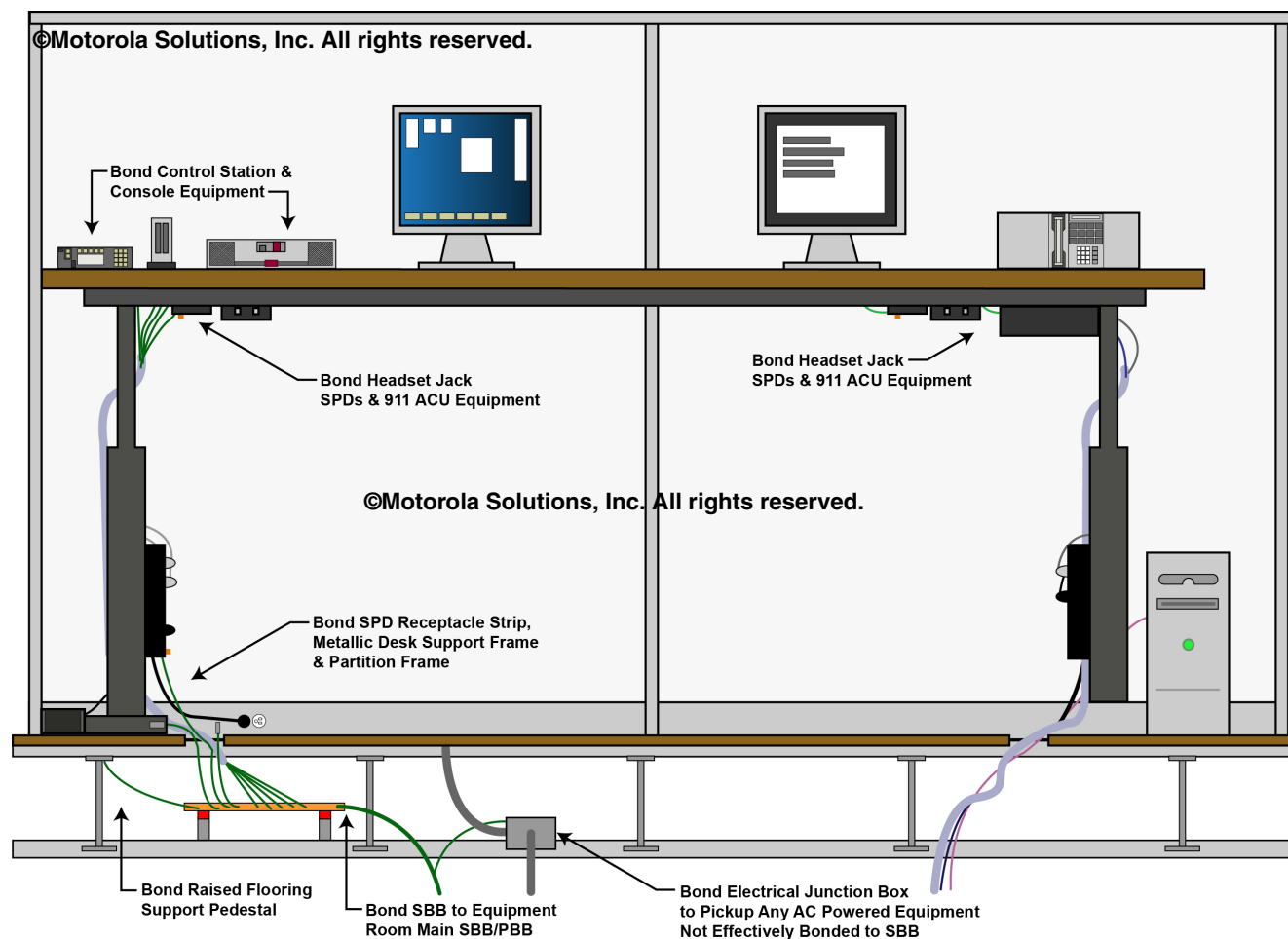

Figure 7-41 Example of Operator Position Bonding and Surge Protection



IMPORTANT

ESD is generally the cause for many complaints generated by dispatch personnel. Measures to control ESD shall be taken when designing for this environment. Most ESD problems are mitigated through proper bonding and grounding techniques, relative humidity control (between 40% and 55% relative humidity is ideal), attention to the resistivity of flooring and furniture, and selection of video display terminals (LCD or LED instead of CRT). See Appendix C, “Protecting Against Electrostatic Discharge in Equipment Rooms and Dispatch Centers”, for more information.

7.12 Direct Current Systems Surge Protection

Battery powered networks offer greater isolation from electrical noise, regulation fluctuation and electrical fault. A battery system will attempt to normalize voltage, absorbing variations in voltage. Localized DC distribution combined with battery backup improves component longevity and system availability during disruptions to the electrical grid. However, surge events are not uncommon and are potentially more damaging. DC power supplies are typically designed to operate with a lower Maximum Continuous Operating Voltage (MCOV) threshold. Therefore, DC power supplies are susceptible to fast transient overvoltage anomalies and induced Electromagnetic (EM) fields resulting from lightning caused Ground Potential Rise (GPR). Motorola Solutions recommends the surge protection practices described in the following subsections for DC systems that power outdoor electronics and localized DC distribution (for example, +24V or -48V).

7.12.1 DC Powered Outdoor Equipment

Radios, Low Noise Amplifiers (LNA), Tower Mounted Amplifiers (TMA), Point-to-Point (PTP) broadband and other electronics installed on communications towers, along roof lines or on utility poles **shall** incorporate on-board or external DC surge protection located within 0.6 m (24 in.) of the protected load, or as close as practicable. Protection for Power over Ethernet (PoE) DC conductors may be incorporated into a common SPD for the twisted pair cable (see Table 7-3). DC conductors (PoE or separate conductors) **shall** be surge protected with an SPD within 61 cm (24 in.) of entering the communications facility according to this chapter. See “Recommended DC SPD Technology and Location” on page 7-54 and NFPA 70-2017, Articles 800, 820 and 830.



IMPORTANT

Electronics designed for outdoor use often incorporate a basic level of surge protection. Board-level surge protection, while simplifying installation, also has inherent problems. Board-level SPDs afford limited isolation from lightning-induced EM fields. An SPD board failure may necessitate replacing the entire radio. The potential for such occurrences must be carefully considered where mission critical equipment is concerned.

7.12.2 Localized DC Distribution

DC distribution systems consist of AC to DC converters, battery banks, low-voltage main distribution frames and distributed DC load centers. A Type 2A Surge Protective Device (SPD) **shall** be installed at the AC service panel feeding the systems converters, according to this chapter. Surge protection on the DC system load center is recommended.

The DC SPD recommendations are as follows:

- DC SPDs for critical loads are recommended where the critical loads are located more than 9.144 m (30 ft) from the DC power distribution point.
- DC SPDs for critical loads are highly recommended for geographic locations of high-lightning activity, where the critical loads are located more than 9.144 m (30 ft) from the DC power distribution point. High-lightning areas are defined as areas with lightning flash density greater than 2 flashes/km²/year. See “Lightning Activity and Exposure” on page 4-3 for more information.
- DC SPDs for critical loads are highly recommended for all geographic locations where the critical loads are located more than 15.2 m (50 ft) from the DC power distribution point.
- DC SPDs are recommended for all loads located more than 15.2 m (50 ft) from the DC power distribution point.
- See Figure 7-42 for an example of a recommended DC SPD installation.



NOTE

The system engineer, system manager and/or the system owner **shall** define the critical load(s). A critical load is generally considered any load that impacts system availability and the end-user’s ability to effectively communicate on the system.



IMPORTANT

The DC Power System shall be bonded and grounded according to “DC Power Systems” on page 5-89 and applicable subsections.

Lightning-induced Electromagnetic (EM) fields or an incorrectly grounded DC system can result in potentially damaging transient overvoltage events under lightning conditions. A lesser threat, but with possible catastrophic consequences, is capacitive discharge of the battery bank. Capacitive discharge is a near instantaneous release of energy in the affected cells. Voltage discharge can range from hundreds of volts to thousands of volts.

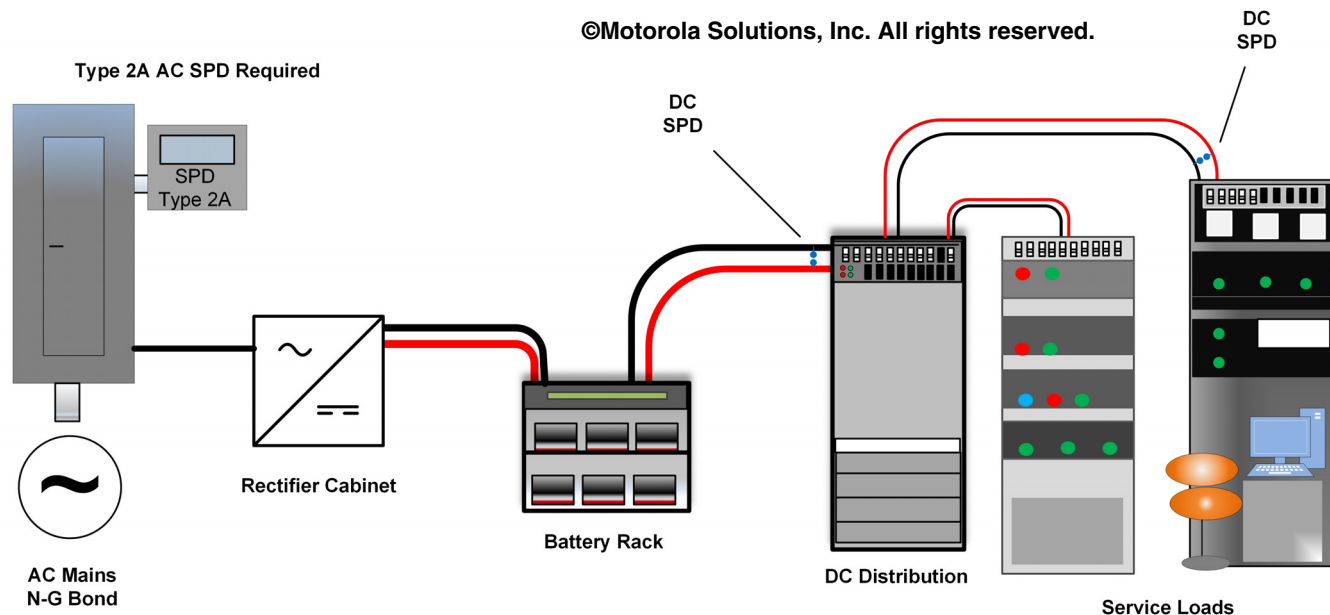

Figure 7-42 Example of Recommended DC SPD Installation

7.12.3 Recommended DC SPD Technology and Location

The recommended DC SPD should be constructed using a Metal Oxide Varistor (MOV), Silicon Avalanche Diode (SAD) or an SAD/MOV matrix device.

When selecting a DC SPD, it is important to consider wire size and the SPD's Maximum Continuous Operating Voltage (MCOV). DC systems can carry a considerable amount of energy. The SPD voltage rating **shall** be closely coordinated with the circuit voltage and polarity of the battery plant.

Key specifications of the DC SPD are as follows:

- SPD minimum conductor size of 5.26 mm² csa (#10 AWG) for parallel connected SPD or sized for peak current load for series connected SPD.
- MCOV between 75V and 90V maximum for -48VDC service, 35V to 55V maximum for +24VDC service.
- Surge Rating 200V peak maximum at 1000A 8×20 μs, 150A 10x1000 μs.

DC SPDs are **required** as follows:

- As described in “DC Powered Outdoor Equipment” on page 7-53.
- As described in “Localized DC Distribution” on page 7-53.
- For any DC conductor penetrating the shelter wall within 60.96 cm (24 in.) of entering the shelter (see Figure 7-44).

To maximize the effectiveness, the SPD should be installed at the equipment to be protected. Additional devices are recommended for each DC equipment load at the site.

Suitable surge suppression devices are available from several surge suppression device manufacturers. Devices **shall** be selected based on the specific application and requirements specified in this section.

DC surge events occur on the ungrounded side of the DC circuit (for example, Negative for -48VDC and Positive for +24VDC and +12VDC). This level of protection is sufficient for load protection, or within 1.8 m (6 ft) of the protected load.

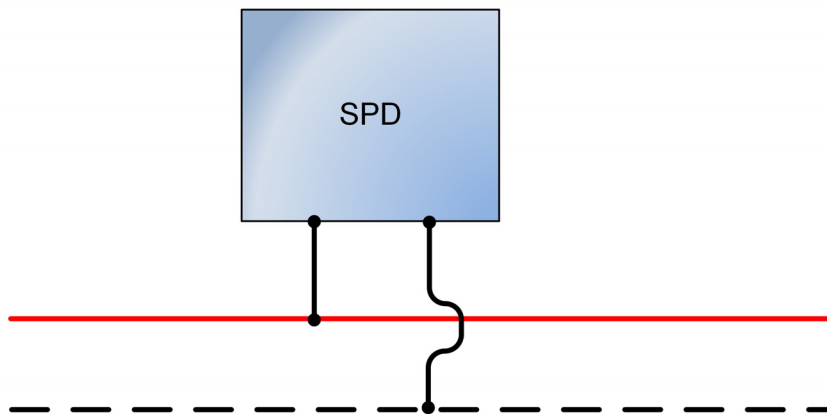

©Motorola Solutions, Inc. All rights reserved.

The All Mode SPD is recommended for DC supply protection, after the DC ground has been established. Solid state SPDs between the DC positive and negative combined with an SPD to ground helps to mitigate induced EMI.

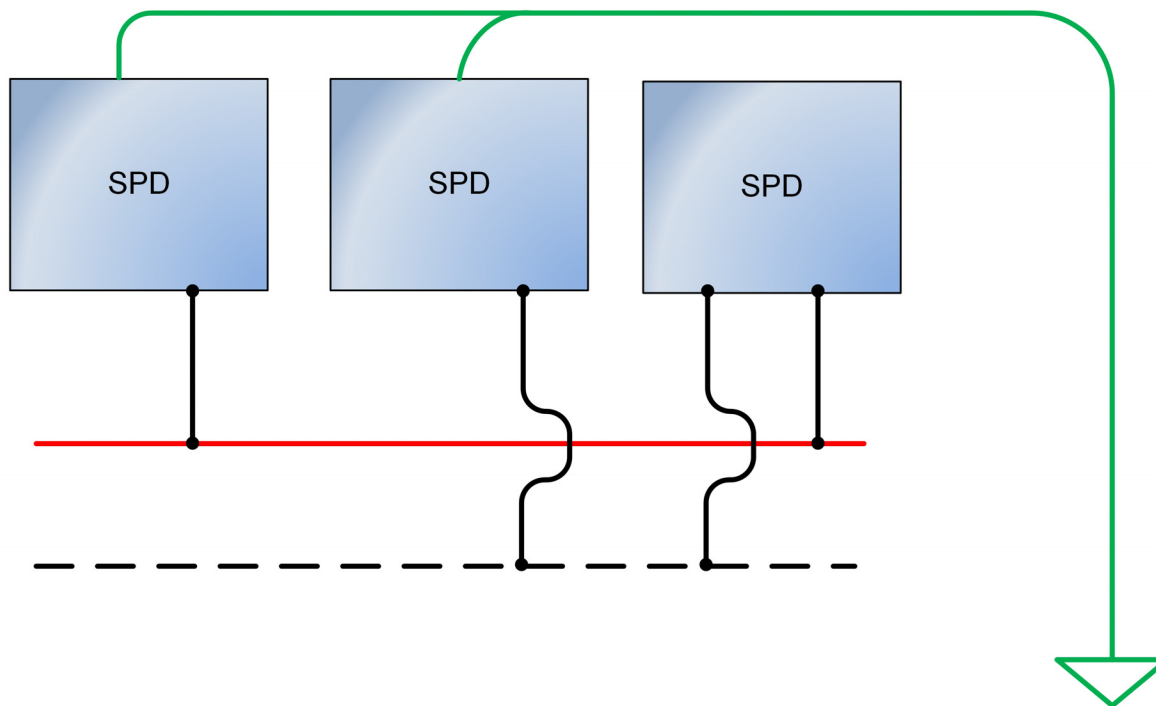

Figure 7-43 DC Surge Protection Modes

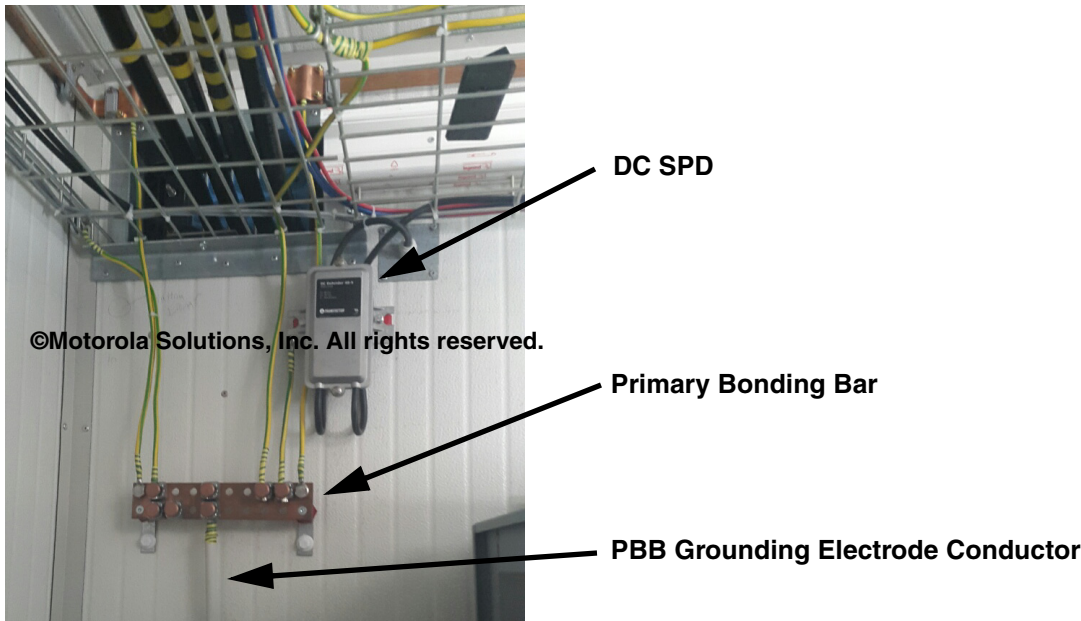

Figure 7-44 Example of DC SPD Installed on DC Conductor Entering a Shelter

7.13 AC Power Line SPD Test Certification Requirements

AC power line SPDs which are recommended, distributed or installed by Motorola Solutions **shall** meet the specifications requirements cited in “AC Power Surge Protective Devices (SPD) Requirements” on page 7-9 and those specified in Table 7-2. Additionally, these devices **shall** have been certified as meeting the criteria cited in “Impulse Surge Durability Test Requirements” on page 7-57.

Manufacturers of AC power line surge suppression devices **shall** have the SPD tested using an independent Nationally Recognized Testing Laboratory (NRTL), NAVLAP or A2LA, or a Certified UL client testing data laboratory. The test procedures used and the results obtained **shall** be made available to Motorola Solutions.

Each manufacturer will submit and test their products for compliance with the specifications cited in “AC Power Surge Protective Devices (SPD) Requirements” on page 7-9 and in Table 7-2. These tests **shall** follow the procedure outlined in “Impulse Surge Durability Test Requirements” on page 7-57 and **shall** be done at no cost to Motorola Solutions. The results of these tests **shall** be certified by the independent laboratory and **shall** be submitted to Motorola Solutions for review. Devices that have been tested following the procedure established in this section and found to be compliant with the specifications cited in “AC Power Surge Protective Devices (SPD) Requirements” on page 7-9 and those specified in Table 7-2 **shall** be considered to have met the device requirements established by Motorola Solutions.

Motorola Solutions **shall** be afforded the opportunity to have their representative or representatives present at the time of the testing to witness and verify the test data compiled by the independent laboratory. The manufacturer may request that the test results be considered proprietary and may request that the information not be disclosed by representatives of the independent laboratory or Motorola Solutions. Motorola Solutions **shall** be notified 30 days prior to the test in order to facilitate scheduling to witness the testing. After completion of the testing, manufacturers will have 30 days to compile the testing data and submit to Motorola Solutions for review. Motorola Solutions will have 60 days to advise the manufacture as their acceptance or refusal of the results of the test data.

Motorola Solutions, at their option and expense, may purchase additional units from the manufacturer’s normal production and have these devices tested by an independent laboratory of their choice following the same test criteria. Should it be found that the units purchased fail to meet the requirements as defined in “AC Power Surge Protective Devices (SPD) Requirements” on page 7-9 and Table 7-2, the manufacturer **shall** be notified. Motorola Solutions may, at their option, discontinue recommending, distributing or installing the product at any time.

7.13.1 Test Methods

This section describes the required tests for Motorola Solutions certification. These tests are designed to stress the SPD to meet the requirements in this document. These are performance tests that exceed the UL 1449 4th edition safety test. In addition to these required tests, UL 1449 4th edition listing is required.

All tests for Type 2A and 2B SPDs will require a Pre-test of 6 kV (minimum), 10 kA 8x20 μ s Impulse as described in IEC 61643-1. The Voltage Protection Level (VPL) is then recorded. After the required tests are performed a Post-test of 6kV (minimum), 10kA 8x20 μ s Impulse as described in IEC 61643-1 will be performed. The result from the Post-test must be within 10% of the Pre-test VPL.

Each test will require one test sample.

7.13.2 Component Level Surge Test

7.13.2.1 General

This test will test the individual surge module(s) of Type 2A SAD/MOV and Type 2B MOV SPDs to show that they meet the requirements in this document. The SAD module(s) are required to meet 20 kA single impulse with the VPL not deviating more than 10% in pre and post I_n (Nominal) testing. The MOV module(s) are required to meet 160 kA single impulse with the VPL not deviating more than 10% in Pre-test and Post-test I_n (Nominal) testing. All referenced surge currents are based on 8x20 μ s waveforms.

7.13.2.2 I_n (Nominal Current Test)

The module(s) must first be subjected to an I_n test impulse as described in IEC 61643-1. The test current I_n is 10kA 8x20 μ s. The clamping voltage measured 150 mm (6 in.) from the module(s) connection is then recorded and the current waveform plotted.

7.13.2.3 Component Surge Test Calibration

The surge generator must be calibrated to the test current and the current waveform plotted as per UL 1449 4th edition. Calibration should be performed with the actual lead wires used to connect the module(s). This will allow the delivered current to closely match the short circuit current. Calibration for the SAD module(s) **shall** be 20 kA. Calibration for the MOV module(s) **shall** be 160 kA. No AC is required for this test. The clamping voltage measurement is not required for this test.

7.13.2.4 Module(s) Testing

The SAD module(s) are then subjected to the 20 kA impulse. The MOV module(s) are then subjected to the 160 kA impulse.

7.13.2.5 Pass Criteria

The modules are then subjected to the I_n 10 kA test as described in “ I_n (Nominal Current Test)” on page 7-57. The VPL is then measured and recorded. The current/voltage waveform is plotted. The Pre-test I_n VPL is compared to the Post-test I_n VPL. The modules passes the requirement if the Post-test VPL is within 10% of the Pre-test VPL.

7.13.3 Impulse Surge Durability Test Requirements

7.13.3.1 General

The impulse surge durability test is designed to test the endurance of the SPD. Each Type of SPD is subjected to its own set of impulses. For Type 2A SAD/MOV and Type 2B MOV devices the SPD is first subjected to a Pre-test I_n impulse, and its VPL is measured and recorded. After the duty cycle testing the SPD is again subjected to an I_n impulse, and its VPL is measured and recorded. The Post-test I_n VPL must be within 10% of the Pre-test I_n VPL. All referenced surge currents are based on 8x20 μ s waveforms except for the 100 kHz ringwave. The total number of impulses for each type is 400. Two hundred (200) impulses **shall** be applied positive at a phase angle of 90° (+0°, -15°), and 200 impulses **shall** be applied negative at a phase angle of 90° (+0°, -15°).

7.13.3.2 I_n Pre-test (Nominal Current Test)

The SPD must first be subjected to an I_n test impulse as described in IEC 61643-1. The test current I_n is 10 kA 8x20 μ s. The clamping voltage measured 150 mm (6 in.) outside of the enclosure is then recorded and the current and voltage waveform plotted.

7.13.3.3 Duty Cycle Calibration

The surge generator **shall** be calibrated as specified in UL 1449, 4th edition, section 37.3. Tolerances and waveform are described in UL 1449, 4th edition, section 37.3. This test is for Type 2A SAD/MOV and Type 2B MOV SPDs only. For Type 2A SAD/MOV SPDs a calibration of 6 kV, 3 kA and 6 kV, 10 kA is required. For Type 2B MOV SPDs a calibration of 6 kV, 3 kA is required. All calibration current waveforms must be measured and plotted.

7.13.3.4 SPD Duty Cycle Test

7.13.3.4.1 Type 2A SAD/MOV SPDs

The test voltage and current **shall** be a combination of pulses at 6 kV_p minimum at 3 kA and 6 kV_p minimum at 10 kA. This test **shall** consist of 20 impulses at 6 kV_p minimum / 10 kA, followed by 160 impulses at 6 kV_p / 3 kA, followed by 20 impulses at 6 kV_p minimum/ 10 kA respectively per polarity. The surges **shall** be conducted in succession with a maximum 60 second period between each surge. The total number of impulses being 400.

7.13.3.4.2 Type 2B MOV SPDs

The test voltage and current **shall** be a combination of pulses at 6 kV_p minimum at 3 kA. This test **shall** consist of 400 impulses at 6 kV_p minimum/ 3 kA. The surges **shall** be conducted in succession, with a maximum 60 second period between each surge. The total number of impulses being 400.

7.13.3.4.3 Type 3 SPDs

The test voltage and current, **shall** be 6 kV_p at 200 A and 100 kHz (ringwave test) as described by IEEE C62.41. This test **shall** consist of 400 impulses conducted in succession with a maximum 60 second period between each surge.

7.13.3.5 Pass Criteria

After duty cycle testing, the SPD is then allowed to cool to room temperature. The SPD is then subjected to the I_n 10 kA test as described in “ I_n Pre-test (Nominal Current Test)” on page 7-58. The VPL is measured and recorded. The current and voltage waveform is plotted. The Pre-test I_n VPL is compared to the Post-test I_n VPL. The SPD passes the requirement if the Post-test VPL is within 10% of the Pre-test VPL. For Type 3 devices if the SPD remains fully functional the unit passes.

7.13.4 Maximum Discharge Current Test

7.13.4.1 General

The Maximum Discharge Current test is designed to test the maximum surge capability of the SPD. Maximum Discharge Current, or I_{max} , for Class II Test is the crest value of a current through the SPD having an 8x20 μ s waveshape and magnitude according to the test sequence of the Class II operating duty test. I_{max} for Type 2A SAD/MOV and Type 2B MOV SPDs is 160 kA. The SPD **shall** be mounted and connected as per the manufacturer's installation instructions.

If manufacturer provides electrical conductors as a part of the product, testing and measurements **shall** be conducted on the full length of conductor provided.

If no electrical conductors are provided, testing and measurements **shall** be conducted at the terminal block.

Testing **shall** be performed in free air, 20 °C, \pm 15 °C.

During the testing, maintenance or modifications **shall not** be performed.

All referenced surge currents are based on 8x20 μ s waveforms.

7.13.4.2 I_n Pre-test (I Nominal Current Test)

The SPD must be first be subjected to an I_n test impulse as described in IEC 61643-1. The test current I_n is 10 kA 8x20 μ s. The clamping voltage measured 150 mm (6 in.) outside of the enclosure. The VPL is then recorded and the current and voltage waveform plotted.

7.13.4.3 I_{max} Surge Generator Calibration

The surge generator **shall** be calibrated as specified in UL 1449, 4th edition, section 37.3. Tolerances and waveform are described in UL 1449, 4th edition, section 37.3. This test is for Type 2A SAD/MOV and Type 2B MOV SPDs only. Calibration should be performed with the actual lead wires used to connect the module/s. This will allow the delivered current to closely match the short circuit current.

1. Calibrate the Surge Generator with an 8/20 μ s short circuit current of 16 kA. Denote and record the charge voltage of the surge generator. Measure, record and plot the short circuit current including peak amplitude, rise time and duration.
2. Calibrate the Surge Generator with an 8/20 μ s short circuit current of 40 kA. Denote and record the charge voltage of the surge generator. Measure, record and plot the short circuit current including peak amplitude, rise time and duration.
3. Calibrate the Surge Generator an 8/20 μ s short circuit current of 80 kA. Denote and record the charge voltage of the surge generator. Measure, record and plot the short circuit current including peak amplitude, rise time and duration.
4. Calibrate the Surge Generator with an 8/20 μ s short circuit current of 120 kA. Denote and record the charge voltage of the surge generator. Measure, record and plot the short circuit current including peak amplitude, rise time and duration.
5. Calibrate the Surge Generator with an 8/20 μ s short circuit current of I_{max} 160 kA. Denote and record the charge voltage of the surge generator. Measure, record and plot the short circuit current including peak amplitude, rise time and duration.

7.13.4.4 I_{max} Discharge Test

Connect the Positive Terminal of the Surge Generator to the L1 terminal or conductor of the SPD.

Connect the Negative Terminal of the Surge Generator to the N terminal or conductor of the SPD.

1. Apply a surge current of 16 kA with a positive polarity, no AC applied. Measure, record and plot the delivered current.
2. Apply a surge current of 40 kA with a positive polarity, no AC applied. Measure, record and plot the delivered current.
3. Apply a surge current of 80 kA with a positive polarity, no AC applied. Measure, record and plot the delivered current.
4. Apply a surge current of 120 kA with a positive polarity, no AC applied. Measure, record and plot the delivered current.
5. Apply a surge current of I_{max} 160 kA with a positive polarity, no AC applied. Measure, record and plot the delivered current.
6. Repeat Steps 1 through 5 of this procedure for the remaining modes of protection of the SPD.
7. Apply thermocouples to the top and two-sides of the SPD.
8. Connect the SPD to the voltage, phase and power circuit configuration as detailed on the data label.

9. Energize the SPD for a period of 30 minutes. Measure and record the temperatures obtained.

7.13.4.5 Pass Criteria

After I_{max} testing the SPD is allowed to cool to room temperature. The SPD is then subjected to the I_n 10 kA Post-test as described in “In Pre-test (I Nominal Current Test)” on page 7-59. The VPL is measured and recorded. The current and voltage waveform is plotted. The Pre-test I_n VPL is compared to the Post-test I_n VPL. The SPD passes the requirement if the Post-test VPL is within 10% of the Pre-test VPL.

During the Residual Voltage Measurement, Pre-conditioning and I_{max} Operating Duty Cycle Tests, the following conditions **shall not** occur:

- Emission of flame, molten metal, glowing or flaming particles through any openings (pre-existing or created as a result of the test) in the product.
- Ignition of the enclosure.
- Creation of any openings in the enclosure that results in accessibility of live parts.
- Opening, temporary or permanent, of overcurrent protective components.
- Errors resulting from a failure, temporary or permanent, in the indication circuitry.
- A supplementary protection device opening.

7.13.5 SPD Qualifications Summary

Table 7-5 provides a summary of the AC Surge Protective Device safety and performance qualifications.

- The manufacturer **shall** provide a report summarizing the requirements in this table.
- The test lab facilities **shall** be identified (Name, Address, Test Engineer).

Table 7-5 AC SPD SPECIFICATIONS FOR SAFETY AND PERFORMANCE

AC SPD Certification and Test Requirements	Demonstration Method	Notes
Part 1: General SPD Compliance Requirements (see “AC Power Line SPD Test Certification Requirements” on page 7-56)		
SPD shall be UL listed per 1449, latest edition, Type 2 SPD.	The manufacturer shall provide the UL E-file number or equivalent listing agency record.	For the purpose of this standard, VPR is establish for (L-N) surges only, using a combination waveform as specified in ANSI/IEEE C62.45 - 2002, 8x20 μ s, 6kV/3kA. The short circuit rating Asymmetrical Interrupt Current shall be 25kAic to 65kAic.
SPD surge module component shall be UL recognized per 1449 latest edition, type 4 component.	The manufacturer shall provide the UL E-file number or equivalent listing agency record.	
Part 2: Component Level Surge Testing Requirements (see “Component Level Surge Test” on page 7-57)		
	The manufacturer shall demonstrate the surge performance as described.	The component modules shall exhibit less than +/- 10% variance between pre-Nominal and-post Nominal Current Test when subjected to 10kA 8x20 μ s per IEC 61643-1 parameters.

Table 7-5 AC SPD SPECIFICATIONS FOR SAFETY AND PERFORMANCE (CONTINUED)

AC SPD Certification and Test Requirements	Demonstration Method	Notes
SAD Component Module Testing		
Pre-test 10kA 8x20 μ s.	Waveforms shall be documented.	See “I _n (Nominal Current Test)” on page 7-57.
Calibration Surge 20kA 8x20 μ s.	Waveforms shall be documented.	See “Component Surge Test Calibration” on page 7-57.
SAD Module Test 20kA 8x20 μ s.	Waveforms shall be documented.	See “Module(s) Testing” on page 7-57.
Post-test 10kA 8x20 μ s.	Waveforms shall be documented.	See “Pass Criteria” on page 7-57. Pre-test and Post-test measurements shall be compared to show pass/fail.
MOV Component Module Testing		
Pre-test 10kA 8x20 μ s.	Waveforms shall be documented.	See “I _n (Nominal Current Test)” on page 7-57.
Calibration Surge 20kA 8x20 μ s.	Waveforms shall be documented.	See “Component Surge Test Calibration” on page 7-57.
MOV Module Test 20kA 8x20 μ s.	Waveforms shall be documented.	See “Module(s) Testing” on page 7-57.
Post-test 20kA 8x20 μ s.	Waveforms shall be documented.	See “Pass Criteria” on page 7-57. Pre-test and Post-test measurements shall be compared to show pass/fail with less than 10% variance. The SPD functional indicators shall operate in the “same as new condition” with nominal AC power applied.
Part 3: SPD Impulse Surge Durability Testing (see “Impulse Surge Durability Test Requirements” on page 7-57)		
	The manufacturer shall demonstrate the surge performance as described.	The component modules shall exhibit less than +/- 10% variance between pre-and-post Nominal Current Test when subjected to 10kA 8x20 μ s per IEC 61643-1 parameters. At the discretion of Motorola Solutions, the Type 2B MOV testing may be judged redundant if all SPD functions and features are demonstrated under Type 2A SAD/MOV testing.
Motorola Solutions Type 2A SAD/MOV and Type 2B MOV Testing		
Pre-test 10kA 8x20 μ s.	Waveforms shall be documented.	See “I _n Pre-test (Nominal Current Test)” on page 7-58.
Duty Cycle Calibration Short Circuit Levels <ul style="list-style-type: none"> • 3kA 8x20 μs • 6kA 8x20 μs • 10kA 8x20 μs 	Waveforms shall be documented.	See “Duty Cycle Calibration” on page 7-58. Duty cycle calibration as per UL 1449 latest edition.

Table 7-5 AC SPD SPECIFICATIONS FOR SAFETY AND PERFORMANCE (CONTINUED)

AC SPD Certification and Test Requirements	Demonstration Method	Notes
Type 2A/2B SPD Duty Cycle Testing: <ul style="list-style-type: none"> • 20 strikes at 6kV / 10kA • Followed by 160 strikes at 6kV / 3kA • Followed by 20 strikes at 6kV / 10kA 	Waveforms shall be documented.	See “SPD Duty Cycle Test” on page 7-58.
Post-test 10kA 8x20 μ s.	Waveforms shall be documented.	See “Pass Criteria” on page 7-58. Pre-test and Post-test measurements shall be compared to show pass/fail with less than 10% variance. The SPD functional indicators shall operate in the “same as new condition” with nominal AC power applied.
Part 4: Maximum Discharge Testing (see “Maximum Discharge Current Test” on page 7-58)		
Motorola Solutions Type 2A SAD/MOV and Type 2B MOV Testing At the discretion of Motorola Solutions, the Type 2B MOV testing may be judged redundant if all SPD functions and features are demonstrated under Type 2A SAD/MOV testing.		
Pre-test 10kA 8x20 μ s.	Waveforms shall be documented.	See “In Pre-test (I Nominal Current Test)” on page 7-59. Pre and Post testing per IEC 61643-1 parameters.
Maximum Discharge Calibration Short Circuit Levels: <ul style="list-style-type: none"> • 16kA 8x20 μs • 40kA 8x20 μs • 80kA 8x20 μs • 120kA 8x20 μs • 160kA 8x20 μs 	Waveforms shall be documented.	See “Imax Surge Generator Calibration” on page 7-59. Duty Cycle Calibration as per IEC 61643-1 parameters.
Type 2A/2B SPD Maximum Discharge Testing: <ul style="list-style-type: none"> • 1 strike at 16kA 8x20 μs • Followed by 1 strike at 40kA 8x20 μs • Followed by 1 strike at 80kA 8x20 μs • Followed by 1 strike at 120kA 8x20 μs • Followed by 1 strike at 160kA 8x20 μs 	Waveforms shall be documented, record the surge generator charge voltage and induced surge current for each strike, record the time between generator setup and strike execution.	See “Imax Discharge Test” on page 7-59. All tests are conducted with no AC power applied.
Post-test 10kA 8x20 μ s.	Waveforms shall be documented.	See “Pass Criteria” on page 7-60. Pre-test and Post-test measurements shall be compared to show pass/fail with less than 10% variance. The SPD functional indicators shall operate in the “same as new condition” with nominal AC power applied for 30 minutes. Thermocouples shall be applied to the top and sides of the SPD and the temperature shall be recorded to show stability.

7.14 Electromagnetic Pulse (EMP)



NOTE

The information contained in this section is courtesy of Transtector/Smiths Microwave and is for informational purposes only.

7.14.1 Referencing MIL-STD 188-125 for Commercial Applications

Electromagnetic Pulse (EMP) is an intense electromagnetic field that can instantly overload electrical circuits and damage microelectronics, electrical control and communications systems as well as electric power distribution networks. Produced in the atmosphere by the gamma ray pulse of a nuclear explosion, it is referred to as High-Altitude Electromagnetic Pulse (HEMP) or Nuclear Electromagnetic Pulse (NEMP), which affects electronic equipment over a wide area. Other sources of EMP include nuclear explosions on the ground, man-made weapons like High Power Microwave (HPM) or Directed Energy Weapons (DEW) as well as natural causes like solar storms and lightning.

The widespread, detrimental effects of an EMP/HEMP event are well understood and recognized within military theaters. To protect critical systems, the US military established a comprehensive set of standards. MIL-STD 188-125-1 and -2 in particular describe the threat environment, test methods and minimum protection requirements for HEMP hardening of fixed and transportable ground-based facilities which perform critical, time-urgent command, control, communications, computer and intelligence (C4I) functions.

Since any environmental effects of an EMP/HEMP event would also expand to the civilian infrastructure, the International Electrotechnical Commission attempted to establish a civilian set of standards resulting in IEC/TR 61000-1. While the military standard provides definitive limits for electric field shielding and pulse current injection testing, the IEC standards generally use electric system disruption as a pass fail criteria. Due to the extensive detail, highest performance requirements and credibility of the originating authority, MIL-STD 188-125 has become the most widely respected and referenced EMP/HEMP protection standard around the world. Nevertheless, proper application of this standard for non-US military applications is severely misunderstood. This paper emphasizes the purpose of MIL-STD 188-125 and explains its correct use for commercial or non-US military applications in an economically feasible way.

7.14.2 MIL-STD 188-125 – Purpose

MIL-STD 188-125-1 and -2 describe the threat environment and protection requirements for absolute critical command and control applications with no margin for disruption of command chain communications. These tests are severe and the pass requirements are conservative in the extreme. After all, this standard is intended to preserve the executive chain of command of the US armed forces. While the standards are under the responsibility of the US Defense Threat Reduction Agency (DTRA), the actual implementation falls within the governance of the US Strategic Command - operational and survivability branch of the US Armed Forces. Facilities regarded as critical command and control assets required to comply with the provisions are identified by the Joint Chiefs of Staff, Military Department Headquarters or a Major Command.

US military suppliers of equipment classified as critical per MIL-STD 188-125 have to comply with all provisions as applicable.

7.14.3 MIL-STD 188-125 – Application to Non-US Military Situations

The complexity of the provisions of MIL-STD 188-125 requires considerable investment in time and resources to understand and apply each one. Achieving full protection can quickly become an expensive endeavor. To keep financial expenses in check, many businesses and organizations referencing MIL-STD 188-125 thus consider not applying it in its entirety but attempt to extract the most important aspects. However, MIL-STD 188-125 is not a pick-and-choose menu. To effectively protect a system from EMP induced damages, the complete standard must be applied. Skipping critical shielding or filter investments could compromise the entire shelter environment.

Despite the stipulation of having to apply the standard in its entirety, it is practicable to do so in an economically feasible way. As discussed earlier, MIL-STD 188-125 is designed for facilities that perform critical, time urgent functions. This is an important aspect as it allows for scalability. For a business, the entire facility may not be critical, but instead only specific systems or servers that may fit into a room or even box. In addition, it needs to be determined whether the system needs to operate through an EMP/HEMP event or if it can accept brief disruptions as long as it can return to normal service after the event. System designers are encouraged to identify the core service or key asset that must be protected and build it into a fully compliant EMP vault at a small scale.

7.14.4 Conclusion

MIL-STD 188-125 has been designed to protect critical communications systems from HEMP damage in the most extreme environments under the most severe conditions. As such, it is an authoritative reference for any agency or organization looking to safeguard its communication structure and assets. To effectively protect a system, the standard has to be applied in its entirety. Despite its complexity, doing so can be accomplished in an economically feasible way by scaling the protection efforts down to the most critical assets of a system.

Minimizing Site Interference

This chapter provides information on preventing Radio Frequency (RF) interference at a communications site. The requirements defined in this chapter pertain to eliminating interference and are separate from the RF engineering aspects of site design. The following topics are included:

- “Interference Protection Recommendations” on page 8-1
- “General Site Environmental Requirements” on page 8-3
- “Other Band Architecture—Overview” on page 8-3
- “Mitigating External Intermodulation and TN/RD Interference” on page 8-7

This chapter describes the minimum filtering and techniques that should be applied at any fixed site to minimize interference. These techniques should be used by a site manager or carrier to define the minimum essential elements to achieve successful operation. Implementation of these requirements helps provide an environment for successful operation and future expansion.



NOTE

The requirements and recommendations in this chapter apply to both analog and digital systems.

8.1 Interference Protection Recommendations

Unlike mobile units that can be moved to an interference-free area, fixed sites must incorporate equipment and techniques to reduce the likelihood of interference. The ability to successfully receive the desired radio signal at the fixed receiver is dependent upon providing the best possible radio frequency environment at the site. To accomplish this, the level of undesirable energy occurring on the received frequency must be minimized. In most cases, minimizing the level of undesirable energy emitted by the local transmitters and filtering undesirable signals out of the receiver eliminates received interference. Interference is more likely to be a problem at sites with multiple antennas. If these measures have been taken and the receiver is still picking up noise, then noise sources in the surrounding environment must be identified and eliminated.

A successful communication site should have standards that are applied to all users of the site and recommended to other communications sites in the general vicinity. Another site within a 400 m (1/4 mile) radius may interfere with your site or may receive interference from your site unless protective equipment and techniques are used.

The techniques described in this chapter have a history of successful implementation and are not specific to any particular radio or filter vendor. The protective equipment to be used is available from numerous vendors that meet Motorola Solutions criteria for product performance, reliability and support. Contact the local Motorola Solutions Engineering team for additional details.

Transmitter noise, receiver desensitization and unwanted intermodulation caused by objects in the site environment are the most common causes of receiver interference. Other common interference terms are Co-Channel and Adjacent Channel interference. Analysis of the existing and/or proposed frequencies at an antenna site may help the site design process. Requirements for preventing problems in each of these areas are described in the following sections.

8.1.1 Minimum Transmitter Protection Requirements

A properly designed site incorporates several techniques to reduce the likelihood of the transmitters causing interference to a receiver signal. Each transmitter should have an isolator, low pass filter and bandpass cavity setup (see Figure 8-1). The number of isolators and bandpass cavities needed for a transmitter to achieve proper filtering is dependent upon the transmitter equipment and frequencies at the communication site and other transmission sites in the vicinity. If additional help is needed to determine these requirements, contact the local Motorola Solutions Engineering team for additional support.

An isolator is used on a transmitter to reduce the amount of radio energy that is allowed to enter the final amplifier stage from the antenna system. This action in turn reduces the signal levels of other undesirable radio signals entering the final amplifier stage and helps to prevent a mixing of two or more different frequencies within the non-linear device. The mixing process is called transmitter intermodulation (IM), and it can result in interfering frequencies for receivers. In some situations, the isolator can produce second harmonic spurious emissions, which are also harmful to receiver reception. To protect against this, a low pass filter should be used between the isolator stage and the antenna system.

A bandpass cavity is a high Q resonant circuit, which is designed to pass a narrow band of frequencies with very little energy loss while attenuating all other non-resonant frequencies. Bandpass cavities should be installed between the transmitter and antenna system to reduce spurious signals and transmitter sideband noise that might otherwise radiate from the transmitter and degrade the performance of nearby receivers. The use of a bandpass cavity also reduces and minimizes transmitter intermodulation, because the cavity attenuates all off-frequency signals from other nearby transmitters.

For successful operations and future expansion of the site, the following recommendations should be considered when installing transmitters within the following frequency bands. See Figure 8-1 for proper configuration of the recommended filtering devices.

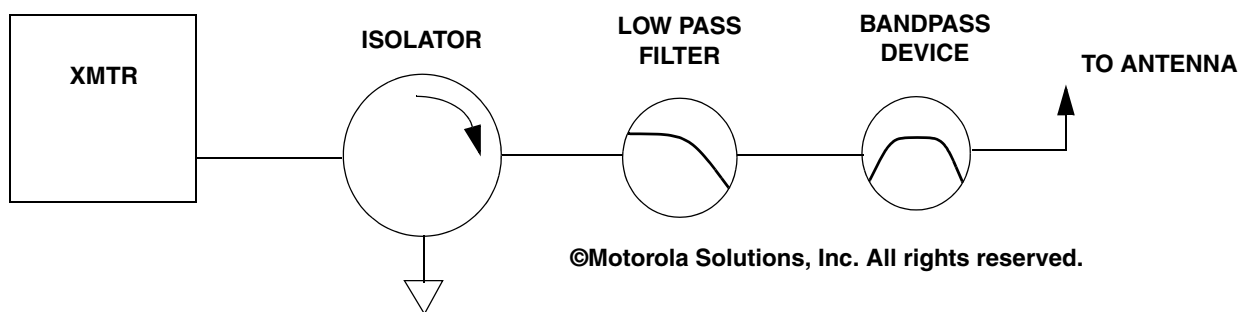

Figure 8-1 Configuration of Transmitter Filtering Device

25-54 MHz - Transmitters in this range **shall** have an isolator with a minimum of 20dB reverse isolation followed by a low pass filter and a bandpass cavity setup, which provides a minimum of 20dB of attenuation at 1 MHz from the transmit frequency.

66-88 MHz - Transmitters in this range **shall** have an isolator with a minimum of 25dB reverse isolation followed by a low pass filter and bandpass cavity setup, which provides a minimum of 20dB of attenuation at 1 MHz from the transmit frequency.

130-225 MHz - Transmitters in this range **shall** have a set of isolators with a minimum of 50dB reverse isolation followed by a low pass filter and a bandpass cavity setup, which provides a minimum of 25dB of attenuation at 1 MHz from the transmit frequency.

276-284 MHz - Transmitters in this range **shall** have a set of isolators with a minimum of 50dB reverse isolation followed by a low pass filter and a bandpass cavity setup, which provides a minimum of 25dB of attenuation at 1 MHz from the transmit frequency.

400-512 MHz - Transmitters in this range **shall** have a set of isolators with a minimum of 50dB reverse isolation followed by a low pass filter and a bandpass cavity setup, which provides a minimum of 15dB of attenuation at 1 MHz from the transmit frequency.

764-960 MHz - Transmitters in this range **shall** have a set of isolators with a minimum of 50dB reverse isolation followed by a low pass filter and a bandpass cavity setup, which provides a minimum of 15dB of attenuation at 1 MHz from the transmit frequency.

8.1.2 Minimum Receiver Protection Requirement

A properly designed fixed site requires each receiver input to be connected to a crystal filter, window filter and/or bandpass cavity to minimize or eliminate receiver desensitization (see Figure 8-2). These devices create a narrowband window to allow only the desired receive signal to enter the receiver. If the interference is very close in frequency to the receiver frequency, a dual or triple bandpass cavity setup or notch filter may be required. This is normally a less costly and more permanent option to moving the receiver antenna to an alternate location. If additional support is necessary contact the local Motorola Solutions Engineering team.

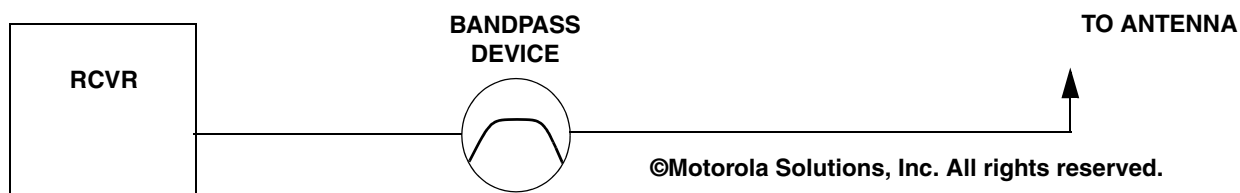

Figure 8-2 Configuration of Receiver Filtering Device

8.2 General Site Environmental Requirements

A properly designed communication site uses the following preventive measures to minimize and eliminate locations where radio signals can mix and create intermodulation frequencies or broadband noise.

- Rust: All materials must be free of rust.
- Braided wire **shall not** be used because it can corrode and cause intermodulation signals.
- Rigid metal connections: Metal to metal connections must be rigid.
- All loose metal should be removed from the site.
- Fencing: Chain link type fence material should be vinyl clad if the fence is found to be a source of interference.
- Dissimilar metals: Connection of dissimilar metals should only be made after reviewing “Dissimilar Metals and Corrosion Control” on page 4-52 (and its subsections) for each metal. The connections must be rigid and tight.
- Cable ties: Bare metallic cable ties **shall not** be used unless they are stainless steel.
- Power line insulators (glass type): Cracked insulators are a very likely source of broadband noise.

If broadband noise cannot be eliminated by implementing the recommendations in this section, contact the local utility company and ask them to perform a noise sweep of the general area.

8.3 Other Band Architecture—Overview

Some additional RF site design techniques are required to mitigate radio frequency interference for sites utilizing frequencies below 700 MHz. This is typically referred to as Other Band Architecture (OBA) and may include trunking, conventional, data, and paging systems.

With the limited number of frequencies available in the 800 MHz and 900 MHz bands, expansion into other bands is occurring. The 450 MHz and 150 MHz bands are being utilized for trunking. This utilization of older bands has introduced multi-carrier operation in bands that were originally used primarily for single carrier or limited multi-carrier. Interference obstacles within these bands require different solutions than those used at 700 MHz and above.

8.3.1 Spectrum Usage History

The 700 MHz, 800 MHz and 900 MHz frequency spectrum was coordinated to facilitate combining and trunking system design. These frequency band plans facilitate the use of multiple transmitters connected to a single antenna, as well as receivers connected to a single receive antenna. This allows for the use of standard combining and multicoupling schemes. These bands are divided by a defined spacing between the transmit and receive channel pairs (45 MHz for 800 MHz, 39 MHz for 900 MHz and 30 MHz for 700 MHz). This spacing helps isolate the intermodulation interference that occurs when two or more frequencies mix in non-linear devices, producing carriers on the existing receiver frequencies.

The VHF and UHF bands were not organized with the same standards as the 700 MHz, 800 MHz and 900 MHz bands. Therefore standard combining and multicoupling schemes cannot be utilized and extensive frequency planning must occur during system design. These items may add significant design time and cost to a project. The UHF and VHF frequency bands have far less immunity to interference because the spacing between transmit and receive channels is not a defined constant. The result can be catastrophic interference if systems are not properly designed. Interference will affect sites with OBA systems if not properly addressed.

8.3.2 Forms of Interference

Interference can have many sources. All forms of interference must be monitored regularly for reliable communication. Interference is normally classified as internal or external. Internal interference is generated within the components of the system. External interference is generated externally and radiates into the affected system. Internal interference can be prevented with good radio system design practices. All external interference must be eliminated at the source.

Examples of interference include internal and external intermodulation (IM), transmitter sideband noise (TN), receiver desensitization (RD), co-channel interference and passive intermodulation (PIM). These are briefly described as follows.

- **IM:** normally caused locally within the system or on-site. This form of interference is caused by the mixing of multiple transmitters producing an on frequency carrier.
 - Internal IM is generated within system components. This can occur within the transmitter power amplifier, within the transmitter combining isolator and within the receiver when strong off-frequency signals are allowed to enter the front end of the receiver and mix.
 - External IM is generated external to the transmitter or receiver system components. This interference can be produced in non-linear components on the site. Rusty tower joints, rusty fences, guy wires, corroded connectors and inadequate grounding can also be sources of intermodulation. In all cases the only solution for external intermodulation is to find the source and eliminate it.
- **Transmitter Sideband Noise:** All transmitters emit some noise. Transmitters should have bandpass filtering added to reduce this noise and protect collocated receivers (see Figure 8-1).
- **Receiver Desensitization:** A receiver's ability to process weaker signals is reduced by the influence of a strong signal occurring on a closely spaced channel. Unlike the other types of interference, there are no audible indications of interference; there is only a reduction in receiver sensitivity.
- **Co-channel:** Multiple transmitters within the same coverage area assigned the same frequency.
- **Adjacent Channel:** Interference from users on a frequency assignment next to the operating frequency.
- **PIM:** Another type of intermodulation, evident in passive system components. Common mixing points are connectors, cables, surge protective devices, combiners and antennas. Use of high quality (PIM rated) components can mitigate these issues.

8.3.3 OBA Interference Mitigation

When designing a new system utilizing OBA frequencies the following items should be considered and practiced:

- Document Frequency Layout
- Create Band Plan (Specific Tx/Rx Pairs)
- Perform Intermodulation Analysis
- Perform TN/RD Analysis

- Antenna Network Components PIM analysis and PIM sourcing
- Optimization/Testing
- RF Maintenance

Each of these items is discussed in more detail in the following subsections.

8.3.3.1 Document Frequency Layout

All available frequencies that may be used, as well as those already in use, should be defined and documented. A thorough “frequency inventory” consisting of the following activities should be performed:

- Collect/search for available frequencies.
- Conduct site audits of existing frequencies used on-site.
- Document existing user antenna locations as an aid in the antenna/combining design.

8.3.3.2 Create Band Plan

After all frequencies have been identified, create a band plan for specific transmit/receive pairs. The following tasks should be performed:

- Arrange frequencies in contiguous transmit and receive blocks to create guard bands.
- Create the band plan (specific transmit/receive pairs).
- Minimize implicit band plan elements used for system expansion (maximum of 16 elements).
- Maximize guard bands between transmit frequency blocks and receive frequency blocks.
- Maximize transmit/receive frequency separation for each channel to help control combining size and cost.
- Assign channel pairs to sites.
- Avoid narrow separations from existing frequencies on-site whenever practicable. This helps keep combining size/cost down.

8.3.3.3 Perform Intermodulation Analysis

Intermodulation (IM) products are generated whenever two or more frequencies mix together at a radio site. Under the worst adverse conditions, the reception of the desired on-channel frequency can be suppressed by the FM capture effect of stronger undesired IM products. If the intensity of the IM product is lower than that of the desired signal it may still cause audible interference. In a digital system, undesired IM products may result in an increase in Bit-error Rate (BER) of the desired signal. This increase in BER can result in “digital artifacts” in the recovered audio and in severe cases a complete loss of audio.

An IM study can help detect interference products and the root frequencies that can mix to cause interference. Motorola Solutions Engineering can perform the intermodulation analysis. The following guidelines apply when working with the IM analysis results:

- Run third, fifth and seventh order IM.
- Determine PIM risk and design.
- Avoid third-order IM within a single combiner.
- Avoid third-order IM on-site or tower if possible.
- Avoid fifth- or seventh-order IM within combiner.

8.3.3.4 Perform Transmitter Noise / Receiver Desense Analysis

Systems affected by Transmitter Noise/Receiver Desense (TN/RD) conditions show signs of reduced radio coverage. A TN/RD analysis can provide the information needed to determine existing or planned two-way radio systems that have the potential to cause interference. This knowledge will help systems engineers select equipment needed to correct or prevent interference.

Motorola Solutions Engineering can perform the TN/RD analysis. The following guidelines apply when working with the TN/RD analysis results:

- Design for all frequencies on-site, not just customer frequencies.
- Transmitter Combiner Network:
 - 45 dB minimum selectivity at each Guard Band plus 45 dB minimum transmit-to-receive antenna isolation (90 dB total)
 - Insertion loss balanced within 4.5 dB across ports
 - 6 channel ports or fewer on each combiner
 - 90-100 kHz minimum Tx-to-Tx frequency separation
 - Install second Tx antenna to mitigate third-order IM
 - Use greater vertical separation between transmit and receive antennas to mitigate fifth- and seventh-order IM risk. 6 vertical meters (20 vertical feet) provides 55 dB isolation.
- Receiver Multicoupler Network:
 - 65 dB minimum selectivity at each Guard Band plus 45 dB minimum transmit-to-receive antenna isolation (110 dB total)
 - 15 dB reserve gain available
 - 45 dB third-order Intercept Point in Amplifier
 - < 2 dB noise figure in Amplifier
 - Use greater vertical separation between transmit and receive antennas to mitigate fifth- and seventh-order IM risk. 6 vertical meters (20 vertical feet) provides 55 dB isolation.

8.3.4 Antenna Network Components

Follow these best practices during design when selecting antenna network components:

- Always use Passive Intermodulation (PIM) rated components, including antennas, connectors, surge protective devices and combiners with PIM specifications.
- Use 7-16 DIN connectors (PIM rated) on all transmit network components.
- Superflex cable from combiner output to transmit antennas **shall not** be used.
- Follow mounting recommendations:
 - Try to mount transmit antennas on top of tower.
 - Mount transmit antennas as far apart as practicable.
 - Mount transmit antennas on different mounting structures.
 - Mount antennas as far from tower as practicable.
 - Mount the receive antenna as far from the transmit antenna as practicable.
- Use proper torque on all connectors according to manufacturer specifications. See “Torque” on page 9-57.
- Cables should be continuous with as few connections, jumpers and adapters as practicable.
- Clean all connections before assembly/re-assembly. See “RF Connectors” on page 9-55.

8.3.5 Optimization and Testing

When installing a new system, the following should be performed and documented:

- Measure Effective Receiver Sensitivity (ERS) on the receivers.
- Measure TN/RD degradation from **all** transmitters on-site.

- Perform Frequency Domain Reflectometer (FDR) testing on antenna systems, verifying all installed components meet the manufacturer's specifications. See “Antenna System Analysis (Antenna System Commissioning)” on page 9-58.

8.3.6 Maintenance

Throughout the life of a system, the following should be considered for system maintenance:

- Frequency changes should be considered a redesign.
- Frequency additions to site must be monitored.
- Interference degradation must be monitored with periodic effective receiver sensitivity (ERS) tests.
- Perform periodic Frequency Domain Reflectometer (FDR) testing on antenna systems, verifying the antenna system has not degraded from original installation testing (commissioning).

8.4 Mitigating External Intermodulation and TN/RD Interference

Motorola Solutions provides some general guidelines to mitigate the effects of interference caused by intermodulation and TN/RD from the existing user community. Guidelines are provided in the following subsections for each type of external interference. Motorola Solutions Engineering can assist in mitigation of external IM and TN/RD interference problems.

In most cases, minimizing the level of undesirable energy emitted by the local transmitters and filtering out undesirable signals coming into the receiver eliminates received interference in the receiver environment. Interference is more likely to be a problem at sites with multiple antennas.

8.4.1 Intermodulation

Every transmitter on-site **shall** be equipped with a dual-stage isolator with second harmonic filter or bandpass cavity on the isolator output. Strong IM can be generated from the transmitter power amplifier (PA). The dual-stage isolator greatly reduces the amount of external frequency energy entering a transmitter PA and consequently, the level of IM generated. The radio site must be clear of any dissimilar metal connections, rusty metallic areas, rusty fence bolts, rusty building and tower bolts, loose guy wires, and so on. Many of the R56 site improvements are helpful to reduce or eliminate these sources where multiple frequencies mix to produce intermodulation products. Jacketed hardline transmission lines (with solid shield) and type N connectors **shall** be used instead of RG-8 (or equivalent) cable and UHF connectors. Where two or more transmit frequencies are combined to one antenna, connectors **shall** be 7-16 DIN connectors. Type N connectors have been found to be a mixing point source of IM products.

Every receiver should have a band pass cavity to prevent strong transmitter signals from swamping the receiver, then mixing to form IM products that are generated from a base station's receiver. Transmit antenna and receive antenna isolation is helpful to prevent harmful interference from IM products. A good rule of thumb is to have a transmit to receive antenna isolation of at least 45 dB. This is achieved by mounting the tip of the lower antenna 3 m (10 ft) vertically below the base of the upper antenna. The idea is to reduce the level of IM reaching any given receiver. Because tower space is limited, the best way to achieve this for all users on-site is to develop a master combining system where the receive antenna(s) occupy a defined receive-only zone on the tower, while transmit antenna(s) occupy a defined transmit-only zone. The receive and transmit antennas are separated by at least 3 vertical meters (10 vertical feet) to provide 45 dB of isolation. The more vertical separation between transmit and receive antenna, the better the isolation obtained. For example, 6 m (20 ft) of vertical separation provides 55 dB of antenna isolation.

8.4.2 Transmitter Noise/Receiver Desense (TN/RD)

All transmitters on-site should have sufficient transmitter noise filtering to reduce harmful on-channel noise to all receivers on-site. This is best achieved through a bandpass cavity that reduces the on-channel transmitter noise below the interference level (see Figure 8-1). Transmitter noise problems are on-channel to a receiver frequency, therefore, transmitter noise problems must be addressed at the source. A good rule of thumb is for each transmitter to reduce its sideband noise by approximately 90 dB. This number varies depending on the particular base station model and make. If transmit antennas are spaced at least 3 vertical meters (10 vertical feet) from receive antennas, this means only 45 dB of transmit noise bandpass cavity suppression is needed, as the antenna separation achieves 45 dB isolation.

All receivers should have bandpass cavities to prevent receivers from being desensitized by nearby strong transmit frequency carriers (see Figure 8-2). A good rule of thumb is to provide sufficient filtering to the 110 dB level. This number will vary depending on the model and make of the base station. Receive antenna to transmit antenna isolation of at least 45 dB, achieved by 3 m (10 ft) of vertical separation, is recommended. This reduces the amount of receiver band pass cavity filtering required by 65 dB. Because tower space is limited, the best way to achieve this for all users on-site is to develop a master combining system where the receive antenna(s) occupy a defined receive-only zone on the tower, while transmit antenna(s) occupy a defined transmit-only zone. The receive and transmit antennas are separated by at least 3 vertical meters (10 vertical feet) to provide 45 dB of isolation. For example, 6 m (20 ft) of vertical separation provides 55 dB of antenna isolation.

8.4.3 Simplex Multi-Frequency Stations

Simplex multi-frequency stations cannot be combined or even have cavities installed on them. Because cavity filters are tuned to operate at one frequency, they cannot be used on multi-frequency stations. These types of stations must be evaluated carefully on a case by case basis because there is little that can be done to mitigate any interference involving them.

Equipment Installation

This chapter describes requirements and standard methods for communications equipment installation. This chapter includes the following topics:

- “General Installation Considerations” on page 9-4
- “Facility Readiness” on page 9-4
- “General Considerations for Layout, Work Areas and Spacing” on page 9-5
- “Seismic Considerations” on page 9-9
- “Level, Plumb and Squareness” on page 9-16
- “Equipment Anchoring” on page 9-17
- “Equipment Installation Within Racks or Cabinets” on page 9-22
- “Ancillary Equipment Mounting” on page 9-23
- “Equipment Cabling” on page 9-23
- “Tower Lighting Systems” on page 9-65
- “Equipment Removal” on page 9-65
- “Site Security Surveillance Systems” on page 9-67
- “Utility Pole-Mounted Equipment Installation and Clearances” on page 9-68

9.1 Introduction to Equipment Installation

Today's public safety communications, E911 and data systems provide more features and more functionality than ever before. Computers and computer networking technology provide more mission critical flexibility. However, computers, computer based equipment and networks provide unique challenges in order to ensure safe and reliable operation. This is especially true in a public safety environment.

The proper installation of equipment is critical not only to optimal functioning of the communications system, but also to the safety of installation, maintenance and dispatch personnel. In order to maximize equipment availability, reliability and safety, good installation practices must be followed.



NOTE

The requirements described in “Facility Readiness” on page 9-4 **shall** be met before communications equipment is installed at a site.



NOTE

This chapter assumes that all site and structure preparations have been performed (including battery systems, generators, line transient voltage suppression systems, tower systems and site/structure grounding systems).

All building construction or alterations **shall** be completed before the start of the installation activity. The site **shall** provide a reasonably waterproof and dust free environment within the installation activity area. (Telcordia GR-1275 issue 3 2.4.)

9.1.1 Safety for Equipment Installation

The safety requirements and suggestions in this section **shall not** be interpreted as a complete list of safety requirements. The installer **shall** be responsible for providing a safe working environment and complying with applicable national and local safety codes, including Occupational Safety and Health Administration (OSHA) (or equivalent) and local safety rules, regulations and codes.

9.1.1.1 General Safety Requirements

The following is a list of general safety requirements:

- All site preparation, installation, maintenance and removal activities **shall** be performed by properly trained and qualified personnel.
- The Project Manager **shall** be responsible for properly supervising project team members and **shall** ensure that they are complying with the requirements of this manual.
- All manufacturers' instructions regarding safety **shall** be adhered to.
- All required safety items **shall** be on site and readily accessible while work is in progress.
- All safety hazards discovered on site **shall** be noted and brought to the attention of the site owner and/or Project Manager.
- Eye and face protection **shall** be worn when workers are exposed to eye or face hazards such as flying objects, molten metal, liquid chemicals, acids or caustic liquids, chemical gases or vapors, or potentially injurious light radiation (OSHA 29 CFR 1910.133).
- Ear protection **shall** be worn while operating or working near power tools or machinery that requires the use of hearing protection (for example, running diesel or turbine engines, hammer drills, and so on).
- A dust mask or other appropriate respirator **shall** be worn as required to protect workers from inhaling hazardous particulates and/or contaminants (see OSHA 29 CFR 1910.134).
- Hard hats **shall** be worn any time work is being performed overhead and when required by federal, state or local regulations.
- Proper safety procedures and precautions **shall** be followed when scaffolds or ladders are used. See Telcordia GR 1275 issue 3 - section 4.3, for more information.



IMPORTANT

Prior to the commencement of project activities, the Motorola Solutions Project Manager shall convene a safety meeting for all project personnel.

9.1.1.2 Fire Safety

The following are the general fire safety guidelines and requirements:

- All applicable federal, state and local codes pertaining to fire safety **shall** be adhered to.
- Halls, stairs, passageways, fire exits and space surrounding fire alarm boxes, fire-fighting equipment, fuse boxes and AC cabinets **shall not** be obstructed in any way.
- Installer employees **shall** be made aware of the location of fire-fighting equipment, including portable fire extinguishers, during construction and installation.
- All trash and packing materials **shall** be removed daily.
- Combustible materials **shall not** be stored near heat producing equipment (for example, indoor generators, stovepipes, flues or uncovered steam pipes).
- Flammable materials **shall not** be used for building or equipment protection.
- Materials such as fire-retardant hardboard or metal **shall** be used to protect the flooring when moving heavy equipment or cable into and out of a work area. These materials **shall** be removed from the site after use.

- Protective coverings around working equipment **shall** be made of fire-retardant and electrostatic discharge (ESD)-resistant material.
- All cable penetrations **shall** be closed as soon as practicable but no later than the end of each working shift.
- Fire doors **shall not** be propped open or obstructed from closing at any time or in any manner.
- See “Fire Protection and Safety” on page 3-20 for more information.

9.1.1.3 Hazardous Materials

All activities are required to be in full compliance with all applicable federal, state and local laws that are designed to protect human health and the environment including, but not limited to, those laws regulating the handling, packaging, storage, transportation, and disposal or recycling of toxic and hazardous materials.

- Where applicable, a Material Safety Data Sheet (MSDS) **shall** be available on site.
- The Project Manager **shall** ensure all personnel working on site are informed regarding any potentially hazardous materials.
- The Project Manager **shall** make periodic inspections to identify and clear any hazardous or potentially hazardous conditions created by the installation/removal activities.

9.1.2 Installation Practices

To help ensure a safe and quality installation, the following installation practices **shall** be observed.

- Tools **shall** be used only for their intended purpose.
- Tools **shall** be the appropriate type and size for the job and be in good repair (Telcordia GR 1275 issue 3 - section 7).
- When using tools, the manufacturer's instructions for application, adjustment and use **shall** be strictly adhered to (Telcordia GR 1275 issue 3 - section 8).
- When applicable, all measuring or testing equipment and tools **shall** contain calibration stickers indicating when the next calibration is due and when the equipment was last calibrated (Telcordia GR 1275 issue 3 - section 8).
- Low AC and DC voltages (less than 60 volts) are not normally considered as hazardous as high voltages, but can still cause serious injury or death. The Installer **shall** use tools insulated by the tool manufacturer and protective materials to prevent accidental shorts. It is recommended that rubber floor mats be used for personal protection from electrical shock while performing work on or near exposed live equipment (Telcordia GR 1275 issue 3 - section 17).
- The installer **shall** remove all exposed metallic items, such as rings, watches, dangling keys, jewelry, and so on, during all job activities in the area of power equipment and batteries (Telcordia GR 1275 issue 3 - section 17).
- Metal measuring tapes **shall not** be used in areas with exposed live conductors or circuits (Telcordia GR 1275 issue 3 - section 17).
- Walkways, aisles, entrances and exits **shall** be kept clear of tools, equipment and debris (Telcordia GR 1275 issue 3 - section 4).
- Personnel **shall not** walk or stand on cable trays, raised floor stringers, straps, panning, ducts, cables, wires or optical fiber cable/jumpers.
- Holes in floors or ceilings created for cable penetrations **shall** be sealed to prevent items falling through to the surface below.
- Holes in the floor due to the removal of equipment **shall** be properly sealed.
- Floors **shall** be free of excess installation materials such as screws, wire trimmings, metal shavings from drilling, and so on.

9.2 General Installation Considerations

- Cable trays, equipment racks, cabinets and braces **shall not** obstruct lighting, smoke detectors, HVAC ducts, circuit breaker panels, and so on.
- Bolts, nuts and screws **shall** be tightened and torqued to manufacturer's specifications. Fastening hardware **shall not** be so tight as to distort any part.
- The threads on bolts, screws, rods and similar fastening devices **shall** be engaged through to the final thread of the fastening device.
- Cut ends of cable trays, racks, equipment frames, and so on **shall** have all sharp edges and burrs removed. The cut ends of surfaces **shall** be painted.
- Exposed ends of threaded rods **shall** be capped.
- When drilling concrete or masonry in equipment rooms, it is recommended that the concrete dust be continually vacuumed during the drilling process (for example, hold the vacuum nozzle adjacent to the hole being drilled).

9.3 Facility Readiness

Following all construction work, both exterior and interior, the site and facility (structure or shelter) **shall** be in a suitable condition for installation of communication equipment. The following must be complete prior to communication equipment installation:

- Shelter exterior **shall** have final backfill and grade.
- Path between shelter and access road **shall** be free of trackable debris.
- Interior of facility **shall** be free of excessive dust or debris.
- Site exterior area **shall** have all refuse related to the installation tasks removed before occupancy.
- Building construction or alterations affecting the equipment installation area **shall** be completed before the start of the installation activity.
- The site **shall** provide a reasonably waterproof environment within the equipment installation area (Telcordia GR-1275 issue 3).
- Equipment entering the equipment room or shelter **shall** be free of dust, dirt and foreign substances.
- Equipment **shall** be protected from dirt, dust and debris during installation, removal, maintenance and construction activities. If equipment is to be covered or wrapped, appropriate anti-static material **shall** be used. If a protective barrier is constructed, any heavy gauge plastic material may be used, provided the material does not come into contact with the equipment.
- Cleaning methods **shall** generate minimal amounts of airborne dust. Vacuum cleaners should be equipped with High Efficiency Particulate Arrestor (HEPA) filters.
- Materials that may cause an Electrostatic Discharge (ESD) condition **shall not** come into contact with the equipment or be stored in the equipment room. Some examples of these materials include plastics and polystyrene.
- All federal, state and local laws, ordinances, regulations and codes (building, fire, and so on) **shall** be adhered to during the course of an installation, removal, maintenance or construction.
- Should any federal, state or local law, ordinance, regulation or code conflict with any of the requirement in this manual, the installer **shall** identify this conflict and contact the site owner and/or project manager for resolution.

9.3.1 Installations at Existing Sites

Installing equipment into existing sites can pose significant challenges. All sites **shall** conform to the requirements and guidelines set forth in this manual except where the facility was built prior to the publication of this edition of the manual. In that case, the site **shall** minimally conform to the edition of this Standards and Guidelines for Communications Sites manual that was effective at the time the facility was built. New installations in an existing site **shall** conform to the most current version of this manual.

Existing facilities **shall** be maintained in accordance with the applicable regulations, requirements and specifications of the following regulations:

- NFPA 70 (National Electrical Code®)
- Occupational Safety and Health Act (OSHA)
- Federal, state and local codes as enforced by the Authority Having Jurisdiction (AHJ).

9.4 General Considerations for Layout, Work Areas and Spacing

In order to allow for adequate equipment maintenance and personnel safety, equipment spacing guidelines **shall** be followed. When laying out a site, consider all code requirements for spacing and for the most efficient use of space. Special attention **shall** be given to future expansion with regard to cable runway heights, electrical outlet placement and equipment placement.

9.4.1 Spacing Requirements

Proper spacing of equipment is essential for efficient use of the room area, ease of maintenance and safety of personnel. The following specifications have been established to meet NFPA® codes and the American Society of Heating, Refrigerating and Air Conditioning Engineers (ASHRAE) standards. Any local regulations, as applicable, **shall** also be followed.



NOTE

By Special permission from the Authority Having Jurisdiction, smaller working spaces **shall** be permitted where all exposed live parts operate at not greater than 30 volts rms, 42 volts peak or 60 VDC.



IMPORTANT

Communications equipment shall not be installed within the required clear working space of an electrical panelboard. The required clear working space shall remain free of debris and shall not be used for storage. For equipment operating above 150 V to ground, consult NFPA 70-2017, Article 110.26, for spacing requirements.

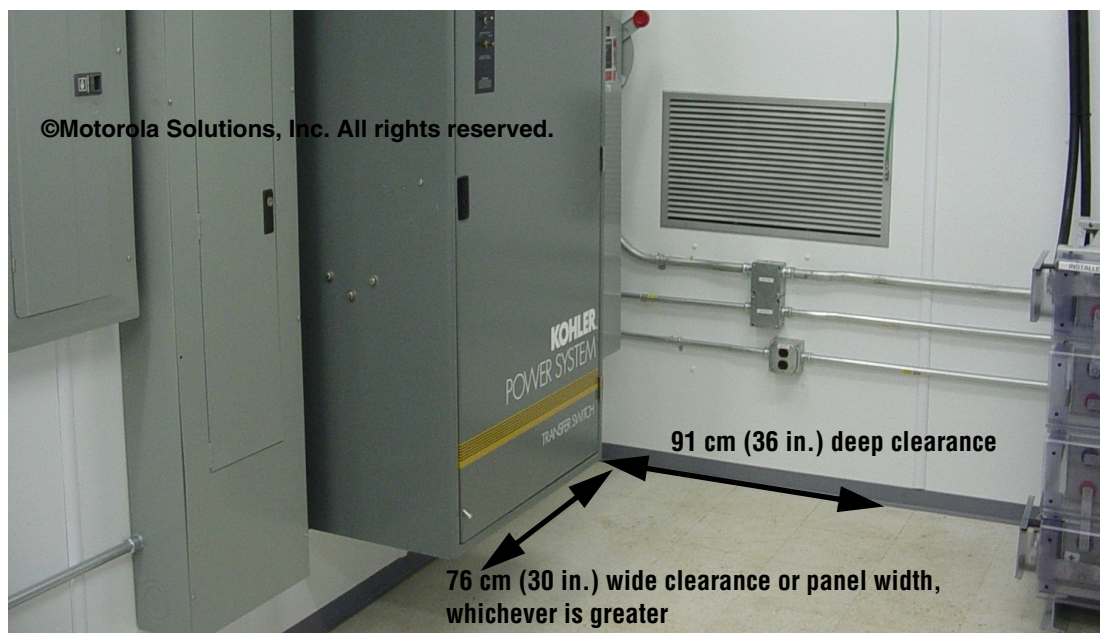

Figure 9-1 Example of Equipment Spacing

9.4.1.1 Spacing Requirements for Electrical Power Equipment (AC or DC)

- A clear working space **shall** be provided around all electrical panelboards and/or DC power plants.
- The minimum width of the working space **shall** be the width of the panelboard(s) or 762 mm (30 in.), whichever is greater, and permit opening of any doors or hinged panels to 90° (NFPA 70-2017, Article 110.26). See Figure 9-2. The same requirements apply to DC power plants, batteries and uninterruptible power systems (UPS).

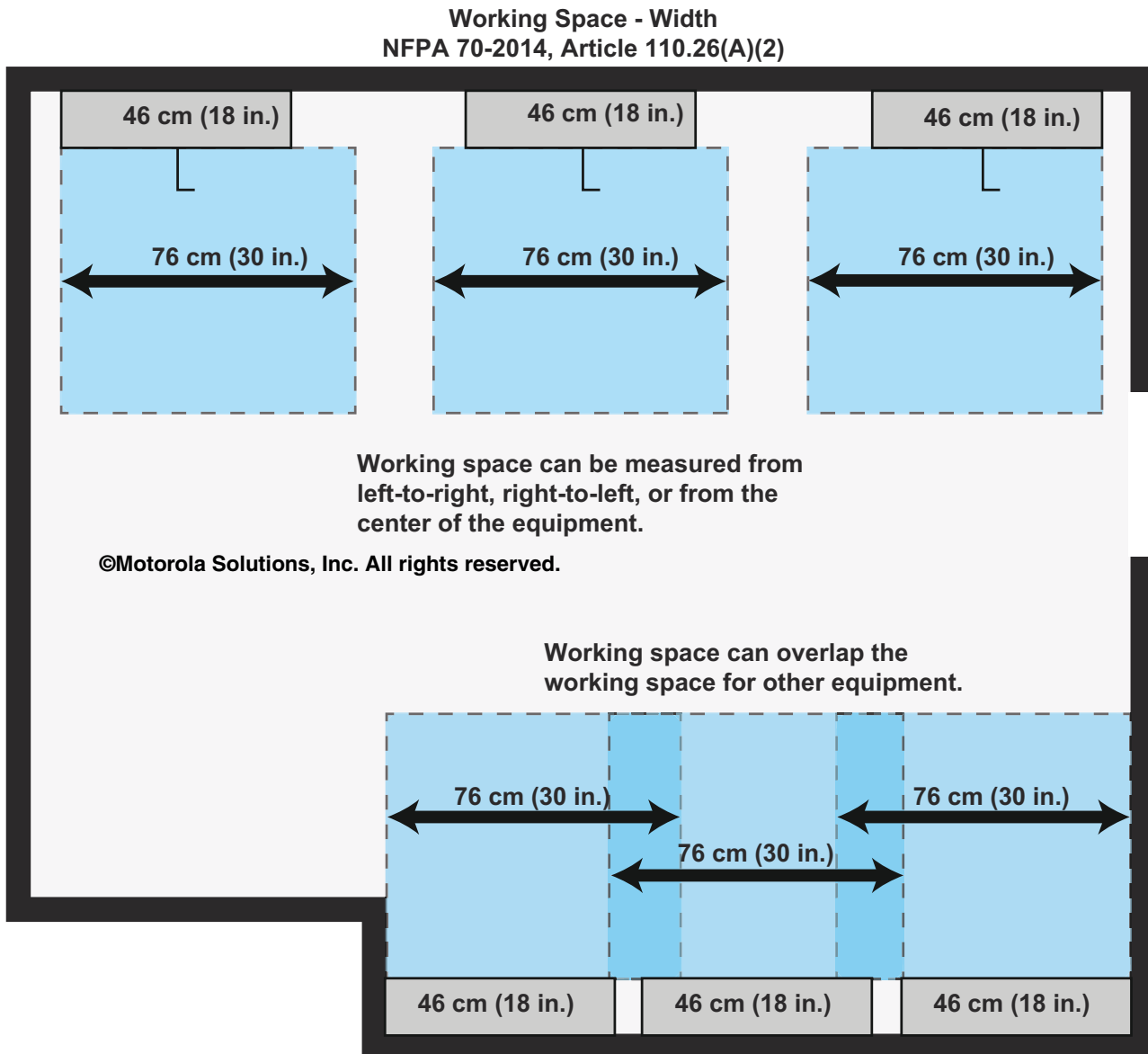

Figure 9-2 Width of Work Space

- The work space **shall** be clear and extend from the grade, floor or platform to a height of 2.0 m (6.5 ft) or the height of the equipment, whichever is greater. Other equipment that is associated with the electrical installation and is located above or below the electrical equipment **shall** be permitted to extend not more than 150 mm (6 in.) beyond the front of the electrical equipment. See Figure 9-3.

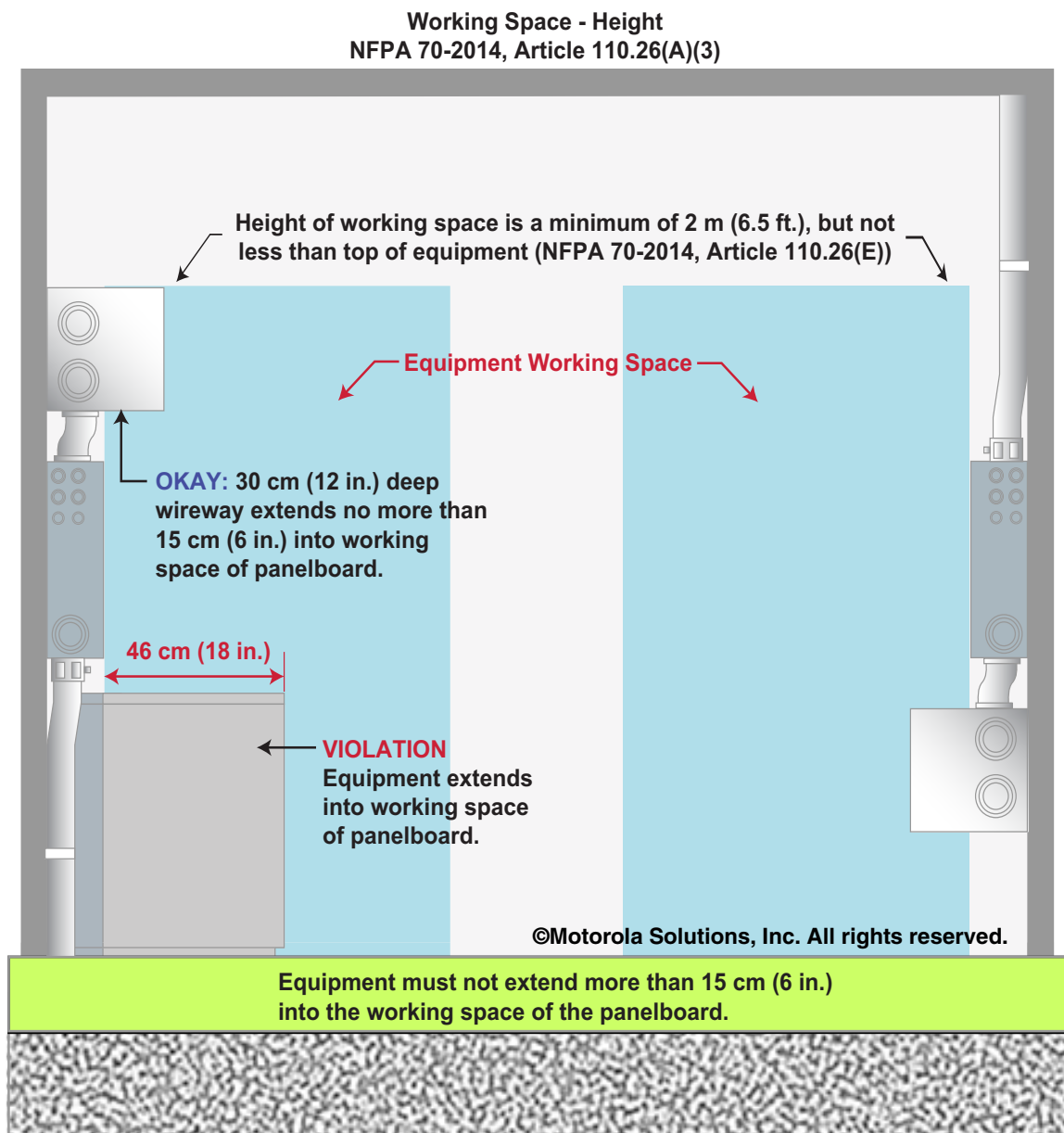

Figure 9-3 Height of Work Area

9.4.1.2 Spacing Requirements for Other Equipment

- Aisles of 914 mm to 1.2 m (36 to 48 in. in width) **shall** be required at front, side and (where applicable) rear for servicing interior mounted air conditioners (NFPA 70-2017, Article 110.26, ASHRAE).
- A 762 mm (30 in.) aisle **shall** be maintained in front of all telephone switching equipment and/or demarcation cabling (NFPA 70-2017, Article 110.72).
- A 914 mm (36 in.) aisle **shall** be maintained in situations where there is telephone switching equipment and/or demarcation cabling on both sides of the aisle (NFPA 70-2017, Article 110.72).
- A 762 mm (30 in.) minimum workspace **shall** be maintained on all non-egress or aisle ways. See Figure 9-4.

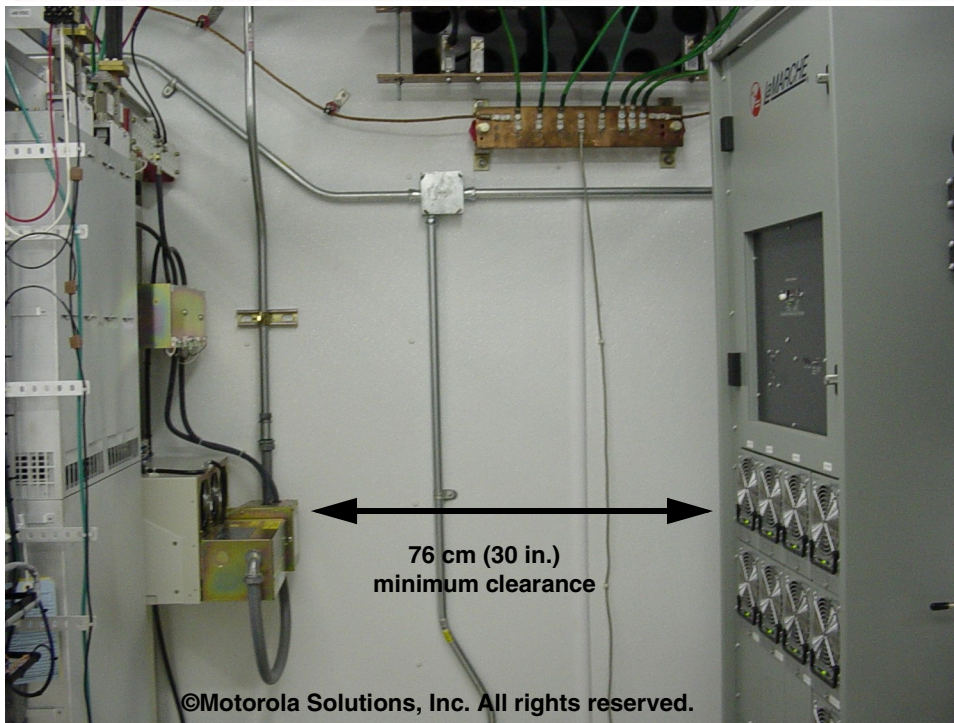
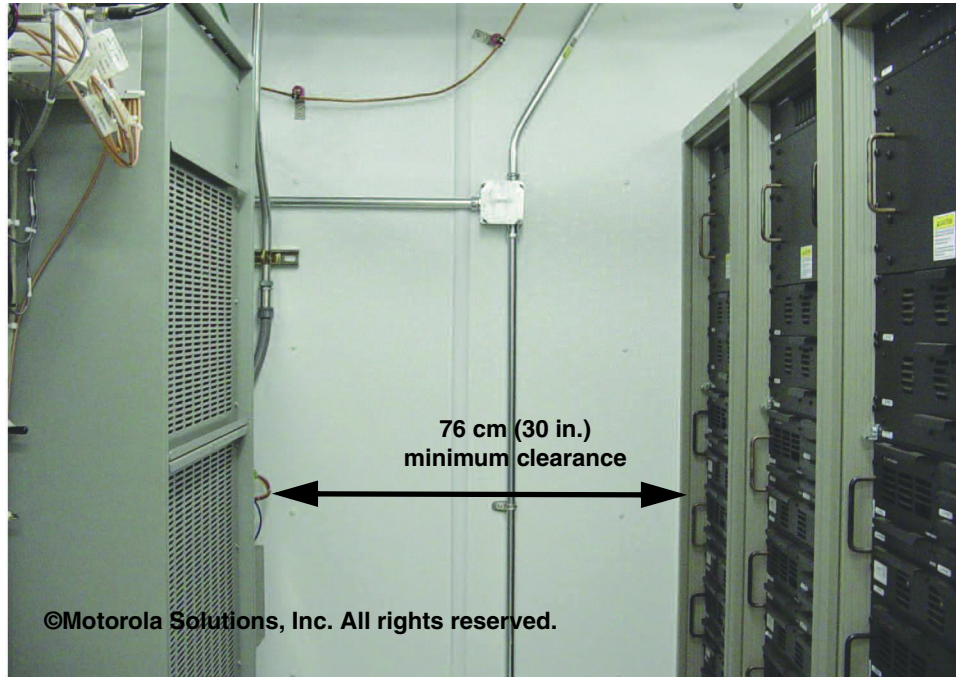

Figure 9-4 Examples of Aisle Width



NOTE

Base stations and other equipment designed for front service access only and/or wall mounting do not require working space at the rear of the equipment. Equipment requiring rear access for servicing **shall** have a 762 mm (30 in.) minimum workspace at the rear of the equipment.

- A 914 mm (36 in.) aisle **shall** be maintained between at least one end of an equipment row and building wall or other obstruction; longer aisles may require additional access breaks. Larger aisles and additional access breaks in a row may be required as the row becomes longer, such that a fire in the aisle does not prevent egress. Comply with local codes regarding fire egress specifications. See Figure 9-5.

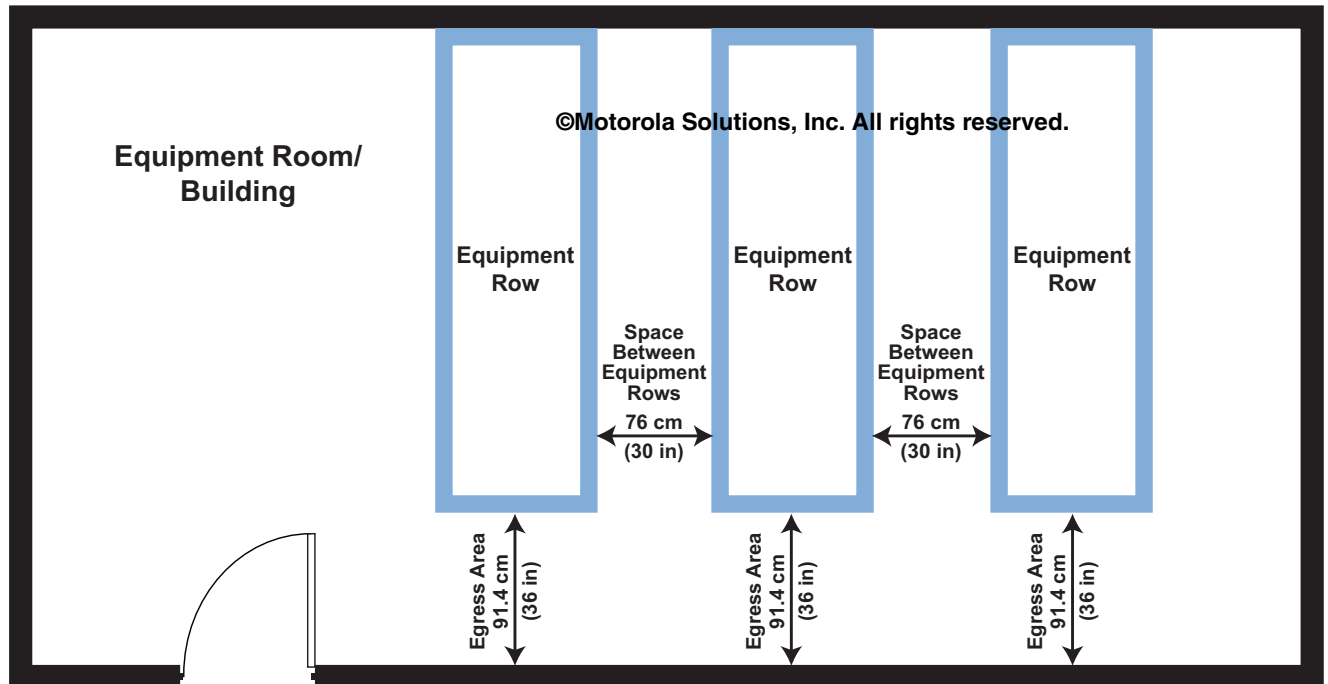

Figure 9-5 Example of Equipment Layout

- Ingress and egress to equipment rooms **shall** conform to NFPA 70-2017 Article 110 and local building and fire codes.
- US installations at facilities that are normally occupied **shall** comply with access requirements of the Americans with Disabilities Act (ADA). General requirements of ADA include 914 mm (36 in.) wide doors; ramps and safety rails; 914 mm (36 in.) minimum turn-around clearance for wheelchairs, and specific placement of telephones, fire extinguishers, light switches, and so on. Note that ADA compliance in architectural plans may be required in obtaining a construction permit in some localities.



NOTE

Local codes may require clearance in addition to those stated in this section. In such cases, the local code **shall** prevail.

9.5 Seismic Considerations

In seismically active areas, special equipment installation techniques may be required. Typically, this includes areas in seismic zones 1 through 4 (see Figure 9-6). These techniques are critical in order to help ensure system availability during a seismic event. Areas other than historically prone areas may need consideration as well. No requirements are provided for Zone 0 because Zone 0 presents no substantial earthquake risk.

During an earthquake, equipment is subjected to motions that can over-stress equipment framework, circuit boards, cabling and connectors. The amount of motion and resulting stress depends on the structural characteristics of the building and framework in which the equipment is contained, as well as the severity of the earthquake.



NOTE

Consultation with the Authority Having Jurisdiction (AHJ) for specific requirements is recommended.

A licensed (registered) architect specializing in earthquake-resistant installation **shall** be consulted for seismic designs and recommendations in areas where the potential loss of the site may outweigh associated costs of earthquake-resistant design. In the United States, it is recommended to consult the US Geological Survey for additional information regarding earthquake probability and historical data for various areas. In other areas, similar consultation should be done.

For Mission Critical Equipment, seismic anchorage and provisions should be included to assure high availability and reliability of the equipment regardless of the seismic design category of the data communication center.

US Geological Survey information can be accessed at <http://geohazards.cr.usgs.gov>.

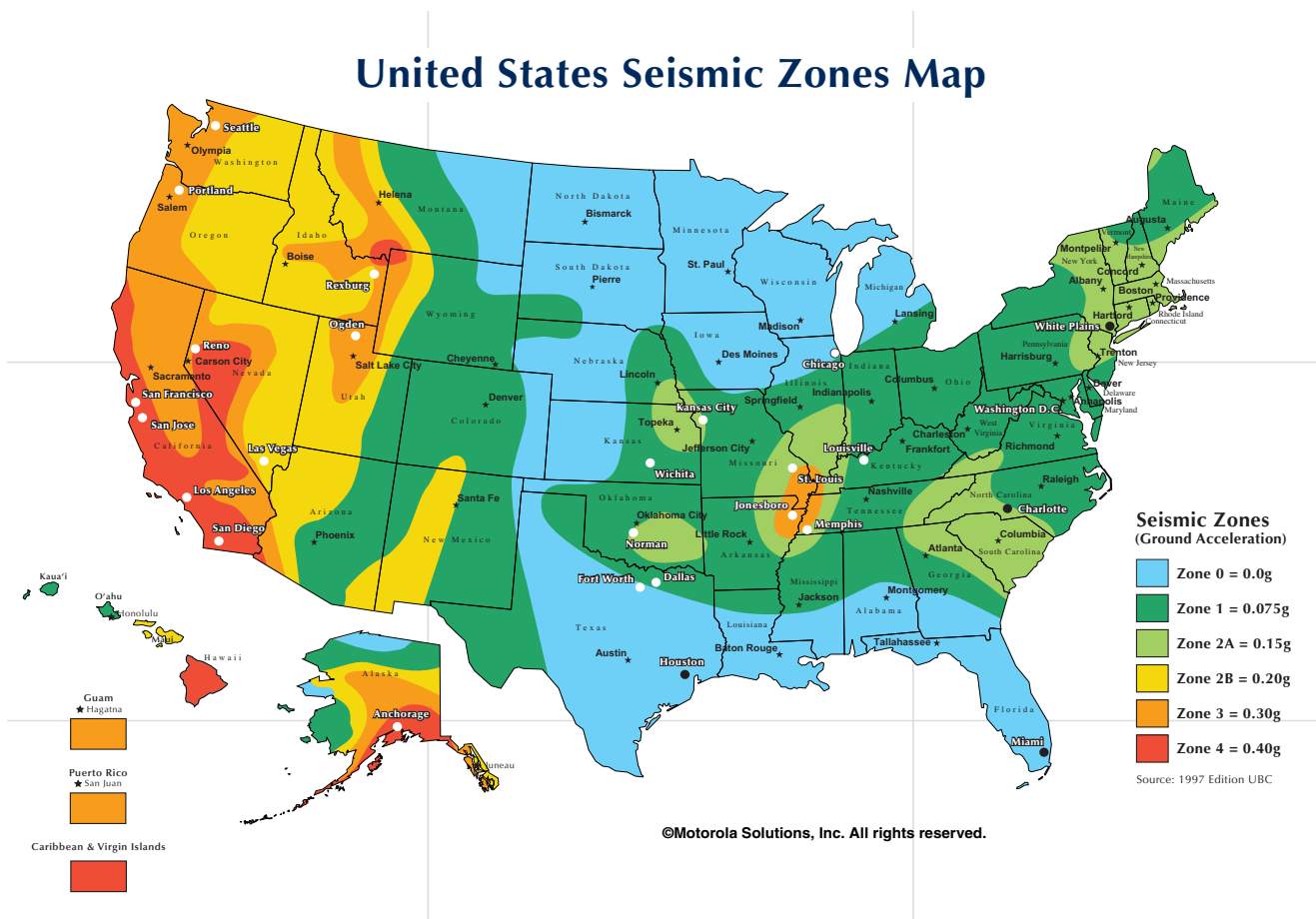

Figure 9-6 United States Seismic Zones

9.5.1 Seismic Requirements and Recommendations

Refer to the following sections for seismic requirements and recommendations for communication sites.

9.5.1.1 Concrete Anchors

- Concrete anchors **shall** meet the performance requirements of Telcordia[®] NEBS[™] Requirements GR-63-CORE-2006.
- Concrete anchors used to base mount the framework to the floor should be suitable for earthquake (dynamic) applications, as specified by the manufacturer (GR-63-CORE-2006).

- Concrete expansion anchors should use steel construction to minimize creep (GR-63-CORE-2006).

**CAUTION**

Before drilling into concrete floors, contact the building engineer and/or site owner to determine floor construction (for example, prestressed concrete, and so on). If engineering as-built drawings are not available for the site, X-rays of the area to be drilled for the anchors are required to determine the location of structural components and rebar.

**NOTE**

Typical concrete anchors are not designed for dynamic loads, such as earthquakes. The criterion referenced in this section specifies that the selected anchors should be designed to meet the dynamic loads specified in this document (GR-63-CORE-2006).

9.5.1.2 Other Anchors

- Anchors (such as lag bolts) used in applications other than concrete (such as wood framing), **shall** provide equivalent strength to the concrete anchor. See GR-63-CORE-2006 for more information.
- Fastening systems used for wall-mounted equipment **shall** withstand a force of three times the weight of the equipment applied to the equipment in any direction (GR-63-CORE-2006).

**NOTE**

Wall-mounted equipment listed to the latest edition of UL 60950 (IEC 60950-1), Safety of Information Technology Equipment, conforms to this requirement (GR-63-CORE-2006).

9.5.1.3 Equipment Rack and Cabinet Requirements

- Equipment racks and cabinets **shall** be certified as being compliant with Telcordia GR-63-CORE (or equivalent) testing requirements.
- Equipment racks and cabinets (framework) **shall** be constructed for base mounting to the floor without the need for auxiliary support or bracing from the building walls or ceilings (see GR-63-CORE-2006 for more information).
- Equipment racks and cabinets (framework) should be of welded construction (GR-63-CORE-2006).

**NOTE**

Many rack manufacturers only offer “standard” racks and racks rated for Zone 4 applications. Standard racks require auxiliary support in Zones 1, 2 and 3. Standard racks are not permitted in Zone 4 applications, except under the guidance of a seismic engineer.

- Racks and cabinets **shall not** be loaded beyond the maximum rated capacity of the framework (ATIS 0600336.2009).
- Unless otherwise permitted, racks and cabinets **shall** meet the minimum seismic testing requirements for the Seismic Zone they will be installed in, as defined by GR-63-CORE-2006. For example, a rack installed in a Seismic Zone 3 location **shall** be rated for Zone 3 or Zone 4.
- A specifically engineered rack and/or cabinet mounting solution (from a seismic engineer) may supersede the requirements of this section.

9.5.1.4 General Requirements and Recommendations

Earthquake-resistant design should be contracted to a firm specializing in such work. Follow the design recommendations of the seismic engineering firm. In other cases observe the following general considerations:

9.5.1.4.1 Equipment Securing

- Equipment **shall not** be secured to both the shelter walls and floors, because dissimilar movement between these surfaces is likely in an earthquake.
- Equipment racks and cabinets **shall** be secured to the floor using the manufacturer recommended number of mounting holes and appropriate anchoring hardware as defined in “Concrete Anchors” on page 9-10, by the local building code or by the Authority Having Jurisdiction (AHJ).
- Cabinet designs with wide footprints can be used to help prevent cabinets from tipping over.
- Columns of cabinets stacked and bolted back-to-back present a very stable and wide footprint. The bottom cabinets **shall** be bolted to the floor for complete security.
- Some cabinets can be outfitted with outrigger-type support legs to prevent tip-over. These outriggers alone do not provide adequate earthquake protection, but are typically adequate if the cabinet is bolted to the floor.
- When installing equipment racks or cabinets on a concrete floor it is important to coordinate the location of anchors with the edge of the concrete and other anchors to ensure the concrete breakout strength is not reduced. Anchor placements and installations should meet the following requirements (see FEMA 413 “Installing Seismic Restraints for Electrical Equipment” for more information):
 - Do not install an anchor too close to a concrete edge. Typically the anchor distance from the edge should be 1½ times the embedment anchor depth.
 - Do not install an anchor too close to another anchor. Typically the minimum spacing between anchors should be two times the larger embedment anchor depth.
 - The depth of the concrete base **shall** be at least 2.54 cm (1 in.) greater than the anchor hole. Some undercut anchors may require a deeper concrete base.
 - Drilled holes **shall** be cleaned before inserting the anchor.
 - The anchor manufacturer's installation requirements **shall** be followed.
- Mounting should provide for some “sway” in the overall equipment supporting framework, thereby absorbing the energy of an earthquake. This is typically accomplished by rigid mounting of equipment racks or cabinets at the base (as described in this chapter), while semi-rigidly securing the rack or cabinet at the top. The benefit of this type of installation is that racks or cabinets are allowed to sway within limits, but can't fall over. The semi-rigid attachment can be made using one of the following methods:
 - Using a listed seismic wire rope or cable.
 - Using a seismic-rated brace designed to absorb shock (installed per manufacturer requirements).
 - Other specifically engineered solution.

9.5.1.4.1.1 Anchoring Seismic Wire Rope

Where seismic wire rope is used to semi-rigidly secure the top of equipment racks and cabinets, the wire rope **shall** be secured to the building structure using appropriate anchors. Wire rope/cable anchors should be secured to ceiling joists, building steel or other permanent building structures.

Where wire rope is secured to wood structures, lag bolts may be used. Where lag bolts are used to anchor wire rope to wood structures, it is important to coordinate the location of the lag bolts with the edges of the wood structure and other bolts to ensure the wood breakout strength is not reduced. Anchor placements and installations should meet the following requirements (see FEMA 413, “Installing Seismic Restraints for Electrical Equipment”, for more information):

- The distance between the bolt and the non-loaded edge (the edge opposite the direction of the load) of the wood structure should be no less than 1.5 times the bolt diameter (D) or 1.5D. See Figure 9-7.
- The distance between the bolt and loaded edge (the edge in the direction of the load) of the wood structure should be no less than 4 times the bolt diameter (D) or 4D. See Figure 9-7.
- If a strut is attached to the wood support structure, both edge distances are consider loaded. The distance between the bolt and each edge should be no less than 4 times the bolt diameter (D) or 4D. See Figure 9-7.

- The distance between the bolt and wood structure end edge should be no less than seven (7) times the bolt diameter (D) or 7D. See Figure 9-7.
- Spacing between bolts should be no less than four (4) times the bolt diameter (D) or 4D. See Figure 9-7.
- Do not anchor to the end grain of wood. See Figure 9-7.

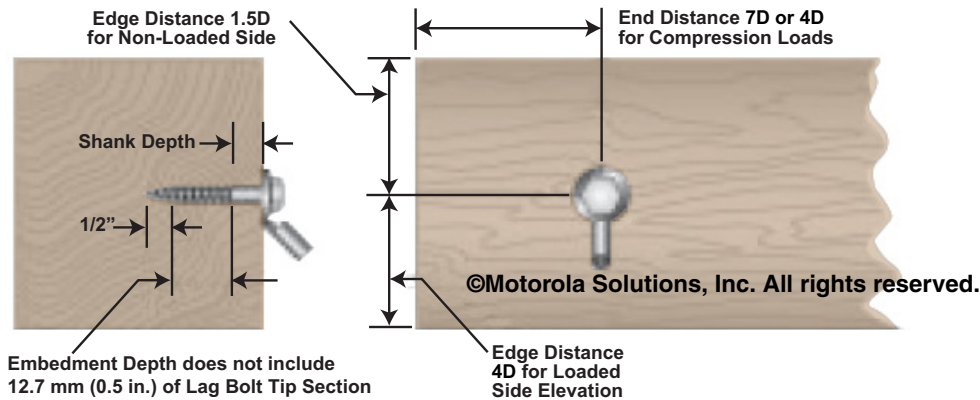

Figure 9-7 Anchoring Seismic Wire Rope

9.5.1.4.2 Computer Floor Applications

- Equipment installed on computer flooring **shall** be anchored to the sub floor as described in “Anchoring Equipment to Raised Floors” on page 9-21. Alternately, the equipment may be secured as shown in Figure 9-8, Figure 9-9 and Figure 9-10.
- Raised flooring systems appropriate for the Seismic Zone **shall** be used.
- Raised computer floors may lose structural integrity if panels are removed. This could lead to collapse of the raised floor during an earthquake. The flooring manufacturer **shall** be consulted if panels are to be permanently removed.

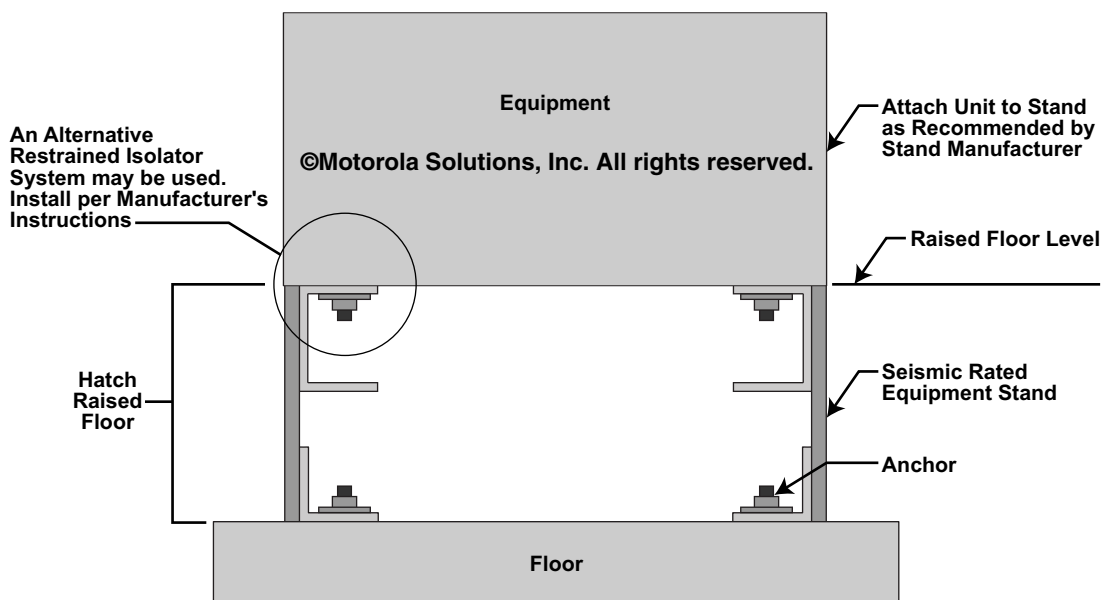

Figure 9-8 Equipment Installed on a Raised Floor: Secured to Seismic-Rated Equipment Stand

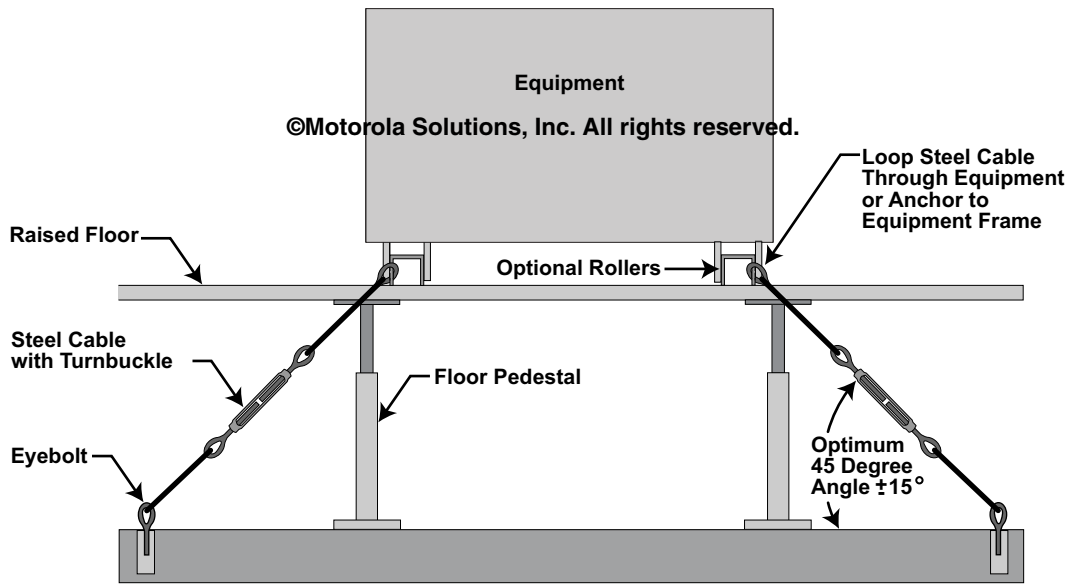

Figure 9-9 Equipment Attached to Cables Beneath a Raised Floor: Secured with Seismic-Rated Cables

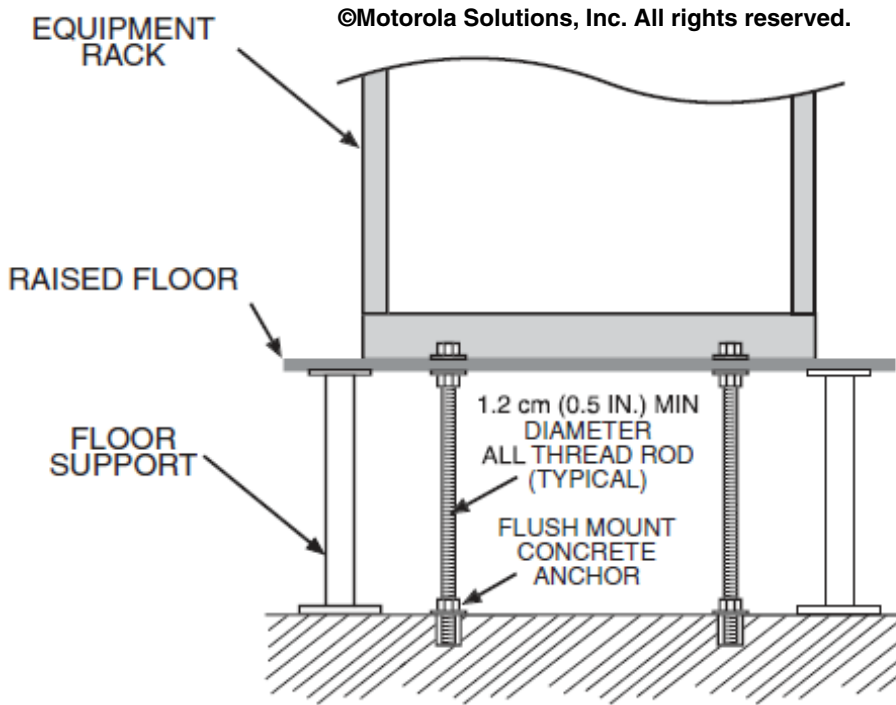

Figure 9-10 Anchoring Equipment to Raised Floors

9.5.1.4.3 Miscellaneous

- Cables and transmission lines **shall** be installed to allow the equipment rack or cabinet to sway. This is especially important when installing equipment on seismic floors that are designed to move during a seismic event.

- All ancillary equipment that is not mounted in a rack or cabinet, such as displays or control stations, **shall** be securely fastened to a mounting structure.
- Storage cabinets **shall** be secured to prevent tipping. Storage cabinets **shall** also have closable, secured doors to prevent contents from spilling during an earthquake.
- Ladders and other large objects **shall** be secured or removed from the equipment area when not in use.
- Lighting fixtures should be prevented from swaying excessively by the addition of guy wires.
- Fluorescent lighting fixtures **shall** have protective lenses or protective plastic sleeves which cover the fluorescent tube, preventing broken glass from falling on occupants.

9.5.2 Seismic Zone 0

No special techniques are typically required. Follow the normal installation requirements of this chapter. Follow all requirements of the Authority Having Jurisdiction.

9.5.3 Seismic Zones 1 and 2

Equipment securing and mounting in Seismic Zone 1 and 2 applications **shall** meet the following requirements:

- Follow all applicable installation requirements in this chapter.
- Follow the requirement and recommendations of “Seismic Requirements and Recommendations” on page 9-10 and all applicable subsections.
- Install equipment in racks and/or cabinets that are minimally rated for the Seismic Zone. The rack and/or cabinet **shall** be installed as required by the manufacturer. Alternately, a “standard” rack may be installed with appropriate top support as described in “Equipment Rack and Cabinet Requirements” on page 9-11.
- A specifically engineered rack and/or cabinet mounting solution (from a seismic engineer) may supersede the requirements of this section.
- Cable tray systems **shall** be rated for the Seismic Zone and installed as required by the manufacturer.
- Follow all requirements of the Authority Having Jurisdiction.

9.5.4 Seismic Zone 3

Equipment securing and mounting in Seismic Zone 3 applications **shall** meet the following requirements:

- Follow all applicable installation requirements in this chapter.
- Follow the requirement and recommendations of “Seismic Requirements and Recommendations” on page 9-10 and all applicable subsections.
- Install equipment in racks and/or cabinets that are rated for Seismic Zone 3 or 4. The rack and/or cabinet **shall** be installed as required by the manufacturer. Alternately, a “standard” rack may be installed with appropriate top support as described in “Equipment Rack and Cabinet Requirements” on page 9-11.
- Bolt the racks and/or cabinets using all available mounting holes or as otherwise required by the manufacturer.
- A specifically engineered rack and/or cabinet mounting solution (from a seismic engineer) may supersede the requirements of this section.
- Cable tray systems **shall** be rated for the Seismic Zone and installed as required by the manufacturer. To meet the seismic requirements, the cable tray may require additional support, such as a seismic wire rope or cable. Consultation with the cable tray manufacturer and/or seismic engineering firm is recommended. See Figure 9-11.
- Follow all requirements of the Authority Having Jurisdiction.

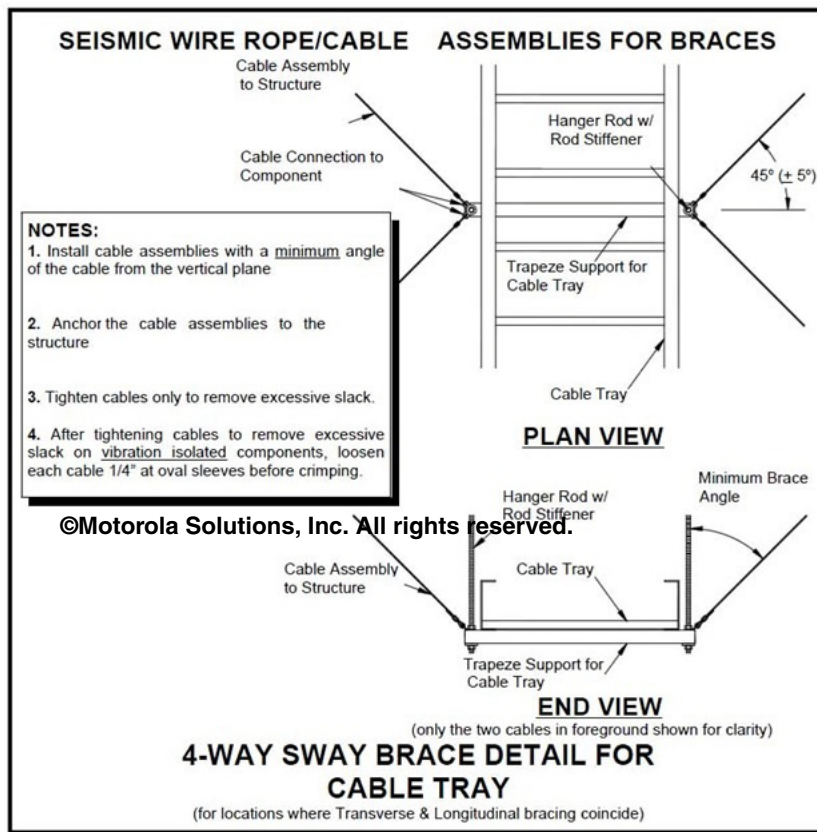

Figure 9-11 Brace Detail for Cable Tray

9.5.5 Seismic Zone 4

Consultation with an engineering firm is required in Seismic Zone 4 applications. Equipment securing and mounting in Seismic Zone 4 applications **shall** meet the following requirements or as otherwise designed by a seismic engineering firm:

- Follow all applicable installation requirements in this chapter.
- Follow the requirement and recommendations of “Seismic Requirements and Recommendations” on page 9-10 and all applicable subsections.
- Install equipment in racks and/or cabinets that are rated for Seismic Zone 4. The rack and/or cabinet **shall** be installed as required by the manufacturer.
- Bolt the racks and/or cabinets using all available mounting holes or as otherwise required by the manufacturer.
- Cable tray systems **shall** be rated for the Seismic Zone and installed as required by the manufacturer. To meet the seismic requirements, the cable tray may require additional support, such as a seismic wire rope or cable. Consultation with the cable tray manufacturer and/or seismic engineering firm is recommended. See Figure 9-11.
- Follow all requirements of the Authority Having Jurisdiction.

9.6 Level, Plumb and Squareness

- Equipment **shall** be level, plumb and square.
- Equipment level **shall** be tested on a known flat surface in at least two directions to verify accuracy.

9.7 Equipment Anchoring

Anchoring is the mechanical fastening of communications equipment to suitable locations using hardware acceptable for the application. Although every installation is unique, certain methods for anchoring **shall** be adhered to for all installations. Typically, at least four anchor points **shall** be used on each item of equipment mounted to the floor. The only exception is when the equipment manufacturer supplies other than four mounting points.



NOTE

Where seismic concerns exist (Moment Magnitude rating 3 or greater), see “Seismic Considerations” on page 9-9 for additional information and requirements (GR-63-CORE section 4.4.2).

The requirements for securing racks and cabinets are as follows:

- All racks and cabinets **shall** be anchored in order to prevent movement or tipping. The movement of racks or cabinets can damage equipment and cabling.
- Cabinet columns may be placed on C-channel tracks or wooden pedestals.
- In seismic areas, selected anchors **shall** meet standards set forth in NEBS (Network Equipment Building Systems) TR-64 and ASTM (American Society for Testing Materials) 488-90 for earthquake compliance.
- Floor anchors **shall** be secure and **shall not** protrude above the floor level (the part that goes into the hole, **not** the bolt).
- Floor and wall anchors **shall** be the proper types in accordance with equipment specifications. Types and sizes installed **shall** be in accordance with support requirements of intended load.
- Shields and anchors **shall not** be loose or so tight as to prevent expansion. Anchors **shall** be torqued to manufacturer's specifications.
- Unused holes in floors **shall** be filled with an appropriate concrete fill after shields and anchors are removed.

9.7.1 Mounting on Concrete Floors



CAUTION

Before drilling into concrete floors, contact the building engineer and/or site owner to determine floor construction (for example, prestressed concrete, and so on). If engineering as-built drawings are not available for the site, X-rays of the area to be drilled for the anchors are required to determine the location of structural components and rebar.

9.7.1.1 General Requirements

Equipment racks or cabinets should be positioned and anchored to the floor using preferred mounting methods. Figure 9-12 shows proper concrete mounting techniques and materials. In general, observe the following considerations:

- An anchor specifically designed for concrete **shall** be used. The preferred method for anchoring racks or other ancillary equipment to concrete floors is to use flush-mount expansion anchors properly sized for the application. Flush mount expansion anchors do not extend above the surface of the floor and provide an easy bolt down. They also provide the required pullout and shear strength. If at a later time equipment needs to be moved, flush mount expansion anchors do not get in the way.
- Unless an isolating mounting system is used (see “Isolated Mounting” on page 9-19), ensure that no anchors come in contact with reinforcing rods or wire mesh buried in the concrete. If preferred or acceptable, wedge-type stud anchors may be used.

- All concrete anchors **shall** be zinc-plated carbon steel for standard applications, galvanized steel for mildly humid or corrosive environments, and yellow zinc or stainless steel for humid, highly corrosive or acidic environments. Minimum bolt diameter **shall** be 10 mm (0.375 in.) with 12 mm (0.5 in.) preferred. Anchor embedment depth should be at least 76 mm (3 in.) to provide good tensile and shear strength. Follow manufacturer's instructions for depth reduction when rebar is encountered. A heavy duty washer should be part of the anchor assembly to ensure the equipment is secure.

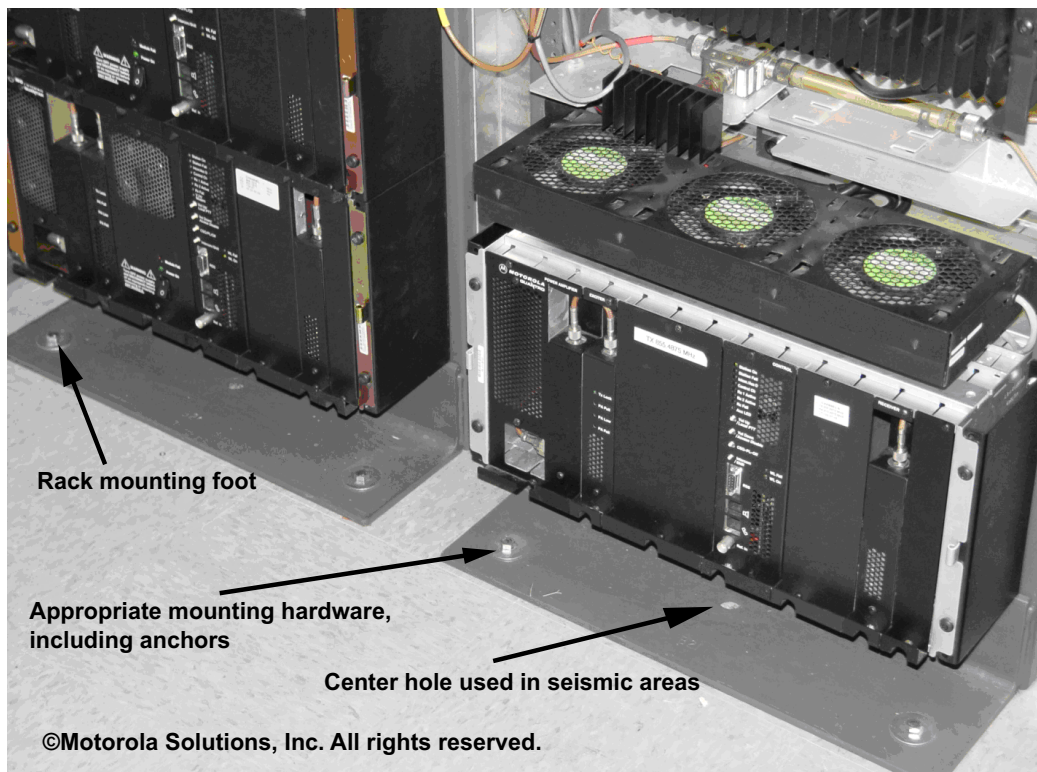

Figure 9-12 Rack Floor Mounting

9.7.1.2 Seismic Anchoring

Seismic anchors are designed, tested and specified for seismic zones 3 and 4. The use of seismic anchors enhances the stability of equipment due to the special characteristics specifically suited to the dynamic and cyclic loading effects experienced during earthquake events. As such, anchors **shall** be used that are manufactured to particular specifications that make them the most resistant to the effects of dynamic and cyclic loading effects. Selected anchors **shall** meet standards set forth in NEBS (Network Equipment Building Systems) TR-64 and ASTM (American Society For Testing and Materials) 488-90 for earthquake compliance. This testing evaluates anchors for bolt failure from shearing and from pullout or slippage. Compliance with these standards requires that the anchor not allow a standard top heavy 2.2 m (7 ft) rack to have a deflection greater than 762 mm (3 in.) at the top of the frame. This compliance will also adhere to Bellcore Technical Specifications AU-434 for earthquake concrete expansion anchors.

Anchor selection criteria **shall** comply with all general requirements for standard concrete anchors and meet the seismic requirements described in this section.



NOTE

For seismic installation, concrete **shall** be a minimum of 206.73 MPa (3000 PSI or 2109.23 Tonnes/m²) rating, at a minimum of 152.4 mm (6 in) thickness (per Bellcore specification TR-64).

The following steps describe proper concrete mounting techniques and materials.

1. Using the appropriate pattern, drill 18mm (11/16 in.) holes. Hole depth **shall** be 102 mm (4 in.) minimum below floor tile.
2. Vacuum all drilling dust, including the drilled holes, with a 0.3 micron HEPA filter or better. Alternatively, place the vacuum outside and extend only the hose into the shelter. If any existing equipment is in the site, cover it with an anti-static tarp or covering to prevent dust from entering.
3. Insert approved anchors (sleeved concrete anchors as shown in Figure 9-13) into each hole until plate washer is flat against the floor surface.

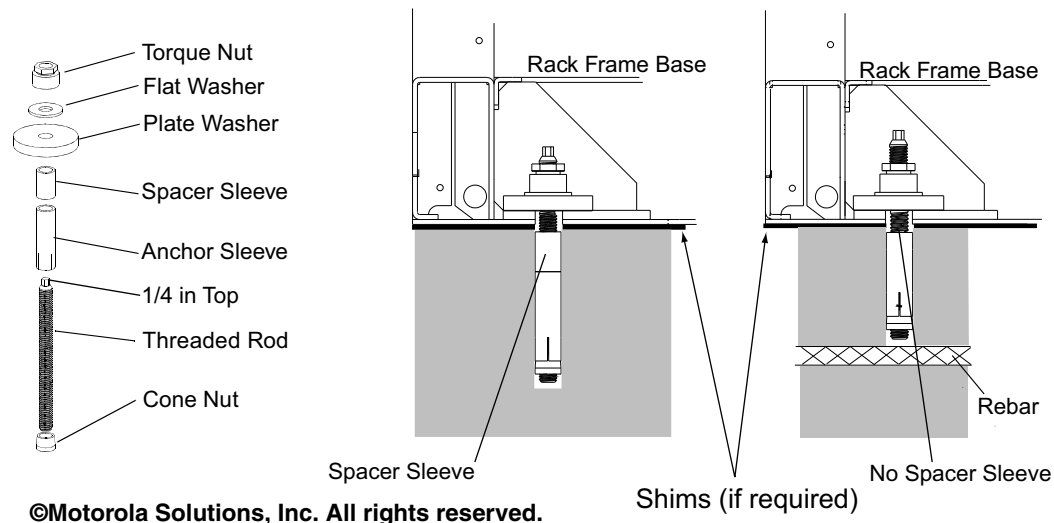

Figure 9-13 Anchor Installation



NOTE

If rebar is encountered with the standard anchor, remove the spacer and install the anchor without it.

4. Tighten anchor nuts to 67.8 N-m (50 ft-lbs).
5. Place the cabinet in position, ensuring that the mounting holes align with those in the floor.
6. Break nuts loose and remove the rods using the 6.35 mm (1/4 in.) drive top.
7. Insert the threaded rods into the anchors and install the nuts loosely to allow leveling and the installation of any shims required.
8. Level the rack and insert shims as required.
9. Using a wrench, tighten the lock nuts until the tops twist off.

9.7.1.3 Isolated Mounting

Isolated mounting is recommended to prevent a secondary path to earth (ground loop and stray current) through the concrete floor and is required for the installation of certain equipment. In these cases, expansion anchors are inserted into the concrete floor. However, isolation of the equipment rack is ensured using an insulating plate and hardware as shown in Figure 9-14.

If the installation is in an earthquake zone, additional anchors are used as shown in Figure 9-13.

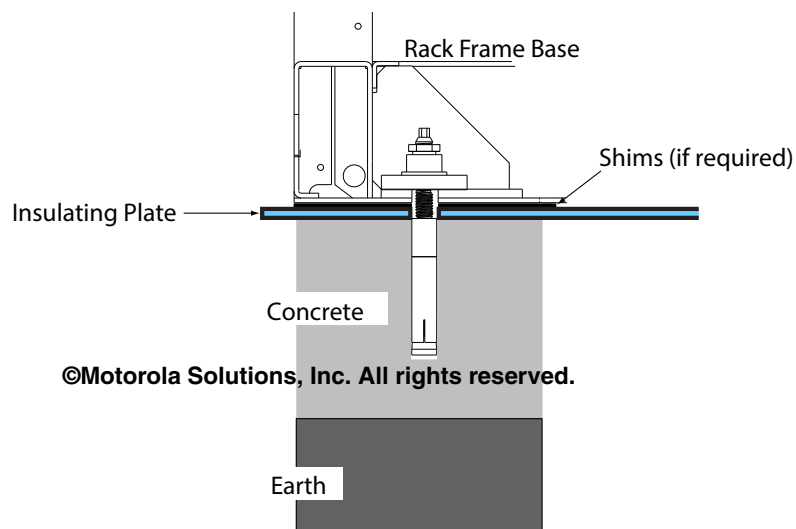

Figure 9-14 Isolated Mounting System



NOTE

The isolation plate should be made of an insulating material such as fiberglass or polypropylene plastic that will not deteriorate in varied temperature ranges.



NOTE

Isolated mounting is recommended when equipment racks are bolted to a concrete floor that is in direct contact with earth. This is to help prevent ground loops and stray currents. If the equipment is placed on vinyl or other non-conductive floor tile, no insulating plate is required; however, insulating washers or sleeves are required.



NOTE

If ESD rated floor tile is being utilized, an insulating plate and washer/sleeve are required.

9.7.2 Mounting on Wood or Similar Surfaces

When equipment is installed in a building with wood floors, special consideration must be given in order to provide adequate equipment anchoring. In some applications, an engineering firm may be required to design suitable equipment anchoring. The following paragraphs provide guidance when anchoring equipment to wood floors. Floor loading must also be considered. See “Floor Loading” on page 3-7 for more information on floor loading.

Appropriately sized anchoring hardware **shall** be used when mounting equipment on wood or similar floors. Additionally, the bolts **shall** pass through the wood and into the floor support structure. If the underside is accessible and the floor stability is questionable, then through-bolting may be desirable.

Minimum lag bolt diameter **shall** be 10 mm (0.375 in.) with 12 mm (0.5 in.) preferred. Lag bolt **shall** penetrate at least 76 mm (3 in.) of wood to provide good tensile and shear strength. A heavy duty washer should be part of the anchor assembly to ensure the equipment is secure. If there is not 76 mm (3 in.) of floor structure to penetrate, then an adequate support system **shall** be engineered. This may include a “C-channel” type mounting system or blocking.

It is recommended that base stations and other non-racked ancillary equipment are mounted on a “C-channel” type of mounting track where practicable. This provides for easy cleaning and some isolation in the case of standing water. Another benefit of installing non-rack mounted equipment off the floor is that the weight is distributed across the floor. In these cases, C-channel type mounting provides multiple floor anchor points, whereas the equipment provides only four to six anchor points.

Table 9-1 lists some of the available types of anchoring hardware.

Table 9-1 TYPES OF ANCHORING HARDWARE

Anchor Type	Minimum Diameter	Minimum Length	Material
Lag Bolts	9.5 mm (3/8 in.)	76 mm (3 in.)	Corrosion Resistant Steel
Toggle Bolts	9.5 mm (3/8 in.)	Application Specific	Corrosion Resistant Steel
“C-Channel” Type Mounting Systems	9.5 mm (3/8 in.)	38 mm (1.5 in.)	Corrosion Resistant Steel
4X4 Beams Anchored to Floor Joists - Equipment Then Anchored to the 4X4's	9.5 mm (3/8 in.)	76 mm (3 in.)	Corrosion Resistant Steel

9.7.3 Anchoring Equipment to Raised Floors

At least four anchor points **shall** be used on each item of equipment mounted to the floor. See Figure 9-15. The only exception is when the equipment manufacturer supplies fewer than four mounting points. When mounting racks to raised floors, 13 mm (0.5 in.) minimum diameter threaded rod and flush mount expansion anchors **shall** be used to anchor to the concrete sub-floor. When mounting equipment to a raised floor, 10 mm (0.375 in.) minimum threaded rod and hardware **shall** be used for anchoring. Mounting arrangement **shall** be in accordance with rack manufacturer's instructions.

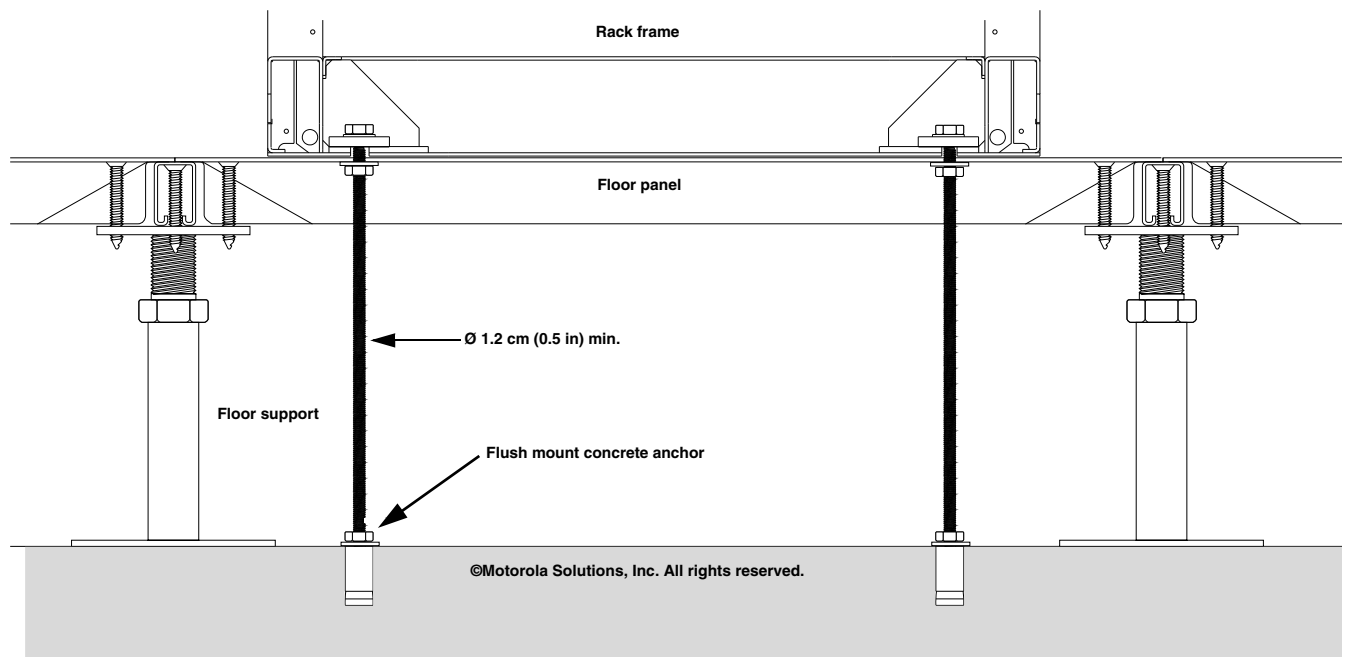

Figure 9-15 Raised Floor Anchoring

9.7.4 Anchoring Overhead and Wall-Mounted Equipment

The anchoring of overhead and wall-mounted devices presents a number of considerations. Placement is very important. If equipment is bolted to a wall that is on an aisle, the aisle may be unacceptably narrowed and result in potential danger of injury to personnel.

Overhead applications generally include coaxial cabling, cable trays and mounts for earthquake bracing. All overhead applications should keep loading of overhead surfaces in mind. Care must be exercised when determining the load that can be supported by the ceiling without building foundation support.

When anchoring cable trays to ceilings or walls, the manufacturer-minimum required support hardware **shall** be used.

Anchors used in overhead applications vary depending on the ceiling structure as follows:

- For concrete and wood ceilings, the principles discussed in “Equipment Anchoring” on page 9-17 apply.
- For an exposed steel I-Beam ceiling, beam clamps for C-channel or threaded drop rods can be used.
- For corrugated steel ceilings, C-channel tracks can be affixed to the ceiling using properly sized lag bolts. The C-channel spans the corrugated steel and provide multiple anchor points.

For drywall or plasterboard ceilings, special considerations are required:

- If the drywall is on steel or wooden roof joists, locate and tap into the roof joists with lag bolts.
- C-channel mounting may be used.



NOTE

Make certain joists are properly located before drilling into drywall. If any existing equipment is on site, ensure it is covered with an anti-static tarp or covering.

9.7.5 Equipment on Wheels

Equipment, racks and cabinets mounted on wheels **shall** be anchored. The same requirements apply to equipment, cabinets and racks on wheels as apply to non-wheeled items.

9.8 Equipment Installation Within Racks or Cabinets

Most communications equipment is mounted in standard 19-in. EIA racks or enclosed cabinets. Follow the rack and/or equipment manufacturer's instructions when installing equipment into racks or cabinets.

- All supplied bracing hardware **shall** be properly utilized.
- Proper hardware **shall** be used to secure equipment.
- Convected heat transfer from one piece of equipment rack to another **shall** be considered. Heat baffles or fan kits may be required. Do not block fans or ventilation with items placed on top of cabinets or equipment in racks.
- Equipment installed in a rack or cabinet but not bolted in place (for example, computer, computer monitor, and so on) **shall** be secured. See Figure 9-16 for examples.
- Heavy equipment **shall not** be mounted at the top of the equipment rack or cabinet. It may cause the rack to become top-heavy and unstable.

See Chapter 5, “Internal Bonding and Grounding (Earthing)”, for proper equipment bonding and grounding.



Figure 9-16 Example of Securing Equipment

9.9 Ancillary Equipment Mounting

Any permanent site equipment that is not mounted in a rack or cabinet **shall** be secured or mounted, including items placed on rack-mounted or cabinet-mounted peripheral trays.

9.10 Equipment Cabling

The following subsections describe the recommendations and requirements for cabling within buildings, equipment cabinets and racks, and requirements for cable runs between equipment cabinets/racks.

9.10.1 Cable Installation Requirements

Requirements for building cabling are as follows.

9.10.1.1 General Cable Installation Requirements

- Communications wires, cables, coaxial cable and raceways installed in buildings **shall** be listed (NFPA 70-2017, Articles 800.113, 800.179, 820.113, 830.113 and 840.154).
- Communications circuits, equipment and coaxes **shall** be installed in a neat and workmanlike manner (NFPA 70-2017, Articles 725.24, 800.24, 820.24 and 830.24).
- Communications cables installed in hazardous areas as defined in NFPA 70-2017, Article 500 **shall** be installed according to NFPA 70-2017, Article 500, other applicable electrical and building codes, and the Authority Having Jurisdiction (AHJ).
- See the following sections for cable bending radius requirements.

9.10.1.2 Support and Securing

- Communications cables and coaxes **shall not** be attached by any means to the exterior of a conduit or other raceway as a means of support (NFPA 70-2017, Articles 725.143, 800.133(B) and 820.133(B)). An example of incorrectly secured cabling is provided in Figure 9-17.

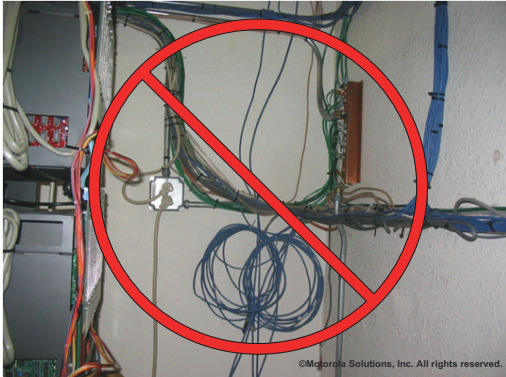

Figure 9-17 Example of Incorrectly Secured Cabling

- Communications cables and coaxes **shall not** be laid directly on the tiles or grid work of a false ceiling (NFPA 70-2017, Articles 300.11, 725.21, 800.21, 820.21 and 830.21; and TIA-569-D, section 9.5.2.1).
- Communications raceways, cables and coaxes **shall not** be supported by ceiling-support wires (NFPA 70-2017, Articles 725.24, 800.24, 820.24 and 830.24; and TIA-569-D, section 9.8). Additional ceiling-support wires can be installed for the purpose of supporting communications raceways and cables. Where independent support wires are used, they **shall** be secured at both ends (NFPA 70-2017, Article 300.11(A)). See Figure 9-18.

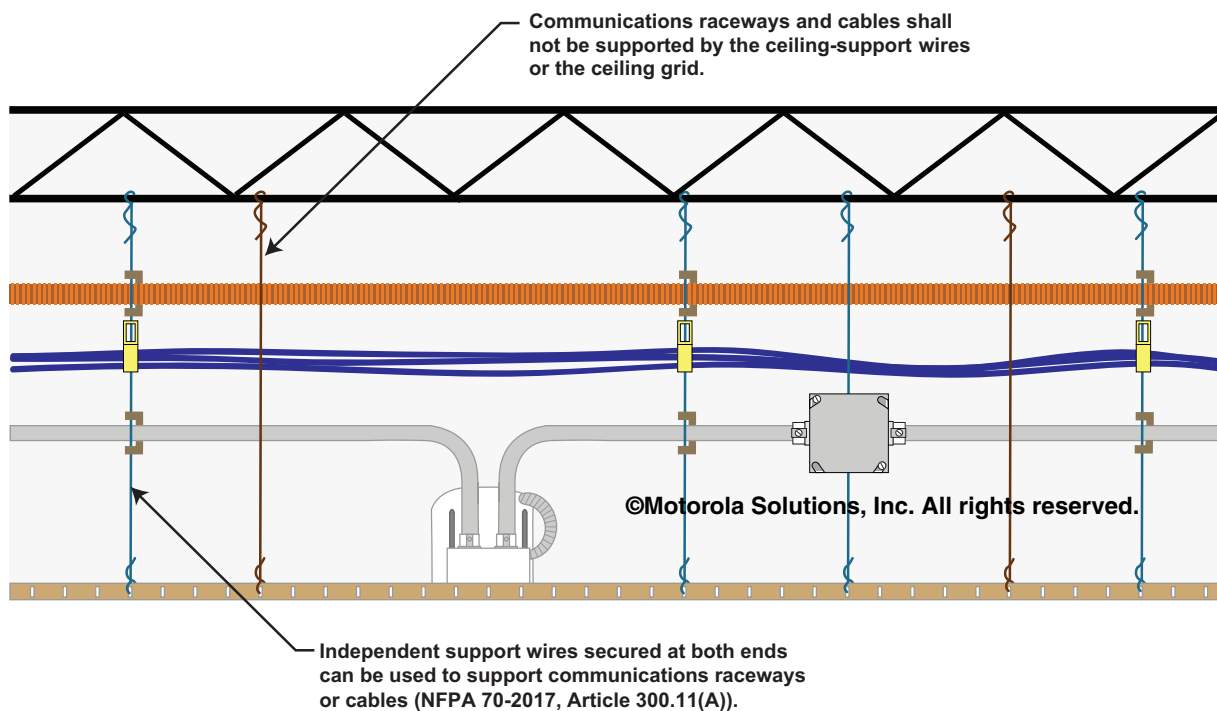

Figure 9-18 Running Cables and Raceways in a Ceiling Space

- Do not over-tighten communications cables with cable ties or other supports. Over-tightening cable ties or other supports can negatively affect the electrical characteristics of the cable and degrade performance. Velcro®-style cable ties (or equivalent) are recommended for computer network and E1/T1 cables. See TIA-568-C for additional information.

9.10.1.3 Separation From Noise Sources and Other Cable Groups

- Communications cables **shall** be separated by at least 50.8 mm (2 in.) from conductors of any electric light, power, Class 1, non-power-limited fire alarm or medium-power network-powered broadband communications circuits (NFPA 70-2017, Article 800.133(A)(2)).
- Balanced twisted-pair cabling should be separated from fluorescent lamps and associated fixtures by a minimum of 125 mm (5 in.) (TIA-569-D, section 9.3.2).
- Avoid routing communications cables near sources of Electromagnetic Interference (EMI) and Radio Frequency Interference (RFI). Routing cables near sources of EMI or RFI can cause data errors and/or degraded system performance. Such noise sources include, but are not limited to, the following: electrical power wiring, electrical transformers, dimmer switches, radio frequency transmitters, motors, generators and fluorescent lights. See TIA-569-D, Table 6 for more information.
- If routing communications cables near sources of EMI or RFI cannot be avoided, reasonable precautions **shall** be taken to minimize the EMI or RFI negative impact. Such precaution may include, but are not limited to, the following: increasing the physical distance between the communications cable and the source of the EMI/RFI, installing the communications cable inside a grounded metallic conduit; or use of a shielded communications cable. See TIA-568-C and 569-D for additional information.

9.10.1.4 Cabling Removal Requirements

Abandoned cables increase the fire loading of a building. The accessible portion of abandoned communications cables (including optical fiber cables) **shall** be removed (NFPA 70-2017, Articles 770.25 and 800.25). The following definitions apply:

- **Abandoned Communications Cable:** An installed communications cable that is not terminated at both ends at a connector or other equipment and not identified for future use with a tag (NFPA 70-2017, Article 800.2). Also see NFPA 70-2017, Articles 640.2, 645.2, 725.2, 760.2, 770.25, 820.2, 830.2 and 840.25.
- **Accessible:** Capable of being reached quickly for operation, renewal or inspection without requiring those to whom ready access is requisite to climb over or remove obstacles or to resort to portable ladders and so forth (NFPA 70-2017, Article 100).

The requirements in this section cover the portions of cable installation that are not permanently enclosed by the building structure or finish or are not capable of being removed without damaging the building structure or finish. Abandoned cables in a concealed raceway (for example, conduit) are not required to be removed. Abandoned cables under a computer floor **shall** be removed.

Unused communications cables identified for future use with a tag are not required to be removed. See Figure 9-19. Where cables are identified for future use with a tag, the tag **shall** be of sufficient durability to withstand the environment. See NFPA 70-2017, Articles 770.25 and 800.25.

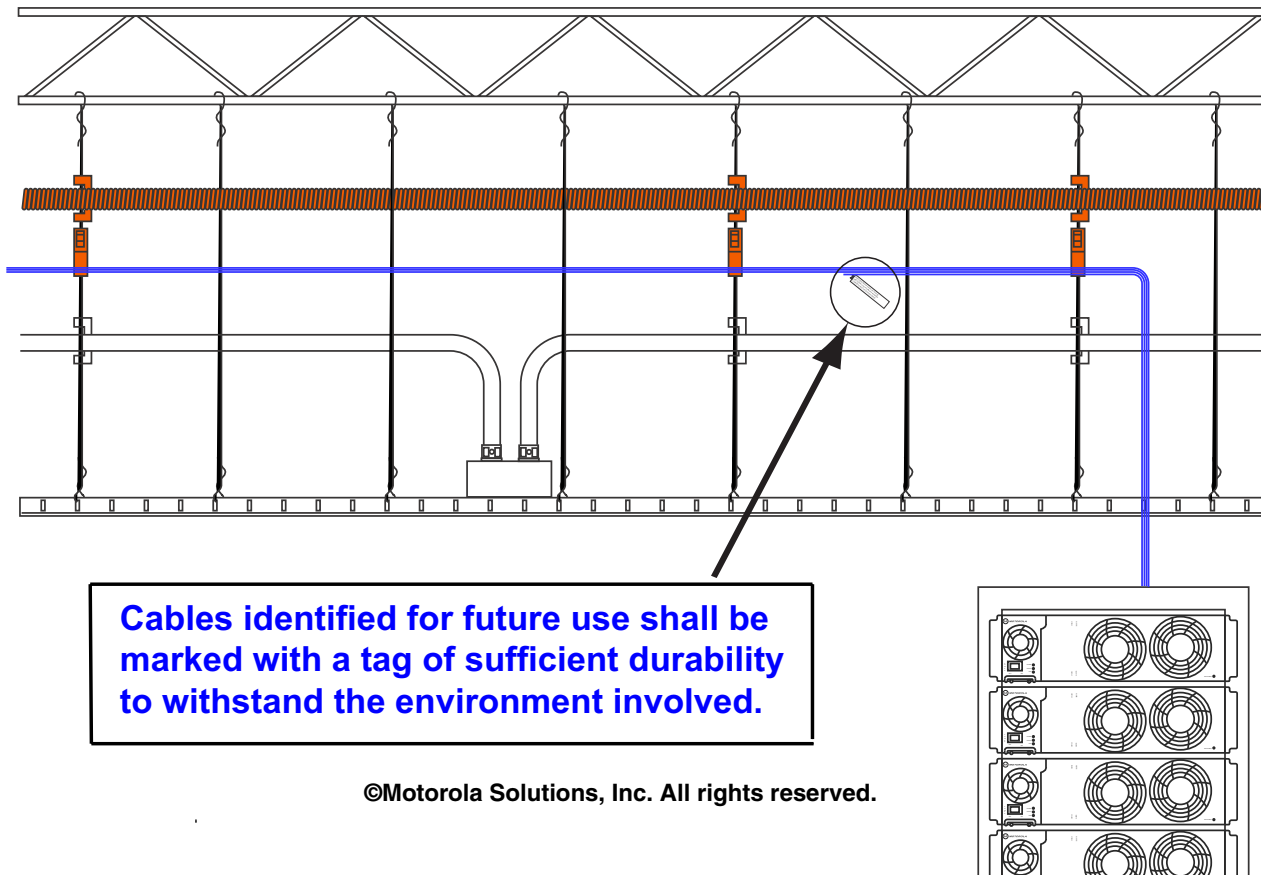

Figure 9-19 Unused Cable ID Tag

9.10.2 Communications Cabling Requirements for Plenums and Other Spaces Used for Environmental Air

A plenum is defined as a compartment or chamber to which one or more air ducts are connected and that forms part of the air distribution system (NFPA 70-2017, Article 100).

“Other spaces used for environmental air” are defined as spaces not specifically fabricated for environmental air-handling purposes but used for air-handling purposes as a plenum (NFPA 70-2017, Article 300.22(C)). This definition does not apply to habitable rooms or areas of buildings, the prime purpose of which is not air handling (NFPA 70-2017, Article 300.22(C)).

The space over a hung ceiling used for environmental air-handling purposes is an example of the type of other space to which this definition applies (NFPA 70-2017, Article 300.22(C) Informational Note 1). See Figure 9-20 and Figure 9-21.

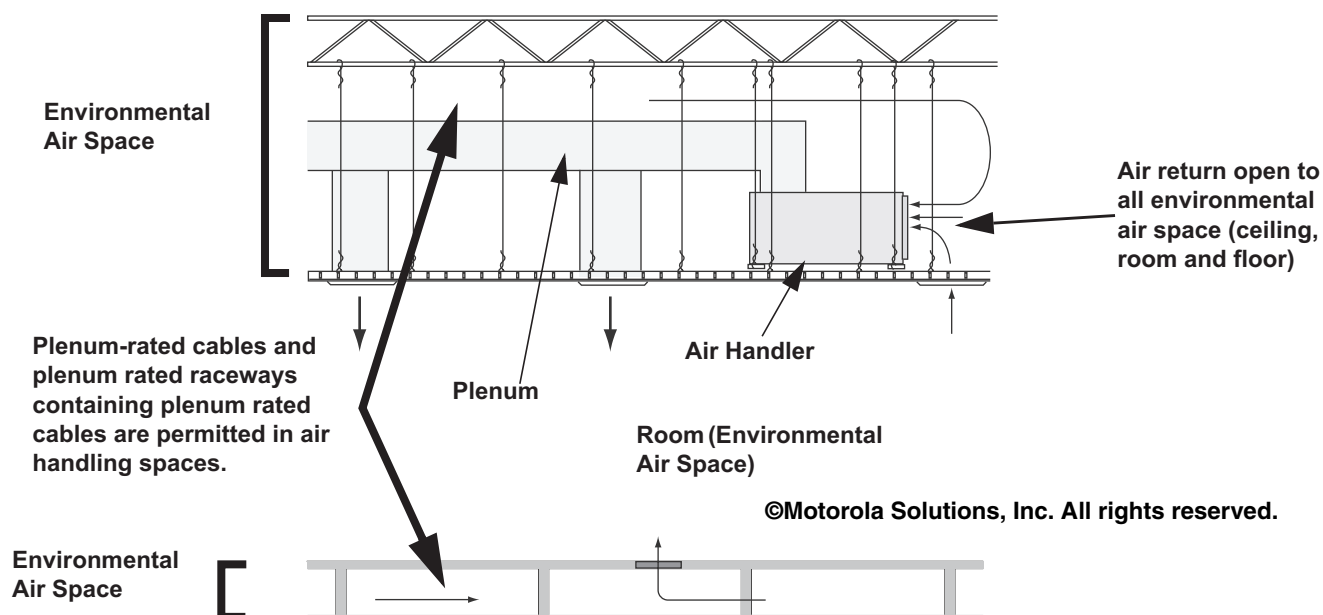

Figure 9-20 Air Handling Spaces - Wiring Restrictions

The following requirements specify installation practices that, should a fire occur, help minimize smoke and products of combustion from electrical wiring in areas that handle environmental air:



NOTE

The term “communications cable” is used generically in this section to describe communications cable, coaxial cable, computer network cable and optical fiber cable.

- Wiring systems of any type **shall not** be installed in ducts used to transport dust, loose stock or flammable vapors (NFPA 70-2017, Article 300.22(A)).
- Wiring systems of any type **shall not** be installed in any duct, or shaft containing only such ducts, used for vapor removal (NFPA 70-2017, Article 300.22(A)).
- Communications cables **shall not** be installed in a plenum (NFPA 70-2017, Article 300.22).
- Communications cables installed in spaces used for air handling (such as for return air) **shall** be plenum rated (such as type xxP) or specifically listed for use within an air handling space (NFPA 70-2017, Articles 300.22(C)(1), 725.154, 770.113, 800.113, 820.113 and 830.113). **Exception:** when the cable is installed in a metallic conduit as permitted by NFPA 70-2017, Article 300.22(C)(1)).
- Non-metallic communications raceways installed in other spaces used for air handling **shall** be plenum rated or specifically listed for use within an air-handling space (NFPA 70-2017, Articles 300.22(C)(1), 770.110, 800.110 and 820.110).
- Non-metallic communications raceways installed in other spaces used for environmental air **shall** only contain plenum-rated communications cables specifically listed for use within an air-handling space. The use of plenum-rated non-metallic communications raceway does not negate the requirement to use plenum-rated communications cables. See NFPA 70-2017, Articles 300.22, 770.110, 800.110, 820.110.
- A bare grounding conductor may be installed in a plenum area. If a bare conductor is used, it **shall** be properly secured and protected from making incidental contact with other metallic objects not meant to be bonded. Non-metallic plenum raceway may be used to prevent incidental contact.

- Wire ties, straps and other non-metallic hardware used to secure communications cables in other spaces used for environment air **shall** be listed as plenum rated, suitable for use in air handling spaces.



IMPORTANT

Non-metallic plenum-rated communications raceways installed in an air-handling space shall only contain plenum rated communications cables. The use of plenum-rated non-metallic communications raceway does not negate the requirement to use plenum-rated communications cables.



IMPORTANT

Communications cables installed in an air-handling space shall meet the installation requirements of the Authority Having Jurisdiction (AHJ). These requirements may differ from the requirements in this manual.

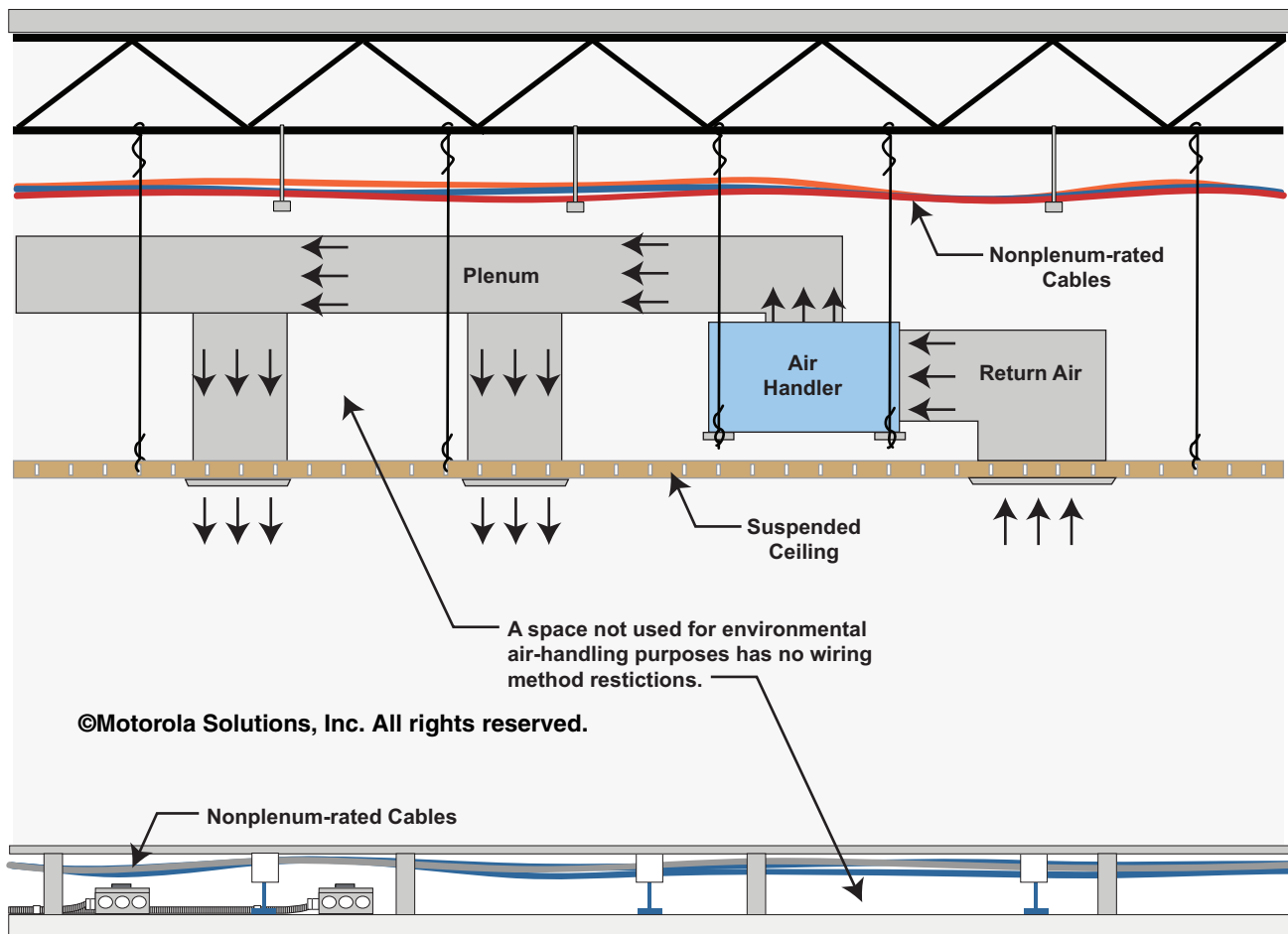

Figure 9-21 Spaces Not Used for Environmental Air - No Wiring Restrictions

9.10.3 Communications Cabling Requirements for Risers

The following requirements apply to communications cabling installed in a riser (vertical run):



NOTE

The term “communications cable” is used generically in this section to describe communications cables, coaxial cables, computer network cables and optical fiber cables.

- Communications cables penetrating one or more floors and cables installed in vertical runs in a shaft **shall** be riser or plenum rated (such as type xxR or xxP) (NFPA 70-2017, Articles 725.154, 770.113, 800.113, 800.154, 820.113 and 830.113). **Exceptions:**
 - Riser or plenum rated cable is not required if the cable is installed in a metal raceway and the metal raceway has approved fire stops at each floor (NFPA 70-2017, Articles 770.113, 800.113, 820.113 and 830.113).
 - Riser or plenum rated cable is not required if the cable is installed in a fireproof riser shaft and the shaft has approved fire stops at each floor (NFPA 70-2017, Articles 770.113, 800.113, 820.113 and 830.113).
- Non-metallic communications raceways installed in a riser **shall** be riser or plenum rated (NFPA 70-2017, Article 300.22(C)(1), 770.110, 800.110 and 820.110).



IMPORTANT

Non-metallic riser or plenum-rated communications raceways installed in a riser shall only contain riser or plenum rated communications cables. The use of riser or plenum-rated non-metallic communications raceway does not negate the requirement to use riser or plenum-rated communications cables.

- A bare grounding conductor may be installed in a riser. If a bare conductor is used, it **shall** be properly secured and protected from making incidental contact with other metallic objects not meant to be bonded to the grounding conductor. Non-metallic riser-rated or plenum-rated raceway may be used to prevent incidental contact.



IMPORTANT

Communications cables installed in a riser shall meet the installation requirements of the Authority Having Jurisdiction (AHJ). These requirements may differ from the requirements in this manual.

9.10.4 Fire Stopping Requirements

Electrical installations in hollow spaces, vertical shafts, and ventilation or air-handling ducts **shall** be installed in a manner such that the possible spread of fire or products of combustion will not be substantially increased. Openings around electrical penetrations into or through fire-resistance-rated walls, partitions, floors or ceilings **shall** be fire stopped using approved methods to maintain the fire resistance rating. See NFPA 70-2017, Articles 300.21, 800.26, 820.26 and 830.26; TIA-569-D; and NECA/BICSI 568-2006, section 5, for additional information.

Approved fire stopping products may include the following (NECA/BICSI 568-2006):

- Mechanical systems
- Mortar compounds
- Collar devices
- Blankets
- Caulks or sealants
- Putty
- Wrap strips

- Pillows or bags
- Sprays

The fire stopping product used **shall** be approved by the Authority Having Jurisdiction (AHJ) and **shall** be installed according to the manufacturer's instructions.



IMPORTANT

Check with the Authority Having Jurisdiction (AHJ) to determine fire stopping requirements. Also check with the AHJ to determine permitting and inspection requirements.



CAUTION

Openings around electrical penetrations into or through fire rated walls, floors and ceilings **shall** be properly fire stopped using products and methods approved by the AHJ. See Figure 9-22.

©Motorola Solutions, Inc. All rights reserved.

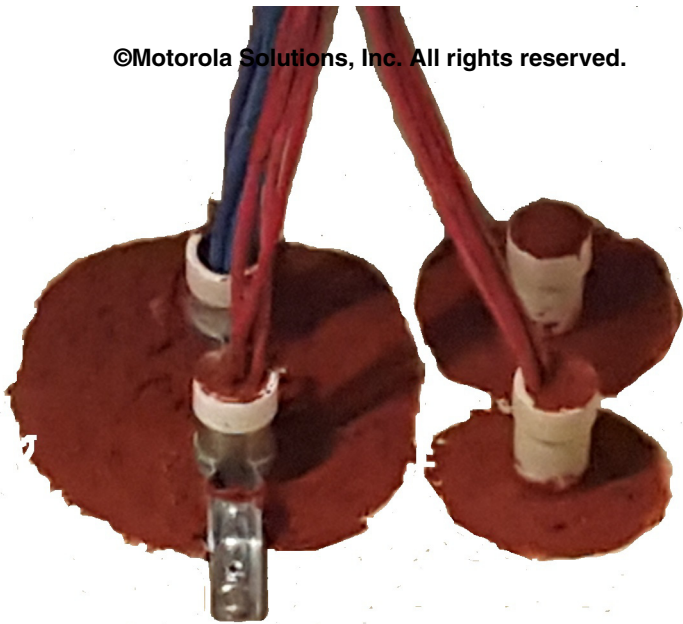

Figure 9-22 Fire-Stopping Electrical Openings

9.10.5 Cabling Requirements For Cable Trays or Ladders

The following subsections identify the different installation requirements for cabling in cable trays or ladders.

9.10.5.1 Cable Installation Within Cable Trays or Ladders

- Cables that span a horizontal gap greater than 610 mm (2 ft) **shall** be supported.
- Cables installed within a cable tray system **shall** be fastened securely to transverse members in all horizontal and vertical runs every 914 mm (36 in.).
- The most desirable method to exit the cable runway is to drop out the bottom (versus over the side) into a rack/cabinet or a vertical support such that physical separation is maintained.
- When installing cables into a cable tray system, cables **shall not** be pulled with such force that the conductor insulation or cable jacket integrity is destroyed or that the cable is deformed.

- Antenna and transmission lines minimum bending radii **shall** be considered when placing these cables within the cable tray. Follow manufacturers' specifications.
- AC power cables **shall not** be run within a cable runway system unless they are enclosed within an approved conduit or raceway or are otherwise approved for installation in cable trays (see NFPA 70-2017, Article 392).
- Cables run in a cable tray **shall** adhere to the requirements set forth in NFPA 70-2017 (see NFPA 70-2017, Articles 336 and 392).
- For DC Power Cabling requirements, see “DC Power Cabling” on page 9-36.



NOTE

Raceways or conduits installed below or alongside cable runways may not be supported by the cable runways unless the cable runway system is designed to provide such support and such installation is approved by the Authority Having Jurisdiction. Raceways or conduits may be supported by the same supporting hardware as the cable runway system. See NFPA 70-2017, Articles 314.1 and 392.18(G).

9.10.5.2 Cable Separation and Grouping Within Cable Trays and Ladders

- Cable groups **shall** be separated a minimum of 50.8 mm (2 in.) from other cable groups. See TIA-568-C and 569-D; NFPA 70-2017, Articles 800.133, 820.133 and 830.133; and Figure 9-23 for additional information.

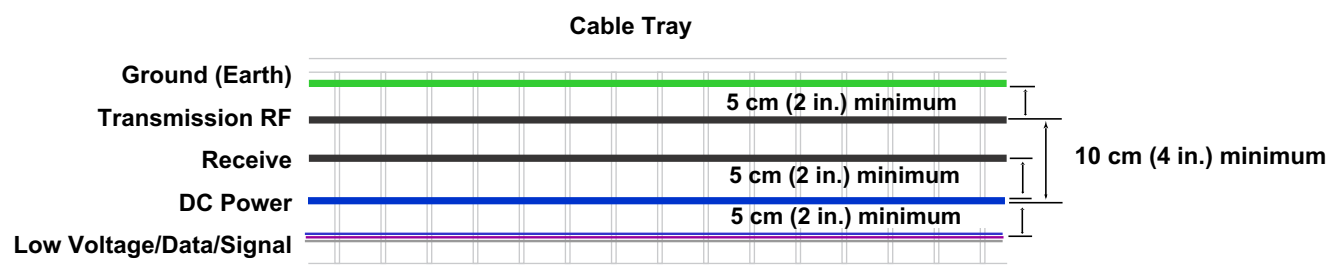

©Motorola Solutions, Inc. All rights reserved.

Figure 9-23 Minimum Cable Group Separation In Cable Tray

- Groups are defined as:
 - AC power
 - DC Power
 - Grounding/bonding conductor
 - RF transmission cabling
 - Data, control, signal and timing reference cabling and telephone cabling
- Transmission lines (coax) for transmitting stations **shall** be separated a minimum of 101 mm (4 in.) from electrical light, power and signaling circuits (NFPA 70-2017, Article 810.70).
- At a minimum the group separation described in this section **shall** be maintained. However, with adequate cable tray space, logical sub-groups are permitted, such as bundles of DC cabling or bundles of RF cabling.
- AC power cables **shall not** be run in the same cable tray as network or communications cables unless separated by a barrier as defined by NFPA 70-2017 (such as Electrical Metallic Tubing). See “Computer Network Cabling” on page 9-37.

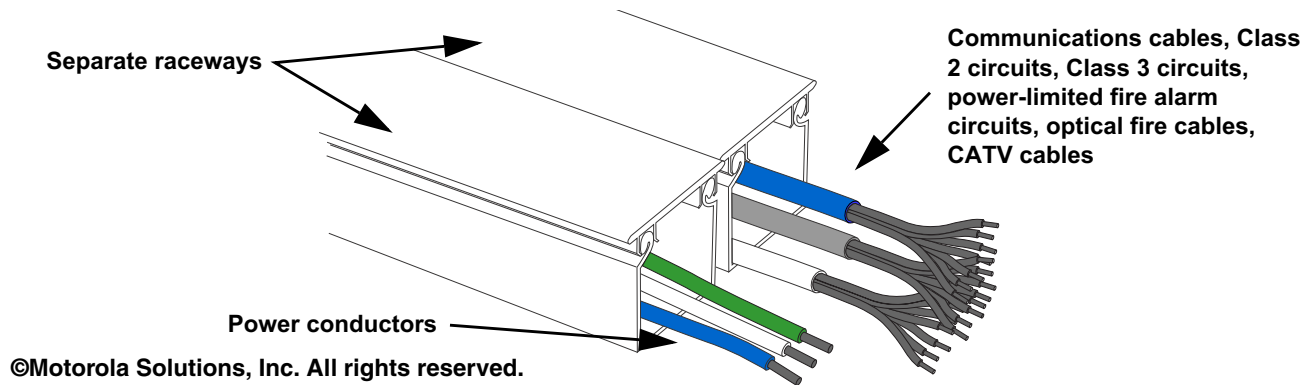

Figure 9-24 Use of Raceways for Cables

9.10.5.3 Securing Cables Within Cable Trays and Ladders

- Cables and conductors **shall** be secured at intervals of no more than 914 mm (36 in.).
- Cable fasteners, ties and securing devices **shall** be non-metallic.
- Cable securing **shall** be tight enough to secure the cables without crushing, deforming or pinching them.
- Waveguide and other RF transmission lines may be secured with metallic fasteners designed for the purpose.
- Cables running vertically on a cable ladder **shall** be secured at a minimum of 914 mm (36 in.). It is recommended that the cables are secured at every rung.
- Where cables span a gap (such as between a cable tray and a ladder) in excess of 610 mm (24 in.), the cables **shall** be supported.
- Cables **shall** be sized to length including a sufficient service loop. Excess cable **shall not** be coiled on top of cabinets or cable trays.
- Certain telephony requirements may exist for cables to be laced. See “Cabling in Telephone Wiring Environments” on page 9-59 for additional information.



Figure 9-25 Proper Securing of Cables in Cable Tray

9.10.5.4 Cable Bending Radius Within Cable Trays and Ladders

- The minimum inside bend radius for twisted-pair cables **shall** be four times the cable diameter or as otherwise required by the cable manufacturer (see TIA-568-C for additional information).
- The minimum inside bend radius for a patch cord **shall** be one times the cable diameter (TIA-568-C).
- The minimum inside bend radius for shielded twisted-pair cables **shall** be eight times the cable diameter or as otherwise required by the cable manufacturer (see TIA-568-C for additional information).
- See “Network Cable Bending Radius” on page 9-49 for computer network cable bending radius requirements.
- See “Optical Fiber Cabling Bending Radius” on page 9-54 for optical fiber bending radius requirements.
- The minimum inside bending radius of E1/T1 cables **shall** follow the requirements for computer network cables described in “Network Cable Bending Radius” on page 9-49 or as required by the cable manufacturer.
- All other cables **shall not** have sharp bends which will damage or degrade the performance of the cable. The cable manufacturer's specifications **shall** be followed.
- Grounding conductors of all sizes **shall** maintain a minimum bending radius of 203 mm (8 in.) as described in Chapter 5, “Internal Bonding and Grounding (Earthing)”.

9.10.6 Cabling Requirements for Equipment in Racks and Cabinets

All cables **shall** be installed and routed so that personal safety and equipment functionality is not compromised and that all equipment is accessible for servicing. The following requirements apply to cabling installed in racks or cabinets:

9.10.6.1 Routing Cables Within Racks and Cabinets

- Consideration should be given to using some method of cable management within the rack. See Figure 9-26 for an example.

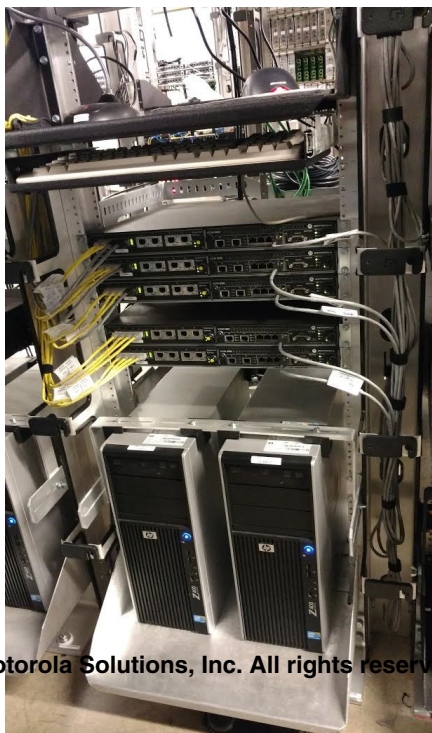

©Motorola Solutions, Inc. All rights reserved.

Figure 9-26 Cable Management System

- Cables in racks or cabinets **shall** be installed and routed in a neat and workmanlike manner.
- Cables in racks or cabinets **shall** be sized to length.
- AC power cords should be sized according to the length needed. AC power cords longer than necessary may be looped down and back up a rack or cabinet. Excess lengths of AC power cord **shall not** be coiled on top of racks or cabinets.
- Grounding conductors within racks or cabinets **shall** be installed and as described in Chapter 5, “Internal Bonding and Grounding (Earthing)”.

9.10.6.2 Securing Cables Within Racks or Cabinets

- To help prevent damage or accidental disconnection, cables and conductors **shall** be secured at intervals of no more than 914 mm (36 in.). Attachment **shall** be accomplished in a manner that does not restrict access to the equipment in the rack or cabinet.
- Insulated standoffs can be used in racks or cabinets as a means of cable management. The standoffs should be of sufficient length to maintain the proper cable separation.
- Cable fasteners, ties and securing devices **shall** be non-metallic.
- Cable securing **shall** be tight enough to secure the cables without crushing, deforming or pinching them.
- Waveguide and other RF transmission lines may be secured with metallic fasteners designed for the purpose.
- Nonmetallic cable ties **shall** be cut flush directly adjacent to the locking tab to prevent sharp protrusions.

9.10.6.3 Protecting Cables Within Racks and Cabinets

- Where cables or conductors are routed through holes in metallic surfaces or near sharp edges, the sharp surfaces **shall** be suitably protected with a grommet or similar material to help protect the cable or conductor from damage caused by sharp edges.
- Ensure cables are not crimped or bent when cabinet doors are opened or closed.

9.10.6.4 Cable Bending Radius Within Racks and Cabinets

- The minimum inside bend radius for twisted-pair cables **shall** be four times the cable diameter or as otherwise required by the cable manufacturer (see TIA-568-C for additional information).
- The minimum inside bend radius for shielded twisted-pair cables **shall** be eight times the cable diameter or as otherwise required by the cable manufacturer (see TIA-568-C for additional information).
- The minimum inside bend radius for a patch cord **shall** be one times the cable diameter.
- See “Network Cable Bending Radius” on page 9-49 for computer network cable bending radius requirements.
- See “Optical Fiber Cabling Bending Radius” on page 9-54 for optical fiber bending radius requirements.
- The minimum inside bending radius of E1/T1 cables **shall** follow the requirements for computer network cables described in “Network Cable Bending Radius” on page 9-49 or as required by the cable manufacturer.
- All other cables **shall not** have sharp bends which will damage or degrade the performance of the cable. The cable manufacturer's specifications **shall** be followed.
- Grounding conductors of all sizes **shall** maintain a minimum bending radius of 203 mm (8 in.) as described in Chapter 5, “Internal Bonding and Grounding (Earthing)”.
- The inside bend radius for RF cables **shall** be as specified by the cable manufacturer. See “RF Cabling” on page 9-54.
- The minimum inside bend radius for equipment power cords **shall** be adequate to prevent damage to the cord. Power cords **shall** be installed in such a way to prevent kinking and/or pinching.

9.10.6.5 Cable Separation and Grouping Within Racks and Cabinets

- Cabling in racks or cabinets **shall** be grouped according to function. Groups are defined as:
 - AC power cords
 - DC power cables
 - Grounding conductors
 - RF transmission cabling
 - Data, control, signal and timing reference cabling and telephone cabling
- Cable groups within racks and cabinets **shall** be separated by 50.8 mm (2 in.) from other cable groups. See TIA-568-C and TIA-569-D; and NFPA 70-2017, Articles 800.133, 810.18, 820.133 and 830.133, for additional information.
- Where practicable, cable groups at or in close proximity to equipment chassis should be separated by 50.8 mm (2 in.) or cross at a 90 degree angle.
- Where practicable, cable groups of different types should maintain 50.8 mm (2 in.) separation where passing through a cabinet housing. Where the 50.8 mm (2 in.) separation cannot be maintained through the cabinet housing penetration, separation **shall** be maintained before and after the penetration point. See Figure 9-27 for an example. The right half of the figure illustrates cables of different groups passing through a penetration in the top of the cabinet and shows separation of cable groups before and after the penetration.

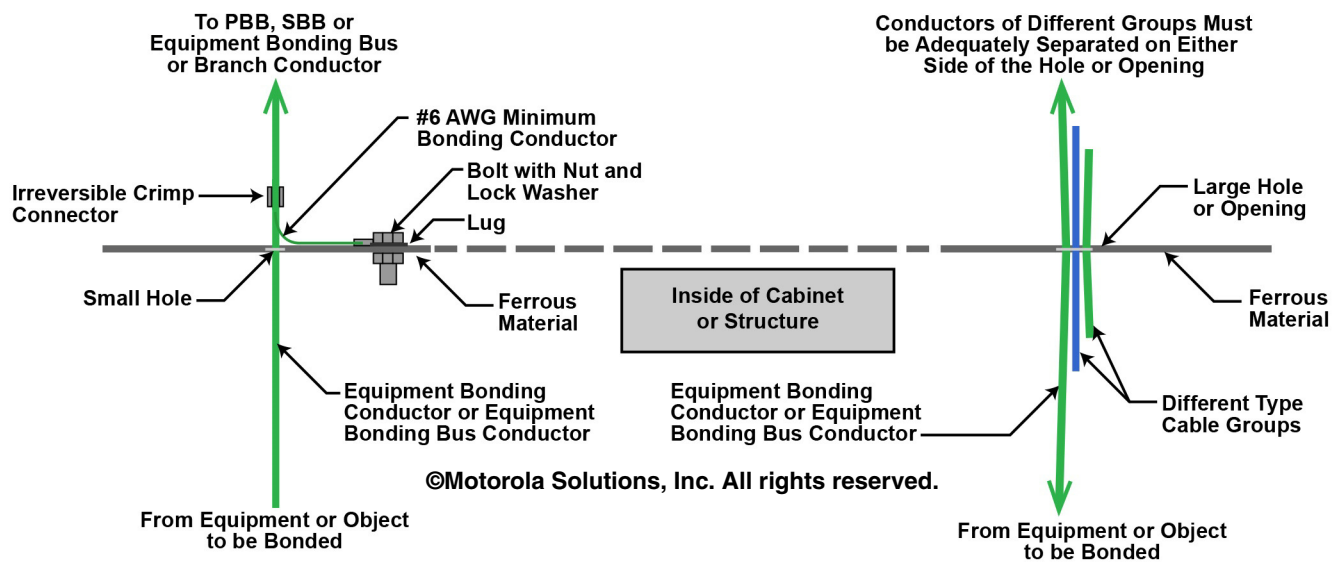

Figure 9-27 Conductor Routing Through Holes or Openings in Metallic Surfaces

9.10.7 AC Power Cabling

Facility AC wiring within junction boxes, receptacles and switches **shall** be performed by a qualified, licensed and bonded electrical contractor. Personnel safety and liability hazards can result from AC wiring performed by installation personnel other than an electrical contractor.

When an open equipment rack is used, hard wiring of power is not always practicable. Mounting a dedicated simplex receptacle or receptacle assembly on the rack may be the most convenient method of supplying power, especially if multiple pieces of equipment are mounted in the rack.

These receptacle assemblies can be manufactured in advance and mounted to the top face of an equipment rack. Mounting can also use a fabricated power pole mounted between racks.

Consumer-grade power outlet strips **shall not** be used in any installation under any circumstances. Extension cords of any type **shall not** be used for connecting line power to communications equipment.



CAUTION

Do not plug ancillary items into receptacles supporting communications equipment. Examples of ancillary equipment: Space heaters, microwave ovens, televisions, and so on.



Figure 9-28 Example of Rack Mounted Receptacle Assembly

9.10.8 DC Power Cabling

In telecommunications environments, common DC systems are as follows:

- +12 volt systems
- +24 volt systems
- -24 volt systems
- -48 volt systems

Traditional wireline telephone offices most often use -48V, sometimes called -BATT voltage, whereas many cellular, PCS and other radio systems use +24 to 27 V. There are also instances of -24V systems. In U.S. installations, the most common practice is to use red cabling for the sourcing, fused, ungrounded or “hot” terminal. Black cabling is used for the return, unfused, grounded, terminal. European installation practice uses blue insulation for the “hot” lead. Chapter 6, “Power Sources”, discusses power cabling sizing and other installation concerns. The manual for the equipment being installed also has specifications stating the cabling size required. Careful consideration must be given to cable size and length. See Chapter 6, “Power Sources”, for further information.

9.10.8.1 Cable Tray Installation Requirements

Requirements for installing DC power conductors and/or cables in a cable tray are as follows:

- Individual conductors **shall not** be installed directly in a cable tray. **EXCEPTION:** In industrial establishments, as determined by the Authority Having Jurisdiction (AHJ), single-conductor cables can be supported in a cable tray if they are 1/0 AWG or larger and marked on the outer surface for use in a cable tray (NFPA 70-2017, Article 392).
- DC power **cables** can be supported on the cable tray without additional protection if they are Tray Cable (TC) rated. TC rated cables are defined under NFPA 70-2017, Article 336.2, as “A factory assembly of two or more insulated conductors, with or without associated bare or covered grounding conductors, under a nonmetallic jacket.” See Figure 9-29.

- DC power **conductors** can be supported by a cable tray if they are installed in an approved raceway under the conditions described in their respective articles and sections. Approved nonmetallic raceways may include, but are not limited to, the following:
 - Rigid Polyvinyl Chloride Conduit: Type PVC (NFPA 70-2017, Article 352).
 - Liquidtight Flexible Nonmetallic Conduit: Type LFNC (NFPA 70-2017, Article 356) for lengths not longer than 1.8 m (6 ft) or as otherwise allowed by the AHJ.
 - Nonmetallic Tubing: Type ENT (NFPA 70-2017, Article 362). See Figure 9-30.
 - Electrical Metallic Tubing: Type EMT (NFPA 70-2017, Article 358).



©Motorola Solutions, Inc. All rights reserved.

Figure 9-29 Examples of TC Rated DC Cabling



©Motorola Solutions, Inc. All rights reserved.

Figure 9-30 DC Power Conductor Routed in ENT

9.10.9 Computer Network Cabling

Computer network cabling typically consists of category 5e (CAT 5e), category 6 (CAT 6) or category 6A (CAT 6A) cabling terminated with 8-pin modular connectors.

The proper installation of computer network cabling is critical to the safe and reliable operation of the computer network. It is recommended that standards developed by the Telecommunications Industry Association (TIA) or equivalent be followed. Applicable NFPA codes, local electrical codes, local building codes and other standards in this manual **shall** also be followed when installing computer network cabling.



NOTE

It is recommended that computer network cable installations be performed by a specialist in the installation of computer networks. The specialist should have the expertise, knowledge of applicable local codes and the test equipment required for a quality installation.

9.10.9.1 Computer Network Cable Types

Category 5e (CAT 5e), Category 6 (CAT 6) and Category 6A (CAT 6A) unshielded twisted pair (UTP), 100-ohm cables are the recommended cable types for computer network cabling and will be the assumed cable types throughout this section. See TIA-568-C for additional information.

Horizontal cabling is defined as that portion of the cabling system that extends from the work area outlet, through the cabling in the wall/ceiling/floor and then to the patch panel in the telecommunications room (see TIA-568-C and TIA-569-D).

Cable requirements are as follows:

- Horizontal cabling **shall** have solid conductors (TIA-568-C).
- Cables used to construct work area cords, equipment cords and patch cords should have **stranded** conductors (TIA-568-C).
- Shielded (screened) cables may be used in applications that require additional shielding. Where shielded cables are used, the shield **shall** be connected at both ends so the shield is continuous for the complete channel (TIA-568-C).





CAUTION

Installing a shielded cable between different buildings (inter-building) may create a dangerous ground loop condition and should be avoided where practicable. This is due to different electrical services and different grounding electrode systems. Interrupting the cable shield at one end (see “Telecommunication Cable Metallic Shields” on page 5-122) or in the middle within a handhold is recommended. Consultation with Motorola Solutions Engineering or other engineering firm is recommended in these applications.

9.10.9.2 Connecting Hardware

Unshielded twisted pair (UTP) cables **shall** be terminated with connecting hardware of the same category rating or higher. This includes all connectors, punch blocks, cross-connect jumpers and patch cords. It is recommended that hardware used to terminate cables be of the insulation displacement (IDC) type. Modular connectors **shall** also be of the proper type for the cable used; solid conductor cable may use a different connector than stranded cable. See TIA-568-C for additional information.

Connecting hardware should be marked to designate transmission performance at the discretion of the manufacturer or the approval agency. The markings, if any, **shall** be visible during installation. It is suggested that such markings consist of the following:

- “CAT 5e” or  for category 5e components.
- “CAT 6” or  for category 6 components.
- “CAT 6A” or  for category 6A components.



NOTE

Performance markings are in addition to, and do not replace, other markings required by listing agencies or those needed to satisfy electrical code or local building code requirements.

9.10.9.3 Cable and Connector Wiring

Appropriate color-coding and jack pair assignments **shall** be followed when wiring modular jacks, connectors and cables. The same wiring standard should be used throughout the cabling system. TIA T568A and T568B are the recommended standards. Figure 9-31 shows the color coding and end view of an 8-pin modular female jack for both standards with the pairs and colors identified. See TIA-568-C for additional information.

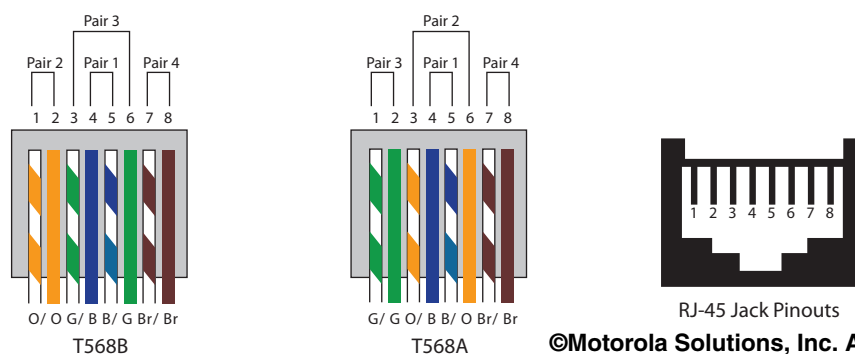

©Motorola Solutions, Inc. All rights reserved.

Figure 9-31 RJ-45 Color Coding



NOTE

A cross-over cable has one end wired as T568B and the other end wired as T568A.

9.10.9.4 Network Cable Connector Installation

The proper construction of network cables is important to the operation of not only traditional networks, but network based communications systems as well. This section contains the procedure steps to be used for one connector manufacturer. Although the exact procedure for each brand of connector may vary, the end results should be the same. The connectors and tools for this example are for the EZ RJ45[®] connector.



IMPORTANT

Shielded connectors shall be used on shielded cables.

Using the correct tools for the job is critical to the integrity of the finished product. Figure 9-32 shows the tools and components required for this procedure:

- Connector manufacturer specified ratcheting-crimper for the connector being used.
- Wire Stripper for removing the outer cable jacket.
- Flush cut wire cutter.
- Screwdriver used for straightening the wires.
- Connectors.
- Connector boots.

©Motorola Solutions, Inc. All rights reserved.



Figure 9-32 Tools for Network Cable Connector Installation

1. Install the boot on the cable.



2. Strip the cable to the appropriate length for the connector being used. Using a cable stripper ensures a uniform cut that does not damage the wires and gives a clean cut so it will fit inside the connector properly.



3. Cut the cellophane filler strip flush with the cable jacket.



4. Separate the wire pairs in the following order: orange, green, blue, brown. This step makes it easier to separate the wires and keep them in the proper order.

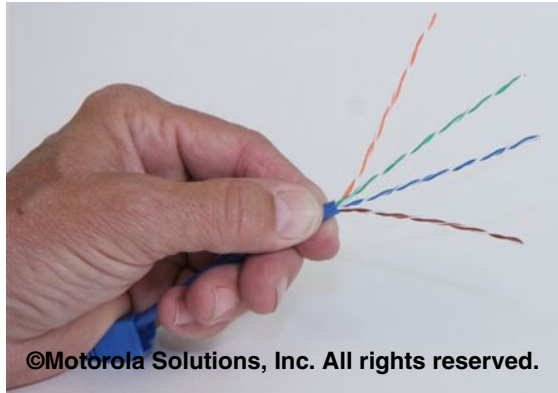

5. Untwist the pairs.

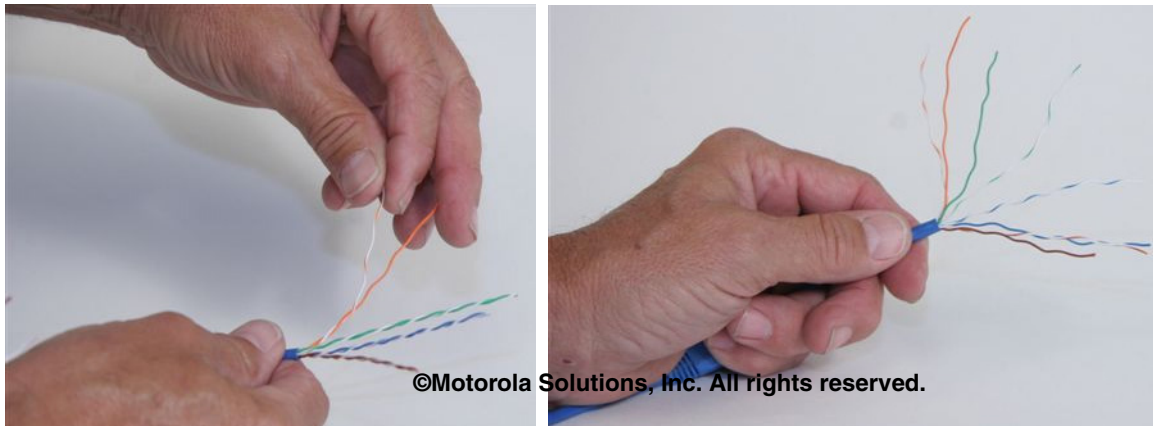

6. Straighten the pairs using a screw driver or other similar tool.

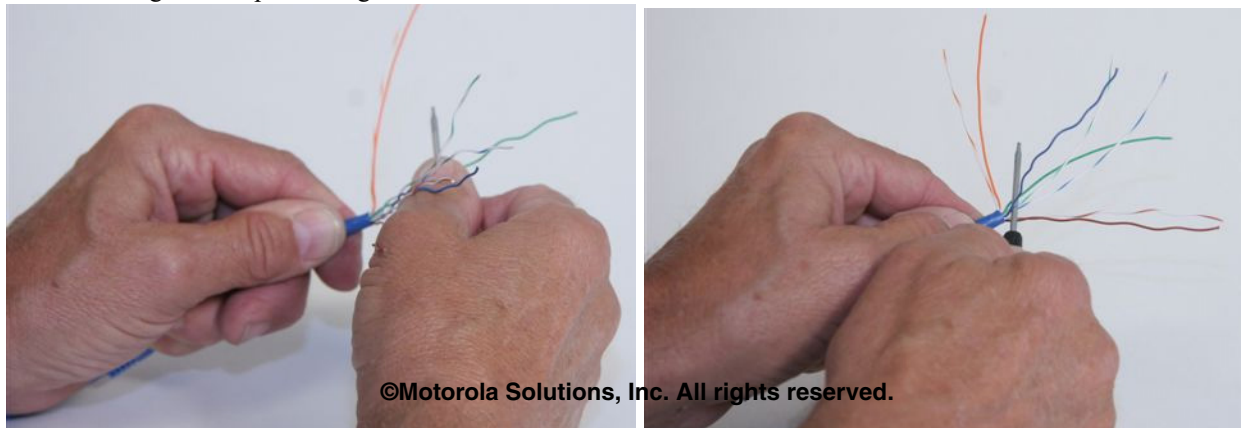

7. Position the pairs in the following order.

Order	TIA568B	TIA568A
1	White/Orange	White/Green
2	Orange	Green
3	White/Green	White/Orange
4	Blue	Blue
5	White/Blue	White/Blue
6	Green	Orange
7	White/Brown	White/Brown
8	Brown	Brown



8. Cut the ends of the separated wires at an angle, which allows for easier insertion of the wires into the EZ-RJ45[®] connector. Other style connectors may require a variation of this method.

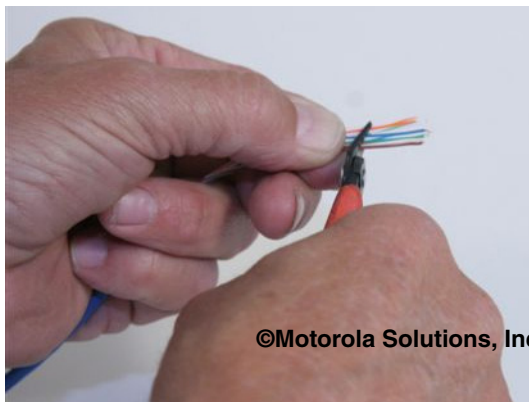

9. Insert the wires in the connector and confirm the order of the wires.



10. Pull wires securely into the connector. You should see the cable jacket well inside the base of the connector.



11. Once you have reconfirmed the wires are in correctly, inset the connector into the crimp tool.



12. With the connector firmly seated in the tool, crimp the connector in place. The tool should cut the wires flush with the connector.



**IMPORTANT**

Do not crimp the connector beyond the tool ratcheting point. Over-crimping beyond this point may result in a poor connection.

13. Inspect the connector.



14. Slide the boot in place.



9.10.9.5 Network Cable Installation and Routing

Observe the following installation and routing requirements for computer network cabling in addition to the general requirements throughout the rest of this manual:

- Network cabling **shall** be installed in a neat and workmanlike manner (NFPA 70-2017, Articles 725.24 and 800.24).
- Consideration should be given to using some method of cable management and containment for network cables. Such methods can be dedicated cable runs, lay-in wire-ways, cable trays and conduits. See TIA-569-D for additional information. See Figure 9-33 for an example.
- Network cables **shall not** be installed in the same conduit, cable tray, outlet box or similar device with AC power cables, unless separated by a permanent barrier (such as a metallic conduit) or listed divider. Doing so can be unsafe and is likely to cause EMI onto the network cable, causing network errors. See NFPA 70-2017, Article 800.133; TIA-568-C and TIA-569-D, for additional information. See Figure 9-34 for an example.

©Motorola Solutions, Inc. All rights reserved.

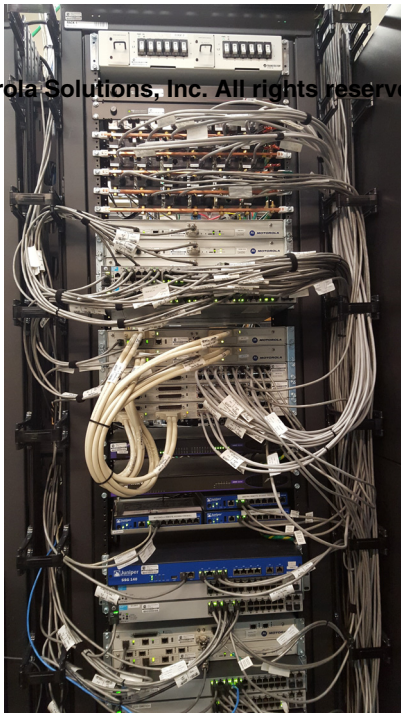

Figure 9-33 Cable Management System

©Motorola Solutions, Inc. All rights reserved.

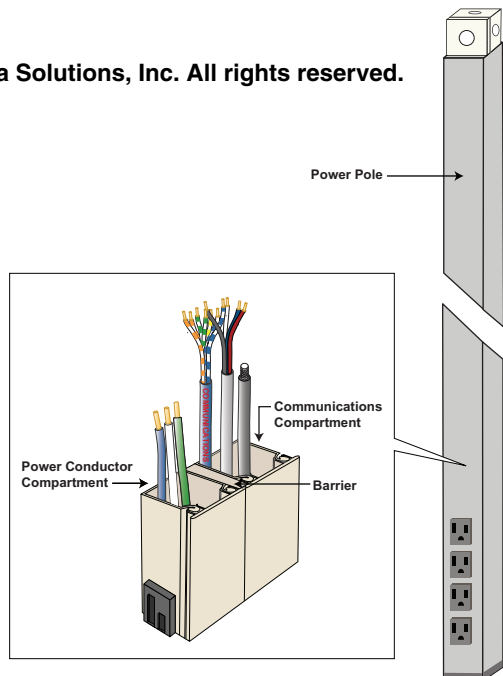

Figure 9-34 Cables in Conduit with Barrier

- Network cables **shall not** be laid directly on the tiles of a false ceiling. See Figure 9-35 for an example of routing cables in a suspended ceiling. See TIA-569-D and NFPA 70-2017, Articles 725.21 and 800.21, for additional information.

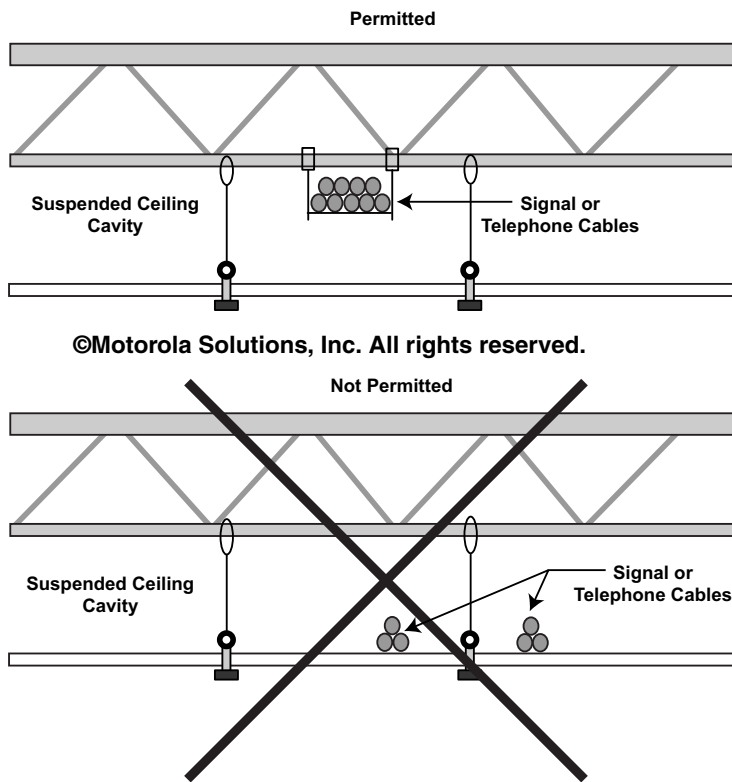

Figure 9-35 Routing Cables in a Suspended Ceiling

- Avoid routing network cables near sources of Electromagnetic Interference (EMI) and Radio Frequency Interference (RFI). Routing cables near sources of EMI or RFI can cause data errors and degraded system performance. Such noise sources include, but are not limited to, the following: electrical power wiring, electrical transformers, dimmer switches, radio frequency transmitters, motors, generators and fluorescent lights.
- If routing network cables near sources of EMI or RFI cannot be avoided, reasonable precautions **shall** be taken to minimize the EMI or RFI negative impact. Such precautions may include the following: increasing the physical distance between the network cable and the source of the EMI/RFI, installing a CAT6 or CAT6A instead of a CAT5e, installing the network cable inside a grounded metallic conduit or use of a shielded network cable (screened twisted pair cable). See TIA-568-C and TIA-569-D for additional information.
- Avoid parallel paths between power and telecommunications cables (TIA-569-D, section B.5).
- See Table 9-2 for the minimum separation distance between computer network cabling (UTP/STP) and power cables.
- Network cables **shall not** be run from one building to another building without proper grounding and surge suppression techniques. Computer network cabling entering and/or leaving a building **shall** be properly grounded and protected from surges as required elsewhere in this manual. Consultation with Motorola Solutions Engineering is recommended in these applications. See Chapter 7, “Surge Protective Devices”.



CAUTION

Installing a shielded cable between different buildings (inter-building) may create a dangerous ground loop condition and should be avoided where practicable. This is due to different electrical services and different grounding electrode systems. Interrupting the cable shield at one end (see “Telecommunication Cable Metallic Shields” on page 5-122) or in the middle within a handhold is recommended. Consultation with Motorola Solutions Engineering or other engineering firm is recommended in these applications.

Table 9-2 MINIMUM SEPARATION DISTANCE BETWEEN COMPUTER NETWORK CABLING (UTP/STP) AND POWER CABLES

Power Circuit Type (50/60 Hz) or Electric Device	Minimum Required Separation ²	Notes
120/240 VAC, 20 A 1 ϕ		Based on all circuit conductors routed together and enclosed in a grounded, metallic conduit.
Up to 30 circuits	50 mm (2 in.)	
31 to 60 circuits	100 mm (4 in.)	
61 to 90 circuits	150 mm (6 in.)	
91 or more circuits	300 mm (12 in.)	
120/240 VAC, 32 A 1 ϕ		Based on all circuit conductors routed together and enclosed in a grounded, metallic conduit.
Up to 9 circuits	50 mm (2 in.)	
10 to 19 circuits	100 mm (4 in.)	
20 to 28 circuits	150 mm (6 in.)	
29 or more circuits	300 mm (12 in.)	
120/240 VAC, 63 A 1 ϕ		Based on all circuit conductors routed together and enclosed in a grounded, metallic conduit.
Up to 3 circuits	50 mm (2 in.)	
4 to 8 circuits	100 mm (4 in.)	
9 to 14 circuits	150 mm (6 in.)	
15 or more circuits	300 mm (12 in.)	
480 VAC, 100 A 3 ϕ		Based on all circuit conductors routed together and enclosed in a grounded, metallic conduit.
1 circuit	300 mm (12 in.)	
2 or more circuits	600 mm (24 in.)	
Fluorescent Lighting	125 mm (5 in.)	See TIA-569-D, section 9.3.2.
Electric Motors	122 cm (48 in.)	Suggested best practice.
Transformers	122 cm (48 in.)	Suggested best practice.
NOTES:		
1. Chart based on NFPA 70-2017 (various articles) and TIA-569-D, Table 6		
2. Separation distance may be cut in half if the UTP/STP cable is installed in a separate, grounded conduit.		
3. Avoid parallel paths between power and telecommunications cables (TIA-569-D, section B.5).		

9.10.9.6 Installation In Plenums, Air Handling Spaces and Risers

The following **shall** be followed when installing computer network cabling in plenums, air handling spaces and risers:

- See “Communications Cabling Requirements for Plenums and Other Spaces Used for Environmental Air” on page 9-26 for cable installation requirements in these spaces.
- See “Communications Cabling Requirements for Risers” on page 9-29 for cable installation requirements in these spaces.

9.10.9.7 Network Cable Installation Practices

Observe the following installation practices for computer network cabling in addition to other requirements throughout this chapter:

- Avoid unnecessary junction points and cross-connects. Every added junction point and cross-connect can decrease the performance of the network.
- Multiple appearances of the same cable at different locations, referred to as bridge taps, **shall** be avoided (see Figure 9-36). Each cable segment **shall** have only one source and one destination.
- Never untwist the twisted pairs of a network cable beyond 12.7 mm (0.5 in.) from the point of termination. Untwisting the wires can decrease the cable's category performance rating and degrade system performance. See TIA-568-C for additional information.
- Do not pull a network cable using a force greater than 110 Newtons (25 lb-force) or as recommended by the cable manufacturer (see TIA-569-D, section 5.3.1). Pulling a cable with too much force can negatively impact the cable's electrical characteristics and degrade its performance. See TIA-568-C for additional information.
- Do not over-tighten network cables with cable ties or other supports. Over-tightening cable ties or other supports can negatively impact the electrical characteristics of the cable and degrade the system performance. Velcro[®]-style cable ties are recommended. See TIA-568-C for additional information.
- Due to performance and testing requirements, it is recommended that modular cords be factory manufactured (TIA-568-C).

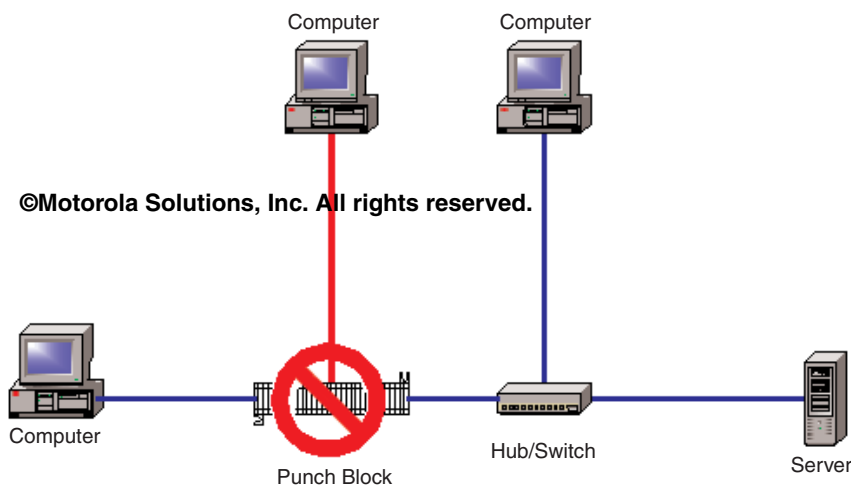

Figure 9-36 Disallowed Bridge-Tap Connection



IMPORTANT

Velcro[®]-style cable ties are recommended for securing computer network and E1/T1 cables. Velcro[®]-style cable ties prevent cable damage that could normally occur from over tightening a standard cable tie.

9.10.9.8 Network Cable Bending Radius

Sharp bends **shall** be avoided on computer network cables. Sharp bends can negatively impact the electrical characteristics of the cable and degrade system performance. See TIA-568-C and TIA-569-D for additional information. Observe the following computer network cable bending radius requirements:

- The minimum inside bend radius for a network cable **shall** be four times the cable diameter.
- The minimum inside bend radius for a shielded (screened) network cable **shall** be eight times the cable diameter.
- The minimum inside bend radius for a patch cord **shall** be one times the cable diameter.

9.10.9.9 Computer Network Topology

Computer network cabling **shall** utilize a “Star” topology, unless the specific design of the network calls for a different topology. Figure 9-37 shows a star topology example. See TIA/EIA-568-C for additional information.

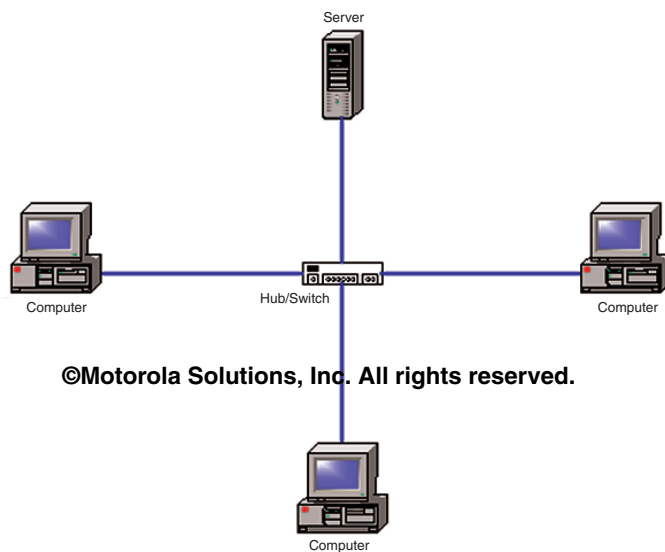

Figure 9-37 Star Network Topology

Computer network cable segment lengths **shall not** exceed 100 m (328 ft). This includes 90 m (295 ft) of building cabling and up to 10 m (32.8 ft) of equipment cords, cross-connects and patch cords. Of the 10 m (32.8 ft) allowed for equipment cords, cross-connects and patch cords, a maximum of 5 m (16 ft) should be used from the computer workstation to the information outlet. See TIA-568-C for more details. Figure 9-38 shows the maximum cabling lengths between various network elements.

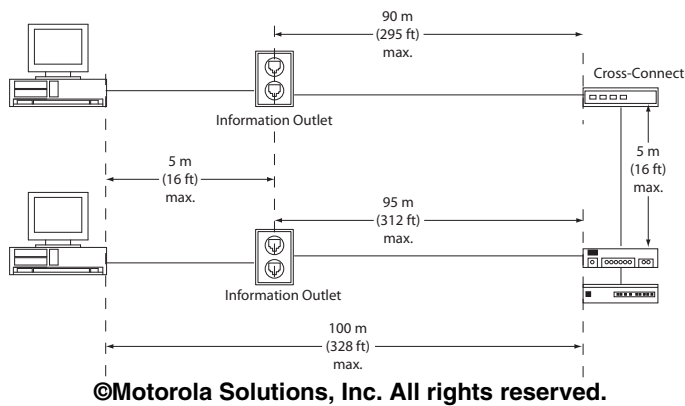

Figure 9-38 Network Segment Length Limits

For simplifying installation and reducing cable runs, a single computer network cable may be run from the equipment room hub/switch to an additional hub/switch in the computer workstation area for distribution to the individual computers (if approved by the System Engineer). This can reduce the number of cables required between the equipment room and the individual computers. Figure 9-39 shows an example of a single cable run. See TIA-568-C for additional information.

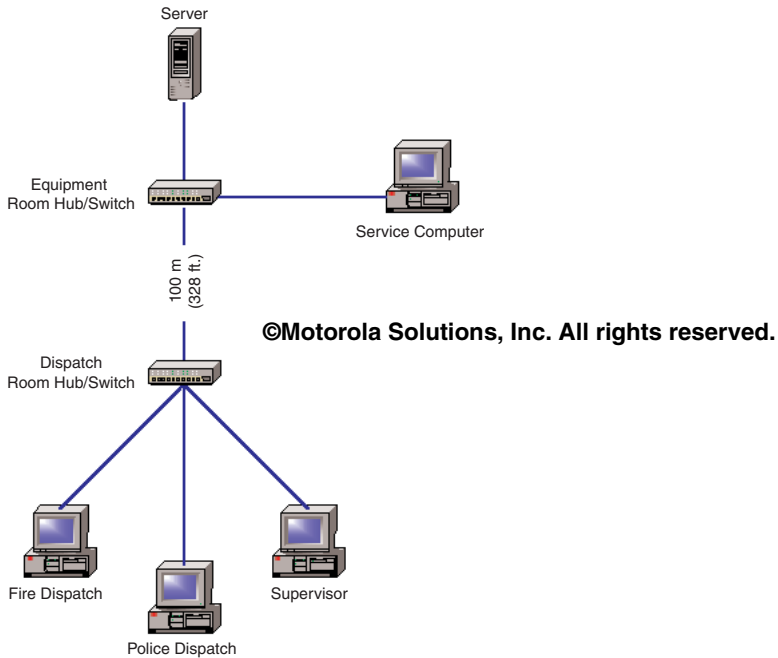

Figure 9-39 Hub/Switch Connected Network Segments

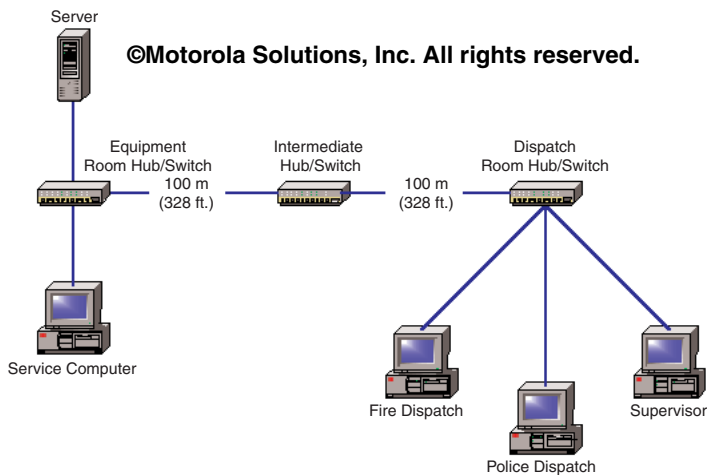

Figure 9-40 Additional Hub/Switch Used for Distances Greater Than 100 m



IMPORTANT

The use of additional intermediate hubs/switches shall be approved by the system engineer.

9.10.9.10 Bonding and Grounding

- Bonding and grounding of network devices **shall** comply with Chapter 5, “Internal Bonding and Grounding (Earthing)”.
- The shields of shielded 8-position modular connectors (plugs and jacks) **shall** be designed to ensure shield continuity when mated (TIA-568-C).
- Shielded computer network cables **shall** utilize an appropriate shielded connector on both ends of the cable so the shield is continuous for the complete channel (see TIA-568-C).

9.10.9.11 Labeling

Cables **shall** be labeled at both ends and at any pull boxes or junctions as described in “Cable Labeling” on page 9-62.

See TIA-606-B for detailed labeling guidelines.

9.10.9.12 Network Cabling Testing and Certification

Every effort should be made to ensure a quality installation of the computer network cabling system. Even the best installation effort cannot guarantee a properly working system. It is therefore required that computer network cabling systems be tested for proper performance.

Certification is the process of comparing the transmission performance of an installed cabling system to a standard, using a standard defined method of measuring the performance. Certification of the cabling system demonstrates component quality and installation workmanship. The network cable testing requirements are documented in TIA-568-C and ISO/IEC 11801 and **shall** be used as the basis for this testing. A cable tester designed for TIA-568-C or ISO/IEC 11801 certification **shall** be used. A cable tester with automated certification tests with a pass/fail indication is recommended. See Figure 9-41 for an example.



Figure 9-41 Network Cable Testing Example

Typical TIA-568-C and ISO/IEC 11801 test parameters that **shall** be performed to assure a properly working system are as follows:

- Wire Map
- Resistance
- Length
- Propagation Delay
- Delay Skew
- Insertion Loss (IL)
- Return Loss (RL)
- Near End Crosstalk (NEXT)
- Attenuation to Crosstalk Ratio
- Alien Crosstalk

9.10.10 Optical Fiber Cabling



WARNING

Never look into an optical fiber cable. Optical fiber cables use invisible laser light that is dangerous and can cause damage to the eye.

Optical fiber cables are grouped into three general categories as described in the following subsections (see NFPA 70-2017, Article 770.2, for additional information):

- Non-conductive: These cables contain no conductive materials.
- Conductive: These cables contain non-current-carrying conductive members, such as metallic strength members, metallic vapor barriers, and metallic armor or sheath.
- Composite: These cables contain optical fibers and current-carrying electrical conductors. These cables may also contain non-current-carrying conductive members, such as metallic strength members and metallic vapor barriers.

9.10.10.1 Optical Fiber Cabling General Requirements

Observe the following general requirements for the installation of optical fiber cabling:

- Optical fiber cables **shall** be installed in a neat and workmanlike manner (NFPA 70-2017, Article 770.24).
- Optical fiber cable installations **shall** conform to TIA-568-C.
- Optical fiber cable manufacturer requirements **shall** be followed.
- Optical fiber cables **shall** be permitted to be installed in raceways, listed optical fiber raceways and listed communications raceways. See NFPA 70-2017, Article 770.110, for more information.
- Optical fiber cables **shall** be permitted in the same cable tray, enclosure or raceway, with conductor of any of the following (NFPA 70-2017, Article 770.133):
 - Communications circuits in compliance with Parts I and IV of NFPA 70-2017, Article 800.
 - Community antenna television and radio distribution systems in compliance with Parts I and IV of NFPA 70-2017, Article 820.
 - Low-power network-powered broadband communications circuits in compliance with Parts I and IV of NFPA 70-2017, Article 830.
 - Class 2 and Class 3 remote-control, signaling and power-limited circuits in compliance with Parts I and II of NFPA 70-2017, Article 725.

- Power-limited fire alarm systems in compliance with Parts I and II of NFPA 70-2017, Article 760.
- Optical fiber cables **shall** be supported in such a manner that the cable will not be damaged by normal use of the building (NFPA 70-2017, Article 770.24).
- Optical fiber cables **shall not** be installed in a way that it prevents access to electrical equipment and removal of panels, including suspended ceiling panels (NFPA 70-2017, Article 770.21). See Figure 9-43.
- Where optical fiber cabling is used, the cable **shall** be labeled to distinguish it from electrical signal cabling (see Figure 9-42).
- Other applicable requirements of this chapter **shall** be observed.



Colored Armor



Label

©Motorola Solutions, Inc. All rights reserved.

Figure 9-42 Fiber-Optic Cable Identification

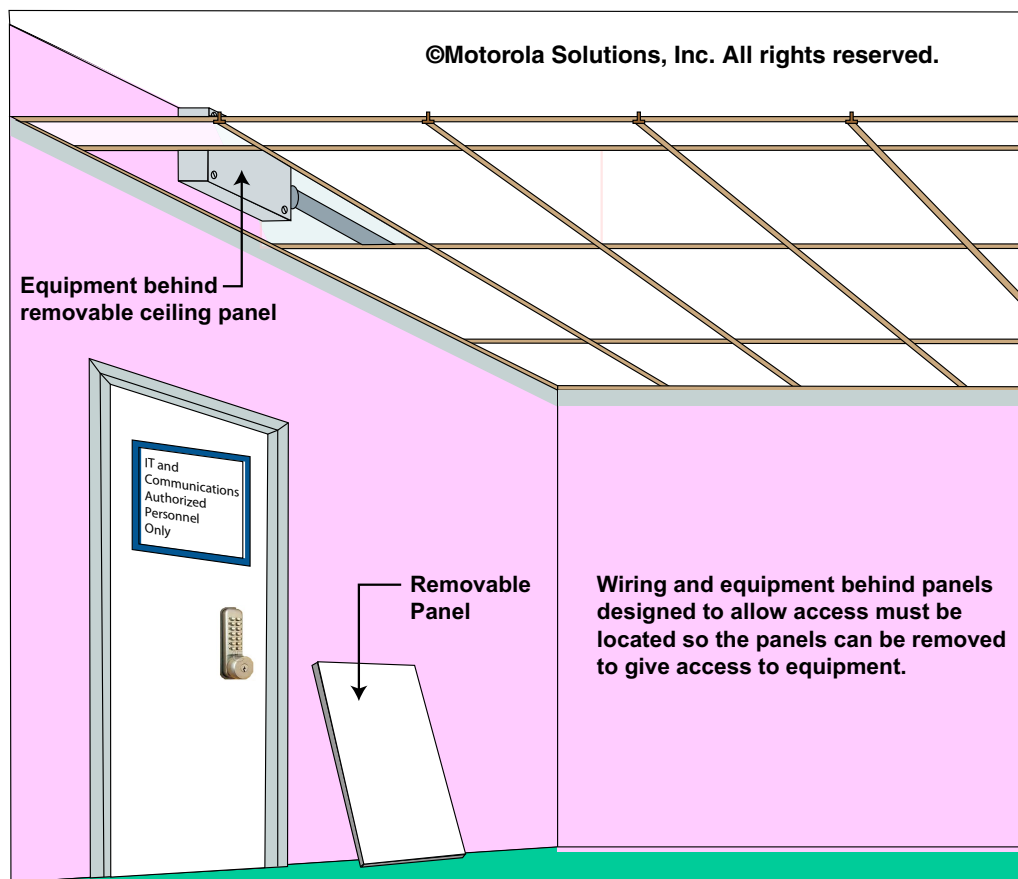

Figure 9-43 Panels Designed to Allow Access to Cabling

9.10.10.2 Optical Fiber Cabling Bending Radius

Sharp bends **shall** be avoided on optical fiber cables. Sharp bends can negatively impact the optical characteristics of the cable and degrade system performance. The minimum inside bending radius for an optical fiber cable **shall** be 10 times the outside diameter of the optical fiber cable or as otherwise required by the cable manufacturer (TIA-568-C).

9.10.10.3 Optical Fiber Cable Installation In Plenums, Air Handling Spaces and Risers

The following **shall** be adhered to when installing optical fiber cabling in plenums, air handling spaces and risers.

- See “Communications Cabling Requirements for Plenums and Other Spaces Used for Environmental Air” on page 9-26 for cable installation requirements in these spaces.
- See “Communications Cabling Requirements for Risers” on page 9-29 for cable installation requirements in these spaces.

9.10.10.4 Conductive Optical Fiber Cabling Requirements

The following requirements apply specifically to conductive optical fiber cabling. These requirements are in addition to other requirements in this section.

- The non-current-carrying metallic members of optical fiber cables entering buildings **shall** be grounded as close to the point of entrance as practicable or **shall** be interrupted as close to the point of entrance as practicable by an insulating joint or equivalent device (NFPA 70-2017, Articles 770.93 and 770.100). See “External Ground Bus Bar” on page 4-43.
- Conductive optical fiber cables **shall not** be permitted to occupy the same cable tray or raceway with conductors for electric light, power, Class 1, non-power-limited fire alarm, Type ITC or medium-power network-powered broadband communications circuits (NFPA 70-2017, Article 770.133).

9.10.10.5 Non-Conductive Optical Fiber Cabling Requirements

The following requirements apply specifically to non-conductive optical fiber cabling. These requirements are in addition to other requirements in this section.

- Non-conductive optical fiber cable **shall** be permitted to occupy the same cable runway or raceway with conductors for electric light, power, Class 1, non-power-limited fire alarm, Type ITC or medium power network-powered broadband communications circuits operating at 600 volts or less (NFPA 70-2017, Article 770.133).
- Non-conductive optical fiber cables **shall not** occupy the same cabinet, outlet box, panel or similar enclosure housing the electrical terminations of an electric light, power, Class 1, non-power-limited fire alarm or medium power network-powered broadband communications circuit (NFPA 70-2017, Article 770.133). The following exceptions apply:
 - Unless the optical fiber cable is functionally associated with the other circuits.
 - Where the optical fiber cable is installed in factory or field assembled control centers.
 - Where the optical fiber cable is separated from the other circuit conductors by a permanent barrier or listed divider.
 - In industrial establishments (see NFPA 70-2017, Article 770.133, Exceptions 3 and 4, for more details).

9.10.10.6 Composite Optical Fiber Cabling Requirements

Optical fibers in composite optical fiber cables containing only current-carrying conductors for electric light, power, Class 1 circuits rated 600 volts or less **shall** be permitted to occupy the same cabinet, cable tray, outlet box, panel, raceway or other termination enclosure with conductors for electric light, power or Class 1 circuits operating at 600 volts or less (NFPA 70-2017, Article 770.133).

9.10.11 RF Cabling

RF cabling typically consists of 6.35 mm (0.25 in.) or 12.5 mm (0.5 in.) coaxial cables of foam filled or super-flexible construction.

Manufacturer's specifications regarding bend radius **shall** be observed. Examples of typical RF cable bend radii are as follows:

Minimum bend radius for super-flexible cable sizes:

- 6.35 mm (0.25 in.) diameter cable: 25.5 mm (1 in.) bend radius
- 12.5 mm (0.5 in.) diameter cable: 31.7 mm (1.25 in.) bend radius

Minimum bend radius for foam-filled cable sizes:

- 12.5 mm (0.5 in.) diameter cable: 127 mm (5 in.) bend radius
- 22.2 mm (0.875 in.) diameter cable: 254 mm (10 in.) bend radius
- 31.7 mm (1.25 in.) diameter cable: 381 mm (15 in.) bend radius
- 41.3 mm (1.625 in.) diameter cable: 508 mm (20 in.) bend radius

**NOTE**

Consult manufacturer's specifications for the bending radius for the specific cable in use.

**CAUTION**

Sharp bends can negatively affect the impedance characteristics of a cable.

9.10.11.1 Securing RF Cables to Tower and Cable/Ice Bridge

Hangers are the hardware devices used to secure a cable to the tower. Hangers are required to properly secure cables to the tower. When installing coaxial cables, hangers designed for the specific type and size of cable **shall** be used.

The number and spacing of hangers for RF cabling **shall** conform to manufacturer's specifications.

Only hangers designed for the specific purpose **shall** be used. An insufficient number of hangers can result in cable damage.

Appropriate hanger hardware **shall** be used:

- The hanger **shall** be designed for use as a cable hanger
- The hanger **shall** be approved by the cable manufacturer
- Tie wraps **shall not** be used
- The proper size **shall** be used. Too small can damage the cable; too large may not provide adequate support

Hanger spacing is the maximum distance between hangers. Hanger spacing is tabulated as a function of wind speed and ice conditions, as well as cable and hanger types. Hanger spacing is specified by the cable/hanger manufacturer.

- Should be based on TIA-222 guidelines
- Cables installed outdoors **shall** be rated for use outdoors.

See “Grounding and Bonding of RF Transmission Lines and Other Communications Cables” on page 4-97 for RF cable grounding and bonding requirements.

9.10.11.2 RF Connectors

RF connector installation problems account for a majority of antenna system installation problems. Improperly installed connectors can result in return loss/VSWR problems and/or Passive Intermodulation (PIM) problems. RF connector installation requirements are as follows:

- Installer **shall** be properly trained. Training and certification from the cable/connector manufacturer is preferred.
- Connectors designed for the specific type of cable in use **shall** be used.
- Connectors that are designed to be assembled without the need for torque wrenches are preferred. These connectors still require torque wrenches to be used when coupling to other connectors.

- Prior to connection of the assembly to the cable, the inside of the connector **shall** be cleaned, dried and inspected as follows (see Figure 9-44):
 1. Cleaned with a lint free, self-saturating, foam-tipped alcohol swab (isopropyl 91% minimum).
 2. Dried using inert, compressed gas.
 3. Inspected under magnification for foreign debris.
 4. Repeated as needed to remove all foreign debris.



Figure 9-44 Examples of Connector Installation Cleaning Supplies

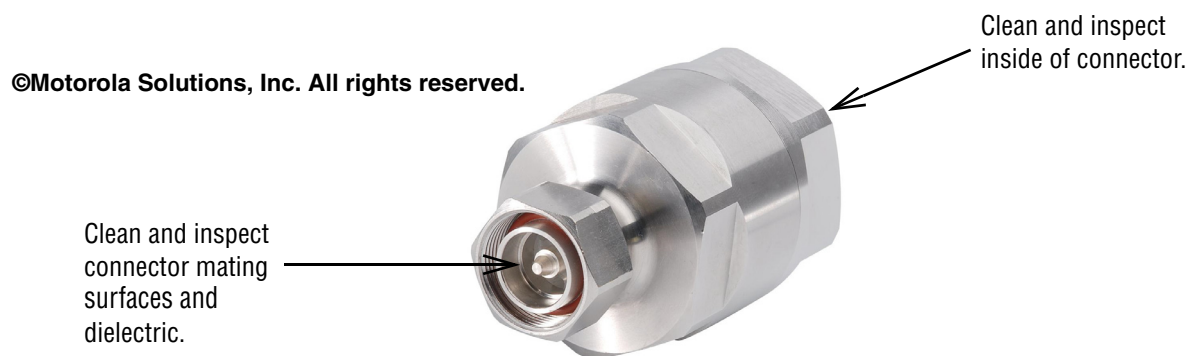

Figure 9-45 Example of Connector

- Prior to connection of the assembly to the cable, the cable dielectric **shall** be inspected under magnification for foreign debris and cleaned as necessary with a non-metallic, soft bristle brush and/or compressed inert gas (or other appropriate tool) (see Figure 9-44).
- Prior to coupling of connectors, the connector mating surfaces **shall** be cleaned, dried and inspected as follows (see Figure 9-44 and Figure 9-45):
 1. Cleaned with a lint free, self-saturating, foam-tipped alcohol swab (isopropyl 91% minimum).
 2. Dried using inert, compressed gas.
 3. Inspected under magnification for foreign debris.

4. Repeated as needed to remove all foreign debris.

**IMPORTANT**

Foreign debris in the connectors and/or cable dielectric can result in degraded return loss and/or PIM performance.

**NOTE**

The connector and/or cable manufacturer cleaning instructions may supersede the instructions given in this section.

9.10.11.2.1 Torque

Where specified by the manufacturer, connectors being assembled **shall** be tightened using a torque wrench.

Where specified by the manufacturer, connectors which are coupled together **shall** be tightened using torque wrenches.

**NOTE**

Specific connector torque wrenches are available from the connector manufacturers (see Figure 9-46).



©Motorola Solutions, Inc. All rights reserved.

Figure 9-46 Example of Connector Manufacturer Torque Wrench

**IMPORTANT**

Improper connector torque can result in degraded return loss and/or PIM performance.

9.10.11.2.2 Tools

Connectors **shall** be installed using the tools and methods specified by the manufacturer.

- The connector manufacturer cable preparation tool **shall** be used. The cable preparation tool **shall** be in good working order (clean and with sharp cutting surfaces) (see Figure 9-47).
- For Type N connectors, a center pin depth gauge **shall** be used (for non-fixed center pin).

**IMPORTANT**

Do NOT use a hacksaw for final cable length trimming. Using a hacksaw for final cable trimming can leave behind metal debris. Metal debris can cause return loss/Voltage Standing Wave Ratio (VSWR) and/or Passive Intermodulation (PIM) problems.



©Motorola Solutions, Inc. All rights reserved.

Figure 9-47 Example of Cable Preparation Tool

9.10.12 Antenna System Analysis (Antenna System Commissioning)

Antenna systems are a vital component to communications systems. Damaged or improperly installed antenna system can cause reduced communications capabilities and can, in turn, damage other system components. In order to confirm proper installation and antenna system component integrity, antenna systems **shall** be tested and verified with a Frequency Domain Reflectometer (FDR) at the time of installation.



NOTE

Antenna system analysis **shall** be performed by properly trained and certified individuals.

9.10.12.1 Analyzer and Test Requirements

Proper setup and configuration of the analyzer is critical for meaningful and accurate measurements. Configuration requirements for the analyzer and test equipment are as follows:

- Analyzer and precision load **shall** be in known good working order and serviced at the factory as recommended by the manufacturer.
- Analyzer **shall** be operated according to the manufacturer's requirements.
- Adapters **shall** be avoided whenever practicable. If adapters are needed, only precision adapters **shall** be used.
- When using a load, only a precision load **shall** be used.



IMPORTANT

The precision load is a very delicate piece of equipment and must be handled with care. Any drop or impact to the precision load can cause permanent internal damage.

- If an extension cable is needed, only a phase stable cable **shall** be used.
- Analyzer resolution **shall** be set to maximum for the highest quality and most accurate printouts.
- Antenna system analysis **shall** be performed on all antenna systems at the time of installation.
- Antenna system analysis should also be performed when connecting new equipment to existing transmission lines.

At a minimum, the following **shall** be performed on all newly installed antenna systems:

- Verify the antenna meets manufacturer's specifications for frequency and return loss.
- Verify system insertion loss: ensure all components meet manufacturer's specifications. For example, lightning suppressors, jumpers, connectors, main transmission line, and so on.
- System distance-to-fault test: ensure all system components meet distance-to-fault return loss specifications.
- Measure match (frequency vs. return loss test): ensure the antenna system meets the design specifications (typically supplied by the system engineer). Save this sweep for future comparison and troubleshooting purposes.

- System signature: perform a distance-to-fault measurement of the system at the operating frequency. Verify no anomalies. Save this sweep for future comparison and troubleshooting purposes.

9.10.13 Reuse of Existing RF Transmission Line

When replacing transmitters, receivers and transceivers, RF transmission lines may be reused. However, if the RF transmission line is near or past the manufacturer's suggested life span for the type of cable, it should be replaced. All tests specified in "Analyzer and Test Requirements" on page 9-58 should be performed on all reused RF transmission lines.

9.10.14 GPS Antenna Installation

The GPS antenna **shall** be mounted with an unobstructed view of the sky. A clear 360 degrees is preferred; however, blockage from buildings, trees or other objects should be less than 50%. Typically, the GPS antenna is mounted low and close to the roof of the equipment shelter or adjacent tower. This will help prevent the GPS antenna from sustaining a direct lightning hit. GPS antennas may be mounted on PVC masts.

A Surge Protective Device (SPD) **shall** be installed on the GPS antenna lead and any associated control or data cables within 61 cm (24 in.) of the entrance to the equipment room. If practicable, the GPS antenna should be located at least 13.7 m (45 ft) from towers, lightning rods or any other objects that are susceptible to lightning. The GPS antenna should be installed lower than any object susceptible to a lightning strike.



IMPORTANT

Redundant GPS antennas should be physically separated as much as practicable. This will help prevent both antennas from having the same signal obstructions at the same time. This may also help prevent physical damage to both antennas from falling tree limbs, and so on.

9.10.15 Cabling in Telephone Wiring Environments



NOTE

The following considerations apply only in cases where customer work must meet specifications stipulated by a telephone service provider. If no special stipulations are stated by the telephone service provider, best commercial practices such as Telcordia specifications may be used for telephony cabling within the communication site. When installing cabling that connects with telephone company assets or a demarcation point, inquire about any lacing requirements before work is performed.

9.10.15.1 Cabling Lacing Requirements

When installing a system for a telephone service provider or possibly other utility companies, special cabling methods such as cable lacing may be required. Observe the following considerations for cable lacing at a utility:

- Lacing of horizontal cables in cable trays should be performed every 914 mm (3 ft).
- Lacing of vertical cables to a cable ladder should be performed at every rung of the cable ladder. Any cable hanging between horizontal/vertical runways and racks cannot be unsupported for more than 610 mm (24 in.).



Figure 9-48 Example of Cable Lacing for a Utility

9.10.16 Distribution Frame Configurations

A distribution frame provides a centralized cross-connection point for audio, data, and alarm and control wiring between different pieces of equipment at a site and between the site and external lines. Distribution frames **shall** be implemented using one of the following methods:

- Distribution punch blocks affixed to a plywood panel that is mounted on a wall or a rack.
- Distribution punch blocks mounted on open-rack frames. These frames can be anchored to the floor.
- Typically, a distributed (as opposed to centralized) method is used. Pre-wired cross-connect panels (each one rack unit in height) distribute connections on a rack-by-rack basis.
- Cable management systems should be used.



Figure 9-49 Examples of Typical Distribution Frame

9.10.16.1 Distribution Frame Cross-Connect Wiring

- Distribution frame cross-connect wiring **shall** be performed in a neat and workmanlike manner (NFPA 70-2017, Article 800.24).
- Cross-connect wires for 66-blocks and 110-blocks **shall** be AWG #22 - #24 (0.644 mm - 0.511 mm) plastic-insulated solid copper wire.
- Individual wires for punch blocks **shall** enter the punch terminal from the top so that the wire tail points down after punch-down.
- CAT 3, 4, 5 or 6 data wiring **shall** enter punch terminals from the middle such that one wire points up while the other points down. In this manner, the cable twist that maintains the cable impedance stays intact. See Figure 9-50 for an example.
- The wiring **shall** dress down the source block column, across the bottom of the frame and up the destination block column. Approximately 50.8 mm (2 in.) of service loop at each end of the punched down wire **shall** be allowed.
- Wiring **shall** be properly secured using industry-standard methods as described in this chapter. Cable management systems are recommended.

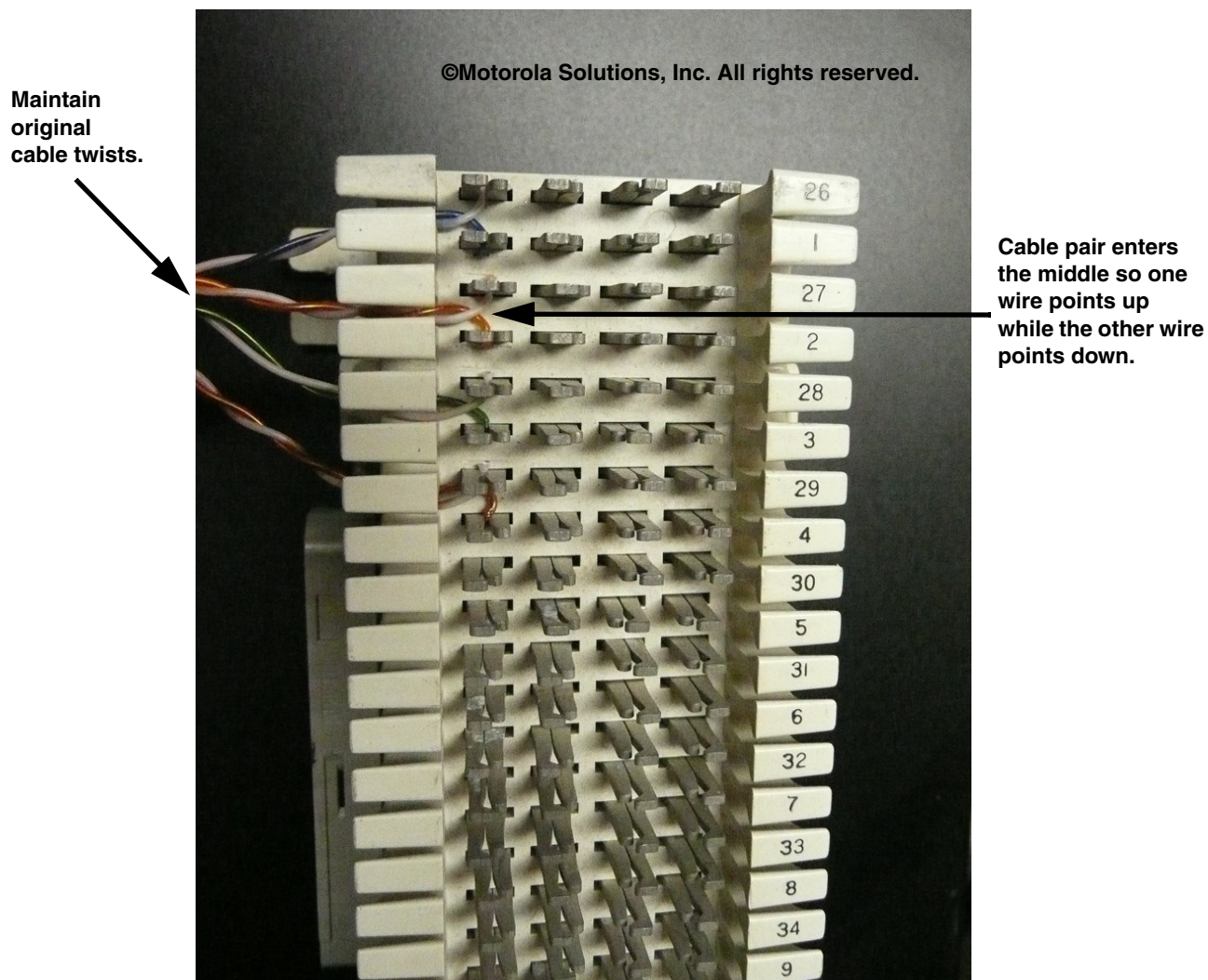

Figure 9-50 Example of Punch Blocks Used for Data

9.10.17 Cable Labeling

Cabling **shall** be identified with a standardized, double-ended system to facilitate cable and equipment connection identification. See TIA-606-B for additional information. Observe the following when devising a cable labeling system:

- Labeling **shall** identify the direction along the cable where terminating equipment is located.
- Labeling **shall** indicate the destination ends of the cable, including equipment name and connector reference designator or name. This applies to connectorized, lugged or punched down cable terminations regardless of the application (RF, audio or control).
- Labeling **shall** be imprinted on white opaque material (preferably plastic or plasticized paper) using indelible black ink.
- Label placement **shall** be between 101 to 152 mm (4 to 6 in.) from each end of the cable (or the most logical point that would allow the label to be easily read).
- Labeling should wrap entirely around the cable. It should be secure enough to assure label retention if cable is to be pulled through conduit.
- Information printed on each label should be brief but clearly understandable. Use industry-standard abbreviations, initials and acronyms to conserve label space. See Figure 9-51.
- Interior RF cables **shall** be labeled in the same manner as described previously.



Figure 9-51 Examples of Cable Labeling

9.10.17.0.1 Exterior Cable Labeling

Exterior cables (such as RF and data) **shall** use a means for permanent identification, such as stamped brass tags. Colored tape or tape bands may be used during installation, but are not considered permanent; therefore, do not meet the labeling requirements.



Figure 9-52 Examples of Interior and Exterior Cable Labeling

9.10.18 Outdoor Equipment/Cable Installation

9.10.18.1 Outdoor Equipment Cabinets

Equipment installed in an outdoor equipment cabinet (or similar) **shall** comply with all applicable requirements in this manual, including but not limited to the requirements described in:

- Chapter 4, “External Grounding (Earthing) and Bonding”
- Chapter 5, “Internal Bonding and Grounding (Earthing)”
- Chapter 7, “Surge Protective Devices”
- Appendix C, “Protecting Against Electrostatic Discharge in Equipment Rooms and Dispatch Centers”

9.10.18.2 Outdoor Cable Installation

The following outdoor cable installation requirements **shall** be observed:

- The antennas or lead-in conductors **shall not** be attached to the electric service mast. They **shall not** be attached to poles or similar structures carrying open electric light or power wires or trolley wires of over 250 volts between conductors. See Figure 9-53, Figure 9-54 and Figure 9-55 for examples.
- Outdoor antennas and lead-in conductors from an antenna to a building **shall not** cross over open conductors of electric light or power circuits and **shall** be kept well away from all such circuits so as to avoid the possibility of accidental contact.
- Where proximity to open electric light or power service conductors of less than 250 volts between conductors cannot be avoided, the installation **shall** be such as to provide a clearance of at least 600 mm (2 ft).
- Where practicable, antenna conductors **shall** be installed so as not to cross under open electric light or power conductors. See NFPA 70-2017, Article 810.13.
- See “Securing RF Cables to Tower and Cable/Ice Bridge” on page 9-55.

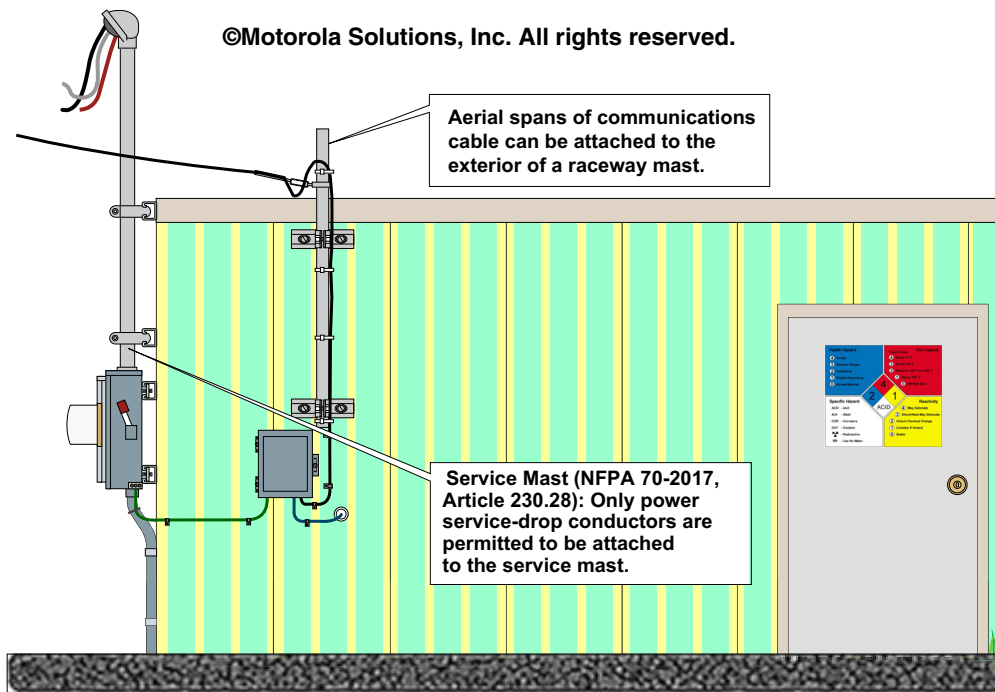

Figure 9-53 Example of Correct Installation of Outdoor Cables

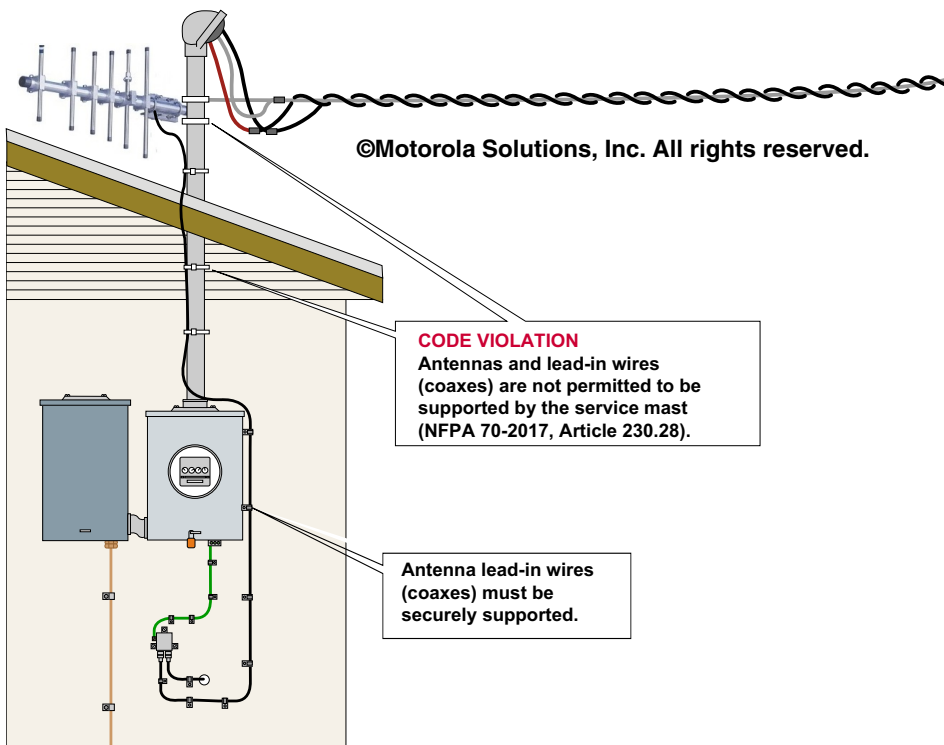

Figure 9-54 Example of Incorrect Installation of Outdoor Cables

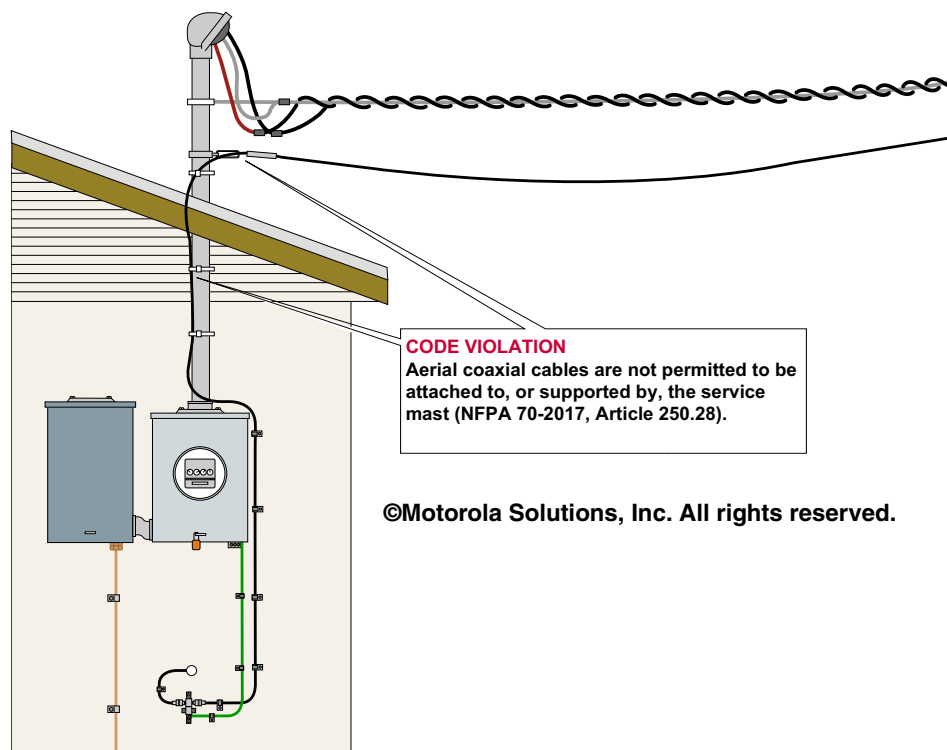

Figure 9-55 Example of Incorrect Installation of Outdoor Cables

9.10.18.3 Broadband Point-to-Point and Multi-point Wireless Links

See “Broadband Point-to-Point and Multi-point Wireless Links” on page 7-35 for information regarding these types of installations.

9.11 Tower Lighting Systems

The installation of tower lighting systems **shall** comply with the manufacturer instructions. The following **shall** be observed:

- External control boxes **shall** be bonded to the grounding electrode system as described in Chapter 4, “External Grounding (Earthing) and Bonding”.
- Internal control boxes **shall** be bonded as described in Chapter 5, “Internal Bonding and Grounding (Earthing)”.
- All conductors entering or exiting the shelter **shall** have appropriate surge protective devices (see Chapter 7, “Surge Protective Devices”).
- Cables installed on the tower **shall** be properly secured to the tower and cable/ice bridge using manufacturer approved hardware at the recommended intervals. See “Securing RF Cables to Tower and Cable/Ice Bridge” on page 9-55.

9.12 Equipment Removal

This section provides the workmanship requirements for equipment removal. The workmanship requirements in this section are general guidelines and are not all inclusive. See Telcordia GR-1275, section 20, for more information.

9.12.1 Equipment Removal Requirements

An inspection of the facility and equipment **shall** be made by a properly trained and certified site auditor and the project manager and/or site owner prior to the start of the removal activity. The purpose of the joint inspection is to disclose any potential hazards that may jeopardize personnel safety and/or equipment operation and maintenance. In addition, this inspection **shall** identify any unusual work conditions, additional work effort and/or additional or unique material items that may need to be addressed due to existing facility conditions.

Personnel safety and equipment protection are critical when work is to be performed on live power equipment and circuits.

- All equipment removal **shall** be performed by qualified personnel.
- See “Safety for Equipment Installation” on page 9-2.
- See “Installation Practices” on page 9-3.



NOTE

Equipment removal should not begin unless a minimum of two people are present. An exception is the removal of small, lightweight equipment. This is a safety precaution to ensure a timely response in the event of an accident.

- Adequate protection and insulation **shall** be placed on tools, bus bars, framework, and so on, when working on live equipment in order to prevent accidental short circuits.
- Conduits, outlet boxes and panels remaining in the removal area **shall** be supported and securely fastened.
- Open knockouts in AC service cabinets, conduit junction boxes, and so on **shall** be closed using approved caps.
- Open breaker locations in AC service cabinets **shall** be covered using approved caps.
- Conduit junction boxes and fittings remaining in the removal area **shall** be equipped with covers.
- Any AC conductors remaining after equipment removal (such as pig tails) **shall** be properly terminated in an enclosed location, such as a conduit junction box.
- All applicable safety precautions **shall** be adhered to during cable removal. Sharp objects **shall not** be used to separate cable bundles.
- All exposed floor obstructions or protrusions (for example, floor anchors, bolts, and so on) resulting from a removal **shall** be removed or cut flush with the floor covering.
- Building penetrations through floor and walls that are no longer used for cable, conduit, and so on **shall** be permanently sealed.

9.12.1.1 Equipment Protection During Removal

Removal personnel **shall** provide adequate protection for working equipment in the area of the removal activity. At the completion of the removal activity, all associated equipment protection **shall** be removed.

9.12.1.2 Grounding

All remaining equipment, cabling, racks, cabinets and ancillary equipment **shall** be grounded and bonded as specified in this manual. See “External Grounding (Earthing) and Bonding” on page 4-1 and “Internal Bonding and Grounding (Earthing)” on page 5-1.

9.13 Site Security Surveillance Systems

Site security surveillance systems are becoming more prominent at remote RF communications sites. These surveillance systems normally contain infrared motion detectors, cameras and recording devices. The video is typically streamed over a microwave or T1 link back to a central monitoring and dispatch center. See Figure 9-56 for an example of this type surveillance system at the remote RF site.



Figure 9-56 Site Security Surveillance System

Where a video surveillance system is installed at a communications site, the following installation requirements **shall** be met:

- All cabling penetrations into the building **shall** be properly sealed to prevent moisture and insect intrusion.
- Exterior routed cabling **shall** be securely attached to the structure and protected from damage. See Figure 9-57.
- All cabling **shall** meet minimum 51 mm (2 in.) cable group separation requirements throughout cable routing path to the interior equipment.
- All exterior routed sensor, video and power cabling **shall** be protected as specified in Chapter 7, “Surge Protective Devices”.
- All interior routed cabling **shall** be protected as specified in Chapter 7, “Surge Protective Devices”.



Figure 9-57 Securing and Protecting Surveillance Equipment Cabling

9.14 Utility Pole-Mounted Equipment Installation and Clearances

The following sections describe clearance requirements for utility pole mounted access points, wireless routers, point-to-point, external Surge Protective Devices (SPD) associated with the electronic equipment and similar devices. Before work can begin on a utility pole, written approval **shall** be received from the utility and/or Authority Having Jurisdiction (AHJ).



NOTE

This section is only meant to provide general guidance. Consultation with the National Electrical Safety Code[®] (NESC[®]), the utility pole owner and the Authority Having Jurisdiction is required for all installations.



WARNING

Installations on utility poles SHALL meet all installation and clearance requirements of the National Electrical Safety Code[®] (or equivalent), the electric utility (or utility that owns the pole) or other Authority Having Jurisdiction.



WARNING

High voltage hazards may exist with utility pole installations. Only properly trained and qualified personnel SHALL perform communications equipment installations and maintenance on utility poles and SHALL follow applicable OSHA regulations (or equivalent). Qualification and training SHALL be determined by the utility and/or Authority Having Jurisdiction.

9.14.1 Utility Pole Required Clearances

Installations on utility poles require careful coordination with the utility in order to ensure safe installations. Any communications equipment installed on a utility pole **shall** maintain clearances as required by the *National Electrical Safety Code[®]* (or equivalent), the utility owning the pole or other Authority Having Jurisdiction (AHJ).

In general, the following clearances **shall** be observed (*National Electrical Safety Code[®]*):

- Not less than 102 cm (40 in.) of vertical clearance between 7.2 kV phase-to-ground supply circuit equipment and the communications equipment (Figure 9-58). See NESC[®] Rule 238B.

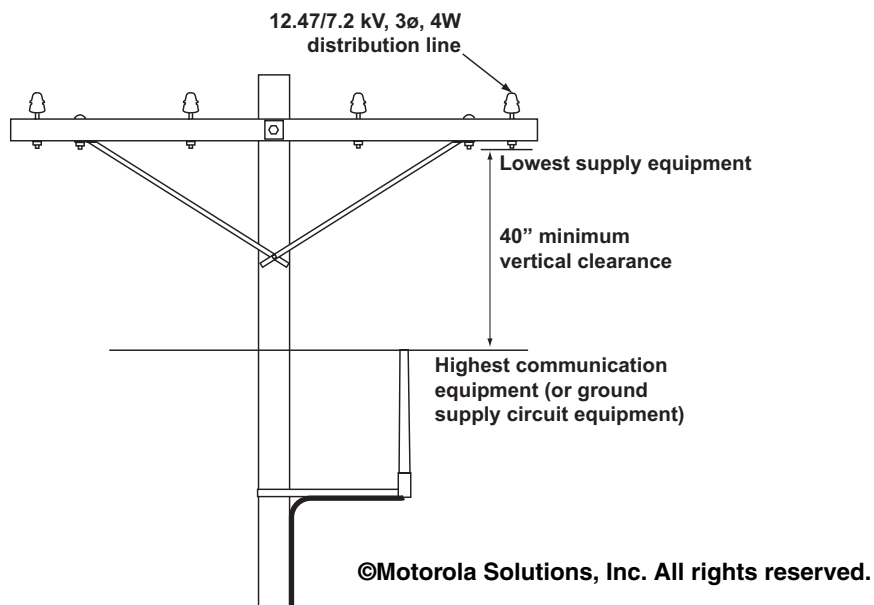

Figure 9-58 Supply to Communication Equipment Clearance - 7.2 kV Supply

- Not less than 109 cm (43 in.) of vertical clearance between 14.4 kV phase-to-ground supply circuit equipment and the communications equipment (Figure 9-59). See NESC[®] Rule 238B.

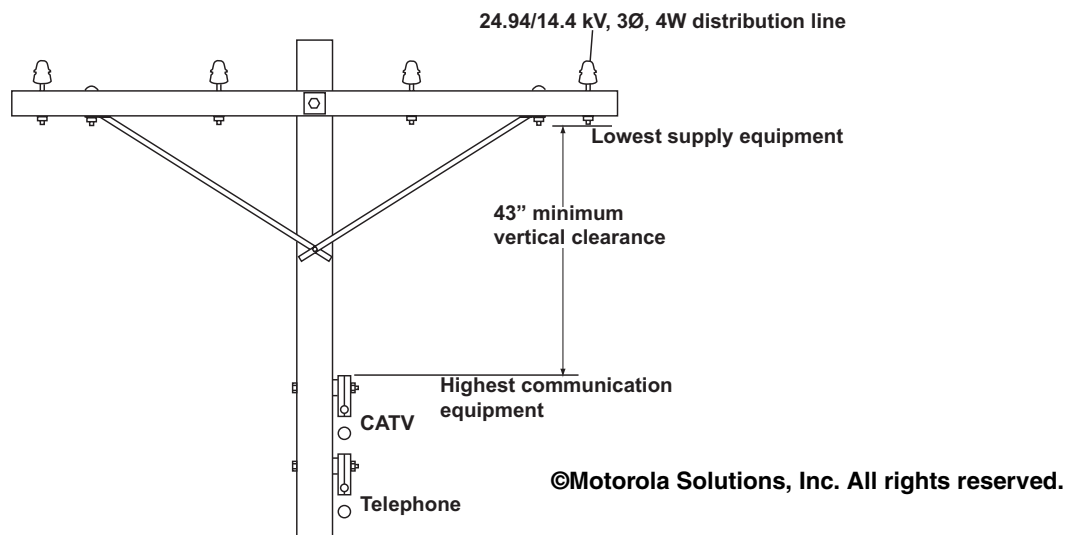

Figure 9-59 Supply to Communication Equipment Clearance - 14.4 kV Supply

- Not less than 762 mm (30 in) of vertical clearance between the effectively grounded neutral hardware and the communications equipment (Figure 9-60). See NESC[®] Rule 238B.

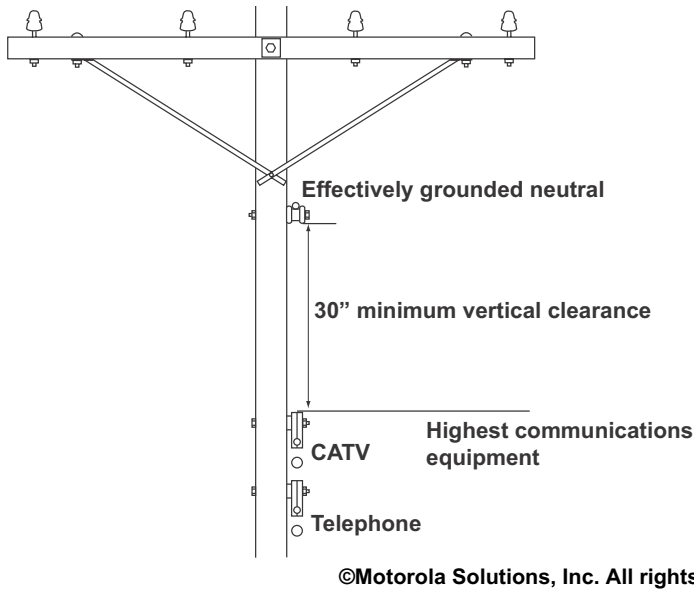

Figure 9-60 Vertical Clearance Between Grounded Neutral and Communication Equipment

- Not less than 762 mm (30 in.) of vertical clearance between non-current-carrying parts of effectively grounded supply equipment (for example, the transformer case) and the communications equipment (Figure 9-61). See NESC[®] Rule 238B.

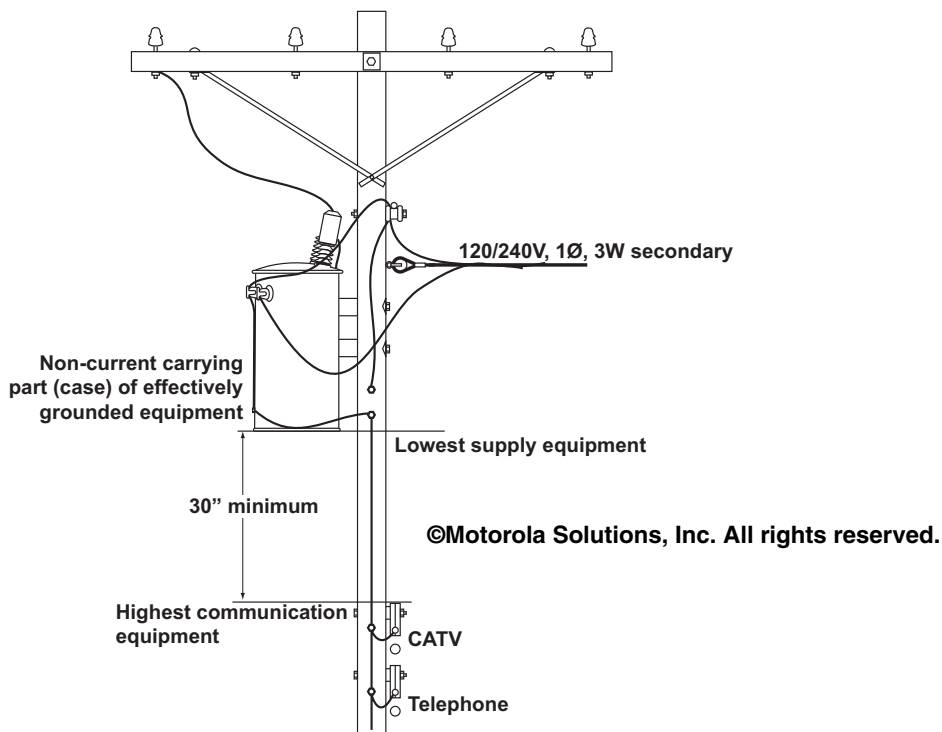

Figure 9-61 Vertical Clearance Between Communication Equipment And Non-Current-Carrying Parts (Secondary Above Bottom)



NOTE

The non-current carrying parts of supply equipment must be consistently grounded throughout a well-defined area and the neutral associated with the supply equipment must be bonded to the communications equipment.

- Not less than 102 cm (40 in.) of vertical clearance between a 120/240 V, 1Ø, 3W secondary triplex (see NESC[®] Rule 230C3) and the communications equipment (Figure 9-62). See NESC[®] Rule 238B.
- Not less than 101 cm (4 in.) of vertical clearance between a luminaire bracket and the communications equipment (Figure 9-63). See NESC[®] Rules 238C and 238D.
- Not less than 305 mm (12 in.) of vertical clearance between a luminaire supply conductor drip loop and the communications equipment (Figure 9-63).
- All clearances **shall** meet the requirements of the utility and/or the AHJ. The requirements of the AHJ **shall** take precedence over the requirements listed in this section.

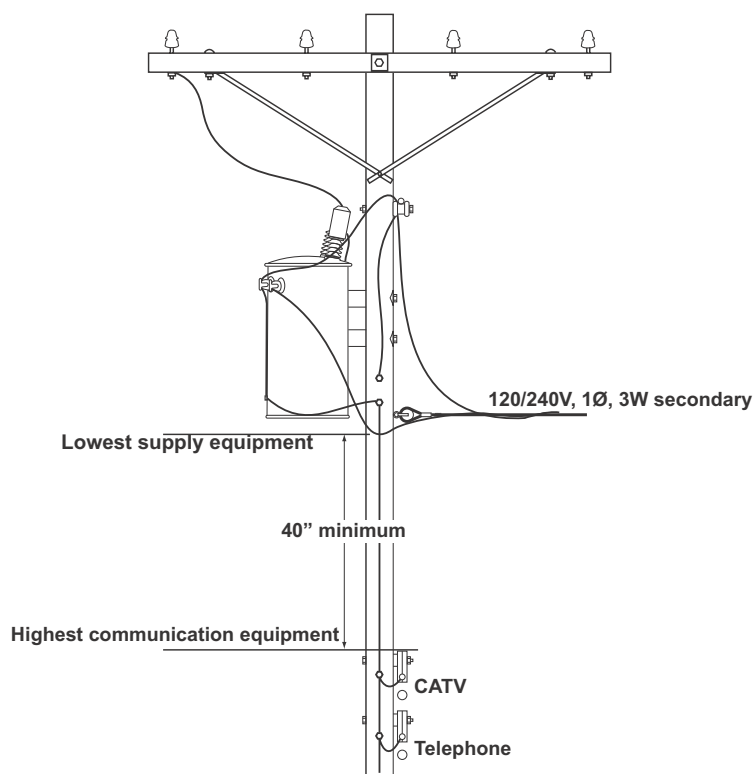

©Motorola Solutions, Inc. All rights reserved.

Figure 9-62 Vertical Clearance Between Communication Equipment and Non-Current-Carrying Parts (Secondary Below Bottom of Grounded Case)

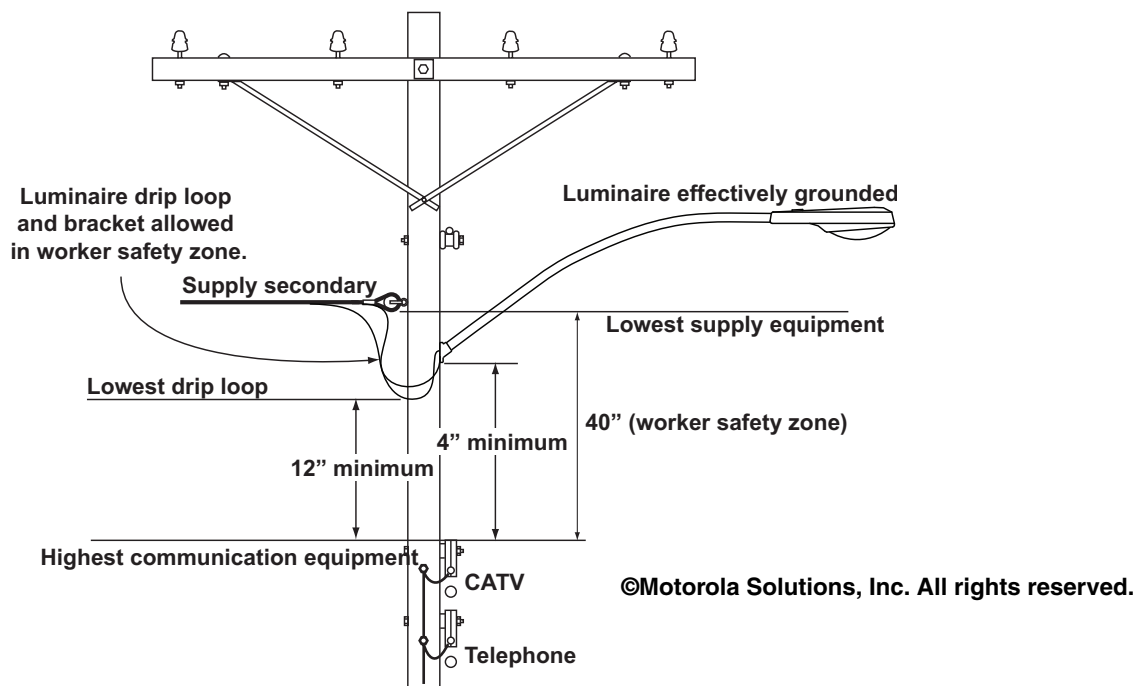

Figure 9-63 Luminaire Bracket and Drip Loop Clearances

9.15 Electrostatic Discharge Considerations

Electronic equipment is vulnerable to damage caused by Electrostatic Discharge (ESD). While newer equipment is becoming more susceptible to ESD damage, older equipment is also easily damaged by ESD as well. See Appendix C, “Protecting Against Electrostatic Discharge in Equipment Rooms and Dispatch Centers”, for more information.

The following electrostatic discharge practices **shall** be observed whenever installing or servicing electronic equipment:

- ESD wrist straps **shall** be available at the site.
- An ESD wrist strap **shall** be worn when handling ESD sensitive modules. ESD wrist straps **shall** be snug fitting, making firm contact with the user's skin.
- Protective wrapping that is ESD treated **shall** remain on the equipment until the equipment is placed near its final location.
- ESD rated packaging **shall** be available at the site for storage and transportation of static sensitive components.
- All precautions specifically stated for the equipment being worked on **shall** be adhered to in accordance with the respective documentation for the equipment.
- See Appendix C, “Protecting Against Electrostatic Discharge in Equipment Rooms and Dispatch Centers”; and Telcordia GR 1275 Issue 3, Section 9.



CAUTION

Do not handle ESD sensitive equipment without taking appropriate precautions.

Electromagnetic Energy (EME) Information

This appendix includes the following topics:

- “Environmental Evaluation,” on page A-2
- “Engineering Considerations,” on page A-10
- “Work Practices,” on page A-14
- “Signage,” on page A-17
- “Personal Protective Equipment (PPE),” on page A-20
- “EME Action Thresholds Summary,” on page A-21



NOTE

This appendix specifically references the United States FCC, but there are similar authorities having jurisdiction located around the world. Ensure that requirements of the relevant authorities having jurisdiction are implemented in your region.

A.1 Introduction

This appendix provides information to assist in understanding the concepts required to comply with FCC guidelines for human exposure to Electromagnetic Energy (EME) at antenna sites. This information is **not** intended to replace a structured training program, but is intended to provide basic information and methodology in structuring an Electromagnetic Energy compliance program. The methods presented in this appendix represent one approach for meeting FCC requirement; other methods may also meet FCC guidelines.

In August 1996, the Federal Communication Commission (FCC) adopted new guidelines for evaluating the environmental effects of Radio Frequency (RF) energy from transmitters on wireless communication sites. While there is no scientific evidence that RF emissions from these sites operating within established safety guidelines pose a health risk, fields close to antennas on transmitter sites must be understood and care must be taken to assure safe operation during maintenance. The guidelines adopted by the FCC provide considerable margins of protection from any known health risk.

This text discusses some of the issues involved in analyzing and understanding the Electromagnetic Energy (EME) environment that may exist on a complex communications site. A complex site is not only a site with hundreds of transmitters, antennas and some broadcast, but any site with more than one RF transmitter. Considerable investigation has been done to understand the levels of exposure associated with such facilities, but little has been written on the implementation of procedures to ensure operating conditions in compliance with the FCC guidelines.

Modern communication sites typically contain many transmitters serving various functions or services, such as cellular, PCS, ESMR, paging, basic two-way radio, broadcast, and so on. With each of these services requiring separate transmitters, in the past each service would typically develop its own sites and exist alone. However, with the dramatic growth of these services has come a growing incentive and need for transmitter collocation (the grouping of transmitters for different communications services at a single site). This collocation naturally results in correspondingly greater densities of EME fields about the site.

The drive for collocation comes from the need for more sites to satisfy public demand for more communications services, as well as public reaction to the proliferation and location of those sites. This will create communications sites more dense than has ever been dealt with before. In order to accommodate this natural growth in antenna density, more locations that consolidate communication transmitters are likely.

While collocation is a logical response to the marketplace factors outlined in this section, it presents challenges to the companies providing these services. As more transmitters are added to a site, the density of RF generators and EME increases. This is not unlike the situation found on a hilltop surrounding a large metropolitan area. The best hilltops have a high density of broadcast and communications sites. Because these are usually located on a common ridge or peak, the RF density may at times approach recognized exposure limits.

This appendix discusses some of the issues that must be considered in the management of a complex communications site. These considerations are important in order to ensure the operation of sites within recognized exposure limits. The RF density increases with the increase in the number of transmitters. However, operating conditions in compliance with the FCC guidelines can help be assured by the use of basic principles discussed here.

A.2 Environmental Evaluation

The possible health effects associated with exposure to EME have been studied for more than half a century. Scientists first identified the exposure threshold above which RF energy may cause adverse biological effects. The only established adverse effect of RF energy relates to the heating of tissue. Standard-setting bodies then set recommended exposure limits that are substantially below this threshold by at least a factor of 10 or more. With this substantial built-in margin of protection, these standards constitute reliable science-based guidelines for safe human exposure. Internationally, EME exposure standards exist in many countries. In the United States, one accepted standard comes from the American National Standards Institute C95 committee formed in the late 1950s. This committee has undergone many changes and implemented several standards. In 1988 the Institute of Electrical and Electronics Engineers (IEEE) became the sole sponsor of the C95 Committee, and the committee became the IEEE Standards Coordinating Committee (SCC), SCC28. In 1991 IEEE adopted their current standards as IEEE C95-1991. These standards were subsequently recognized by ANSI (American National Standards Institute) in 1992 as the ANSI/IEEE C95-1992 standard for safety levels of radio frequency exposure. The exposure limits in the ANSI standard are similar in many respects to those set by the National Council on Radiation Protection and Measurements (NCRP), an independent organization chartered by the U.S. Congress.

The Federal Communication Commission recently adopted guidelines which generally followed the recommendations of expert health and safety agencies such as the EPA, FDA, OSHA, NIOSH, and others, to adopt field and power density limits as recommended by the NCRP Report No. 86 and the SAR limits from the ANSI/IEEE C95.1-1992. See FCC Report and Order (FCC 96-326) and Second Memorandum and Order (FCC 97-303) for additional information. These can be found on the FCC Office of Engineering and Technology website: www.fcc.gov/oet/rfsafety.



NOTE

As of the publication of this manual, IEEE C95.1 was updated in 2005 (IEEE C95.1-2005) and amended in 2010 (IEEE C95.1a-2010).

A.2.1 Exposure Standards and Limits

With the publication of the SCC28 standard as ANSI/IEEE C95.1-1992, a number of new elements were added to prior ANSI standards. These changes included modification of the exposure limits and the classification of exposure environments as Occupational/Controlled and General Population/Uncontrolled. Exposure limits in the new guidelines adopted by the FCC are specified in terms of Maximum Permissible Exposure (MPE) as a function of frequency; MPEs are given in units of electric and magnetic field strength and power densities. For exposure to multiple frequencies, the fraction (or percentage) of the MPE produced by each frequency is determined and these fractions (or percentages) must not exceed unity (or 100 percent).

If the RF fields at a specific location are composed of four frequencies and their fields represent the percentages of the applicable MPE for Occupational/Controlled environments as identified by the FCC are shown in the following example, the resulting exposure can be expressed as 85% of the allowable Occupational/Controlled MPE and continuous exposure would be in compliance with the FCC limits. An example is shown in Table A-1.

Table A-1 EXAMPLE OF MAXIMUM PERMISSIBLE EXPOSURE

Frequency (MHz)	Measured Power Density	MPE
155.025	0.25 mW/cm ²	25%
465.0125	0.54 mW/cm ²	35%
955.0125	0.48 mW/cm ²	15%

Table A-1 EXAMPLE OF MAXIMUM PERMISSIBLE EXPOSURE (CONTINUED)

Frequency (MHz)	Measured Power Density	MPE
851.0125	0.28 mW/cm ²	10%
Total Exposure:		85%

Different limits apply to different circumstances (see Figure A-1), based on whether a person at or near a specific site knows or is informed and has control of potential RF exposure. Occupational/Controlled Environment limits apply to individuals who should know that there is a potential for exposure as a requirement of employment, or as the incidental result of transient passage through areas that may exceed exposure levels beyond the General Population/Uncontrolled environment MPEs. For example, a maintenance technician who performs work on transmitters should be aware (due to training and the nature of his work) that transmitters produce RF energy. Because of the knowledge and understanding that exposure is possible, this individual would be evaluated against the Occupational/Controlled environment limits. General Population/Uncontrolled Environment limits apply to individuals assumed to have no knowledge of, or control over, their possible exposure to RF energy. If the technician in the example brought his family to the same area, the situation would change. Because the family members would not be assumed to have knowledge or understanding of the RF environment, their exposures would be judged against the limits for General Population/Uncontrolled environments. The technician, however, would be evaluated against the Occupational/Controlled environment limits. Simple understanding or precautions can assure that RF levels at or near an antenna site do not exceed maximum permitted exposure levels. The MPE exposure levels for General Population/Uncontrolled environments are five times lower than the MPE exposure levels for Occupational/Controlled environments. The technician, in the example, could be exposed to a power density of 3 mW/cm² from a 900 MHz transmitter while the family members could only be exposed to 600 μ W/cm².

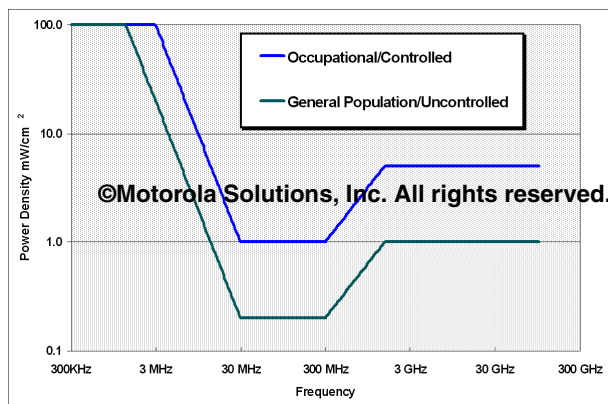
**Figure A-1** FCC Adopted Maximum Permissible Exposure Limits

A.2.2 Compliance Analysis

A.2.2.1 Spatial-peak

The maximum RF energy across the area of the human body (about 1.8 m (6 ft) high) that an individual can be exposed to, is considered the Whole Body Peak (WBP). This level should be considered as the highest level that is found in the area of interest. If, during the evaluation of an area for exposure, there are no WBP exposures above the MPE being considered, the area is considered below the limits and requires no additional evaluation.

A.2.2.2 Spatial-averaging

If, during the evaluation of an area for potential exposure, it is determined that there are areas where peak levels (WBP) will exceed the MPE, then spatial-averaging is required. Spatial-averaging considers the whole area of the human body in the evaluation of exposure. If there is an area that has RF fields above the applicable MPE, additional vertical measurements should be taken to understand the levels between ground level and 1.8 m (6 ft) high. (The ANSI/IEEE C95.1 - 1992 standard uses a height of 2.0 meters.) The average of these vertical measurements is the Spatial-averaged exposure, which is used to evaluate compliance with the MPE.

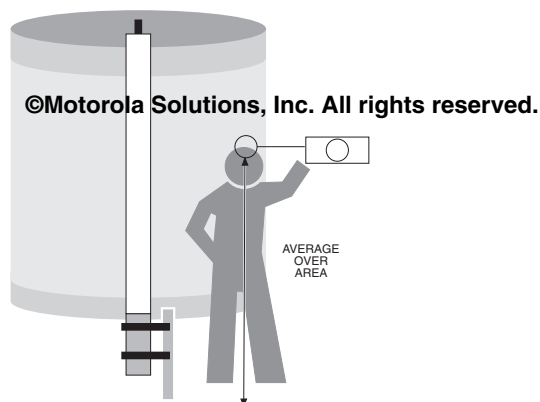

Figure A-2 Spatial Averaging

A.2.2.3 Time Averaging

MPEs in the guidelines are in terms of a time-averaged exposure, typically either 6-minute for Occupational/Controlled MPE or 30-minutes for General Population/Uncontrolled MPE. The averaging times are used to regulate the energy absorption rate in an individual exposed to RF fields so that the total energy delivered over the averaging time does not exceed FCC guidelines. This permits short duration exposure to much higher level fields as long as the average value over the prescribed time remains within the MPE.

The FCC MPE is time and spatially averaged. It is therefore permissible to exceed the numeric values of the MPE for brief periods of time and in some locations of space as long as the average exposure does not exceed the limits over the time and space indicated.

While time averaging is considered an acceptable mechanism for managing high exposure levels, it requires considerable attention and consideration. There is potential for error and thus, the use of time averaging alone generally should be avoided. If situations are encountered where levels exceed the exposure permitted with spatial-averaging, then other means **shall** be utilized to reduce exposure. There are situations however, where time averaging may prove to be an acceptable method available to control exposure. One of these situations is tower climbing. While on a tower, a climber may move through fields that are in excess of the limits for continuous exposure. If a steady rate of ascent is maintained the time-weighted averaged exposure can be maintained below the limit allowed in the guidelines.

A.2.3 Exposure Evaluation

Evaluating possible RF exposure levels can be done using both theoretical models and physical testing. Modeling a site allows the tester to be aware of situations and anticipate locations where close physical examination is required.

The maximum exposure allowed by the FCC limits is 100% of the MPE, averaged over both time and body height. To provide a margin of tolerance to ensure compliance, in many cases an additional factor of 3 dB or 50% should be adopted as an action threshold. Any levels above 50% of the applicable MPE **shall** have action procedures to maintain compliance.

A.2.3.1 RF Modeling

Modeling is the theoretical calculation of RF fields based on the situation. With a minimum amount of data, the field strength can be estimated before actual testing begins. To fully apply modeling, the characteristics of the antenna radiating in free space must first be understood. The field radiates from an antenna like a ripple in the water after a pebble is thrown. The closer to the source, the more curved the wave front will be; further from the source the circle becomes very large and the wave front has less curvature. Far from the source, the field appears planar. The field will still be curved but within the limits of observation it appears to occupy a flat plane in space, for example, plane-wave radiation.

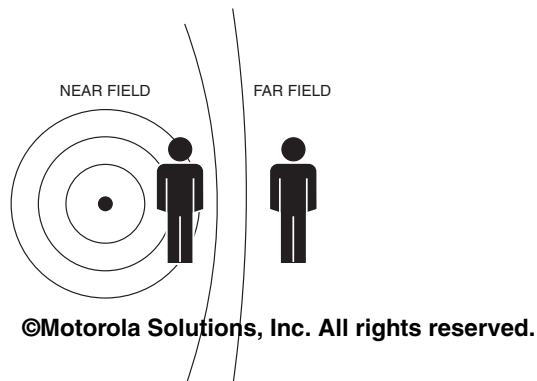

Figure A-3 RF Modeling

Close to the antenna is a region referred to as the **near field**. Within this region the spatial characteristics of the RF fields are very complex. The average power density within the near field varies inversely with the distance from the antenna. In other words, as distance from the antenna increases, the power density is reduced inversely with distance, D . This is the so-called $1/D$ region.

Further from the antenna is the **far field**. In the far field, the beam has developed and propagates in a behaved manner. In the far field as distance from the antenna increases, the power density decreases inversely with the square of distance. This is the so-called $1/D^2$ region. This signal intensity characteristic is commonly used to predict coverage. Far field calculation of signal strength is the normal approach for estimating signal strength a mobile receiver will receive.

From the standpoint of anticipating the power density to which a person will be exposed from an antenna, both the near and far fields must be understood. If RF levels are predicted very near an antenna based on the square of the distance (as is indicated in the far field formula), the calculated levels increase faster than what really occurs close to the antenna. There is a point called the crossover point where the two fields meet. Before this point the power density drops off linearly and after this point the signal reduces as an inverse square relationship. If both formulas are considered, there is a point of intersection. This crossover point is defined as the boundary of the near field and far field.

The power density decreases much faster in the far field than the near field. There is a distance from the antenna where the field strength of near field and far field are equal or intersect. The point of intersection (crossover point) is the boundary for the two zones.

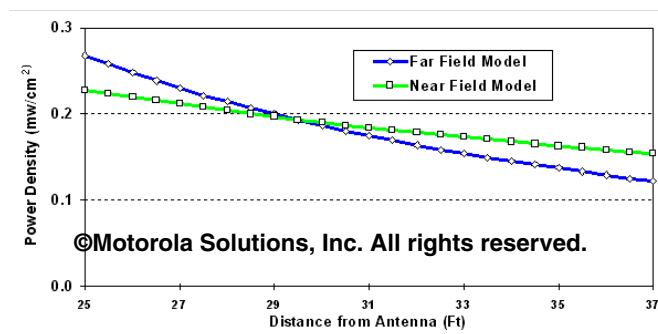

Figure A-4 Example of Near Field/Far Field Crossover

Figure A-4 illustrates the crossover for a 6 dBd gain omni antenna that is 2.74 m (9 ft) in length. As the aperture length and gain change, the crossover point will also change greatly. For the example in this section, the crossover point is approximately 9.14 m (30 ft). For an antenna with 10 dBd of gain and an aperture length of 3.96 m (13 ft), the crossover point will be over 30.5 m (100 ft). A 3 dBd gain antenna with an aperture length of 457 mm (1.5 ft) will have a crossover point of only 914 mm (3 ft).

A.2.3.1.1 Cylindrical Model

For vertical antennas, with omnidirectional horizontal patterns, the power density in the near field can be estimated using the circular radiation pattern and the height of the antenna. The area of a cylinder placed over this antenna is assumed to be uniformly exposed to the power radiated by the antenna; no RF energy emanates from the top or bottom. This power density is approximately the same as the average power density an individual of a specific height would be exposed to when standing next to the antenna. This formula is referred to as the Cylindrical Model because it utilizes a cylinder for the modeling (see Figure A-5).

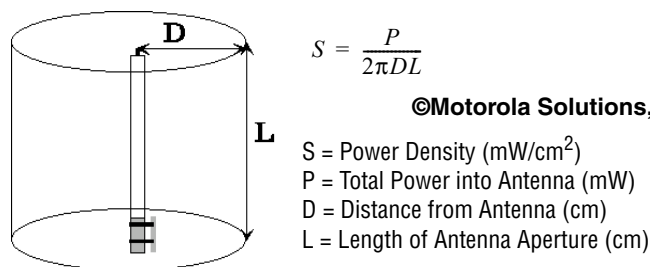

Figure A-5 Cylindrical Model

Shorter antennas result in higher fields and exposure for a constant power. The greater the power, the higher the EME field. The shorter the aperture, the higher the EME field. The closer to the antenna, the higher the EME field.

A.2.3.1.2 Spherical Model

In the far field, the radiation pattern becomes developed and does not change with distance from the antenna. The maximum radiating power density becomes related to the gain of the antenna. In the far field, the power density decreases as the square of the distance. With an isotropic point source (omnidirectional in all directions) the power density can be envisioned as the source power distributed over a sphere having a radius equal to the distance from the antenna. When the antenna has gain, the maximum power density in the far field can be calculated using the following formula:

$$S = \frac{PG}{4\pi D^2}$$

S = Power Density (mW/cm²)
P = Total Power into Antenna (mW)
G = Gain Ratio of Antenna based on an Isotropic radiator
D = Distance from Antenna (cm)

A.2.3.2 RoofView™ EME Modeling Software

RoofView is a modeling software package that allows a theoretical study of site situations. The software creates a mosaic map of the area showing the EME levels (see Figure A-6). The calculations can use different methods, different standards, antenna heights and uptime for evaluation. There are two versions:

- **RoofView** is the building version showing EME situations on a single plane.
- **TowerCalc™** is used to model towers. This will allow the EME situation on any level of the tower to be understood.



NOTE

Trademark RoofView™ and TowerCalc™ are licensed to Richard Tell Associates, Inc., Las Vegas NV. Additional information can be found on www.radhaz.com.

The software runs on Excel for Windows. The information needed to create a model and generate a zoning map is:

- Transmitter Power into Antenna
- Frequency
- Antenna mount designation
- Antenna location on roof
- Antenna Characteristics
 - Gain
 - Aperture Length
 - Mounting Height



Figure A-6 EME Zone Map of a Complex Rooftop Antenna Site

RoofView calculates and plots a pictorial representation of EME levels. Antenna fields can be expressed directly as a percentage of user selectable MPEs. This is analogous to running a range prediction coverage map. During RF system design an understanding of coverage is important. During site design EME evaluation is important.

A.2.4 EME Zoning

After the exposure levels are determined an evaluation and classification **should** be performed. The classifying of the exposure allows site managers to understand the complete situation and develop procedures to ensure exposure to employees and contractors is maintained below the acceptable limits.

Classifying exposure focuses on comparing the levels found against the Occupational/Controlled MPE. As the term indicates, MPE is the maximum permissible exposure an individual should encounter. To further classify areas, a standard color coding can be adopted to clearly show the EME levels.

On a site where RF transmitters and their associated antennas are located, it is usually necessary to restrict the access of the general population. This area frequently is bounded by walls, fences, and other natural or manmade structures. Within this area three zones (Green, Yellow and Red) will be used to determine the requirements for compliance to the FCC guidelines.

A.2.4.1 Green Zone

The green zone is any area where the time (as appropriate) and spatial-average is below 20% of the Occupational/Controlled MPE. The areas so classified afford the highest level of protection for individuals working in RF fields. There is no time limit and no special EME safety practices are required for these areas. Individuals working in this zone may need only basic EME awareness. This can be conveyed with signs, plaques or awareness videos to provide the information necessary to create an awareness and understanding of the environment.

Green Zones denote the lowest EME levels at the site. This area is usually associated with equipment rooms, ground areas around towers and other areas significantly removed from transmitting antennas. The green zone is unique because the exposure levels are below the General Population/Uncontrolled environment MPEs. Care and proper consideration in site design **shall** be done to ensure these levels are maintained. On high-density sites annual (or more frequently if required) evaluations **should** be done to ensure compliance.

Equipment rooms and areas around the base of towers **should** always be required to have fields low enough to allow a green classification. The verification and certification of this low level may be required on some sites. If locations are discovered in excess of these levels, changes and modifications must be incorporated to maintain green-zone status. Some methods to maintain green-zone levels are:

- Proper maintenance of RF transmitters. This includes ensuring all shields are maintained properly and installed correctly.
- Not allowing transmit antennas inside equipment rooms or near the ground level of sites.
- Ensuring all microwave dishes are directed away from facilities.
- Proper use and installation of transmission lines and connectors. When waveguide carrying high power is used, verification of fitting integrity must be performed to ensure there is no RF leakage.

A.2.4.2 Yellow Zone

The yellow zone is any area where the spatial-average is between 20% to 100% of Occupational/Controlled MPE. While the fields in this area are within acceptable limits, caution must be exercised because nearby locations may exceed the limits. Therefore, individuals in these areas should have heightened awareness and understanding of their potential for exposure. Normally, there will never be a yellow zone without another zone of higher level in the vicinity. Personnel without EME awareness training **shall not** frequent this area regularly. Only personnel with the proper knowledge and understanding of EME compliance procedures **shall** be allowed to work in areas designated as yellow zones. Appropriate Caution signs **shall** be posted to inform personnel of the EME situation.

Yellow zones **should** be posted to ensure all personnel entering understand the area is controlled. The EME levels in a yellow zone are below the MPE for Occupational/Controlled environments, but not for General Population/Uncontrolled environments. **Only** individuals who have the knowledge and requirement **should** be given access.

A.2.4.3 Red Zone

The red zone is any area where the spatial-averaged levels fall above 100% of Occupational/Controlled MPE. When locations are found to require red zoning, special procedures, engineering or restricted access must be implemented to ensure compliance. Some procedures that can be implemented are:

- Restrict Access
- Lock-out/Tag-out of transmitters during maintenance of antenna system
- Control of antenna types used for site design
- Re-engineer site to reduce EME fields
- Measure and consider uptime. “Uptime” is the percentage that a transmitter will likely be keyed (see “Uptime” on page A-12 for detailed information).

A.2.5 Characterization Zoning

The level of RF energy to which one is exposed is called Exposure. The quantity of exposure depends on the duration and strength of the field. In most cases, the characteristics of a site will determine the EME exposure potential. Understanding these characteristics will aid in predicting and preventing levels that exceed the FCC Guidelines and allow the site manager to establish the proper procedures for personnel who frequent these areas.

A.2.5.1 Buildings

Building sites are normally in dense, metropolitan cities. The buildings used are normally the highest structures in the city and offer the unique opportunity of height without the need for a long feedline. The facility which houses the radio transmitters is normally close to the antennas which reduces the loss between the antenna and transmitter, allowing maximum power to the antenna. While this maximum power provides extended range, it increases the EME levels around the antennas. The main determinants of EME are frequency, power into the antenna and aperture height. The greater the power, the higher the EME field. The shorter the aperture, the higher the EME field for a given power.

On buildings, the antennas are generally mounted on the roof. This mounting arrangement is normally laid out on a single plane and distributed in a grid arrangement, within the confines of the roof. The mounting is normally on a pipe structure and the separation can be as close as 914 mm (3 ft) in some cases. This arrangement provides for maximum mounting density, but it may leave little space for the workers performing maintenance. Any worker attempting to change an antenna, repair a cable or perform general maintenance may be exposed to high levels of RF energy from other antennas surrounding the work area. Proper engineering design should be used to prevent this situation. By reducing all the fields on a building the potential for high exposure is eliminated and provides the best compliance resolution.

A.2.5.2 Towers

Towers are antenna supporting structures that can be found in various locations ranging from central metropolitan, to isolated rural locations. Normally, the towers are designed to elevate the antennas in accordance with the intended coverage area. This can vary from 30.5 m (100 ft) for cellular to 610 m (2000 ft) for two-way communications. Regardless of the height of the supporting structure, the characteristics are the same. The application of the antennas that are being supported determine these characteristics. Cellular towers usually have directional antennas mounted on a single face to define a sector. There may be several faces and several directional antennas per face. A two-way tower can have several antennas mounted in a star configuration to maximize the density of antennas at a position on the tower. Additionally there can be several star mounts on a single tower.

With respect to EME, the cellular configuration presents less exposure to people working on the tower than the two-way tower configuration because the RF radiation of the directional antenna is aimed away from the tower. There is a significant power difference between the front and the back side of the antenna. This difference is called front-to-back ratio. While the front-to-back ratio can be as great as 25 dB in the far field it is less well developed in the near field. There is still reduction of the exposure of the worker in the near field behind, as compared to the front of the antenna, but the amount may be considerably less than the advertised far field front-to-back ratio.

The situation on two-way towers is significantly different. As workers climb up the tower they may encounter several antenna mounts at various locations on the tower. These mounting areas can contain various types of transmitters ranging from paging transmitters with hundreds of watts of power to large antennas for transmitters in the 35 MHz frequency range. While the antennas and the resulting mounting arrangement can be considerably different, in some conditions the EME levels may approach or exceed the FCC guidelines. In the case of the paging transmitter, the antenna will normally be an omni configuration with an aperture length of 1.2 m to 4.6 m (4 to 15 ft). The antenna will be mounted from 1.2 m to 1.8 m (4 to 6 ft) from the tower. Fields directly adjacent to the aperture will present the highest levels. Because of this, workers **shall** use caution while working or stopping directly in front of these antennas unless the transmitters are deactivated. If the antenna is grouped with other antennas at the same level more than one transmitter may need to be deactivated. Another important characteristic of paging is the duty cycle of the transmitter. The importance of duty cycle will be discussed in detail later.

Star cluster mounts (see Figure A-7) or candelabras present a significant issue in the management of EME on towers. If there are five to eight antennas mounted in a circle and these antennas are located 1.5 m (5 ft) from the tower, there is the potential for an EME level in the center that exceeds the limits. Because the center is the tower, workers must ensure they understand the fields while entering this area.

Figure A-7 shows the computed effects of several transmitters using the EME modeling program described. Each square pixel represents 929 cm² (1 sq. ft) of resolution. This simulates the effects of five PD-10017 antennas with 100 W into the antenna at 900 MHz. A worker entering this area may be exposed to EME levels above the applicable MPE and **shall** take appropriate steps, such as moving quickly through the area, to assure compliance with recognized exposure guidelines. What makes this situation difficult to manage is the fact that the field and the resultant high EME levels from all the antenna fields overlap and add. While this situation can exist, the fields are reduced by the cable loss associated with the height of the candelabra and are therefore more manageable. Most candelabras are mounted on top of a tower.

Because of the cable loss associated with towers, the power into the antenna is significantly lower than buildings and hilltop sites. This loss between the transmitter and antenna reduces the power and ultimately the fields produced. Higher frequencies have higher line loss, which significantly reduces the power at the antenna. This fact is very important and proves to significantly reduce the fields produced on tall towers.

Candelabra and star mounts present unique compliance and maintenance situations due to the additive nature of EME exposure at these locations. Insertion losses of transmission lines reduce the power into the antennas and reduce the likelihood of strong fields on clusters located at high levels on tall towers. For equal transmitter power, the higher the frequency, the higher the insertion loss; thus EME levels are lower on tall towers.

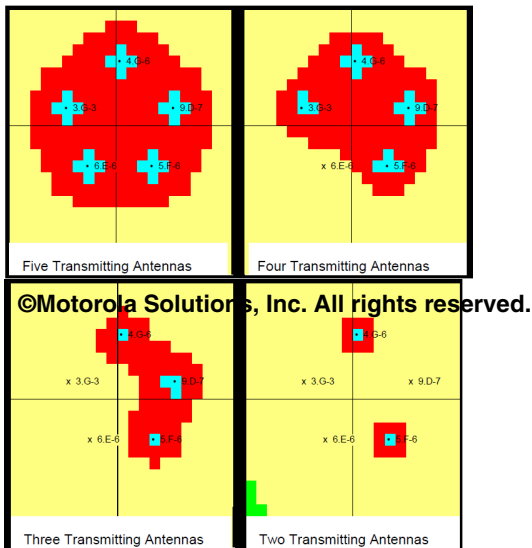

Figure A-7 EME Zone Map of a Tower Mounted Star Cluster Mount or Candelabra (Resolution 1 sq. ft)

A.3 Engineering Considerations

A.3.1 Antenna Elevation

One common technique for reducing the RF levels expected on large roof tops is to elevate the antennas above the roof. Elevating the antennas raises the EME fields above the roof and reduces the power density to which an individual at roof level will be exposed. The results of elevating antennas are illustrated in Figure A-8. These data are based on the EME fields produced by an 850 MHz SMR antenna. Ten 150 Watt transmitters through a combiner drive the antenna. The resultant 550 Watts of power is fed into a 3.96 m (13 ft) omni antenna. This type of antenna configuration is not unusual on rooftops.

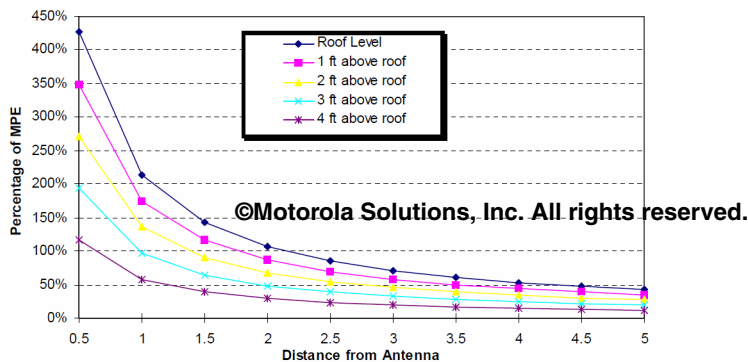

Figure A-8 Exposure vs. Antenna Height Above Roof

The resultant exposure possible can be above the MPE when the antenna is mounted at the roof level. From the chart, fields in excess of 200% of the Occupational/Controlled MPE are encountered within 305 mm (1 ft) of the antenna. While this seems extremely close, a technician walking down the center of an antenna grid with 1.2 m (4 ft) centers will be 610 mm (2 ft) from any antenna at any time. At a distance of 610 mm (2 ft) from this antenna mounted at roof level, it is possible for the exposure to be over 100% of the same MPE. If this situation is compounded with several antennas having the same power density, the levels in this walking area could be above the MPE. For this reason every effort should be given to reducing the fields at the roof level. The most effective technique for reducing the fields on a building, while maintaining constant radiated power, is raising the antenna. Raising the antenna 1.2 m (4 ft) above the roof reduces the EME field strength at the roof level to about 50% of the MPE at 305 mm (1 ft) from where the antenna was. If the antenna is raised 1.8 m (6 ft) above the roof the fields are reduced more than 90%.

The most effective technique for reducing EME levels is elevating antennas on buildings and extending antennas away from the tower.

A.3.2 Extending Antennas Away From Towers

Tower contractors climbing the tower must pass through fields created by active antennas on the tower. Antennas mounted on short sidearms or mounted directly to the tower produce high levels of exposure to tower climbers. It is a good engineering practice to mount omnidirectional antennas a minimum of 1.52 m (5 ft) from the tower.

A.3.3 Collocated Broadcast Transmitters

Areas with broadcast transmitters can have fields created by grating lobes from the antenna or fields developed directly by the main radiating beam. On broadcast-only sites these are the only field that must be considered in EME analysis. On collocated sites, the EME fields are a combination of the fields generated by two-way transmitters and broadcast stations. If the exposure from each contributor is considered independently and then added, the total MPE situation can be evaluated. The fields from the broadcast transmitter act like a blanket covering the area. If the fields from a preexisting broadcast station create a level of 15% Occupational/Controlled MPE there is only 85% of the MPE budget remaining. This requires the levels from the two-way transmitters to be lower than what otherwise would be required to maintain compliance. In some conditions extra cooperation between the broadcasters and two-way licensees may be necessary to ensure site compliance. In the areas that receive grating lobes from the broadcast transmitters, careful measurements must be done before compliance can be analyzed.

Consideration must be given to anyone working on antenna systems. If a person must climb into the fields of the broadcast antenna, coordination ahead of time must be done to reduce the transmitter power. Special consideration and care **shall** be utilized when a person is required to climb through a field known to exceed 100% Occupational/Controlled MPE. On some sites the broadcast towers are mounted adjacent to the two-way tower. In this situation the fields from the broadcast transmitter will be very intense on the two-way tower. Maintenance activities must be coordinated when the broadcast station is collocated. The FCC requires broadcasters to cooperate during maintenance situations; however, they may elect special times to conduct maintenance.

A.3.4 Location of Directional Antennas

Directional antennas in the horizontal plane present a focused pattern for maximum coverage into a specific area. Even in the near field the levels in the beam of the antenna can be significantly higher than behind or on either side. Consideration must be given to the area and location the antenna is directed. Directional high-powered transmitting antennas should be located where the energy in excess of the Occupation/Control MPE is directed away from any area frequented by workers. Additionally directional antennas **shall not** be installed where they can produce fields higher than the General Population/Uncontrolled MPE in uncontrolled areas.

A.3.5 Antenna Selection

Antenna selection is important because it is directly linked to EME levels. The requirement for more antennas within a given horizontal space has created new designs of antennas. Within one radome several antennas can now be stacked on top of each other. The standard configurations are double (two), triple (three) and Quad (four) co-linear arrays. Aperture length directly affects the power density created. In the near field, a 4.6 m (15 ft) antenna driven with 500 Watts will have one-third the power density of an antenna 1.52 m (5 ft) long. Remember that near the antenna, the power density is related to the surface area of a cylinder placed over the antenna. A cylinder having one-third the height will have one-third the surface area and, hence will result in three times the power density. This is complicated even more when the 1.52 m (5 ft) antenna is placed with other antennas in a common radome. This allows the power density, created by each antenna, to combine and increase the potential

exposure of an individual. The technique of using triple and quad antennas is becoming increasingly popular as the space on hilltops and towers becomes scarcer. Paging transmitters, sectored antenna systems and digital networks represent only a few of the services requiring individual antennas. There is a finite antenna density that can be accomplished within a given area. Creative methods of combining or increasing the antenna structures must be developed. Consideration should be given to connecting lower power transmitters to the bottom portion of triple and quad radome antennas.

A.3.6 Mounting Density of Antennas

While the RF fields from one antenna may be below the MPE allowed, the combination of fields from several antennas can produce levels exceeding the Occupation/Control MPE. Figure A-9 and Figure A-10 show the fields produced by one antenna and the fields produced by five antennas mounted at roof level with all transmitters keyed simultaneously.

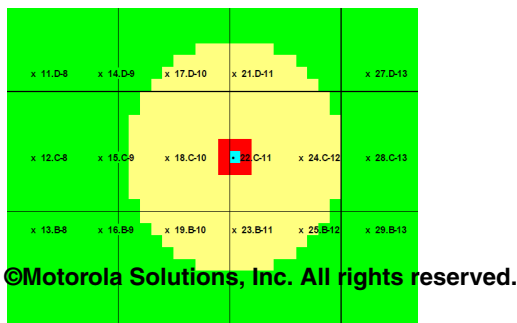

Figure A-9 Composite RF Fields with One Antenna Transmitting

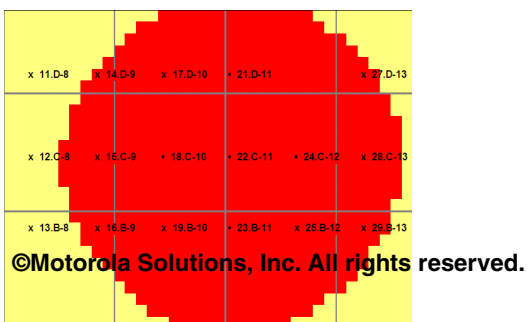

Figure A-10 Composite RF Fields with Five Antennas Transmitting

The combined fields produce levels exceeding the MPE allowed in all areas surrounding the antennas. In these situations, some means of controlling exposure must be used. These techniques may include RF protective clothing, re-engineering the antenna system or power shutdown or reduction when working in the area. While power shutdown or reduction may appear to be an effective technique, either may be impractical for wireless communications services. It is normally reserved for broadcast transmitters. One preferred method of addressing this is to elevate the antennas above the roof area.

A.3.7 Uptime

Complex antenna sites have a “personality” that makes them unique. The personality of the site is not only determined by the RF power, frequency and manufacturer of the equipment, but by the operational characteristics. The RF level and frequency can be determined by understanding the equipment specifications, but operational characteristics can only be quantified by monitoring the usage. Because of the high number of pagers, paging transmitters will have a very high transmitter duty cycle. Trunking (SMR) transmitter activity will depend on customer loading density. This can range from transmitters rarely transmitting, to transmitters rarely not transmitting. Private customer equipment will have a very diverse usage characteristic that can not be predicted. The important point in understanding the characteristics of different services is that they can seldom be predicted.

Additionally, characteristics for transmitters will change due to cultural elements. Transmitters located in Las Vegas will have considerably different uptime characteristics than transmitters located in San Antonio, Texas or New York City. Tests have shown that a site will vary significantly from one time period to another. Sample measurements on a roof of a large building showed a variation in transmitter activity of over 30% between 11:00 a.m. and 2:00 p.m.

Uptime relates to all of the transmitter activity of a site. Uptime can seldom be predicted or characterized precisely and thus usually must be measured. The amount of Uptime directly affects the EME exposure levels on a site.

In the consideration of site activity, there is an upper level of 100% uptime or when all transmitters are keyed and actually energized. Actual usage would be the most accurate consideration, but least practicable to implement. Actual usage varies greatly over time and antenna. Each antenna has an uptime characteristic based on density of combining, transmitter usage and activity.

While the use of Uptime could provide a better approach to predicting the actual levels that could be encountered, it proves to be impractical. Determining the Uptime characteristics can be very complex and change with time. Only by constantly monitoring and adjusting the model can uptime be used. Uptime cannot be theoretically calculated, it must be measured. Measurement of uptime involves high speed scanning of frequencies over a long period of time. Only after thousands of activity observations taken over days of monitoring will the worst case, actual and instantaneous uptime be understood. This complex procedure creates uncertainty. Practically, the uptime that should be used in the analysis of complex sites usually is 100% or total uptime.

A.3.8 Antenna Site Documentation

Any evaluation is only as accurate as the data used to make the evaluation. Antenna site documentation is important and **shall** be done in a standardized manner. For the analysis of EME fields, there are two methods of documentation. One proves to be considerably more exact but both allow an engineer to understand the EME situation and apply the proper compliance procedures, if necessary.

A.3.8.1 Actual Documentation

Actual documentation provides an accurate picture of the site situation. Actual documentation can be used by engineers for purposes other than EME analysis. Proper documentation requires a detailed description of transmitters, cable, antennas and location on the tower. Specifically, the following information is required:

- Transmitter frequency by antenna mount
- Power out of transmitter
- Network loss between transmitter and antenna
- Antenna characteristics and specifications
- Antenna location and standoff
- Uptime characteristics
- Areas frequented by personnel
- Layout of antenna field (roof or tower)

A.3.8.2 Categorization Documentation

Determining which transmitter is connected to which antenna on a site via which coaxial cable can be very expensive and in many cases is not necessary. Categorization documentation evolves determining the lowest loss coax and the highest-powered transmitter in any particular band. It is then assumed that all antennas for that band have this combination attached. By understanding the frequency, spacing, height and antenna characteristics of all antennas on the tower an approximation of the worst case EME situation can be determined. If this preliminary investigation proves to be compliant, then the actual situation will be compliant. Thus, this worst case scenario evaluation will assist in determining if a more detailed evaluation is required. This method of EME analysis requires a trained site auditor to only determine the components affecting EME compliance. This procedure will not provide the exact levels of the fields, but can be used to determine sites that require additional investigation using actual documentation.

**IMPORTANT**

Understanding the EME environment for a given site requires that an inventory of all generators of RF energy and the EME exposure potential be maintained for all facilities. This requires standardized documentation practices and regular updating.

A.4 Work Practices

The way an antenna site is managed, controlled and operated directly relates to the quality of the site. All of the customers on a site not only have physical investments, but also rely on uninterrupted service. The requirements placed on all contractors, customers and employees determine the quality of a site.

A.4.1 Training and Qualification Verification

A very specific part of worker contracting is verification of qualification and training. All contractors **shall** have a basic understanding of EME awareness and show an understanding of site standards. All contractors are expected to be experts in their field and to be fully aware of changes in governmental regulations. Without regular training a contractor cannot expect to be fully aware of changing hardware, technology and government regulations.

A.4.2 Physical Access Control

Antenna sites must have physical access control. The minimum requirement is locked gates to prevent vehicular access and locks on the facility. In most situations towers should have specific access control. Access to the site **shall not** allow access to the tower. Tower climbing prevention **shall** be accomplished with fencing around the tower, climb prevention on the tower or locking barriers on the tower. Unauthorized climbing must be prevented to ensure individuals climbing a tower understands the EME situation, are qualified and possess the correct climbing equipment. The facility should be equipped with card access, where appropriate, to provide a direct history of traffic at the site. Card access will provide specific information on who comes and goes from the site.

A.4.3 Policing

Any policy controlling site administration must be enforced before compliance can be assured. Every effort **shall** be given to ensuring all contractors understand, comply and support the policies of the site. Violation of policy **shall** be grounds for disqualification of a contractor. It is a privilege to work on a site and the policies must be followed.

A.4.4 Chain of Authority and Reporting Requirements

There should be site books or a site folder located at each facility. These documents will outline the policies and procedures for the site including a contact roster for emergencies and notifications. Additionally, any specific site situations or policies can also be contained in the site book.

A.4.5 Understanding Site Responsibilities Under Shared Conditions

There are situations where occupancy and management of a site involves other agencies or entities. This may be a situation where a site is located on a building, collocated with broadcast companies, shared hilltop, and so on. In each of these situations, others can make decisions that can affect the safety and operation of the site. Every effort should be given to developing consolidated procedures that require the compliance of all parties. This protects their interests and safety as well as contractors and employees using the site. Control measures **shall** be coordinated to allow safe tower maintenance. When other transmitters are involved, power reduction, lock-out/tag-out or restricted time for maintenance may have to be used to assure RF exposure is controlled.

A.4.6 General Procedures

General procedures relate to normal practices that are common to all sites. These can be found posted at all sites on the “Guidelines for working in radio frequency environments” placard. These guidelines are:

- All personnel **shall** have Electromagnetic Energy (EME) awareness training
 - All workers entering a RF controlled area **shall** understand their potential exposure and steps they can take to reduce their EME exposure. Awareness is a requirement of all workers. This includes not only field engineers, maintenance technicians and site designers, but also others such as site acquisition personnel, building management and service oriented personnel (such as electrical, telephone, elevator and air conditioning mechanics as well as roof repair, painting and window washing crews).
 - The FCC report and Order specifically indicates the requirement to make personnel at a transmitter site “fully aware” of their risk of exposure. Awareness training increases worker sensitivity to potential exposure, thereby assisting proper compliance regarding exposure limits. Awareness can be given in different formats, some may be video, formal classroom and informal discussions.
- All personnel entering this site must be authorized

Only personnel who have been trained and understand the EME situation and other safety requirements associated with site work **shall** be allowed access without escorts. When untrained individuals access the sites, trained escorts are required.

- Obey all posted signs
 - This guideline emphasizes the importance of observing and understanding the instructions on posted signs at the transmitter site. All safety signs play an important role in any safety program and just as any of these signs convey a specific message related directly to safe work in a particular environment, postings at transmitter sites are no different. For example, certain areas may be designated “NO ACCESS” unless certain antennas are shut down.
 - It is important that these signs be understood and obeyed, to assure EME exposure below the FCC guidelines. The requirement for RF protective clothing for workers is another precaution that could be identified on signs designating areas of potential exposure in excess of FCC limits.
- Assume all antennas are active
 - Because most telecommunications transmissions are intermittent, the status of many transmitters that may be operating at a particular site will be unknown. It is important to assume that all antennas may be energized and to maintain a safe working distance from each of them.
 - Only with special instruments to detect the presence of RF energy can it be determined a particular antenna is not energized at any given moment. While EME measurement surveys may have been performed on the site, these surveys do not assure that a specific antenna is not active at a given time.
- Before working on antennas, notify owners and disable appropriate transmitters
 - Before working on an antenna, workers must ensure that all attached transmitters are deactivated. Most antennas at a transmitter site are being used for important communications. They may be used for emergency and safety purposes like fire protection, rescue dispatch and police communications. Although all attached transmitters must be turned off before touching and working on an antenna, in any case touching or working on an antenna **shall not** be attempted before contacting the owners or operators.
 - Coordinating with the individuals responsible for use of the transmitter will make sure that turning off the equipment will not cause a serious disruption of the service. Sometimes, this coordination may mean that the work will have to be performed at night or in the early hours of the morning. Lockout/Tagout tags should be used to make sure someone else does not inadvertently turn on the transmitter while work on the antenna is being performed.
- Maintain minimum 914 mm (3 ft) clearance from all antennas
 - Studies have shown that the EME fields close to two-way radio transmitting antennas can be strong enough to exceed the limits specified by the FCC guidelines. A 914 mm (3 ft) clearance is a practical approach to assure that exposure remains within FCC limits. This ensures a distance is always maintained unless work is required on an antenna.

- Work on a **specific** antenna **shall only** be accomplished after the attached transmitters have been turned off. A small increase in distance from an antenna can have a substantial effect on reducing the EME exposure. This is particularly important when working near other active antennas. This also applies when doing work on roof or tower mounted equipment like air conditioners, tower lights or window washing rigs.
- Do not stop in front of antennas
 - When moving about at the transmitter site workers **shall** avoid stopping near any antenna; they should continue on until they reach an area that is removed from their immediate vicinity. If they are going to take a break from work or have lunch, they should select a place on the roof that will provide as much distance between them and the nearest antennas as practicable.
 - When climbing a tower, workers should select rest points away from antennas. Workers should always try to keep below or behind antennas to minimize their exposure to the main beam of the antenna. By continuing to move past high EME fields the average exposure will be minimized.
- Use personal RF monitors while working near antennas
 - Special care must be exercised when working on or very near antennas. Although the EME fields cannot be sensed directly, transmitter activity can be detected close to an antenna with a personal RF monitor.
 - Wearing such a monitor will allow workers to ensure that all connected transmitters have been turned off before they begin maintenance. As they approach an antenna, if the monitor alarms, they **shall** get away from the antenna, determine which transmitters are still on and disable them.
- Never operate transmitters without shields during normal operation
 - Some work at antenna sites involves troubleshooting and repair of the radio transmitters. The shields within transmitter power amplifiers are there to prevent strong RF fields from radiating out of the transmitter cabinet. Operating the transmitter without shields could cause interference and exposure of the technician performing the service to EME levels in excess of the FCC guidelines.
 - While shields must be removed for many maintenance tasks, they **shall** always be properly reinstalled before returning the transmitter to normal operation.
- Do not operate base station antennas in equipment room
 - At any time, transmitting antennas **shall not** be operated inside the equipment rooms, even for short term testing. This includes mobile magnet mount antennas attached to the top of transmitter cabinets as temporary installations.
 - Using transmit antennas inside equipment rooms can increase the exposure to EME levels above FCC guidelines and create undesirable radio frequency interference.

A.4.7 Site Specific Procedures

Site specific procedures that are unique to a particular site may need to be available to assure compliance to the FCC Guidelines. These can include:

- Special access
- Potential high EME exposure situations
- Special maintenance procedures for antenna repair
- Maintenance procedures unique to the site
- Special security procedures
- Special reporting procedures related to other tenants and owners

A.4.8 Operating Procedures

The conduct of contractors should be controlled and coordinated by the antenna site manager. All contractors, whether customer controlled or contracted directly with the management, must follow specific procedures. These procedures relate to safe operations that will be followed during installation and maintenance of antenna systems. Site procedures will prevail over contractor accepted practices and standards. Contractors must follow the guidelines for the site.

A.5 Signage

Various signs may be required on antenna sites. The minimum requirement is to post an EME caution and/or warning signs, as appropriate, wherever EME levels can exceed those associated with a green zone. This sign **shall** be posted in a location that can be easily viewed by individuals that enter the areas of concern. Some areas that may be affected are building tops, towers, areas around broadcast, and so on. This assures notice and understanding that the area has active RF transmitters. The sign **shall** conform to the ANSI standards.

Posting of signs provides a convenient method to convey to individuals important information. While signs can be effective if used properly, they can convey the wrong message and create undue alarm if used incorrectly. For this reason different signs are recommended for specific applications. These signs represent the best methodology available in conveying important information.

The standards used in creating these signs are:

Signal word- This word designates the degree of safety alerting (for example: Warning, Caution and Notice).

Symbol - The advisory symbol for identifying incident electromagnetic energy consists of black wavefronts radiating from a stylized point source. This symbol is defined in ANSI Z535.3-2011.

Text Message - The text message **shall** convey three things:

- What the safety issue is
- What action should be considered
- What authority the issue is based upon

These are used to designate the possible issues that can be encountered at an antenna site. These signs have specific implementation guidelines as outlined in this section. Improper implementation could result in inaccurate information being conveyed or unnecessary alarm being created.

Examples of signs that have been implemented in the United States are shown in this section.

- Site Guidelines

The site guidelines are posted inside the equipment room to make all workers aware of the normal requirements for site operation. The major intent is to ensure that compliance is maintained at the site. Having the sign visually available informs and reminds all personnel and others who have proper access of the rules for the site. This also qualifies as awareness information. See Figure A-11 for an example.

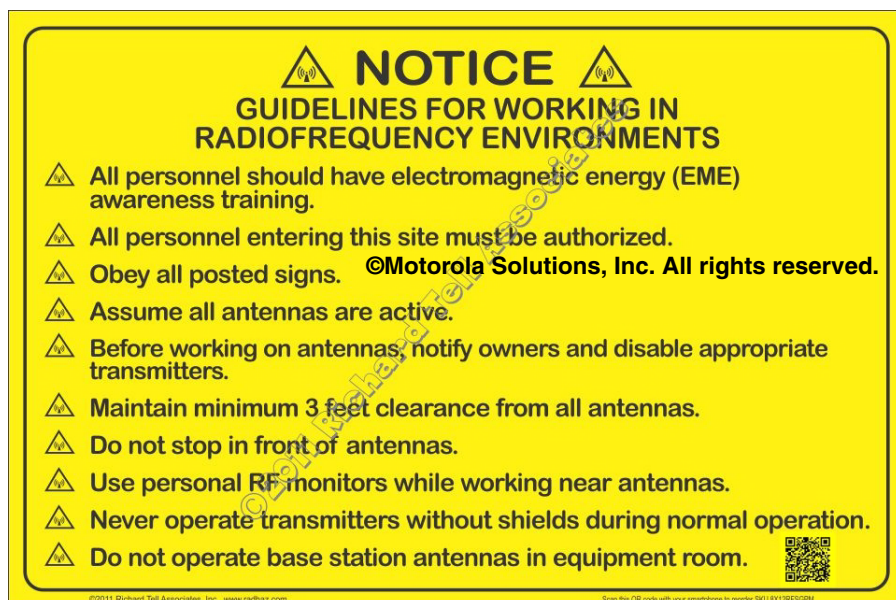

Figure A-11 Site Guidelines Placard

- **Notice**

The notice sign is used to distinguish the boundary between the General Population/Uncontrolled and the Occupational/Controlled areas. This boundary will usually be the fence for the property, gate entrance or roof door to the equipment room. The limits associated with this notification must be less than the Occupational/Controlled MPE. All sites have standard guidelines posted that must be obeyed and understood by all workers. These guidelines will ensure the area is maintained below Occupational/Controlled MPE. EME awareness training is recommended for all workers. See Figure A-12 for an example.



Figure A-12 Notice Sign

- **Caution**

The caution sign identifies RF controlled areas where RF exposure can exceed the Occupational/Controlled MPE. Generic guidelines apply in all situations and will be posted at all sites; however, site specific guidelines may be associated with some areas to ensure work is always performed in compliance with the FCC guidelines. Such site specific guidelines may require reduction of RF power before work begins or the use of RF protective clothing. In all cases workers **shall not** enter and work in these areas without understanding and obeying the necessary procedures. All authorized workers for RF controlled areas must have EME awareness training. See Figure A-13 for an example.



Figure A-13 Caution Sign

- Warning

The warning sign denotes the boundary of areas with RF levels substantially above the FCC limits, normally defined as those greater than ten (10) times the Occupational/Controlled MPE.

Telecommunication contractors and employees **shall not** enter these areas unless special procedures are followed. These situations typically are associated with broadcast transmitters operating at high power. If work is required in these areas, the broadcast transmitter must be shut down for the duration of the maintenance. Engineering evaluation must be performed to determine the proper special procedures required before this area can be entered. See Figure A-14 for an example.



Figure A-14 Warning Sign

A.6 Personal Protective Equipment (PPE)

A.6.1 Protective Clothing

There may be situations where field analysis shows areas that are not in compliance with the Occupational/Controlled MPE. After all options are considered and if the situation cannot be controlled with engineering or work practice solutions, implementation of Personal Protective Equipment (PPE) may be the only solution. An example of this type of situation may be a rooftop that has collocated broadcast in the vicinity of a heavily congested antenna field. In certain situations where building architectural concerns are a priority there may be no simple solution available to reduce the fields. The only solution may be the use of RF protective clothing as a means to reduce EME exposure.

RF protective clothing was introduced into the United States several years ago by a German manufacturer (NSP)¹ and sold under the name Naptex™. The suit consists of work coveralls with an integral hood for head protection. The suit is constructed of a polyester yarn, which is wound coaxially around stainless steel fibers. This provides uniform consistency of material and attenuating metal. Tests^{2,3} have shown that the suit can effectively provide between 10 dB and 12 dB of reduction in EME absorption within the body at virtually any frequency over the telecommunications spectrum. This would indicate that use of

1. See NSP Website: www.nspworldwide.com

2. Tell, R. A. (1995). *Engineering Services for Measurement and Analysis of Radio frequency (RF) Fields*. Technical report for the Federal Communication Commission, Office of Engineering and Technology, Washington, DC, FCC/OET RTA 95-01 [NTIS order no. PB95-253829].

the suit could compensate for exposure to EME fields as great as 1000% above the FCC Occupational/Controlled MPE values. Additional testing has shown the use of the suit without the hood in fields under 300% of the Occupational/Controlled MPE values at 900 MHz provides compliance with the peak SAR limits of 8 W/kg. The acceptable levels that the hoodless suit can be safely used increase as the frequency is reduced. Contractors **shall** be notified if RF Protective Clothing or the hood is required for compliance.

A.6.2 Personal Monitors

Work on specific antennas **shall only** be accomplished after the appropriate transmitters have been turned off and locked out. This prevents anyone from accidentally activating the transmitters while others are performing maintenance. However, with the large number of transmitters combined into single antennas it becomes considerably more difficult to confirm that all transmitters are deactivated. The ideal method would be to have a RF light on the top of the antenna. The light would be off to confirm that there was no RF activity. A more practical approach would be to use a personal monitor. A personal monitor is an RF threshold detector that alarms when RF exceeds the threshold of the device, normally 50% Occupational/Controlled MPE. These devices are designed to detect a wide range of frequencies and can be used in most environments. When approaching an antenna that requires maintenance, the monitor **shall** be placed near the antenna for a period of time, about 30 seconds should suffice. If the antenna is still active the monitor will alarm. This will show that there are still transmitters active, or if an alarm does not sound, will confirm that all transmitters were deactivated. This provides a positive confirmation and allows the worker to ensure they are working on inactive antennas.

Some manufacturers of personal monitors propose they can be worn to indicate compliance. This use should be considered carefully because, when the device is used in accordance with its instructions, compliance is only confirmed at the location of the monitor. If, for example, the monitor is worn on the belt of a tower climber, the possibility of entering high fields without the monitor being activated exists. When climbing the head and shoulders can enter high fields without the monitor mounted on the belt alarming. This could provide a false indication of safety.

A.7 EME Action Thresholds Summary

Table A-2 summarizes the actions needed to be taken at the various EME thresholds.

Table A-2 EME ACTION THRESHOLDS

Control-led MPE	Post Warning Sign	Only broadcast contractors allowed
1000%		

3. Tell, R. A. (1996). *SAR Evaluation of the Naptex suit for use in VHF and UHF bands*. Presented at the International RF Safety Workshop, Schwangau, Germany, September 25-26.

Table A-2 EME ACTION THRESHOLDS (CONTINUED)

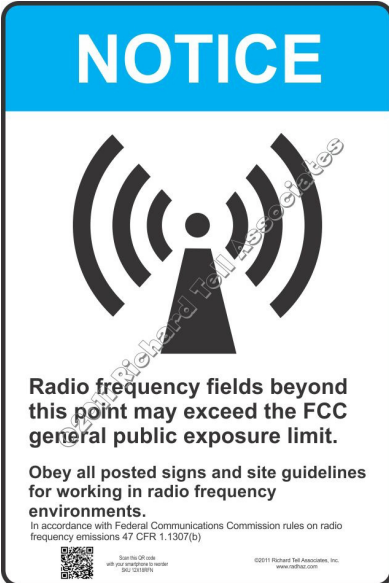
<p>300%</p>		<p>EME protective hood High level EME site-specific awareness Post Caution sign EME protective coveralls Site-specific EME awareness</p>	<p>RF qualified and trained workers allowed</p>
<p>100%</p>		<p>Post Notice sign Post EME Site Guidelines General EME awareness</p>	<p>General site workers allowed</p>
<p>20%</p>		<p>No procedures required</p>	<p>General public allowed</p>

Soil Resistivity Measurements

Soil resistivity directly affects the design of a grounding (earthing) electrode system and is the prime factor that determines the resistance to earth of a grounding electrode or grounding electrode system. Therefore, prior to the design and installation of a new grounding electrode system, the proposed location **shall** be tested to determine the soil's resistivity. See BS 7430:2011, IEEE 81-2012 and MIL-HDBK-419A for more information.



NOTE

The terms “grounding” and “earthing” are used interchangeably throughout this appendix. The terms “ground resistance tester” and “soil resistivity tester” are used interchangeably throughout this appendix.

B.1 Safety



WARNING

To help reduce the risk of electrical shock from buried or unseen power sources, observe all manufacturer's safety information when using the ground resistance tester. See IEEE 81-2012, section 5.1, for additional safety precautions and information.



WARNING

To help protect against shock hazard, insulated electrician's footwear and gloves **SHALL** be worn while performing soil resistivity testing.



WARNING

To help prevent eye injury, always wear eye protection when striking ground rods with a hammer.



IMPORTANT

Refer to NFPA 70E[®], *Standard for Electrical Safety in the Workplace*[®] for additional electrical safety information.

Procedures in this appendix **shall not** be performed by untrained or unqualified personnel, nor are any procedures herein intended to replace proper training. It is required that personnel attempting to measure the resistivity of soil receive prior formal training on the subject and on its associated safety hazards. All applicable laws, rules and codes regulating the work on electrical systems **shall** be complied with at all times.

All safety warnings and cautions provided in this appendix and included in the documentation provided with the ground resistance tester **shall** be followed at all times.

B.2 Soil Resistivity Variability and Factors Affecting Soil Resistivity

Soil resistivity varies widely by region due to differences in soil type and changes seasonally due to variations in the soil's electrolyte content and temperature. Therefore, it is recommended that these variations be considered when assessing soil resistivity. To help ensure expected grounding (earthing) electrode system resistance values are achieved throughout the year, worst-case soil resistivity values should be considered when designing a grounding electrode system.

Table B-1 lists ranges of soil resistivity for various types of soil. The values are the expected values that should be seen when measuring soil resistivity (see IEEE 142-2007, Table 4-2 for more details).



NOTE

An ohm-centimeter ($\Omega\text{-cm}$) is the resistance in ohms (Ω) of one cubic centimeter of soil, measured from opposite sides of the cube.

Table B-1 SOIL RESISTIVITY FOR VARIOUS SOIL TYPES

Soil Type	Resistivity ($\Omega\text{-cm}$)		
	Minimum	Average	Maximum
Ashes, brine or cinders	590	2,370	7,000
Concrete (below ground)	--	3,000	--
Clay, gumbo, loam or shale	340	4,060	16,300
Clay, gumbo, loam or shale with varying portions of sand and gravel	1,020	15,800	135,000
Gravel, sand or stone with little clay or loam	59,000	94,000	458,000



NOTE

"Gumbo" is soil composed of fine-grain clays. When wet, the soil is highly plastic, very sticky and has a soapy appearance. When dried, it develops large shrinkage cracks.

The resistivity of soil is primarily determined by the electrolyte content of the soil. Electrolytes consist of moisture, minerals and dissolved salts. In general, soil resistivity decreases (improves) as electrolytes increase. Table B-2 and Figure B-1 show soil resistivity changes as a function of soil moisture content. The resistivity of the soil decreases rapidly as the moisture content increases from very little moisture to approximately 15 percent moisture (see IEEE 142-2007, Table 4-3 for more details).

Table B-2 SOIL RESISTIVITY CHANGES AS A FUNCTION OF SOIL MOISTURE

Moisture Content (by weight)	Resistivity ($\Omega\text{-cm}$)	
	Top Soil	Sandy Loam
0%	$> 10^9$	$> 10^9$
2.5%	250,000	150,000
5%	165,000	43,000
10%	53,000	18,500
15%	19,000	10,500

Table B-2 SOIL RESISTIVITY CHANGES AS A FUNCTION OF SOIL MOISTURE

Moisture Content (by weight)	Resistivity (Ω -cm)	
	20%	12,000
30%	6,400	4,200

Source: *Soares Book on Grounding and Bonding*, 9th addition (ISBN 1890659-36-3).

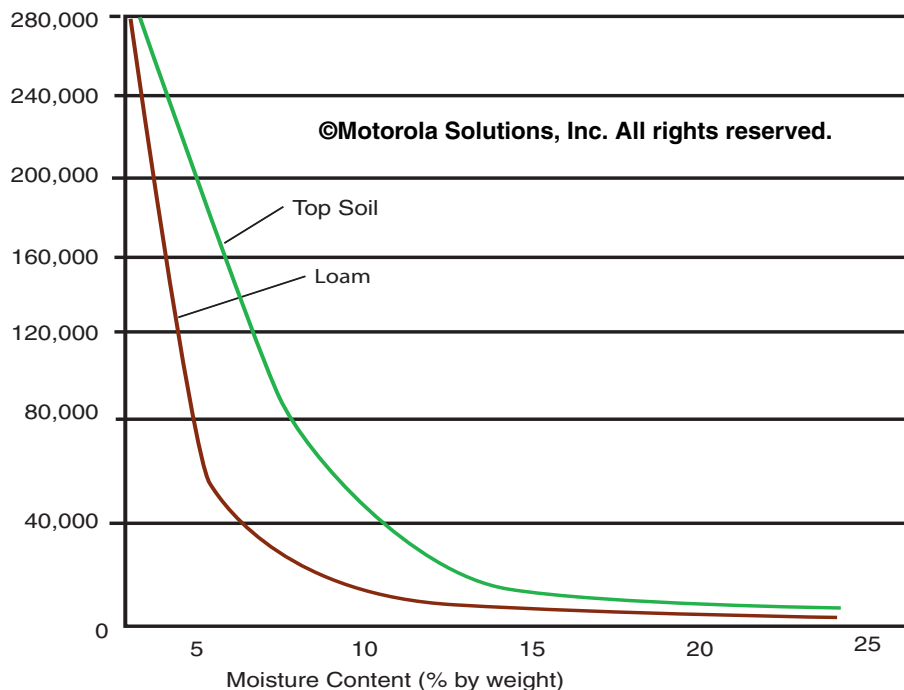
**Figure B-1** Soil Resistivity as a Function of Soil Moisture

The resistivity of soil is also affected by its temperature. In general, soil resistivity increases as temperature decreases. Table B-3 and Figure B-2 show soil resistivity changes as a function of soil temperature. As shown, the greatest rate of change in soil resistivity is at the point where moisture in the soil freezes (see IEEE 142-2007, Table 4-4 for more details).

Table B-3 SOIL RESISTIVITY CHANGES AS A FUNCTION OF SOIL TEMPERATURE

Temperature		Resistivity (Ω -cm)
$^{\circ}$ C	$^{\circ}$ F	
20	68	7,200
10	50	9,900
0 (water)	32 (water)	13,800

Source: *Soares Book on Grounding and Bonding*, 9th addition (ISBN 1890659-36-3).

Table B-3 SOIL RESISTIVITY CHANGES AS A FUNCTION OF SOIL TEMPERATURE

Temperature		Resistivity
0 (ice)	32 (ice)	30,000
-5	23	79,000
-15	14	330,000

Source: *Soares Book on Grounding and Bonding*, 9th addition (ISBN 1890659-36-3).

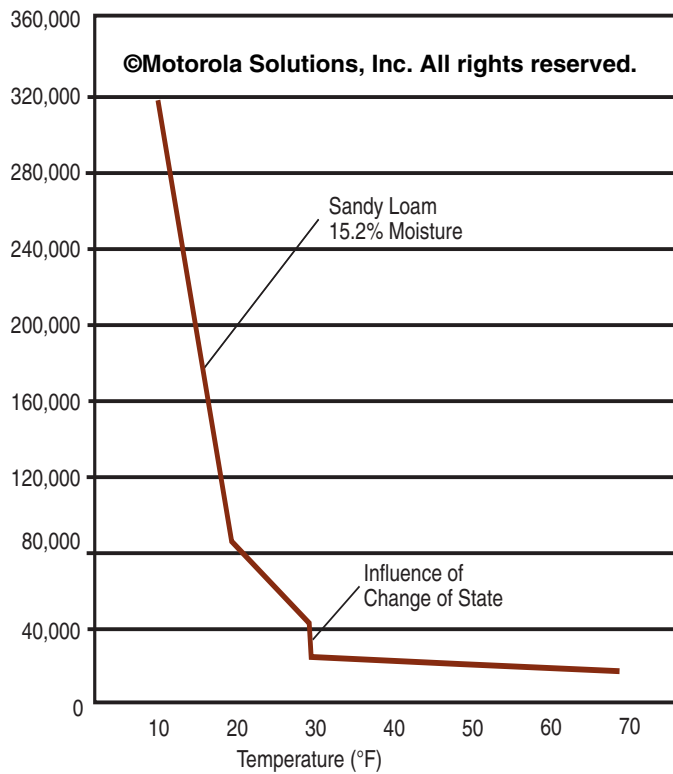
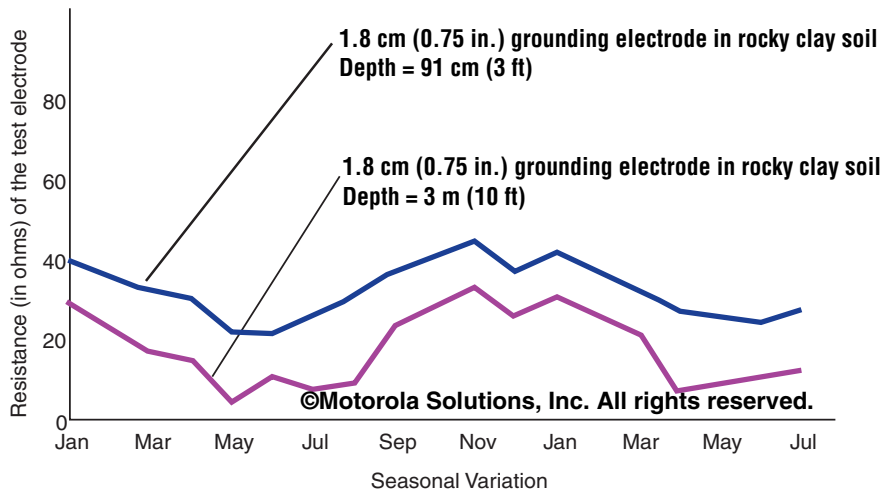

Figure B-2 Soil Resistivity as a Function of Soil Temperature

Because the resistivity of soil is directly affected by its moisture content and temperature, it is reasonable to conclude that the resistance of any grounding electrode system will vary throughout the different seasons of the year. Figure B-3 shows the seasonal variations of the resistance to earth of a grounding electrode.



Source: Soares Book on Grounding and Bonding, 9th addition (ISBN 1890659-36-3).

Figure B-3 Seasonal Variations in Grounding Electrode Resistance

Temperature and moisture content both become more stable as distance below the surface of the earth increases. Therefore, in order to be effective throughout the year, a grounding electrode system should be installed as deep as practicable. Best results are achieved when ground rods or other grounding electrodes, reach permanent moisture.

B.3 Testing Methods

Two methods of obtaining soil resistivity data are typically used, as follows:

- Four-point (Wenner) method (see BS 7430:2011, FAA-STD-019e, IEEE 81, MIL-HDBK-419A and NWSM 30-4106 for more information).
- Random core samples

Where practicable, the testing should be performed using the four-point testing method; this is the method described in this appendix. The area indicating the lowest soil resistivity will be the optimum location for placement of the grounding (earthing) electrode system. A suggested best practice is to perform the test during different seasons of the year whenever practicable. The worst-case measured soil resistivity should then be considered in order to design a grounding electrode system that will meet the resistance design goal throughout the year.

Random core sampling should be used only when the four-point test cannot be accomplished, such as in metropolitan areas, areas where buried metallic objects may cause misleading readings, or where surface area is insufficient for proper test performance. Random core sampling **shall** be performed by a geotechnical firm. The random core sample test results can then be used in “Interpreting Test Results” on page B-11 or provided to an engineering firm so they can design an appropriate grounding electrode system.



NOTE

The same core samples taken for foundation design can also be used for conducting the random core sample testing.

Core samples should be taken from at least five different test areas as shown in Figure B-5 at depths of 1.5, 3 and 6.1 m (5, 10 and 20 ft). See FAA-STD-019e, section 4.2.4.2, and NWSM 30-4109, section 2.8.1, for more information.

B.4 Site Preparation Considerations



IMPORTANT

Do not test an adjacent location if the site location is inaccessible when the testing is scheduled. Reschedule the test so it can be done on the actual site. Significant differences may exist between adjacent sites.

Soil resistivity tests must be performed on the actual site, after the following preparation and conditions have been met:

- The site has been leveled to where the foundation will be placed.
- Soil added to the site is satisfactorily compressed before conducting the test, so it will behave as undisturbed soil.
- No precipitation has occurred within 72 hours.

B.4.1 Required Test Equipment and Supplies

The required test equipment and supplies for performing a soil resistivity test are as follows:

- Ground (Earth) Resistance Tester designed for four-point testing, including all necessary accessories. Accessories should include the following at minimum:
 - Operator or User Manual
 - Four test rods (typically supplied with tester)

The test rods should be stainless steel, 610 mm (24 in.) maximum length, 16 mm (0.375 in.) diameter, utilizing a preferred surface penetration of 229 mm (9 in.). Test rods typically come with a four-point testing kit, in lengths from 381 mm (15 in.) to 610 mm (24 in.).

- Four test leads (typically supplied with tester)

The test leads connect the tester to the test rods. If the leads do not use labels or different colors to correlate the test lead connections between the rods and tester terminals, use tags or four different colors of tape to correlate the connections.



IMPORTANT

The connections must be kept in the correct order to maintain symmetry of testing procedures and maintain consistent results.

- Small sledgehammer
- Tape measure
- Safety glasses
- Gloves
- A photocopy of Table B-6, for recording and keeping track of several measurements across the site.

B.4.2 Performing Soil Resistivity Test

Perform the test at the location where the site will be built. This procedure describes how to obtain test results for various depths and how to measure the soil resistivity over the entire site.



WARNING

Follow the manufacturer's warning and caution information when using the ground resistance tester.



IMPORTANT

Buried underground metallic objects such as pipes, cables, conductors or tanks can provide an alternate path for test current from a ground resistance tester (soil resistivity tester), resulting in inaccurate measurements. Chain-link fencing, concrete with rebar and other electrically continuous objects above grade and parallel to the test also provide an alternate path for the test current. Therefore, do not test in areas with these metallic objects.

B.4.2.1 Measuring At Various Depths

The soil is typically not homogeneous from the surface to the depth being tested and resistivity varies at different depths. Because of this, the four-point test (performed at various depths and at various locations throughout the site) is used to provide a composite result of the soil resistivity.

The testing depth of a soil resistivity test is determined by the spacing between the four test rods which correspondingly connect to the appropriate terminals on the tester. The recommended practice is to test the soil at various depths in order to determine the best depth for the grounding (earthing) electrode system. For example, if the test rods are 1.52 m (5 ft) apart, the measurement is an average of the soil from the surface down to 1.52 m (5 ft). As the spacing between the rods is increased, results for correspondingly deeper samples are directly obtained. Table B-4 lists the soil depths measured for different rod spacing distances.

Table B-4 SOIL DEPTH MEASURED AS A FUNCTION OF ROD SPACING

Rod Spacing	Soil Depth Measured
1.52 m (5 ft)	1.52 m (5 ft)
3 m (10 ft)	3 m (10 ft)
6.1 m (20 ft)	6.1 m (20 ft)
9.1 m (30 ft)	9.1 m (30 ft)
12.2 m (40 ft)	12.2 m (40 ft)

B.4.2.2 Testing Theory and Rod Arrangement



NOTE

The calculated soil resistivity is the average soil resistivity between the soil surface and the depth of the soil equivalent to the rod spacing.



NOTE

The tester terminals may be labeled differently on different tester models. See the tester's User Manual for details.

The following tester terminal naming conventions are typical:

- C1, P1, P2 and C2 (the naming convention used throughout this appendix)
- X, Xv, Y and Z
- E, ES, S and H

Table B-5 shows the relationships among tester naming conventions that are commonly used.

Table B-5 COMMONLY USED TESTER NAMING CONVENTIONS

Current Probe 1	Potential/Voltage Probe 1	Potential/Voltage Probe 2	Current Probe 2
C1	P1	P2	C2
X	Xv	Y	Z
E	ES	S	H

Figure B-4 shows the rod arrangement required for testing. The test requires inserting four test rods into the test area, in a straight line, equally spaced and all at a depth of 229 mm (9 in.). A constant current is injected into the earth from the earth resistance tester through the two outer test rods C1 and C2. The voltage drop resulting from the current flow through the earth is then measured across the inner two test rods P1 and P2.

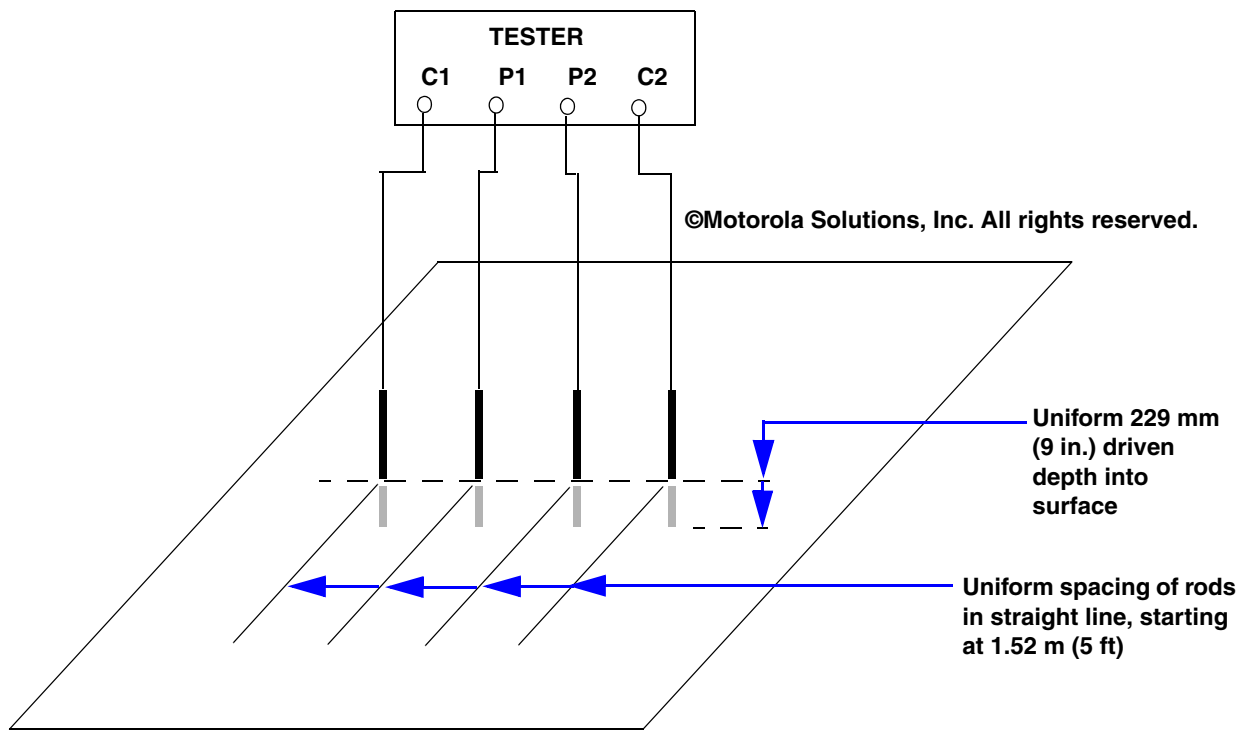

Figure B-4 Rod Arrangement and Spacing

Newer testers display the soil resistivity (ρ) reading directly in Ω -cm, but some older testers display the soil resistivity reading in ohms (Ω). In this case, soil resistivity (ρ) of the tested area must be calculated using the tester value in ohms and one of the following formulas:

$$\rho = 191.5 \times A \times R$$

Where:

ρ = soil resistivity in Ω -cm

A = Distance between test rods (in feet)

R = Resistance obtained from tester (in ohms)

$$\rho = 628 \times A \times R$$

Where:

ρ = soil resistivity in Ω -cm

A = Distance between test rods (in meters)

R = Resistance obtained from tester (in ohms)

B.4.2.3 Samples Required to Develop Accurate Site Resistivity Profile

Because stray currents, buried water pipes, cable sheaths and other factors usually interfere and distort the readings, measurements should be taken along at least four directions (see FAA-STD-019e, section 4.2.4.2, and NWSM 30-4106, section 2.8.1). Figure B-5 shows the recommended multiple sampling pattern to develop an accurate profile.



NOTE

The more divergent the samples taken, the more accurate the generated soil model will be.

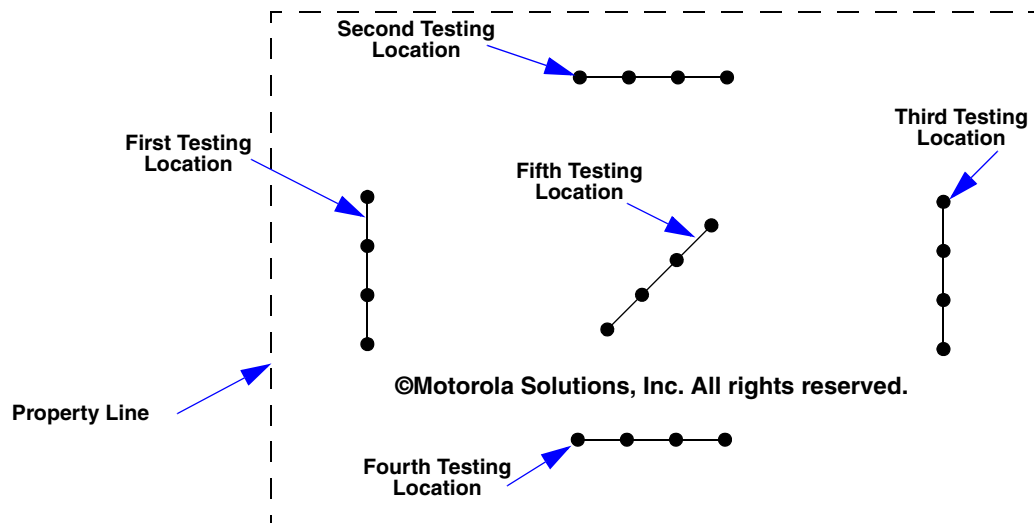

Figure B-5 Recommended Multiple Sampling Pattern Across Site

B.4.2.4 Testing Tips

The test directions must be carefully chosen so they do not parallel any buried metallic objects. Buried metallic objects could affect the measurements because they could provide an alternate path for the test current. Buried objects include, but are not limited to, water pipes, conduits, cables, tanks, metallic fences or metal rebar within concrete footings.

Select a test direction that is not close to or in parallel with overhead high-voltage lines located nearby. Overhead power lines could induce noise into the meter, creating an invalid measurement. If testing in close proximity to overhead high-voltage lines is unavoidable, ensure that the test direction and tests leads are perpendicular to the overhead lines to help minimize induced noise. Noise induction can be further reduced by twisting the test leads together (see the meter's User Manual for more information).

To ensure good contact with the earth, compact the soil directly around the test rods to remove air gaps formed when inserting the rod. If the reading is not stable or displays an error indication, double-check the connection and the meter range setting. If the range is correct, try adjusting the test current. An effective way of decreasing the test rod resistance to earth is by pouring water (or sports drink, which is high in electrolytes) around the rod, as illustrated in Figure B-6. The addition of moisture helps achieve a better electrical connection and does not influence the overall results.

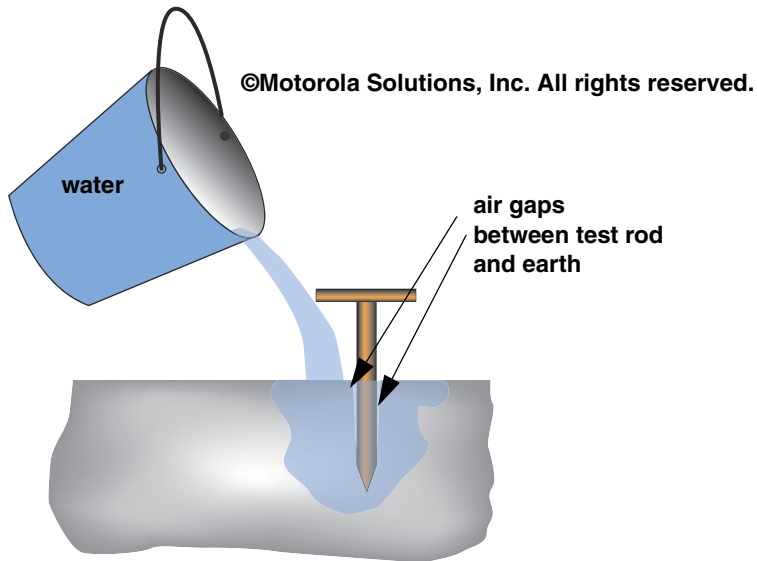

Figure B-6 Improving Electrical Contact by Adding Water to the Soil

B.4.2.5 Soil Resistivity Measurement Procedure



WARNING

Follow the manufacturer's warning and caution information when using the ground resistance tester.



IMPORTANT

Review the tester's User Manual prior to performing the following tests.

Perform the following procedure to obtain soil resistivity readings.

1. On tester, verify that the jumper strap between the C1 and P1 terminals is disconnected (if applicable).
2. Starting at the "First Test Location" shown in Figure B-5, drive four test rods into the soil to a depth of 229 mm (9 in.), in a straight line and spaced 1.52 m (5 ft) apart (as shown in Figure B-4).



IMPORTANT

The test rods must be connected in the order specified in Step 3. If the test rods are connected incorrectly an inaccurate reading will result.

3. Using test leads, connect the C1, P1, P2 and C2 terminals to their respective test rods, as shown in Figure B-4.
4. Turn the tester on. Press the test button and read the display.
 - If the reading is not stable or displays an error indication, double-check the connection and the meter range setting.
 - If the range is correct, try adjusting the test current. An effective way of decreasing the test rod resistance to earth is by pouring water or sports drink around the rod. The addition of moisture is insignificant; it will only achieve a better electrical connection and will not influence the overall results.

5. Record the measurement obtained in the appropriate “Meter Readings” space on the photocopy of the “Soil Resistivity Worksheet” on page B-15.
6. Remove the test rods from the soil.
7. In the same location on the site and along the same line as previous test, repeat steps 2 through 6 for remaining spacings listed on the Soil Resistivity Worksheet.
8. Prepare to take measurements for the next test location shown in Figure B-5. Repeat steps 2 through 7 for this location.
9. Repeat steps 2 through 8 for all remaining test locations specified in Figure B-5.
10. On the Soil Resistivity Worksheet copy, calculate and record soil resistivity (ρ) for each of the 25 readings taken in the steps in this procedure.

B.4.3 Interpreting Test Results

Depending on the type of grounding electrode system to be installed, proceed to one of the following subsections. Test results are interpreted according to MIL-HDBK-419A.

- “Calculating Single Ground Rod System Resistance” on page B-11
- “Calculating Grounding Electrode System Resistance With Multiple Ground Rods in a Straight Line” on page B-19
- “Calculating Grounding Electrode System Resistance With Multiple Ground Rods in Ring Configuration” on page B-22
- “Calculating Grounding Electrode System Resistance With Ground Rods in Grid Configuration” on page B-23



IMPORTANT

Calculations in the following sections require the ground rods to be installed vertically. Ground rods installed horizontally or partially horizontal require more complex calculations and are beyond the scope of this appendix.



NOTE

The interpreted test results are typically conservative because the effects of the horizontal connecting conductors (typically ground rings) are not considered in the following calculations. Consideration of the horizontal connecting conductors requires complex calculations that are beyond the scope of this manual. An engineering firm may be required to perform calculations that consider the effects of the horizontal connecting conductors.

B.4.3.1 Calculating Single Ground Rod System Resistance

For a single ground rod, the resistance can be easily calculated using a nomograph. Example calculations are shown in Figure B-7 (Sheets 1 through 3). The resistance of a single ground rod can also be calculated using the [Single Ground Rod Resistance Calculator](#) tool provided with this manual.

If calculations show excessive resistance for a given rod length and diameter, recalculate substituting a larger diameter rod and/or longer rod. In this manner, the proper ground rod size and length for a particular site can be determined. Figure B-9 Sheet 3 shows an example where resistance to earth is improved by substituting a longer rod of larger diameter.



NOTE

Increasing the length of a rod has significantly more impact on the resistance to earth than increasing the diameter.

Perform the following procedure to calculate the resistance of the single grounding electrode.

1. Make a photocopy of Figure B-10.

2. On **d** scale of nomograph, plot a point corresponding to the diameter of the ground rod to be used.
3. On **L** scale of nomograph, plot a point corresponding to the length of ground rod to be used.
4. Draw a line connecting the **d** and **L** points.
5. Plot **ρ** value from Soil Resistivity Worksheet on the **ρ** scale of nomograph.



NOTE

The **ρ** value used in this step should be selected according to the desired ground rod length. For example, a 3 m (10 ft) ground rod would use the value measured with a 3 m (10 ft) spacing (test depth) and a 6 m (20 ft) ground rod would use the value measured with a 6 m (20 ft) spacing (test depth). An exact **ρ** value may not always be available for the desired ground rod length. In these cases use the closest value available or perform additional tests for the desired ground rod length.

6. Where the line connecting the **d** and **L** points intersects the **q** line, draw a new line from this point to the point plotted on the **ρ** scale. Extend this line to the **R** scale. This is the resistance for a single ground rod.

B.4.3.1.1 Example Worksheet and Nomograph

Figure B-7 (Sheets 1 through 3) shows example readings and calculations from a completed worksheet and nomograph.

- Sheet 1 shows example readings, as entered from field Ground Resistance Tester measurements and the resulting Soil Resistivity calculations.
- Sheet 2 shows an example of a completed nomograph.
- Sheet 3 shows a second nomograph filled-in with calculations for grounding electrode resistance improvement using a larger-diameter and longer rod.

Location “1 of 5” 3 m (10 ft) spacing is measured on Ground Resistance Tester. In this example, tester reads “2.1 Ω”.

“2.1” is written in “Meter Readings” column for Location “1 of 5” (10 ft spacing) in Worksheet.

ρ value for Location “1 of 5” 10 ft spacing is calculated using formula on Worksheet.

ρ value of “4021.5” is written in “Soil Resistivity Calculations” column for Location “1 of 5” (10 ft spacing) in Worksheet.

Location	Spacing (Test Depth)	
	1.52 m (5 ft)	3 m (10 ft)
Meter Readings (steps 2 through 5)		
of 5	4.2	2.1
of 5	4.5	2.5
of 5	4.2	2.3

©Motorola Solutions, Inc. All rights reserved.

	$\rho = 4021.5$	$\rho = \mathbf{4021.5}$
	$\rho = 4308.8$	$\rho = 4787.5$
	$\rho = 4021.5$	$\rho = 4404.5$

Figure B-7 Example Worksheet and Nomograph (sheet 1 of 3)

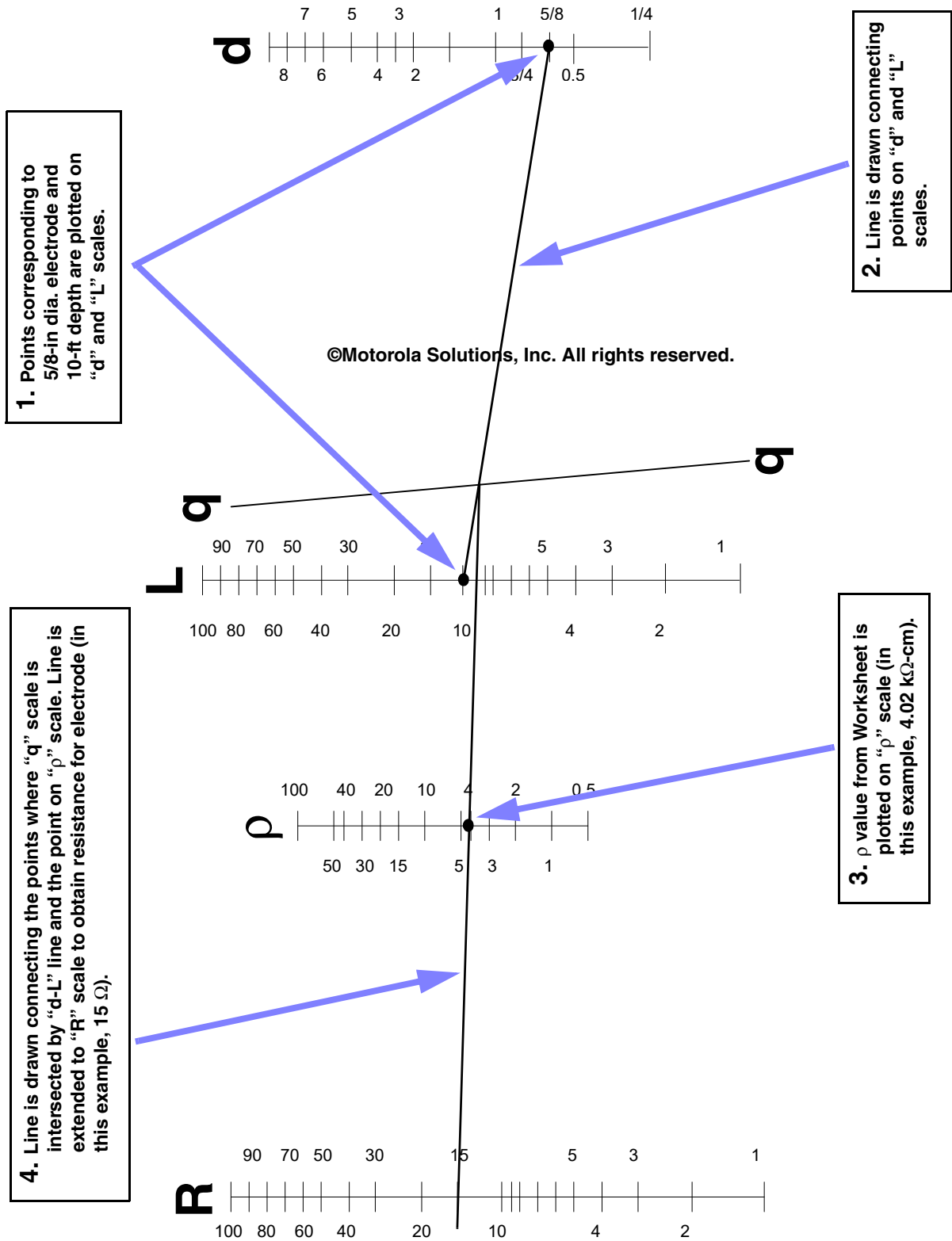

Figure B-8 Example Worksheet and Nomograph (sheet 2 of 3)

©Motorola Solutions, Inc. All rights reserved.

Plotted values for 19 mm (3/4 in.)
 electrode at 20-ft depth for same
 meter reading shows lower electrode
 resistance (7.5 Ω in this example, vs.
 15 Ω in previous example).

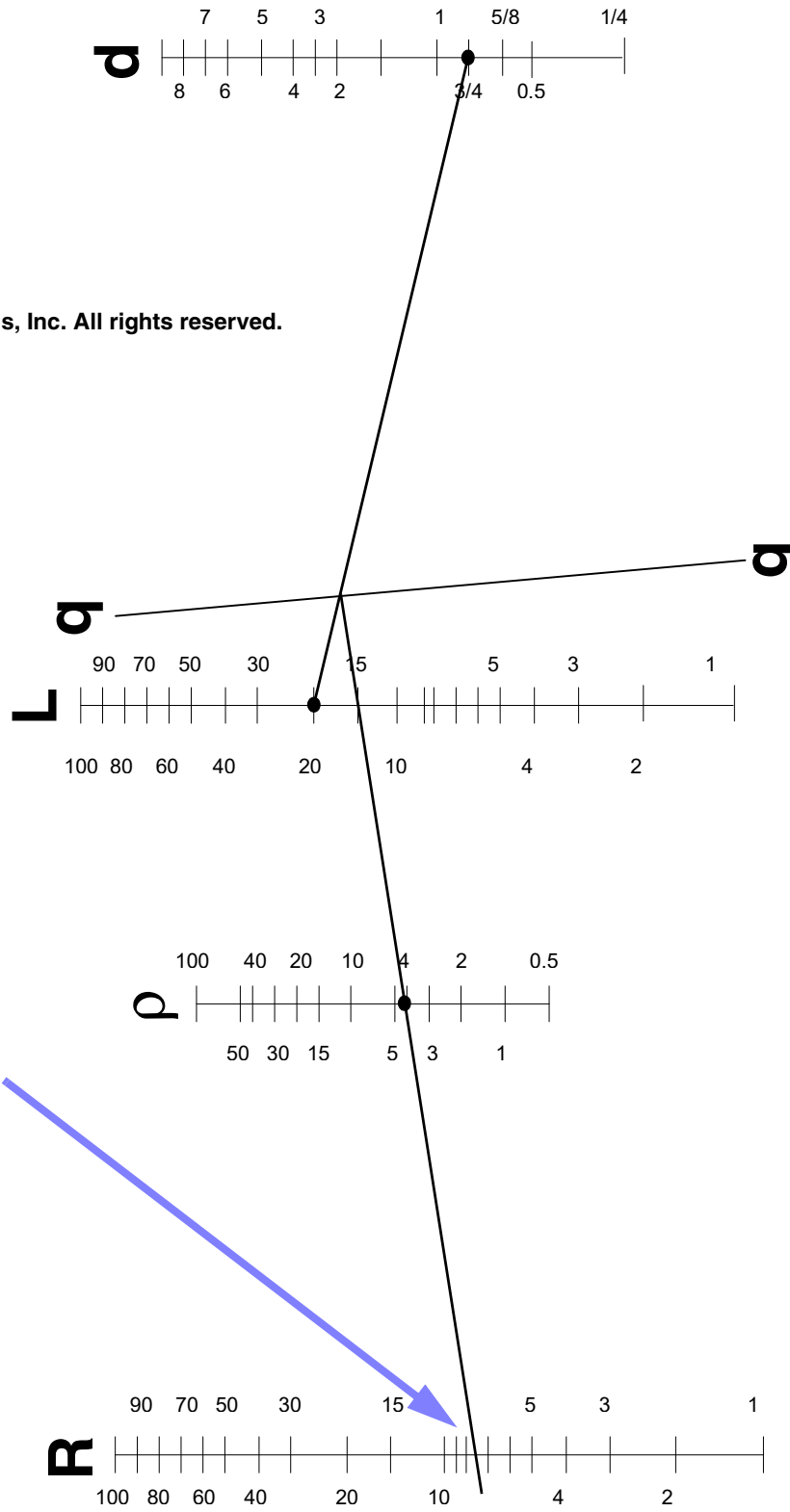
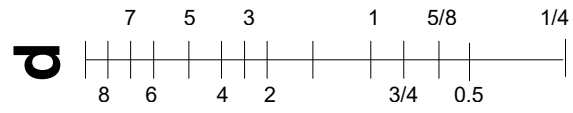

Figure B-9 Example Worksheet and Nomograph (sheet 3 of 3)

Table B-6 SOIL RESISTIVITY WORKSHEET

Location	Spacing (Test Depth)				
	1.52 m(5 ft)	3 m(10 ft)	6.1 m(20 ft)	9.1 m(30 ft)	12.2 m(40 ft)
Meter Readings (steps 2 through 5)					
1 of 5					
2 of 5					
3 of 5					
4 of 5					
5 of 5					
Soil Resistivity Calculations (step 10)					
$\rho = 191.5 \times A \times R$ $\rho =$ soil resistivity in Ω -cm $A =$ Distance between test rods (in feet) $R =$ Resistance obtained from tester			OR	$\rho = 628 \times A \times R$ $\rho =$ soil resistivity in Ω -cm $A =$ Distance between test rods (in meters) $R =$ Resistance obtained from tester	
1 of 5	$\rho =$	$\rho =$	$\rho =$	$\rho =$	$\rho =$
2 of 5	$\rho =$	$\rho =$	$\rho =$	$\rho =$	$\rho =$
3 of 5	$\rho =$	$\rho =$	$\rho =$	$\rho =$	$\rho =$
4 of 5	$\rho =$	$\rho =$	$\rho =$	$\rho =$	$\rho =$
5 of 5	$\rho =$	$\rho =$	$\rho =$	$\rho =$	$\rho =$
Test completed by:			Notes:		
Date:					
Client / Project:					
Site Location/ID:					
Ground Resistance Tester Model: _____ S/N: _____ Calibration date: _____					
Soil Description:					
Ambient Conditions Temperature: _____ Present conditions (dry, rain, snow): _____ Date of last precipitation: _____					

THIS PAGE INTENTIONALLY LEFT BLANK.



©Motorola Solutions, Inc. All rights reserved.

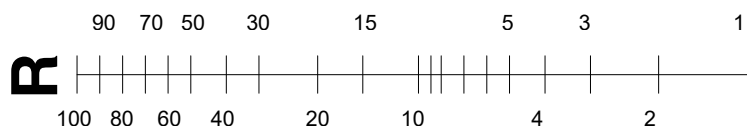
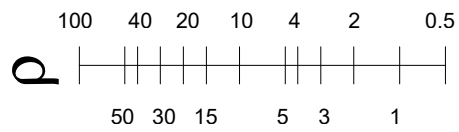
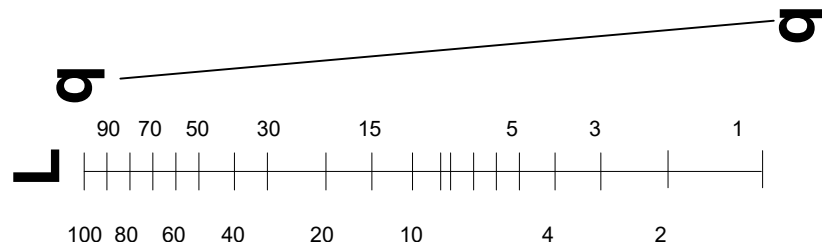

Figure B-10 Soil Resistivity Nomograph

THIS PAGE INTENTIONALLY LEFT BLANK.

B.4.3.2 Calculating Grounding Electrode System Resistance With Multiple Ground Rods in a Straight Line

For a grounding (earthing) electrode system with multiple ground rods in a straight line (as shown in Figure B-11), the system resistance can be calculated as described in the following procedure. The resistance of multiple ground rods in a straight line can also be calculated using the [Parallel Ground Rod Resistance Calculator](#) provided with this manual.

1. Perform soil resistivity test as described in “Soil Resistivity Measurement Procedure” on page B-10.
2. Calculate the resistance of one ground rod as described in “Calculating Single Ground Rod System Resistance” on page B-11. The ρ value used in this step should be from a test location located in the same area as the intended parallel ground rods installation. Write down this number.
3. Sketch a proposed layout of the ground rod arrangement using equally spaced rods in a line.



NOTE

The stipulations regarding rod spacing specified in “Grounding (Earthing) Electrodes” on page 4-8 must be observed when planning rod layout.

4. Make a photocopy of “Combined Resistance Graph (Ground Rods Arranged in Line or Ring)” on page B-21.
5. Using the copy of Combined Resistance Graph (Ground Rods Arranged in Line or Ring), calculate the effective resistance of the proposed layout as follows:
 - 5.1 Noting the number of rods to be used, locate this number on the Number of Rods axis of the graph.
 - 5.2 Note the spacing of the rods in the proposed layout in terms of spacing as related to length of rods. In graph, “ $s=L$ ” is spacing equal to length of rod “ $s=2L$ ” is spacing equal to twice the length of rod and so on. Locate the spacing line on graph ($s=L$, $s=2L$, $s=3L$, $s=4L$) corresponding to proposed spacing.
 - 5.3 At the point on the graph where the Number of Rods line intersects the appropriate spacing line, note the Combined Resistance number at the left.
 - 5.4 Multiply the Combined Resistance number by the resistance of a single ground rod noted in step 2 of this procedure. This is the approximate resistance of the proposed grounding electrode system.

B.4.3.2.1 Example Layout and Graph

Assuming a layout as shown in Figure B-11 with the following characteristics:

- Eight rods (each of 8-ft length) are spaced at 4.9 m (16 ft) points (or “ $2L$ ” in terms of the graph) along a line.
- Soil resistivity measurement (step 1 in “Calculating Grounding Electrode System Resistance With Multiple Ground Rods in a Straight Line” on page B-19) is $4021.5 \Omega\text{-cm}$ for a 3 m (10 ft) test depth.
- Resistance of single ground rod (step 2 in “Calculating Grounding Electrode System Resistance With Multiple Ground Rods in a Straight Line” on page B-19) is 15Ω .

System resistance is calculated as follows:

1. Using Figure B-15: because eight rods are used, “8” line on **Number of Rods** in graph is selected.
2. Because rod spacing is 4.9 m (16 ft) or “ $2L$ ” of rod length, “ $s=2L$ ” line on graph is selected.
3. At the intersection of the “8” line and the “ $s=2L$ ” line, draw a horizontal line to the **Combined Resistance** axis at left. Note the point where the horizontal line crosses the **Combined Resistance** axis (in this case, at approximately “18” (or 18% of single rod resistance).

- Single rod resistance of $15\ \Omega$ is then multiplied by 18% (0.18) to obtain the system's resistance to earth:

$$15\ \Omega \times 0.18 = 2.7\ \Omega$$

In this example, the overall resistance to earth of the proposed grounding electrode system would be $2.7\ \Omega$.

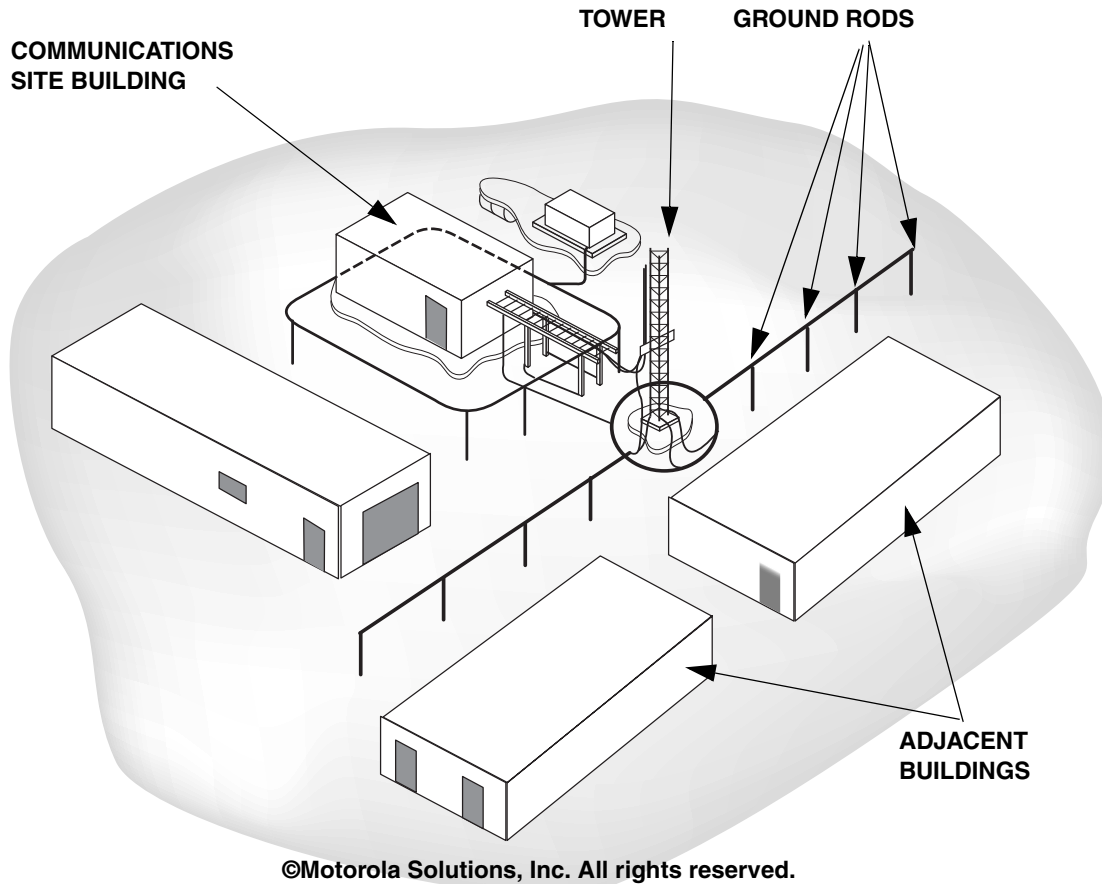

Figure B-11 Example of Multiple Grounding Electrodes in Straight Line

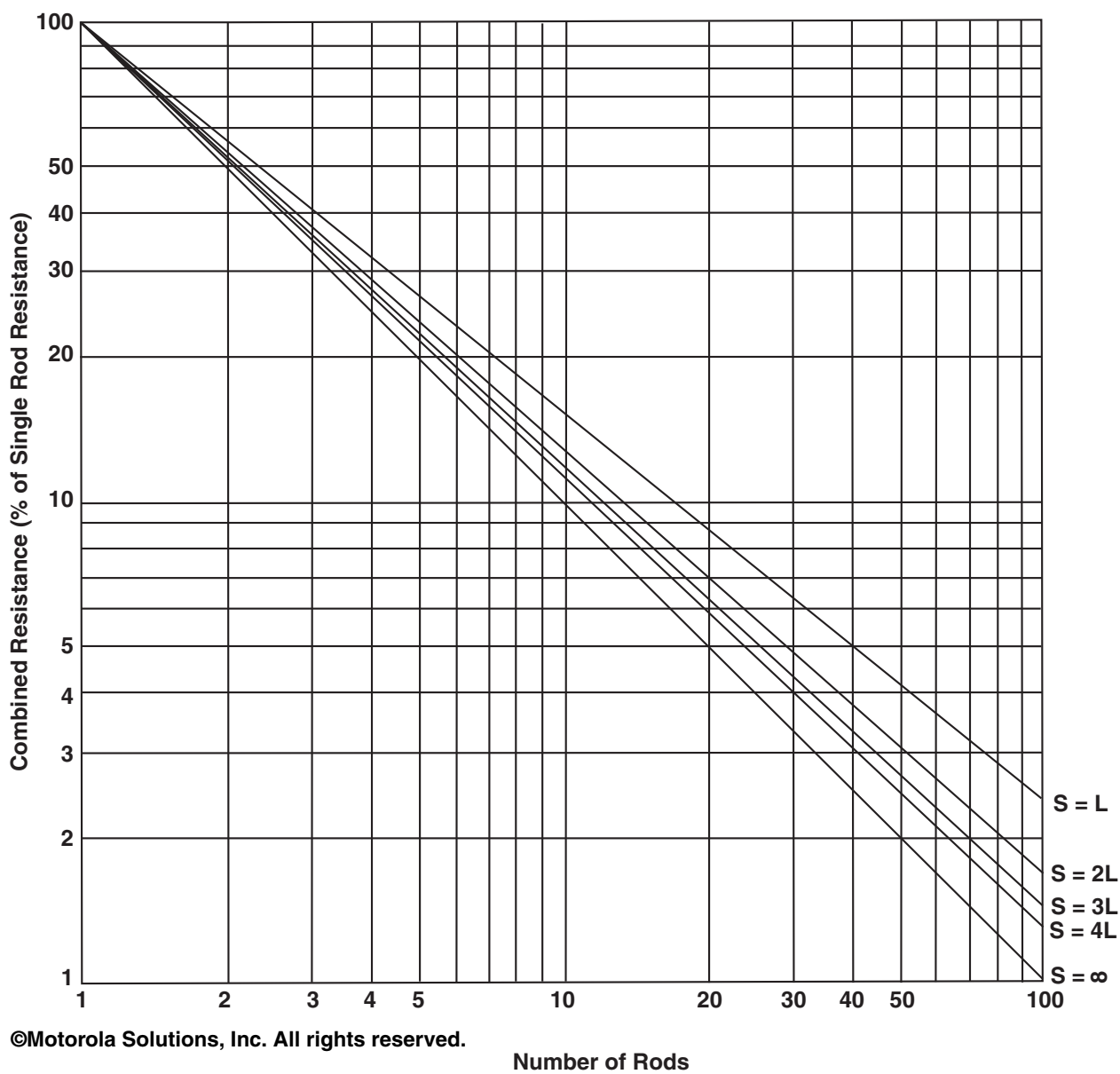

Figure B-12 Combined Resistance Graph (Ground Rods Arranged in Line or Ring)

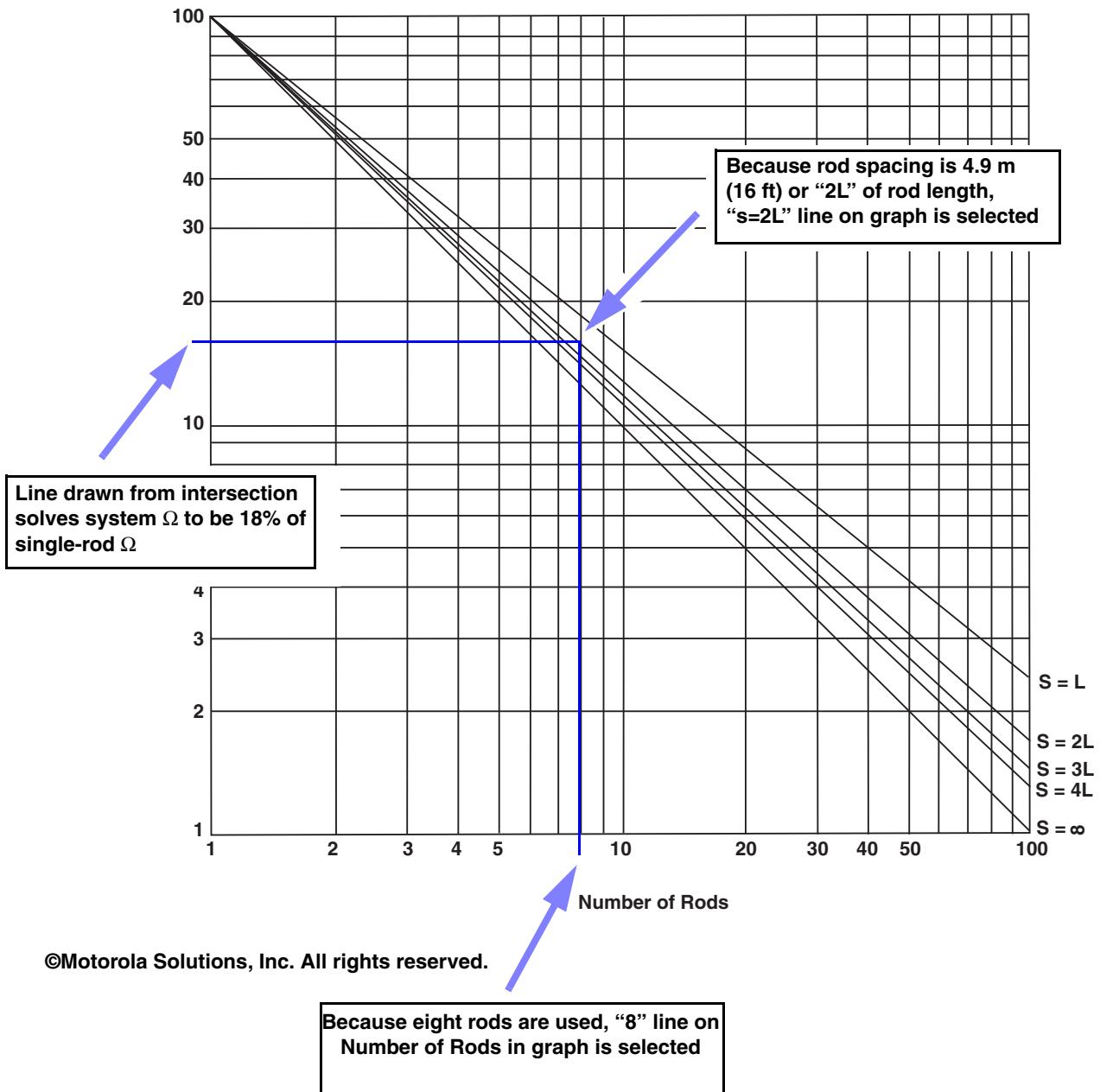

Figure B-13 Example Calculation of Ground Rods Arranged In Straight Line

B.4.3.3 Calculating Grounding Electrode System Resistance With Multiple Ground Rods in Ring Configuration

For a grounding (earthing) electrode system with multiple parallel ground rods installed in a ring configuration (as shown in Figure B-14), the system resistance is calculated in the same manner as ground rods placed in a straight line.

When planning a ring configuration layout and performing calculations, note the following:

- All rods in the system **shall** maintain equal or greater separation from adjacent rods.
- The distance between rods **shall** be figured in a direct path to adjacent rods, not the circumference distance of the ring.

**NOTE**

The stipulations regarding rod spacing specified in “External Building and Tower Ground Ring” on page 4-25 must be observed when planning rod layout.

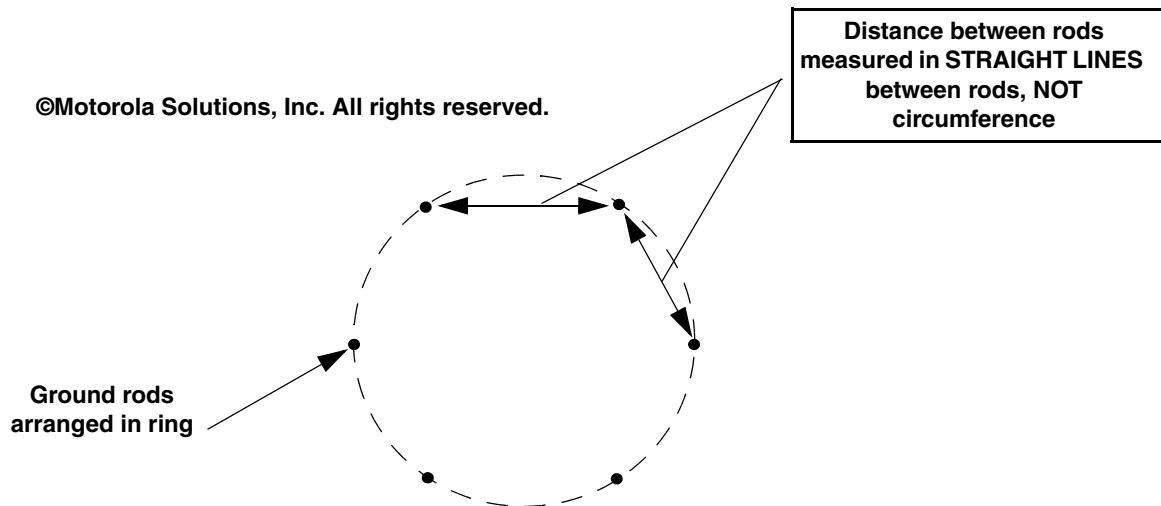

Figure B-14 Ring Configuration Planning and Resistance Measurement Considerations

B.4.3.4 Calculating Grounding Electrode System Resistance With Ground Rods in Grid Configuration

For a grounding (earthing) electrode system consisting of a ground rod grid configuration (as shown in Figure B-15), the system resistance can be calculated as described in the following procedure.

1. Perform soil resistivity test as described in “Soil Resistivity Measurement Procedure” on page B-10.
2. Calculate the resistance of one ground rod as described in “Calculating Single Ground Rod System Resistance” on page B-11. The ρ value used in this step should be the average of all test locations at the site (see Figure B-5). Alternately, the worst-case value can be used for a more conservative calculation. Write down this number.
3. Sketch a proposed layout of the ground rod arrangement using equally spaced rods across the proposed area.

**NOTE**

The stipulations regarding rod spacing as specified in “Ground Rods” on page 4-12 must be observed when planning rod layout.

4. Calculate the area of the proposed grid system in square feet.

**NOTE**

This procedure requires that grid measurements be entered in square feet. If metric measurements have been made, the measurements must be converted to feet. Appendix E, “General Conversions and Formulas”, for conversion formulas.

5. Make a photocopy of Figure B-16.
6. Using the copy of Combined Resistance Graph (Ground Rods Arranged in Grid), calculate the effective resistance of the proposed layout as follows:

- 6.1 Noting the number of rods to be used, locate this number on the **Number of Rods** axis of the graph.
- 6.2 Note the square footage of the proposed rod layout. Locate the curve on the graph most closely corresponding to the proposed square footage.
- 6.3 At the point on the graph where the **Number of Rods** line intersects the appropriate square footage curve, note the **Resistance Ratio** number at the left.
- 6.4 Multiply the **Resistance Ratio** number by the resistance of a single ground rod noted in step 2 of this procedure. This is the approximate resistance of the proposed grounding electrode system.

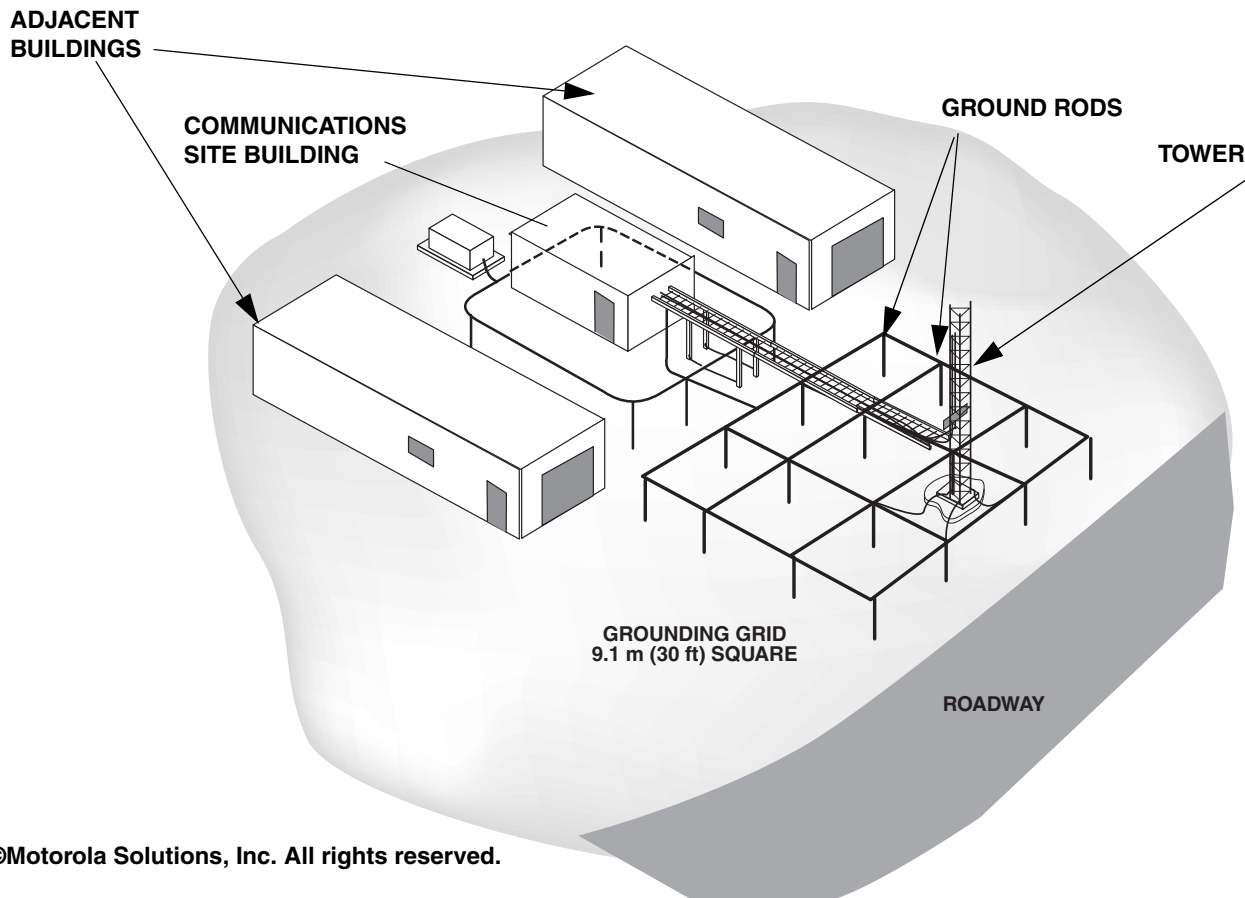

Figure B-15 Example of Multiple Ground Rod Grid Configuration

B.4.3.4.1 Example Layout and Graph

Assuming a layout as shown in Figure B-15 with the following characteristics:

- 16 rods equally spaced across a 30 × 30 ft grid (900 sq. ft).
- Soil resistivity measurement (step 1 in “Calculating Grounding Electrode System Resistance With Ground Rods in Grid Configuration” on page B-23) is 4021.5 Ω -cm.
- Resistance of single rod (step 2 in “Calculating Grounding Electrode System Resistance With Ground Rods in Grid Configuration” on page B-23) is 15 Ω .

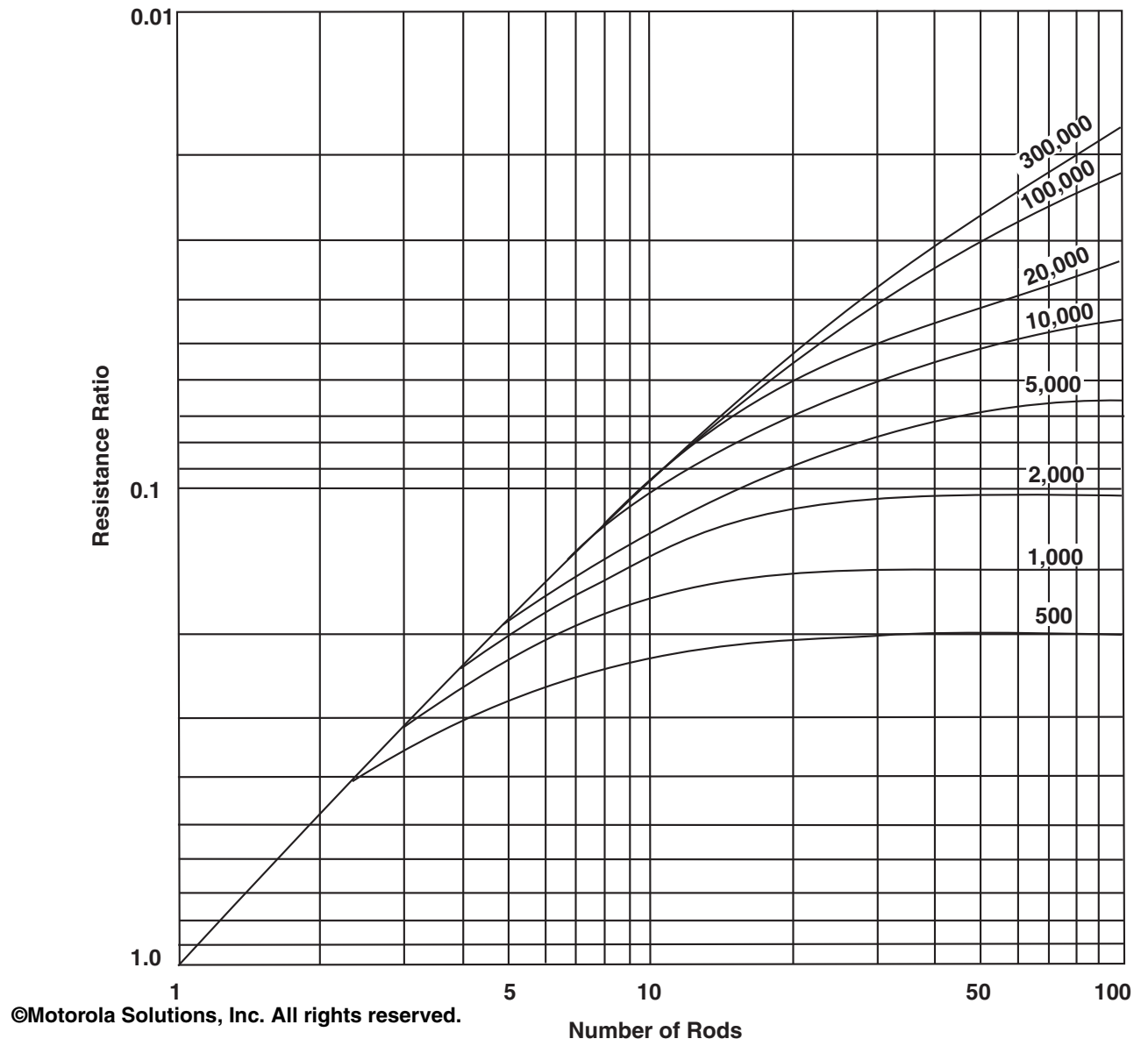

Figure B-16 Combined Resistance Graph (Ground Rods Arranged in Grid)

THIS PAGE INTENTIONALLY LEFT BLANK.

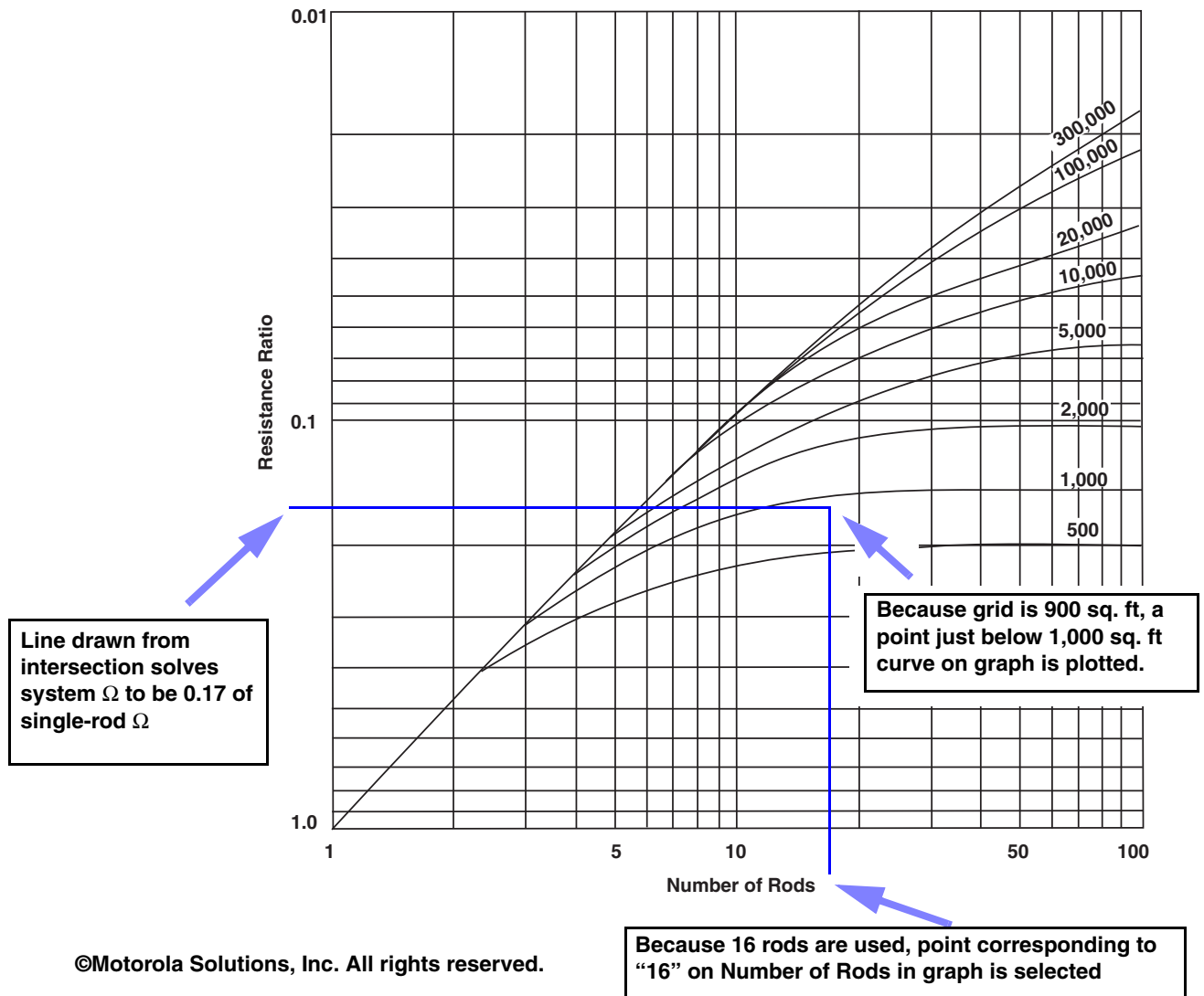

Figure B-17 Example Calculation of Ground Rod Grid Configuration

System resistance is calculated as follows:

1. See Figure B-17. Because 16 rods are used, the point corresponding to "16" on **Number of Rods** in graph is selected. Draw a line vertically from the "16" point on the graph.
2. Because the grid is 900 sq. ft, a point just below the **1,000** sq. ft curve on graph is plotted on the line drawn on the graph.
3. At the point plotted in the previous step, (intersection of "900" sq. ft and "16" rods), draw a horizontal line to the **Resistance Ratio** axis at left. Note the point where the drawn horizontal line crosses **Resistance Ratio** axis (in this case, at approximately ".17").
4. The single ground rod resistance of 15Ω is then multiplied by 0.17 to obtain the resistance to earth of the system:
 $15\Omega \times 0.17 = 2.55 \Omega$

In this example, the overall resistance to earth of the proposed grounding electrode system would be 2.55Ω .

B.4.3.5 Simplified Calculations

IEEE 142-2007 (also known as the IEEE green book™) offers a simplified method to **approximate** the total resistance to earth of a system consisting of 2 to 24 ground rods placed one rod length apart in a line, hollow triangle, circle or square. The resistance to earth of a single ground rod must first be calculated using methods described in this chapter (see “Calculating Single Ground Rod System Resistance” on page B-11). The resistance to earth of the system can then be approximated using the following formula and Table B-7.

$$R_{total} (\Omega) = \frac{\text{resistance of single rod}}{\text{total number of rods}} * \text{multiplication factor (F) from table}$$

Table B-7 MULTIPLICATION FACTORS FOR MULTIPLE GROUND RODS

Number of Rods	Multiplication Factor (F)
2	1.16
3	1.29
4	1.36
8	1.68
12	1.80
16	1.92
20	2.00
24	2.16

Source: IEEE 142-2007, Table 4-6

Example Calculation: Assuming a layout similar to that shown in Figure B-17 with the following characteristics:

- 8 ground rods are spaced 2.4 m (8 ft) apart.
- Resistance of single ground rod is 15Ω.

The grounding electrode system resistance is approximated using the formula and table as follows:

As shown in Table B-7, the multiplication factor for 8 ground rods is 1.68.

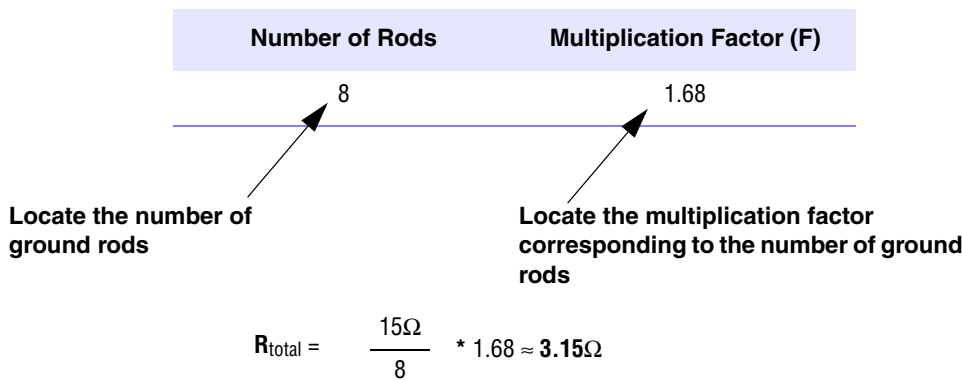

B.4.3.6 Calculating Resistance of Complex Ground Rod Systems

Complex ground rod systems consist of multiple subsystems bonded together to form an overall site ground rod system. Figure B-18 shows a typical complex ground rod system.

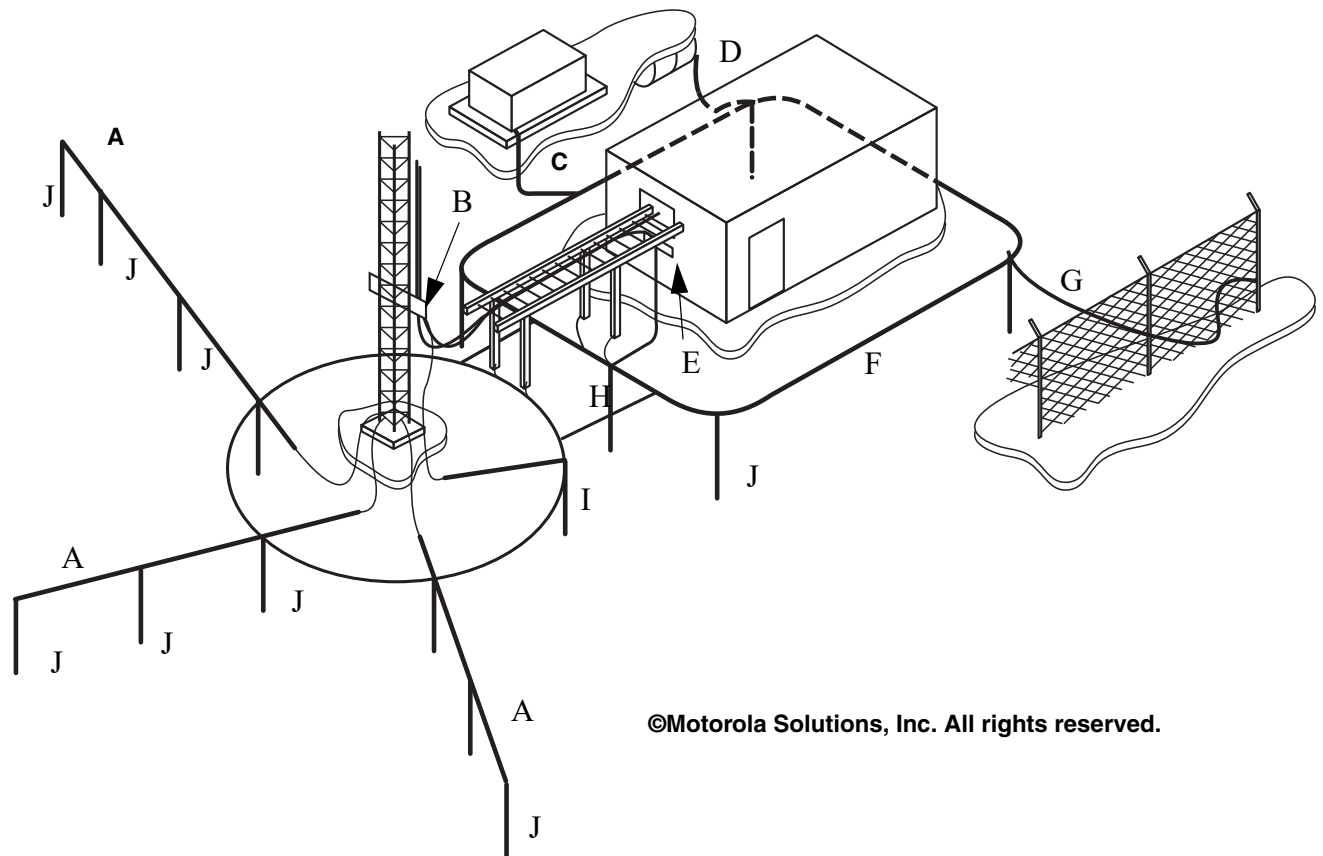

©Motorola Solutions, Inc. All rights reserved.

- A: Grounding Radials
- B: Tower Ground Bus Bar and Down Conductor
- C: Generator Grounding Conductor
- D: Buried Fuel Tank Grounding Conductor
- E: External Ground Bus Bar
- F: Shelter Ground Ring
- G: Fence Grounding Conductor
- H: Ground Ring Bonding Conductors (2 minimum)
- I: Tower Ground Ring
- J: Earthing Electrodes (Ground Rods)

Figure B-18 Typical Complex Grounding Electrode System



NOTE

The following method is an approximation and should be considered accurate to +/- 20%. If greater accuracy is required, Motorola Solutions recommends consultation with an engineering firm.

Resistance of a complex ground rod system can be **approximated** by breaking the system into subsystems. Typically, a ground rod system can be broken down into the following individual subsystems:

- Building ground ring

- Tower ground ring
- Tower radial grounding conductors

For a complex ground rod system consisting of the subsystems described in this section or similar multiple subsystems, the overall system resistance can be approximated as described in the following procedure.



NOTE

Adjacent subsystems should not be laid out closer than the ground rod spacing distance used within a particular subsystem. This is because as subsystems become closer than this distance, the effectiveness of their combined resistance value decreases.

1. Perform soil resistivity test as described in “Soil Resistivity Measurement Procedure” on page B-10.
2. Calculate the resistance of one ground rod as described in “Calculating Single Ground Rod System Resistance” on page B-11. The ρ value used in this step should be the average of all test locations at the site (see Figure B-5). Alternately, the worst-case value can be used for a more conservative calculation. Record this number as it is needed for following calculations.
3. Sketch a proposed layout of the ground rod arrangement using equally spaced rods across the proposed area.



NOTE

The stipulations regarding rod spacing as specified in “Ground Rods” on page 4-12 must be observed when planning rod layout.

4. Calculate the resistance of the building ground ring subsystem as described in “Calculating Grounding Electrode System Resistance With Multiple Ground Rods in Ring Configuration” on page B-22. Write down the result.
5. Calculate the resistance of the tower ground ring subsystem as described in “Calculating Grounding Electrode System Resistance With Multiple Ground Rods in Ring Configuration” on page B-22. Write down the result.
6. Calculate the resistance of the tower radial grounding conductor subsystem as follows:
 - 6.1 Calculate and record the resistance of each **individual** tower radial grounding conductor as described in “Calculating Grounding Electrode System Resistance With Multiple Ground Rods in a Straight Line” on page B-19.



NOTE

If the radial grounding conductor does not contain ground rods, the resistance to earth of the radial grounding conductor can be calculated as follows:

**Buried Horizontal Length
of Wire (straight)
 $D \ll L$**

$$R = \frac{\rho}{\pi L} \left[\ln \left(\frac{(2L)}{(2aD)^{1/2}} \right) - 1 \right]$$

R = resistance of electrode in ohms

ρ = soil resistivity in ohm-meters

L = conductor length in meters

a = conductor radius in meters

d = conductor depth in meters

D \ll L (D is much less than L)

- 6.2** Using the results obtained in the preceding step, calculate the **combined (parallel) resistance of the tower ground radials as follows:**

$$R_{\text{total}} = \frac{1}{\frac{1}{R_{\text{radial1}}} + \frac{1}{R_{\text{radial2}}} + \frac{1}{R_{\text{radial} \dots n}}}$$

**NOTE**

The ground rods associated with the tower ground ring are not included in the calculation of the tower radial grounding conductors.

- 7.** Noting the resistances determined for the subsystems, calculate the combined (parallel) resistance of **all of the subsystems** as follows:
- subsystem 1 (building ground ring subsystem; step 4)
 - subsystem 2 (tower ground ring subsystem; step 5)
 - subsystem 3 (tower ground radial subsystem; step 6)

$$R_{\text{total}} = \frac{1}{\frac{1}{R_{\text{subsystem1}}} + \frac{1}{R_{\text{subsystem2}}} + \frac{1}{R_{\text{subsystem3}}}}$$

**NOTE**

Total resistance does not include incidental influence from site fencing, buried fuel tanks or other objects not included in these calculations. More complex grounding systems or highly accurate results where other objects exist, require the assistance of an appropriate engineering firm.

B.4.3.6.1 Example Calculation of Complex System

Assuming a layout as shown in Figure B-18 with the following characteristics:

- Soil resistivity measurement (step 1 in “Calculating Resistance of Complex Ground Rod Systems” on page B-29) is 4021.5 Ω -cm.
- Building ground ring (step 4 in “Calculating Resistance of Complex Ground Rod Systems” on page B-29) using four rods, each with a resistance of 15 Ω . Building ground ring subsystem calculates to approximately 4.35 Ω .
- Tower ground ring (step 5 in “Calculating Resistance of Complex Ground Rod Systems” on page B-29) using three rods, each with a resistance of 15 Ω . Tower ground ring subsystem calculates to approximately 5.55 Ω .
- Tower radial grounding conductor subsystem (step 6 in “Calculating Resistance of Complex Ground Rod Systems” on page B-29) as shown in Figure B-18. Total resistance of this subsystem is as follows:
 - Radial “A” has three ground rods. Resistance of this radial calculates to approximately 5.55 Ω .
 - Radial “B” has two ground rods. Resistance of this radial calculates to approximately 8.1 Ω .
 - Radial “C” has two ground rods. Resistance of this radial calculates to approximately 8.1 Ω .

Tower ground radial calculates to 2.34 Ω as shown in the following example using the formula provided in step 6:

$$R_{\text{tower radial}} = 2.34 \Omega = \frac{1}{\frac{1}{5.55\Omega} + \frac{1}{8.1\Omega} + \frac{1}{8.1\Omega}}$$

Overall system resistance is calculated as follows:

1. The individual resistances of the three subsystems are noted:
 - **Building ground ring = 4.35 Ω**
 - **Tower ground ring subsystem = 5.55 Ω**
 - **Tower ground radial = 2.34 Ω**
2. The combined (parallel) resistance of all of the subsystems is now calculated as follows:

$$R_{\text{total}} = 1.19 \Omega = \frac{1}{\frac{1}{4.35\Omega} + \frac{1}{5.55\Omega} + \frac{1}{2.34\Omega}}$$

In this example, the calculated effective overall resistance of the proposed system would be **1.19 Ω**

Protecting Against Electrostatic Discharge in Equipment Rooms and Dispatch Centers

C.1 Background Information

Static electricity is defined as an electrical charge that is caused by an imbalance of electrons on the surface of a material. This imbalance of electrons produces an electric field that can influence other objects at a distance. Electrostatic Discharge (ESD) is defined as the transfer of electrical charge between bodies at different electrical potentials.

ESD can severely affect the performance and reliability of electronic equipment. ESD failures may occur at a site and not immediately be detected because voltage levels that can cause component failure are below the perception threshold of the individual. See IEEE 1100-2005, section 6.4.3.3, for more information.

Electrostatic charges are built up on the human body by triboelectric charging. Triboelectric charging takes place when two materials come in contact and are separated and a transfer of positive or negative ions takes place. Just by walking across an unprotected floor when the humidity level is low, a person can create a triboelectric charge buildup in the range of 25,000 volts and up. Cathode-ray tube video terminals can also generate intense electric fields that can transfer high amounts of electrostatic charges on the human body. Normally, discharges from the hand are usually imperceptible below potentials of 3000 volts; for sensitive areas such as the face, the threshold of perception may be 500 volts or lower (ATIS-0600321.2015, section 4).

Electrostatic buildup and discharge in a dispatch room can be very annoying to the operator especially when the high voltage energy discharges through the operator's headset ear piece. The high voltage discharge can not only cause annoyance and pain due to the high voltage heat transfer, it can also cause data and audio signal corruption as well as damage or destroy equipment.

Measures to control ESD **shall** be taken when designing for this environment. Most ESD problems are mitigated through proper bonding and grounding techniques, relative humidity control (between 40% and 55% relative humidity is ideal) and attention to the resistivity of flooring and furniture.

Requirements in the appendix are based on ANSI, ANSI/ESD, ATIS, FAA and IEEE standards. Additional information on ESD control can be found on the Electrostatic Discharge Association website: <http://www.esda.org>.



NOTE

Electrostatic discharge (ESD) is generally the cause for many complaints generated by dispatch center personnel.

C.2 Equipment Handling and Storage

To reduce ESD damage to electronic equipment, wrist straps connected to ground **shall** be worn when handling static sensitive devices (See “Wrist-Straps” on page C-2.). ESD-protected packaging **shall** be available for containing modules and boards removed from equipment. Static-dissipative work surfaces and grounded dissipative (or conductive) floor surfaces should be used in equipment rooms. Storage areas should contain grounded cabinets or grounded permanently static-dissipative shelves. Ground points for wrist straps should be provided at strategic locations near equipment sensitive to electrostatic discharge. See ATIS-0600334.2013, section 12, for more information.

C.3 Measures for Controlling Electrostatic Discharge

Depending on the environment and mobility requirements of personnel, there are several ways to address ESD concerns. The least costly ways are more restrictive to personnel mobility and require more focus on properly established and institutionalized operating procedures, such as wrist-straps. These means will not help to eliminate the occurrence of ESD, but will help to dissipate the electrostatic charge from the person's body and keep it from entering the communications system equipment.

There are many strategies for minimizing ESD events. The following sections provide some options, but are not all-inclusive. As a rule, not all of these techniques will be either necessary or desirable to establish an ESD protected area. The appropriate ESD protection strategy should be based on the particular application and the advantages and disadvantages of each ESD protective method. See ATIS-0600321.2015, section 4, for more information.

C.3.1 Wrist-Straps



IMPORTANT

Personnel servicing electronic equipment shall wear a wrist strap as appropriate to prevent ESD damage to the equipment. ESD Wrist-Straps shall meet the requirements of ANSI/ESD-S20.20-2014 or later.

Personnel can be equipped with ESD-rated wrist-straps. The person connects the wrist-strap to an effectively grounded jack before connecting to the headset jack or touching equipment or grounded objects. The wrist-strap **shall** provide dissipative resistance values and other safety measures as described within ANSI/ESD S1.1-2013 or later and ANSI/ESD S20.20-2014 or later.

C.3.2 Relative Humidity Control



IMPORTANT

Rooms containing network operator positions (dispatch centers) should maintain a relative humidity within the range of 40% to 55%.

Control of the relative humidity can be an effective means for helping control ESD occurrences because higher relative humidity aids in static dissipation and is associated with lowered triboelectric charging. Rooms containing network operator positions (dispatch centers) should maintain a relative humidity within the range of 40% to 55% (ATIS-0600321.2015, section 4.1). Where the humidity drops below 40%, ESD events are more likely to occur. If humidity is kept above 55%, electrolytic corrosion may affect equipment performance, and microbial contamination may occur (ATIS-0600321.2015, section 4.1).

Table C-1 lists typical voltage levels at different relative humidity levels.

Table C-1 EXAMPLES OF STATIC GENERATION TYPICAL VOLTAGE LEVELS

Means of Generation	10-25% RH	65-90% RH
Walking across carpet	35,000 Volts	1,500 Volts
Walking across vinyl tile	12,000 Volts	250 Volts
Worker at bench	6,000 Volts	100 Volts
Poly bag picked up from bench	20,000 Volts	1,200 Volts
Chair with urethane foam	18,000 Volts	1,500 Volts

Electrostatic Discharge Association web site: <http://www.esda.org>

C.3.3 Flooring

Carpeting or floor tiles within an equipment room or dispatch center, including raised flooring, should have a resistance to ground measurement of between 10^6 and 10^{10} ohms when measured using the test method of ANSI/ESD STM7.1-2013 (ATIS 0600321.2015, section 4.2). Existing flooring that does not meet this requirement should be treated with a topical solution such as an anti-static floor wax or spray solution. The effectiveness of anti-static solutions is temporary and varies with floor material and relative humidity. Flooring resistance should be monitored every two weeks minimum to verify conformance to the requirements in this section. See ATIS-0600321.2015, section 4.2, and ANSI/ESD STM7.1-2013 for more information.

Where ESD protective flooring is used, the following should be observed:

- ESD protective flooring **shall** be installed per the manufacturer's recommendations.
- ESD protective flooring and floor coverings **shall** be installed, grounded and tested by trained installers.
- Personnel entering the equipment room or dispatch area should wear ESD dissipative footwear or dissipative foot straps. The footwear should provide dissipative resistance values as described in ANSI/ESD STM97.1-2013 or later.

Where ESD protective flooring is not installed at a dispatch position or equipment room, an ESD protective floor mat **shall** be installed at the work areas. Where ESD protective floor mats are installed, the following should be observed:

- The floor mat should provide dissipative resistance values between 10^6 and 10^{10} ohms when measured using the test method of ANSI/ESD STM7.1-2013 or later.
- The floor mat **shall** be effectively bonded to the common grounding point.
- Personnel should wear ESD dissipative footwear or dissipative foot straps. The footwear should provide dissipative resistance values as described in ANSI/ESD STM97.1-2013 or later.
- Personnel should stand on the floor mat before connecting to the headset jack or touching equipment or grounded objects.

C.3.4 Chairs

Chairs used in dispatch centers should be ESD protective and have a resistance to ground measurement of between 10^6 and 10^{10} ohms when measured using the test method of ANSI/ESD STM12.1-2013 or later. Such chairs operate in conjunction with ESD protective flooring (See “Flooring” on page C-3.). See ATIS-0600321.2015, section 4.3, and ANSI/ESD STM12.1-2013 for additional information.

ESD protective chairs should incorporate a continuous path between all chair elements and the ground point. The ground point of a static dissipative chair should be the static dissipative chain or the conductive casters that provide electrical continuity to the ESD flooring material. See FAA-STD-019e, section 4.1.3.4.3.4, for additional information.



IMPORTANT

Non-dissipative floor mats or chair mats shall not be placed over dissipative flooring material. If floor mats are used, they shall be of a dissipative material with a grounding conductor that is effectively bonded to the common grounding point.

C.3.5 Dispatch Position Desktops



IMPORTANT

To help avoid ESD, the operator must touch the ESD protective desktop or ESD protective mat before connecting to the headset jack or touching equipment or grounded objects.

Work surfaces on the operator position desktops that may be touched by the operator should have a resistance to ground measurement of between 10^6 and 10^{10} ohms when measured using the test method of ANSI/ESD S4.1-2006 or later. If an existing desktop does not meet this requirement, an ESD protective mat can be installed under and around the keyboard and mouse. To be effective, the ESD protective desktop or ESD protective mat must be bonded to the operator position common grounding point. See ATIS-0600321.2015, section 4.4, ANSI/ESD S4.1-2006 and FAA-STD-019e for additional information.

C.3.6 Video Display Terminals



NOTE

Installing liquid crystal display (LCD) or Light Emitting Diode (LED) monitors instead of cathode ray tube (CRT) monitors can reduce ESD at operator positions.

If a CRT monitor is used, installation of an electrostatic shield such as a properly grounded bezel or a conductive anti-glare shield that is properly bonded to the common grounding point will be of some benefit (ATIS-0600321.2015, section 4.6). Another option is installing LCD or LED monitors, which do not generate high electrostatic fields.

C.3.7 Equipment Bonding, Grounding and Surge Protection

All equipment installed in an equipment room and at a network operator (dispatch) position **shall** be properly bonded and grounded according to the requirements of Chapter 5, “Internal Bonding and Grounding (Earthing)”.

Surge suppression should be provided in accordance with “Surge Protection Considerations for Dispatch Centers and Operator Positions,” on page 7-50.



IMPORTANT

In addition to ESD protective measures, all equipment in an equipment room and at a network operator position shall be properly grounded, bonded, and protected from surges using Surge Protective Devices (SPD).

C.4 ESD Control Program

After preventive measures have been implemented to help eliminate or dissipate electrostatic charges, an effective ESD control program should be implemented to maintain the environment. For additional information on how to establish an effective ESD control program, see Part Two - Principles of ESD Control at the Electrostatic Discharge Association web site (<https://www.esda.org/about-esd/esd-fundamentals/part-2-principles-of-esd-control>).

Grounding (Earthing) Electrode System Testing/ Verification and Bonding Continuity Testing/Verification

This appendix provides procedures for performing resistance testing of the site grounding electrode system. The resistance of a grounding electrode system **shall** be measured after its installation and before it is bonded to the power utility neutral wire or any other utility, such as the telephone ground or metallic pipes. See Chapter 4, “External Grounding (Earthing) and Bonding”, for grounding electrode system resistance requirements.

Periodic testing should be performed on the site annually when the site grounding electrode system can be safely disconnected from the power utility neutral wire (if using the fall-of-potential test). Suggested best practice is to perform the test at three-month intervals for the first year and every 21 months thereafter (MIL-HDBK-419A).



IMPORTANT

The procedures in this appendix are not intended for sites with multiple utility power services or other complex power applications. Consultation with an engineering firm is recommended in these applications.



NOTE

Throughout this appendix the terms *grounding* and *earthing* are used interchangeably.

D.1 Safety

Procedures in this appendix **shall not** be performed by untrained or unqualified personnel, nor are any procedures herein intended to replace proper training. It is required that personnel attempting to measure the resistance of a grounding (earthing) electrode system receive prior formal training on the subject and on its associated safety hazards. All applicable laws, rules and codes regulating the work on electrical systems **shall** be complied with at all times. See IEEE 81-2012, section 5.1, for more information.

All safety warnings and cautions listed within this appendix and within the ground resistance tester documentation **shall** be followed at all times.



WARNING

It should be strongly impressed on all test personnel that a lethal potential can exist between the station ground and a remote ground if a power-system fault involving the station ground occurs while ground tests are being made. Because one of the objectives of tests on a station-ground system is to establish the location of remote earth for both current and potential electrodes, the leads to these electrodes must be treated as though a possible potential could exist between test leads and any point on the station ground grid. Under no circumstances should the two hands or other parts of the body be allowed to complete the circuit between points of possible high-potential difference. (IEEE 81-1983, section 5.1.)



WARNING

To help protect against shock hazard, insulated electrician's footwear and gloves SHALL be worn while performing grounding electrode system testing.

**WARNING**

Check for current on the grounding electrode conductor before disconnecting. Never disconnect the ground of a live circuit. Disconnecting the ground of a live circuit could cause severe injury or death.

**WARNING**

Only qualified personnel SHALL open an electrical panel to attempt a ground resistance measurement. Lethal voltages may be present. A lethal voltage can exist between the grounding electrode under test and a remote ground.

**WARNING**

Appropriate fall restraint and fall arrest techniques SHALL be observed when climbing or when using any kind of personnel lift. Applicable national and local codes SHALL be followed.

**WARNING**

To help prevent eye injury, always wear eye protection when striking ground rods with a hammer.

**IMPORTANT**

Refer to NFPA 70E[®], Standard for Electrical Safety in the Workplace[®] for additional electrical safety information.

D.2 Overview

Grounding (earthing) electrode system testing can be performed using one of the following methods (see IEEE 81-2012 for more information):

D.2.1 Fall-of-Potential Testing

This method is the most widely accepted. Performing the test may require access to areas that extend beyond the site property lines. When testing a grounding electrode system consisting of a multi-bonded complex grounding electrode system (commonly used at communication sites), the distance required for testing is directly related to the effective diagonal distance of the buried grounding electrode system (including grounded fence posts).

D.2.2 Clamp-on Ground Resistance Test (also known as Clamp-on Ohmmeter Test)

This method should be used when access to necessary space needed for the fall-of-potential test is not available. The clamp-on ohmmeter test can only be performed after the AC utility has been connected to the site and various feed conductors are accessible.

D.2.3 Combined Soil Resistivity Testing with Clamp-on Ohmmeter Testing

This method should only be used in special cases where fall-of-potential testing and clamp-on ohmmeter testing cannot directly provide a suitable evaluation. The data obtained from soil resistivity testing and clamp-on ohmmeter testing is then used by an engineering firm to make determinations regarding the grounding electrode system resistance.

D.3 Prerequisites for Testing

This section provides the testing prerequisites for the tests listed in “Overview” on page D-2. Some guidance is also given for situations when the testing prerequisites cannot be met.

D.3.1 Fall-of-Potential Test

Fall-of-Potential testing is possible only if the following conditions can be met:

- Sufficient land area must be available to perform a fall-of-potential test. The outer reference probe may likely need to be inserted into soil that is beyond the site property line (see “Testing Area Requirements” on page D-7). Testing using a clamp-on ohmmeter may be an option where sufficient land area is not available.
- The grounding electrode system must be able to be isolated from the power utility grounded conductor (may be a neutral wire) and other utility grounds, such as telephone or cable television. Isolation must include removing any secondary paths to the utility grounds.



NOTE

A suggested best practice in new construction is to test the grounding electrode system resistance before it is bonded to the power utility ground, other utility grounds and other items that may provide a secondary path to the utilities.

D.3.2 Clamp-on Ground Resistance Test

Clamp-on ohmmeter testing is possible only if the following conditions can be met:

- The site must be supplied with commercial power. Sites supplied only by a generator or other non-commercial power source may not be suitable for clamp-on ohmmeter testing.
- A grounded conductor (may be a neutral wire) must be present and part of an extensive power utility grounding system.
- The grounding electrode system must be connected to the power utility grounded conductor (may be a neutral wire).
- For a single grounding electrode system, the grounding electrode conductor must be accessible to the clamp-on ohmmeter at a point between the grounding electrode and any other connection (such as the telephone service provider ground or a metallic pipe).
- For sites using a multi-bonded complex grounding electrode system (commonly used at communications sites), a point on the neutral wire before its first bond to the site must be available for using the clamp-on ohmmeter.



NOTE

The clamp-on ohmmeter test can be performed at a site if the power utility is not yet connected, as long as the power utility ground is available nearby. A temporary test jumper may be clamped to the site grounding electrode system and to the nearby utility ground. The clamp-on ohmmeter is then placed around this test jumper for a grounding electrode system resistance reading. All other utility grounds must be disconnected from the site. See Figure D-20 for an example. The resistance of the test jumper should be tested and factored out of the grounding electrode system resistance reading. The resistance can be measured with an ohmmeter or by clipping the ends of the test jumper together and placing the clamp-on ohmmeter around the jumper. See Figure D-12 for an example.

D.3.3 Combined Soil Resistivity and Clamp-on Ohmmeter Test

Combined soil resistivity and clamp-on ohmmeter testing is possible only if the following conditions can be met:

- The system must be such that gathering of individual grounding electrode system component values with a clamp-on ohmmeter can be available for use by an engineering firm. For example, large ground test wells are installed over several ground rods to allow clamping around the ground rod with a clamp-on ohmmeter (this would provide the resistance of each individual ground rod). See “Site AC Power Disconnect Requirements” on page D-21 for power utility connection requirements.

- A soil resistivity test has been performed at the site and the results are available for use by an engineering firm. See Appendix B, “Soil Resistivity Measurements”, for soil resistivity information.
- A grounding electrode system as-built diagram is available for use by an engineering firm.

D.3.4 Testing Prerequisites Not Met

If any of the conditions described in “Prerequisites for Testing” on page D-3 and its subsections cannot be met, a supplemental grounding electrode system can be installed. This supplemental grounding electrode system should be designed and installed to allow easy disconnecting for testing purposes. Alternately, ground test wells can be strategically installed in the supplemental system to allow for easy clamp-on ohmmeter testing of the system or portions of the system. See Figure D-1 and Figure D-16 for examples.

- Figure D-1 shows easy testing of the individual radial grounding conductors.
- Figure D-16 shows convenient testing of the entire supplemental grounding electrode system.

The scenario described in the preceding paragraph is not common in new construction, but may be encountered when installing equipment at an existing site when proper documentation of the grounding electrode system is not available. Installation of a supplemental grounding electrode system may be the only method available to verify the resistance to earth.

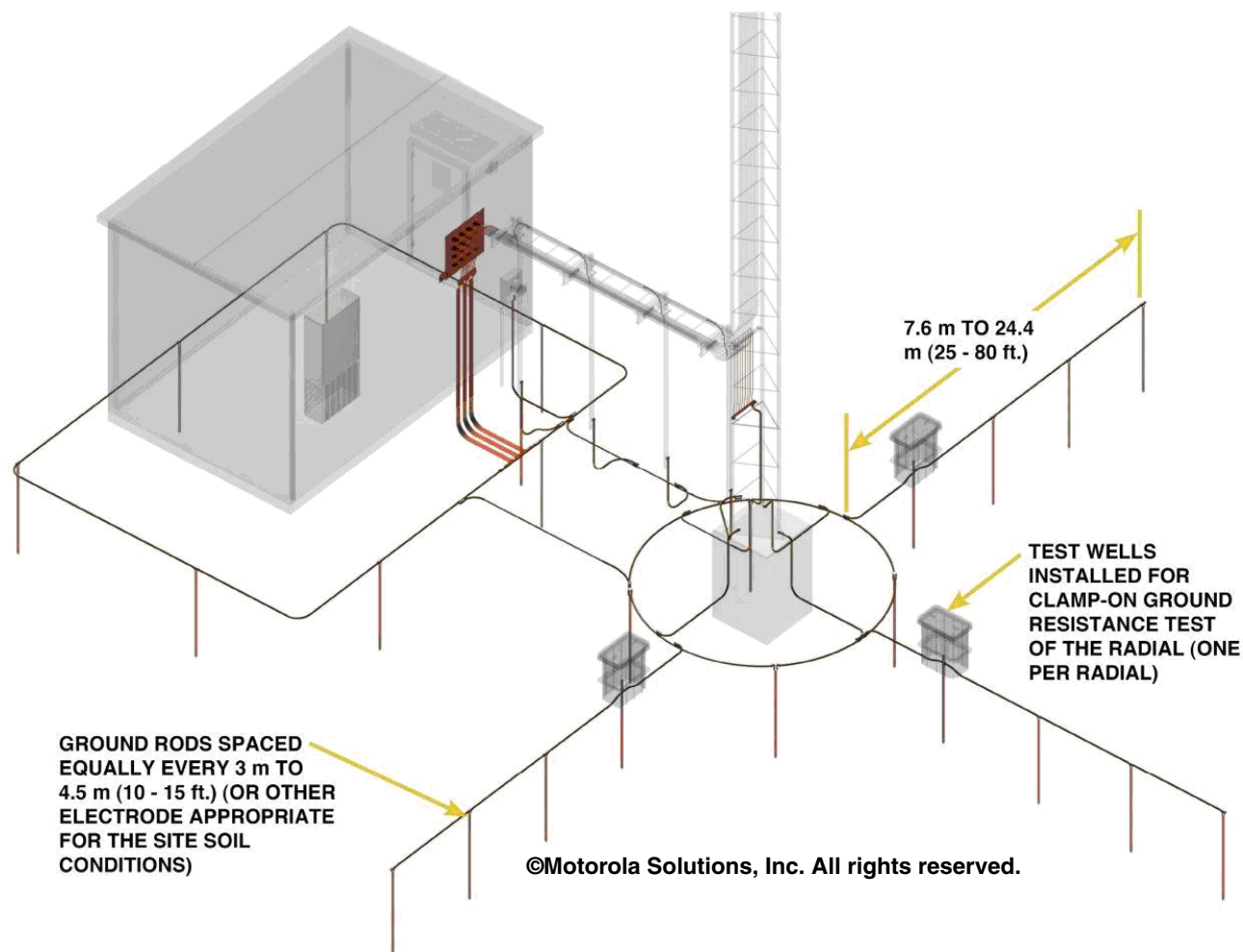

Figure D-1 Supplemental Grounding Electrode System With Test Location

D.4 Fall-of-Potential Testing Procedure

D.4.1 Test Description and Theory

The fall-of-potential test is the most widely accepted and recommended test method. This procedure is documented in IEEE 81, BS 7430:2011, MIL-HDBK-419A, NFPA 780-2017 and NWSM 30-4106, which should be referred to for more details.

The principle of grounding electrode system resistance measurements is shown in Figure D-2. R is the grounding electrode or grounding electrode system under test, Y is the auxiliary potential electrode, and Z is an auxiliary current probe. A known current is passed through the grounding electrode system under test (R) and returns through the auxiliary current probe (Z). The voltage (V) between R and Y is measured by the ground resistance tester. With the known test current (I) and measured voltage (V) between R and Y, the ground resistance tester applies Ohm's law ($R=V/I$) to display the resistance.



IMPORTANT

The grounding electrode system under test must be isolated from the utility power ground and all other utility grounds (such as the telephone service provider ground). In order to achieve an accurate measurement, all test current from the meter must flow through the grounding electrode system under test. If the grounding electrode system under test is not isolated, the test current divides among all available paths, resulting in an inaccurate measurement of the grounding electrode system under test.

In the fall-of-potential test, two test rods are driven into the soil. These rods are placed in a straight line from the grounding electrode system to be tested (referred to here as connection X). One of the test rods, referred to as rod Z, is placed at a known distance from the X connection. The other test rod (referred to as rod Y) is placed at various distances between the X connection and rod Z. If a known current is applied between the X connecting point and rod Z, a voltage (E) difference exists between the X connection and rod Y. The ground resistance tester measures the voltage drop between the X connection and rod Y and converts the measurement to a resistance reading using Ohm's Law ($R= E/I$). In this manner, the resistance at any point between the X connection and rod Z can be measured. The multiple readings obtained during this test are entered and plotted as data points on a graph. From the graph, the resistance of the grounding electrode system can be determined.

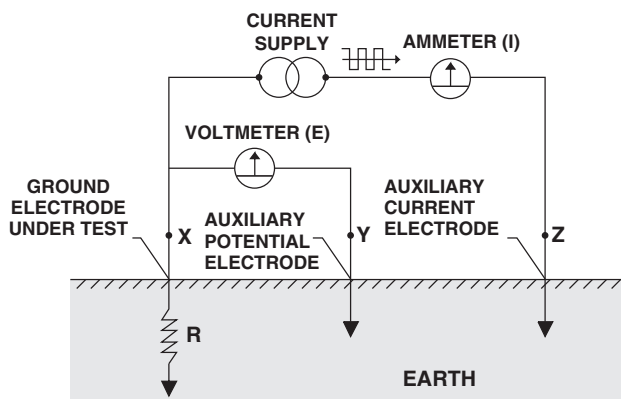

©Motorola Solutions, Inc. All rights reserved.

Figure D-2 Principles of Grounding Electrode Resistance Measurement



NOTE

Voltage may be abbreviated as E or V.

**NOTE**

The tester terminals may be labeled differently on different tester models. See the tester's User Manual for details. For example, the following naming conventions are typical:

X, Y and Z on a three-terminal tester (the naming convention used throughout this appendix)

X/Xv, Y and Z on a four-terminal tester

X, P and C on a three-terminal tester

C1/P1, P2 and C2 on a four-terminal tester

E/ES, S and H on a four-terminal tester

In order to obtain accurate ground resistance measurements, the Z probe must be placed far enough away from the grounding electrode system under test (see "Testing Area Requirements" on page D-7). The effective resistance areas (spheres of influence) of the grounding electrode system under test (X), the test probe (Y) and the auxiliary current probe (Z) must not overlap (see "Ground Rod Resistance Characteristics and Sphere of Influence" on page 4-9 for additional information). Figure D-3 is an example of the effective resistance areas improperly overlapping. Overlapping effective resistance areas will result in an inaccurate ground resistance reading.

**NOTE**

When multiple Y location readings are plotted on a graph, it can be determined whether or not proper probe spacing was maintained. Proper probe spacing results in a plateau on the graph (see "Interpreting Test Results" on page D-15).

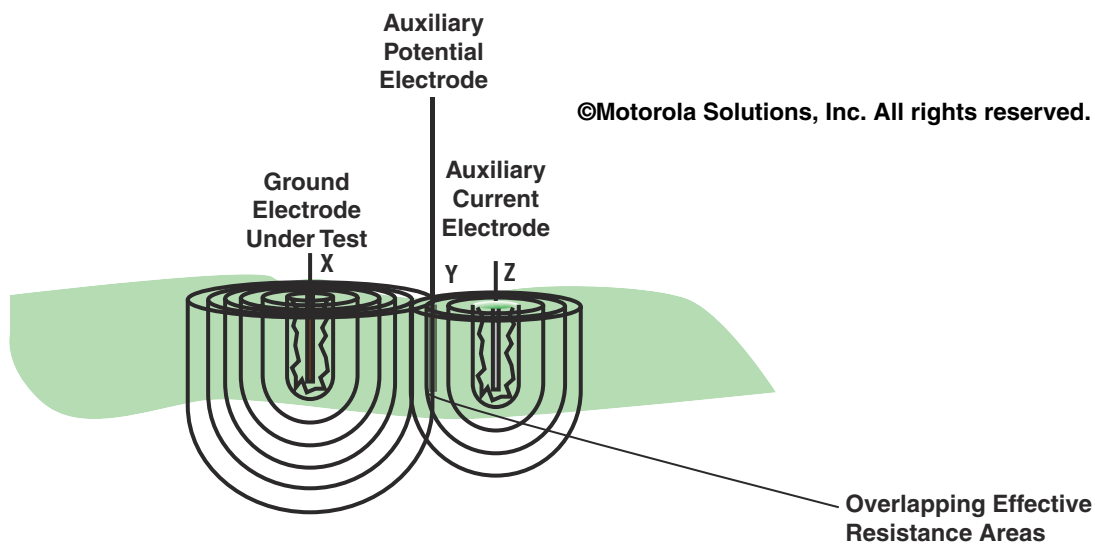

Figure D-3 Effective Resistance Areas Improperly Overlapping

D.4.2 Required Test Equipment and Supplies

The following test equipment and supplies are required for performing the fall-of-potential test:

- Fall-of-potential ground resistance tester (with supplied Operator Manual)
- Meter test leads and probes
- Small sledgehammer
- Tape measure
- Safety glasses

- Insulated electrician's footwear and gloves
- Several photocopies of Table D-6, which are needed to record and keep track of several measurements across the site.
- Several photocopies of Figure D-21, which are needed to graph the resistance profile across the measurement area.

D.4.3 Preparation for Testing

D.4.3.1 Testing Area Requirements

This fall-of-potential test requires a reference test rod (outer reference test probe Z) which is placed outside the field of influence of the grounding (earthing) electrode system. In many cases, this required location is outside of the site property line. Figure D-4 shows a typical site layout and its required spacing distance between the site and the reference test rod. The following stipulations apply:

- For a **single grounding electrode system**, the distance of the reference probe **shall** be minimally 5 times, to preferably 10 times, the depth of the grounding electrode from the surface of the soil to the bottom of the buried electrode. For fall-of-potential testing distance measurements, the planar center of a single grounding electrode system is the electrode connecting point above ground.
- For a **multi-bonded complex grounding electrode system**, the distance of the reference probe **shall** be minimally 5 times, to preferably, 10 times the diagonal distance of the grounding electrode system. For fall-of-potential testing distance measurements, the planar center of a multi-bonded complex grounding electrode system is the extreme edge of the system in the direction of where the test probes are inserted. See Table D-1 for a resistance accuracy versus reference probe spacing.



IMPORTANT

If radial grounding conductors are used in the grounding electrode system (as in Figure D-1), they must be considered when measuring the diagonal distance. This diagonal distance is then used for determining the required placement of the Z probe.

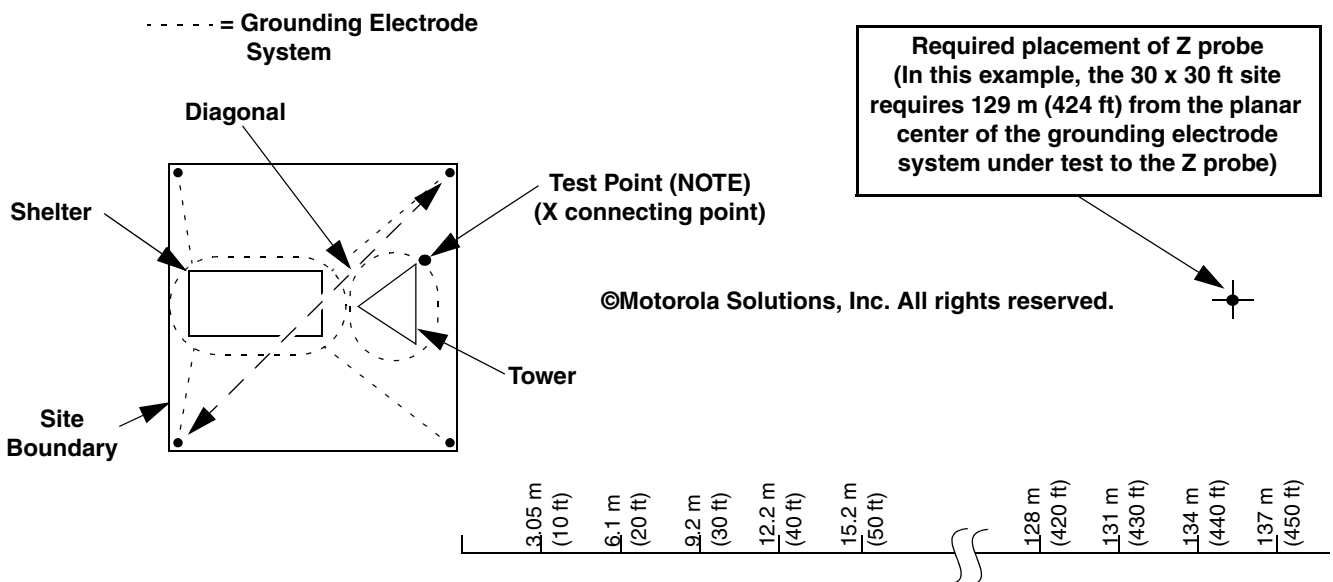

Figure D-4 Outer Reference Electrode (Z Probe) Placement for a Typical Site



NOTE

Connection point of meter X clip is typically to a point on the outer edge of the grounding electrode system, such as a fence post grounding conductor or tower leg grounding conductor.

Table D-1 RESISTANCE ACCURACY VS. PROBE C SPACING

Accuracy	Probe Spacing
90%	5 x diagonal under test
95%	10 x diagonal under test
98%	25 x diagonal under test
99%	50 x diagonal under test
Source: MIL-HDBK-419A	

**NOTE**

Any required permissions **shall** be obtained for accessing and placing a test probe on adjacent property before testing is attempted.

Use Table D-2 or Table D-3 to obtain the value for 10-times spacing distance between the site and the outer reference test probe (Z). Table D-2 provides values in feet, and Table D-3 provides values in meters. For the minimum 5 times distance, divide the resulting numbers by 2.

Table D-2 REQUIRED Z-PROBE SPACING FOR SITE LENGTHS AND WIDTHS (IN FEET)

Site Width (ft)	Site Length (ft)									
	10	20	30	40	50	60	70	80	90	100
10	141	224	316	412	510	608	707	806	906	1005
20	224	283	361	447	539	632	728	825	922	1020
30	316	361	424	500	583	671	762	854	949	1044
40	412	447	500	566	640	721	806	894	985	1077
50	510	539	583	640	707	781	860	943	1030	1118
60	608	632	671	721	781	849	922	1000	1082	1166
70	707	728	762	806	860	922	990	1063	1140	1221
80	806	825	854	894	943	1000	1063	1131	1204	1281
90	906	922	949	985	1030	1082	1140	1204	1273	1345
100	1005	1020	1044	1077	1118	1166	1221	1281	1345	1414
110	1105	1118	1140	1170	1208	1253	1304	1360	1421	1487
120	1204	1217	1237	1265	1300	1342	1389	1442	1500	1562
130	1304	1315	1334	1360	1393	1432	1476	1526	1581	1640
140	1404	1414	1432	1456	1487	1523	1565	1612	1664	1720

Table D-2 REQUIRED Z-PROBE SPACING FOR SITE LENGTHS AND WIDTHS (IN FEET) (CONTINUED)

Site Width (ft)	Site Length (ft)									
	10	20	30	40	50	60	70	80	90	100
150	1503	1513	1530	1552	1581	1616	1655	1700	1749	1803
160	1603	1612	1628	1649	1676	1709	1746	1789	1836	1887
170	1703	1712	1726	1746	1772	1803	1838	1879	1924	1972
180	1803	1811	1825	1844	1868	1897	1931	1970	2012	2059
190	1903	1910	1924	1942	1965	1992	2025	2062	2102	2147
200	2002	2010	2022	2040	2062	2088	2119	2154	2193	2236

Table D-3 REQUIRED Z-PROBE SPACING FOR SITE LENGTHS AND WIDTHS (IN METERS)

Site Width (m)	Site Length (m)									
	3	6	9	12	15	18	21	24	27	30
3	43	68.3	96.3	125.6	155.4	185.3	215.5	245.7	276.1	306.3
6	68.3	86.3	110	136.2	164.3	192.6	221.9	251.5	281	310.9
9	96.3	110	129.2	152.4	177.7	204.5	232.3	260.3	289.3	318.2
12	125.6	136.2	152.4	172.5	195	219.8	245.7	272.5	300.2	328.3
15	155.4	164.3	177.7	195	215.5	238	262.1	287.4	313.9	340.8
18	185.3	192.6	204.5	219.8	238	258.8	281	304.8	329.8	355.4
21	215.5	221.9	232.3	245.7	262.1	281	301.8	324	347.5	372.2
24	245.7	251.5	260.3	272.5	287.4	304.8	324	344.8	367	390.4
27	276.2	281	289.3	300.2	313.9	329.8	347.5	367	388	410
30	306.3	310.9	318.2	328.3	340.8	355.4	372.2	390.4	410	431
33	336.8	340.8	347.5	356.6	368.2	381.9	397.5	414.5	433.1	453.2
37	367	371	377	385.6	396.2	409	423.4	439.5	457.2	476
40	397.5	400.8	406.6	414.5	424.6	436.5	449.9	465.1	482	499.9
43	428	431	436.5	443.8	453.2	464.2	447	491.3	507.2	524.3
46	458.1	461.2	466.3	473	482	493	504.4	518.2	533.1	549.6
49	488.6	491.3	496.2	502.6	510.8	520.9	532.2	545.3	559.6	575.2

Table D-3 REQUIRED Z-PROBE SPACING FOR SITE LENGTHS AND WIDTHS (IN METERS) (CONTINUED)

Site Width (m)	Site Length (m)									
	3	6	9	12	15	18	21	24	27	30
52	519	521.8	526	532.2	540.1	549.6	560.2	572.7	586.4	601
54.9	549.6	552	556.3	562	569.4	578.2	588.6	600.5	613.3	627.6
57.9	580	582.2	586.4	591.9	598.9	607.2	617.2	628.5	640.7	654.4
60.1	610.2	612.6	616.3	621.8	628.5	636.4	645.9	656.5	668.4	681.5

D.4.3.2 Test Direction and Other Test Tips

The test direction (determined by the location of the Z probe) must be carefully chosen so it does not parallel any buried metallic objects. Buried metallic objects could impact the measurements because they could provide an alternate path for the test current. Such buried objects could include, but are not limited to, water pipes, conduits, cables, tanks, concrete footings (due to the rebar), and so on.

The test direction should also be selected so that it is not in close proximity to overhead high-voltage lines and does not parallel the overhead high-voltage lines. The overhead power lines could induce noise into the meter, creating an invalid measurement. If the test must be taken in close proximity to the overhead high-voltage lines, ensure the test direction and test leads are perpendicular to the overhead lines. This should reduce any induced noise. Further noise induction can be reduced by twisting the test leads together (see the meter's User Manual for more information).

To ensure good contact with the earth, compact the soil directly around the auxiliary test electrodes to remove air gaps formed when inserting the rod. If the meter displays any errors and/or has difficulty obtaining a stable measurement, there may be too much auxiliary probe contact resistance. An effective way of decreasing the auxiliary probe contact resistance is to pour water (or sports drink) around the auxiliary rod, as illustrated in Figure D-5. The addition of moisture is insignificant; it helps to achieve a better electrical connection and does not influence the overall results. Do not pour water around an electrode under test.



IMPORTANT

Do not pour water around a grounding electrode or grounding electrode system under test. Doing so artificially enhances the measurement, resulting in an inaccurate reading. Water shall only be added to an auxiliary test probe.



NOTE

Contact the meter manufacturer or engineering firm for testing recommendations on asphalt or other hard surfaces.

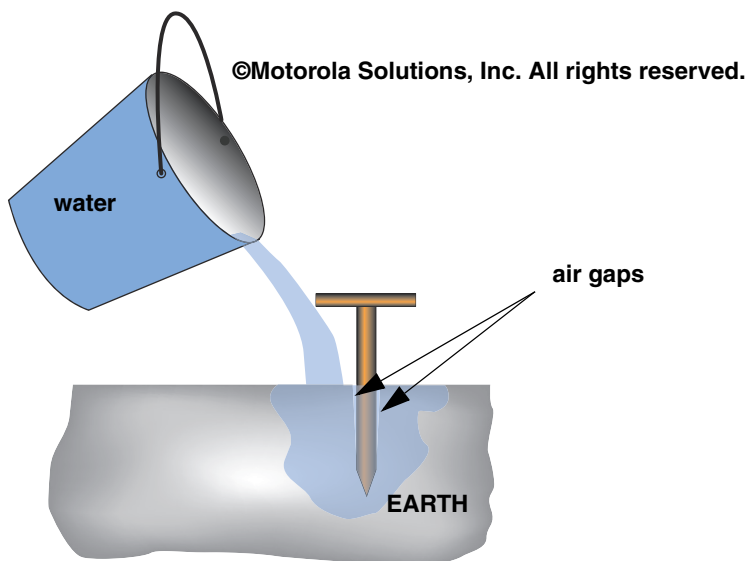

Figure D-5 Improving Electrical Contact by Adding Water to the Soil

D.4.3.3 Site AC Power And Other Utility Disconnect Requirements

The fall-of-potential test requires disconnection of the site grounding (earthing) electrode system from the power utility grounded conductor (may be a neutral wire) and any other ground (such as telephone service provider ground). Isolating the site grounding electrode system from the power utility ground (and other utility grounds) is required in order to allow testing that is limited only to the site grounding electrode system. Attempting to perform measurements while the site remains connected to the power utility ground (or other utility ground) artificially enhances the grounding electrode system reading, resulting in measurement error.



NOTE

A suggested best practice in new construction is to test the grounding electrode system resistance before it is bonded to the power utility ground, other utility grounds and other items that may provide a secondary path to the utilities.

At an existing site supplied by commercial AC power, the following steps must be taken prior to performing a fall-of-potential test:

1. Coordinate the test with the customer and/or site owner and all other affected parties.
2. Arrange for the site to have the commercial power utility AC power turned off. If the site must remain operational while testing is performed, the site should be switched to a back-up power source if it is available.



WARNING

Check for current on the grounding electrode conductor before disconnecting. Never disconnect the ground of a live circuit. Disconnecting the ground of a live circuit could cause severe injury or death.

3. Have the site grounding electrode system isolated from the power utility grounded conductor by a qualified electrician, ensuring that it has no secondary path to the site via a conduit or other connection (this can be verified with the use of a multi-meter). The only way to achieve this (especially at a communications site with a multi-bonded complex grounding electrode system) may be having the power utility grounded conductor (may be a neutral wire) disconnected from the site.

4. Remove any other grounding electrode connection that may influence the measurement of the on-site grounding electrode system, such as the telephone service provider ground and metallic water/gas pipes.

D.4.3.4 Fall-of-Potential Test Procedure

Figure D-6 shows typical ground resistance tester connections and test probe orientations.

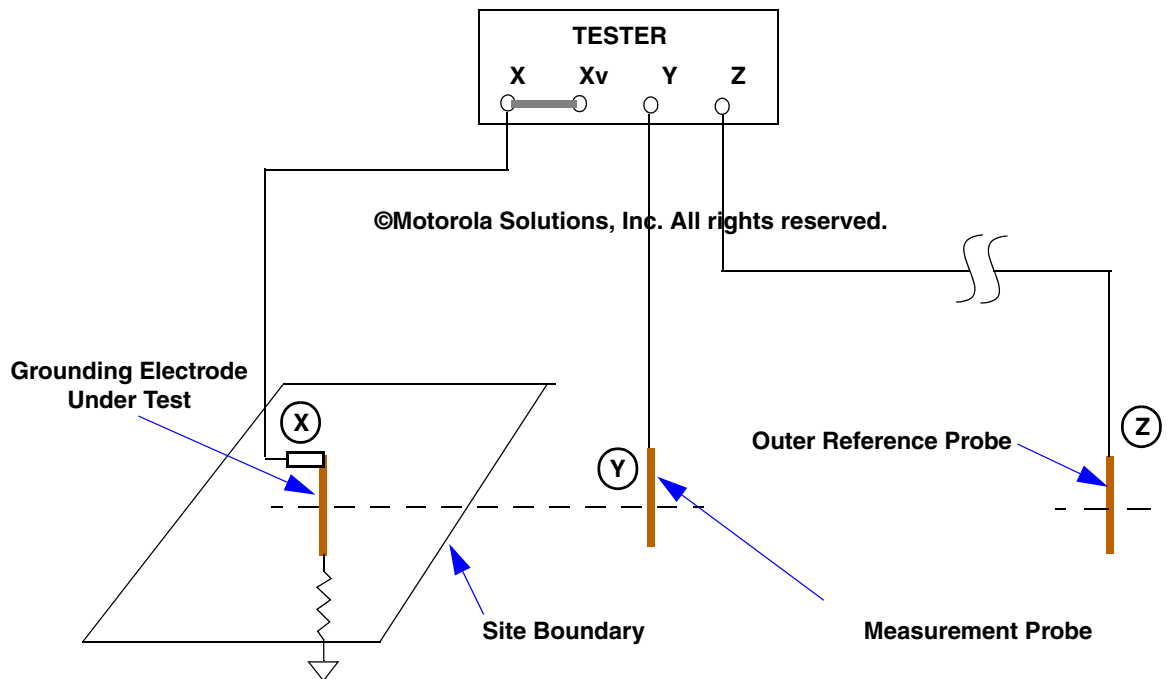

Figure D-6 Typical Ground Resistance Tester Connection



WARNING

Follow ground resistance tester manufacturer's warning and caution information when using tester. Follow furnished instructions when inserting and removing test rods into soil. Make certain this procedure is fully understood before proceeding with test.

Perform the fall-of-potential test as follows:

1. Isolate the grounding electrode system as described in “Site AC Power And Other Utility Disconnect Requirements” on page D-11.
2. On Ground Resistance Tester, connect test leads to the **X**, **Y** and **Z** terminals.
3. Short the **X** and **Xv** connections on the Ground Resistance Tester, if applicable.
4. Connect the **X** lead to the grounding electrode system under test. This is typically via a test clip connection to an external ground bus bar or grounding conductor.
5. Connect the **Y** lead to the measurement (**Y**) probe.
6. Determine the required placement of outer reference probe (**Z**) according to paragraph “Testing Area Requirements” on page D-7.

7. Place the outer reference probe (**Z**) into the soil at the determined location. Connect the outer reference probe (**Z**) to meter terminal **Z**.
8. Note the distance of the outer reference probe (**Z**) from the grounding electrode system (this distance will be used in determining subsequent measurements). On the photocopy of the Fall-of-Potential Test Worksheet (on page D-30), write this distance in the “99%” space.
9. Place the measurement probe (**Y**) in the soil starting close to the area of the grounding electrode system under test. This location must be outside the confines of the grounding electrode system and metallic fence (if present). Take a measurement.
10. On the photocopy of the Fall-of-Potential Test Worksheet, write the reading in the “1%” row of the worksheet.
11. Place the measurement probe (**Y**) at 5% of the distance between the grounding electrode system '**X**' connection and the outer reference probe (**Z**). Take a measurement.

Example: Assuming a “99%” distance of 131 m (430 ft), **Y** probe would be placed at 6.55 m (21.5 ft) for “5%” measurement location.

**IMPORTANT**

Placement of the measurement probe (Y) must be along a straight path between the grounding electrode system 'X' connection and the outer reference probe (Z).

12. On the photocopy of the Fall-of-Potential Test Worksheet, write down the reading in the appropriate row of the worksheet.
13. Place the measurement probe (**Y**) at 10% of the distance between the grounding electrode system '**X**' connection and the outer reference probe (**Z**). Take a measurement.

Example: Assuming a “99%” distance of 131 m (430 ft), **Y** probe would be placed at 13.1 m (43 ft) for “10%” measurement location.

14. Write down the reading in the appropriate row of the photocopy of the Fall-of-Potential Test Worksheet.
15. Repeat steps 13 and 14 for all remaining test locations on the worksheet.
16. On the photocopy of Fall-of-Potential Test Graph Form, plot a graph of the measured resistances for all points listed on the worksheet. The measurements can also be plotted using the [Fall-of-Potential Graph Tool](#) provided with this manual.
17. Proceed to “Interpreting Test Results” on page D-15.

If sufficient access area exists, the entire procedure should be repeated in different directions facing away from the center of the grounding electrode system. Repeating the procedure is recommended in case metal pipes or similar conductive objects are buried within the test area. The presence of metal pipes or similar conductive objects may result in an inaccurate reading.

©Motorola Solutions, Inc. All rights reserved.

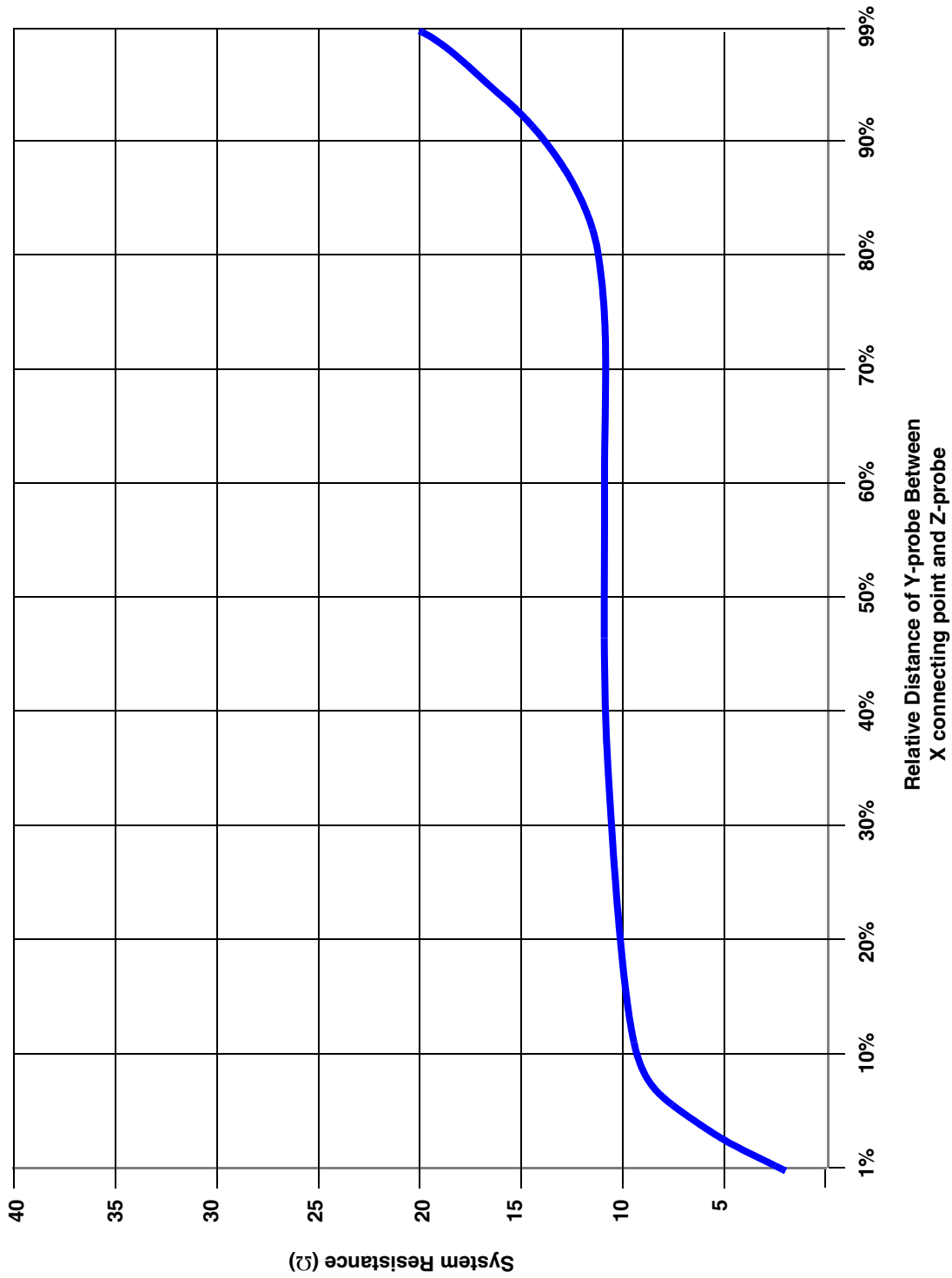

Figure D-7 Fall-of-Potential Test Graph Example

Table D-4 SAMPLE FALL-OF-POTENTIAL TEST DATA

Distance from Grounding Electrode System Grid		Test Data
Percentage	ft (m)	Ohms (Ω)
1%	0	2.5 Ω
5%	21.5 ft (6.55 m)	7 Ω
10%	43 ft (13.1 m)	9.5 Ω
20%	86 ft (16.2 m)	11.3 Ω
30%	129 ft (39.3 m)	11.4 Ω
40%	172 ft (52.4 m)	11.4 Ω
50%	215 ft (65.5 m)	11.5 Ω
60%	258 ft (78.6 m)	11.5 Ω
70%	301 ft (91.7 m)	11.6 Ω
80%	344 ft (104.8 m)	11.9 Ω
90%	387 ft (117.9 m)	13.7 Ω
99%	430 ft (131 m)	20 Ω

D.4.3.5 Interpreting Test Results

This section provides information on interpreting fall-of-potential grounding electrode system resistance tests. In order for the resistance of a grounding electrode system to be properly determined using the fall-of-potential method, multiple Y probe measurements must be taken and plotted on a graph as described in “Fall-of-Potential Test Procedure” on page D-12. The measurements can also be plotted using the [Fall-of-Potential Graph Tool](#) provided with this manual.

Using Figure D-8, assess the test results as follows:

- Valid Test: At approximately 62% of the total distance (“99%” distance), a plateau or “flat spot” should be noticeable in the plot, as shown in the top example of Figure D-8. The resistance at this plateau is the validated resistance of the system under test.
- Invalid Test Graph (insufficient distance of Z-probe): If there is no plateau on the plot, shown in the middle example of Figure D-8, the test is considered invalid because the Z probe is not far enough from the X probe.
- Invalid Test Graph (erroneous connection to neutral): If there appears to be a plateau on the plot, but the curve has very little change until the point nearest the remote current probe as shown in the bottom example of Figure D-8, the test is considered invalid because an erroneous connection of the grounding electrode system to a power utility neutral or other utility ground, remains.
- Figures D-9, D-10 and D-11 show additional fall-of-potential graphs as related to the effective resistance area (sphere of influence) of the grounding electrode system.



IMPORTANT

For a fall-of-potential test to be valid, multiple Y probe measurements must be taken and plotted on a graph, and the graph must contain a plateau. Graphs that do not contain a plateau are not valid, therefore, the test must be also be considered invalid.

VALID TEST GRAPH

At approximately 62% of the total distance, a plateau or “flat spot” should be noticeable in the plot. The resistance at this plateau is the resistance of the system under test.

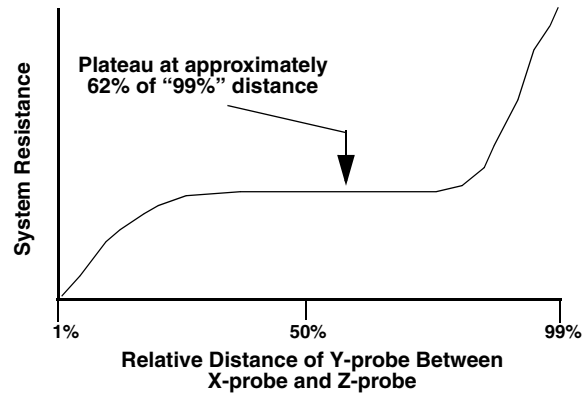

INVALID TEST GRAPH (Z-Probe Spacing)

The Z probe is not placed far enough from the grounding electrode system.

Reposition Z-probe farther away from X connecting point and repeat test.

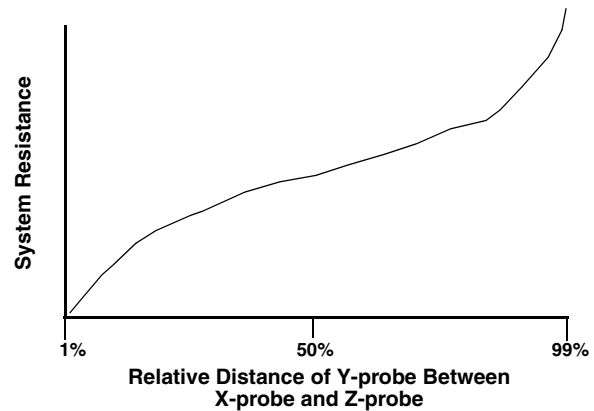

©Motorola Solutions, Inc. All rights reserved.

INVALID TEST GRAPH (Connection to neutral)

Due to a connection that still exists to the power utility neutral conductor or other utility, the resulting curve has very little change until the point nearest the remote current probe. No valid plateau exists.

Disconnect the utility ground connection and repeat test.

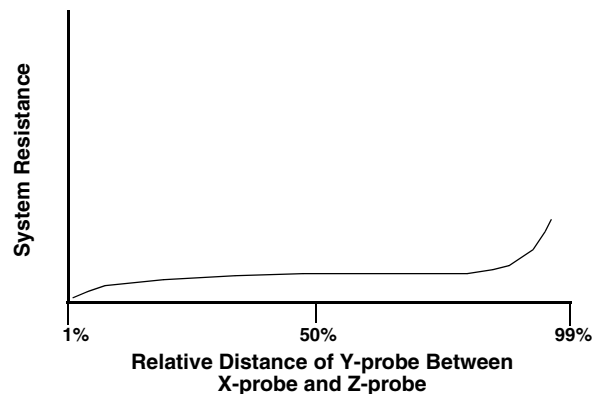

Figure D-8 Typical Fall-of-Potential Test Graph Results

Figure D-9 shows a valid fall-of-potential graph. The graph contains a sharp rise at the beginning, a plateau in the middle and a sharp rise near the end. A plateau is obtained because the Z probe is spaced far enough away that the effective resistance areas (spheres of influence) of the grounding electrode system and the Z probe do not overlap.

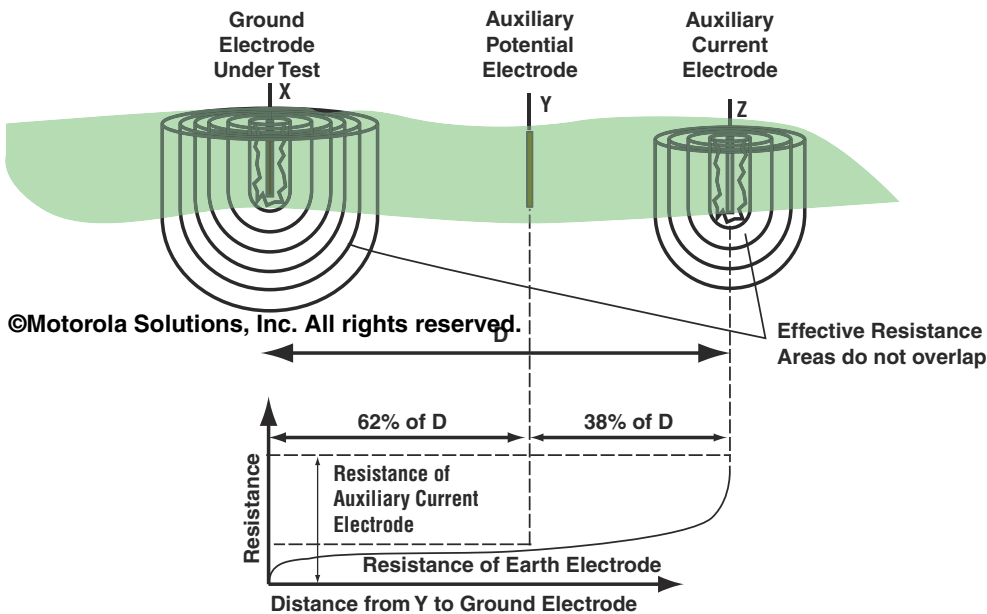

Figure D-9 Valid Test Graph: No Overlap of Effective Resistance Areas of X, Y and Z

Figure D-10 shows an invalid fall-of-potential graph. The graph does not contain a plateau in the middle. A plateau was not obtained because the Z probe was not spaced far enough away from the grounding electrode system. The improper Z probe spacing caused the effective resistance areas (spheres of influence) of the grounding electrode system and the Z probe to overlap.

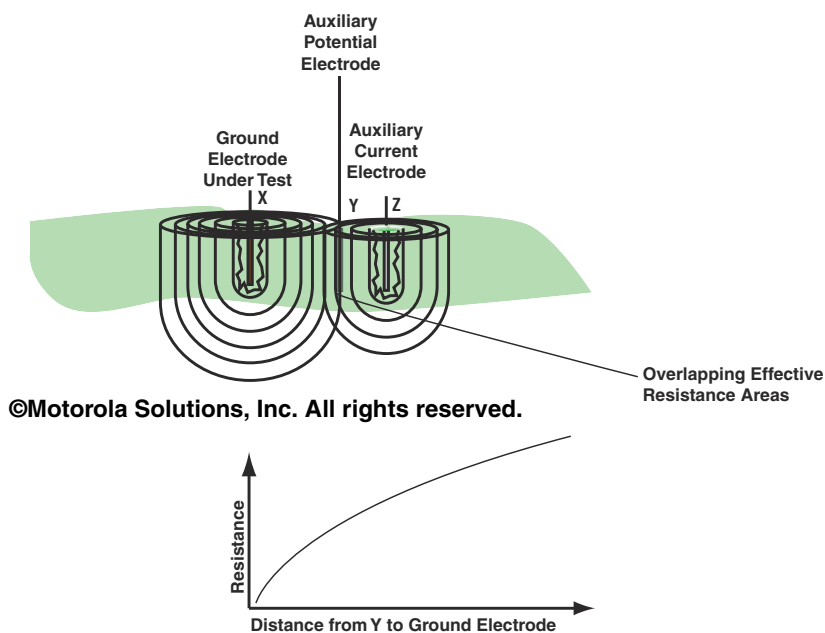

Figure D-10 Invalid Test Graph: Effective Resistance Areas of X, Y and Z Overlap

Figure D-11 shows an invalid fall-of-potential graph. The graph has very little change until the point nearest the remote current probe (Z). This type of graph response is indicative of a test performed while the AC power utility or other utility ground is still connected to the grounding electrode system. Note that the grounding electrode system effective resistance area (sphere of influence) is totally contained within the AC utility sphere of influence.

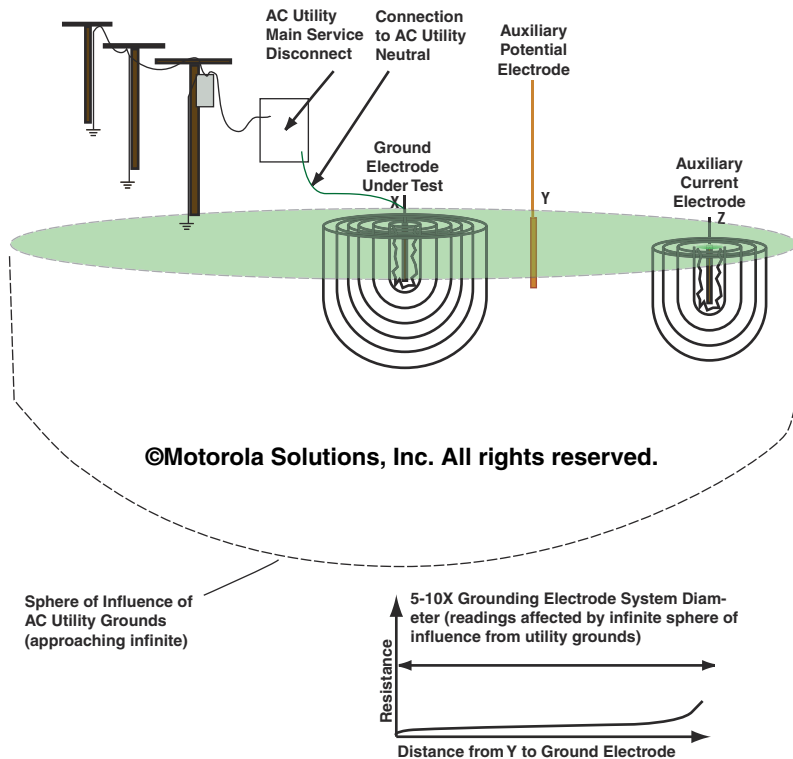

Figure D-11 Invalid Test Graph: The Grounding Electrode System is Not Isolated From the AC Utility Ground

D.5 Clamp-On Ohmmeter Testing Procedure

The clamp-on ground resistance test (also known as clamp-on ohmmeter test) is an effective alternative to the fall-of-potential test (see BS 7430:2011, Clause 10.3.6, and IEEE 81-2012, section 8.2.2.5). The clamp-on ohmmeter test can be used in many applications that might not be practicable for the fall-of-potential test. Such applications may include testing at sites with limited available land for the fall-of-potential test or testing live sites where isolation of the AC utility power ground may not be practicable.

The clamp-on ohmmeter test can be performed on both a single grounding (earthing) electrode and a multi-bonded complex grounding electrode system (such as at a communications site). However, the test can only be accurately performed on sites supplied by commercial power.

For a single grounding electrode system, the test is considered very reliable and can be easy to perform. However, for a multi-bonded complex grounding electrode system (such as at a communications site), the test is more difficult to perform and may result in an error reading due to parallel paths. The test procedure in this section has provisions to help avoid such errors.



IMPORTANT

If the electrical service provided by the power utility does not contain a grounded conductor that is bonded to the extensive power utility grounding system, the clamp-on ohmmeter will not give an accurate reading. In these cases, this is because there is no effective low resistance return path (zero ohm reference) for the meter.

**NOTE**

In addition to testing the resistance of a grounding electrode system, the clamp-on ohmmeter is also an effective tool for verifying bonding connections. See “Clamp-on Ohmmeter Bonding Continuity Testing” on page D-28.

D.5.1 Test Description

The clamp-on ohmmeter works on the basis of inducing a low-frequency test current (usually between 1kHz and 3.4 kHz), from a known voltage source, into a conductive *loop*. The magnitude of the test current is a function of the loop resistance. It is up to the operator of the meter to determine and understand what loop is being tested. The placement of the meter typically determines the loop being tested.

Figure D-12 illustrates some conductive loops and meter readings based on meter location.

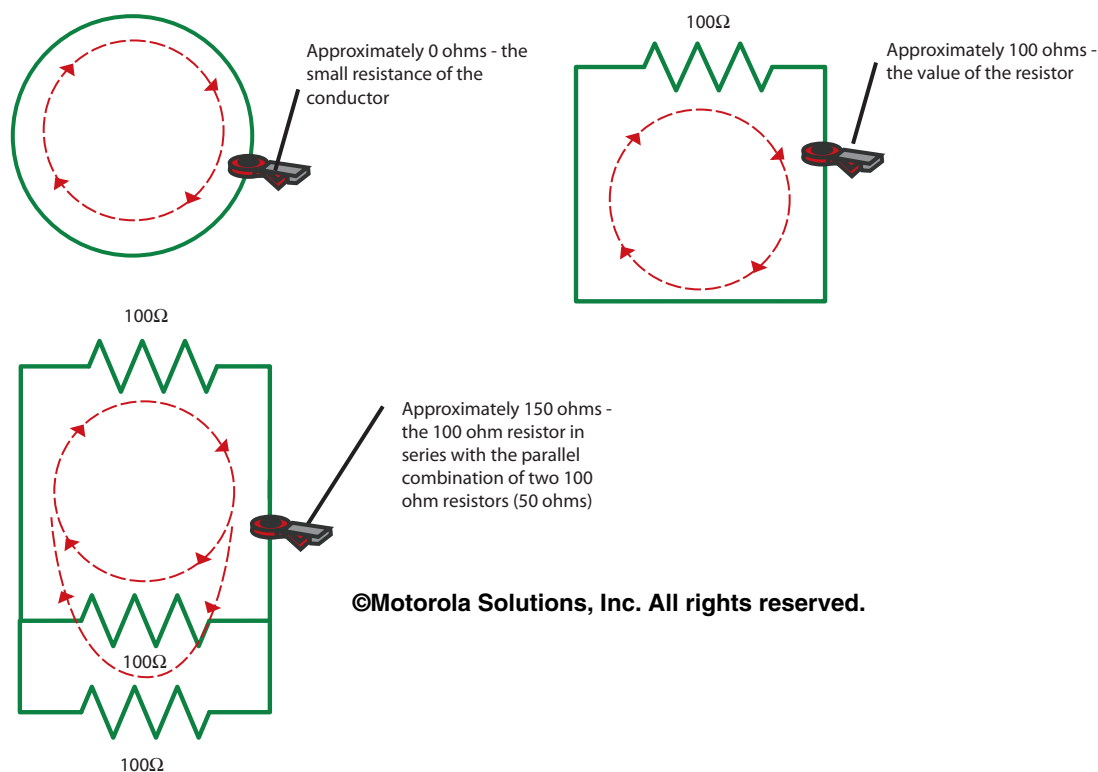

Figure D-12 Clamp-On Ohmmeter Reading Fundamentals

In the case of testing the resistance of a grounding electrode system, the following form the loop:

- The grounding electrode system
- The earth
- The power utility’s extensive ground system
- The power utility grounded conductor (may be a neutral)

In summary, the loop in this case consists of the grounding electrode system under test, which is in series with the parallel combination of all the grounding electrodes that are part of the utility (this includes the ground rods from every house, commercial building, utility transformers and any other grounds that are part of the utility power grid). The total effective resistance of the parallel utility grounds is extremely low, therefore, its value has almost no impact on the loop resistance.

The test current (I) flows from the grounding electrode system through the earth and returns to the grounding electrode system (and the meter) via the power utility grounding system and multi-grounded neutral wire. The meter then measures this current and converts the measurement to a resistance reading using the known voltage (E) and Ohm's Law ($R = E/I$). The meter displays a resistance of the grounding electrode system in ohms. Because the power utility grounding system is so extensive (near zero ohms), it has very little effect on the reading.

Figure D-13 provides a schematic representation of how the clamp-on ohmmeter measures the resistance of a grounding electrode system.

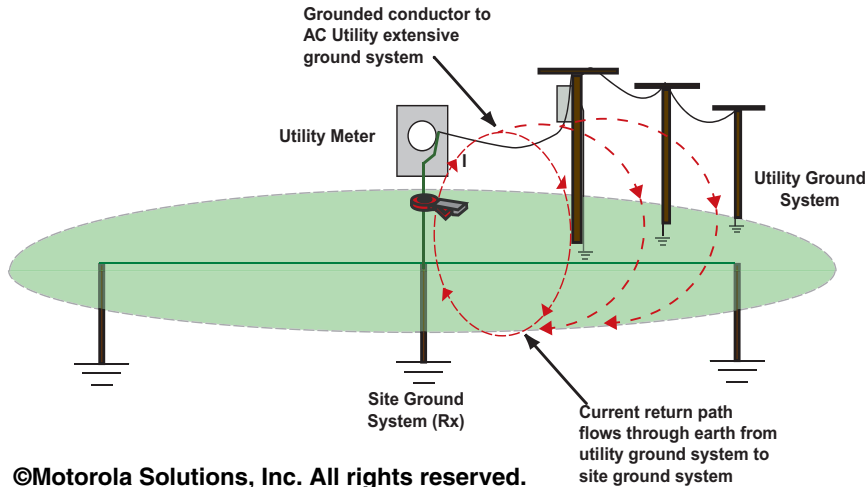

©Motorola Solutions, Inc. All rights reserved.

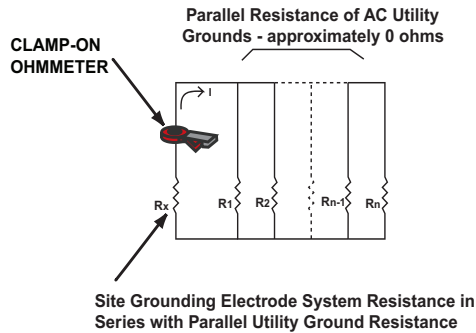
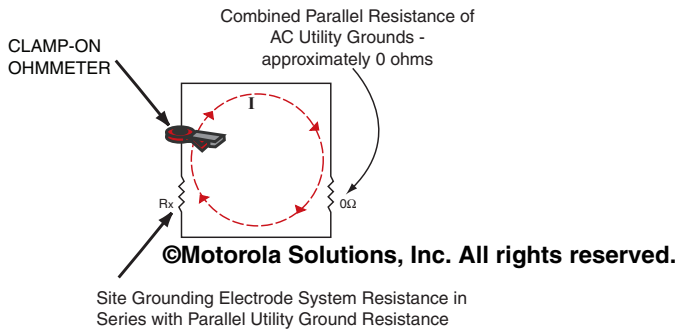

Figure D-13 Clamp-On Ground Resistance Measurement of Site Grounding Electrode System

Figure D-14 illustrates how the combined near-zero resistance of the many utility grounds provides the return path for the clamp-on ohmmeter measuring the resistance of a grounding electrode system.



©Motorola Solutions, Inc. All rights reserved.

Figure D-14 Clamp-On Ground Resistance Measurement of Site Grounding Electrode System

D.5.2 Required Test Equipment and Supplies

The following test equipment and supplies are required to perform a clamp-on ground resistance test:

- Clamp-on Ground Resistance Tester (clamp-on ohmmeter)
- Insulated electrician's footwear and gloves
- Test jumpers for temporary connections
- A photocopy of Table D-7. This will be needed to record measurements.

D.5.3 Preparations for Testing

D.5.3.1 Site AC Power Disconnect Requirements

This test **does not** require disconnection of the site grounding (earthing) electrode system from the power utility grounded conductor (may be a neutral wire). The power utility grounded conductor is required in order for the meter to display a valid reading. However, for a multi-bonded complex grounding electrode system it may be necessary to de-energize the site from commercial power if significant unbalanced current flow is present on the grounded conductor. Unbalanced current flow may create noise on the meter, resulting in the inability of the meter to display an accurate reading. The noise condition is typically indicated by the clamp-on ohmmeter.



NOTE

A backup generator may be used during the clamp-on ohmmeter test if the communications site requires power.



NOTE

The clamp-on ohmmeter test can be performed at a site if the power utility is not yet connected, as long as the power utility ground is available nearby. A temporary test jumper may be clamped to the site grounding electrode system and to the nearby utility ground. The clamp-on ohmmeter is then placed around this test jumper for a grounding electrode system resistance reading. All other utility grounds must be disconnected from the site. See Figure D-20 for an example. The resistance of the test jumper should be tested and factored out of the grounding electrode system resistance reading. The resistance can be measured with an ohmmeter or by clipping the ends of the test jumper together and placing the clamp-on ohmmeter around the jumper. See Figure D-12 for an example.

For a site supplied by commercial AC power that contains a neutral wire which is part of an extensive power utility grounding system and the site contains a multi-bonded complex grounding electrode system, the following steps must be taken first:

1. Coordinate the test with the customer and/or site owner and all other affected parties.
2. Arrange for the site AC power to be turned off and the site switched to a back-up power source if it is available. Any current on the neutral wire (even if less than 3 – 5 amps) can result in a false reading. It is therefore recommended that the commercial power be turned off in order to eliminate any currents on the neutral wire that can affect the meter's ability to give an accurate reading.
3. It may be necessary to remove other utility ground connections (such as telephone), depending on their location. This is typically required for a multi-bonded complex grounding electrode system.

D.5.3.2 Clamp-On Ohmmeter Test Procedures

Depending on whether the site uses a single grounding (earthing) electrode system or multi-bonded complex grounding electrode system, proceed to “Single Grounding (Earthing) Electrode System Testing (or Equivalent),” on page D-22 or “Multi-Bonded Complex Grounding (Earthing) Electrode System Testing,” on page D-24 as applicable.

**CAUTION**

Follow clamp-on ohmmeter manufacturer's warning and caution information.

D.5.3.3 Single Grounding (Earthing) Electrode System Testing (or Equivalent)

For a site using a single grounding electrode system (or equivalent), perform test as follows:

1. Locate the grounding electrode connection outside of the shelter or the single wire connecting to the grounding electrode.
2. Clamp the meter around the grounding electrode connecting wire, making sure that the meter is positioned at a location below any other utility connection (such as the telephone service provider ground or a water pipe). See Figure D-15 and Figure D-16 for examples.
3. Set the meter to the **Amps** scale and check the grounding electrode for current. Any current on the grounding electrode conductor (even if less than 3 – 5 amps) can result in a false reading. See the meter's User Manual for error conditions resulting from excessive current flow.

**WARNING**

Any significant current on the grounding electrode conductor could indicate a serious problem and should be immediately investigated by qualified personnel. Motorola Solutions recommends any current above 500mA be reported to the site owner and properly investigated (the current loading at the site can have a direct impact on this reading; therefore, this current should be measured when the site is at operational load). Consultation with the Authority Having Jurisdiction (AHJ) and/or an electrical engineering firm should be considered.

4. Set the meter to the **Ohms** scale and note the reading; if no noise or other errors are indicated on the meter, this is the resistance of the grounding electrode system under test.
5. Record the reading on the photocopy of the Clamp-on Ohmmeter/Ammeter Test worksheet (page D-34). A digital photograph showing the meter location and displayed resistance value is also recommended.

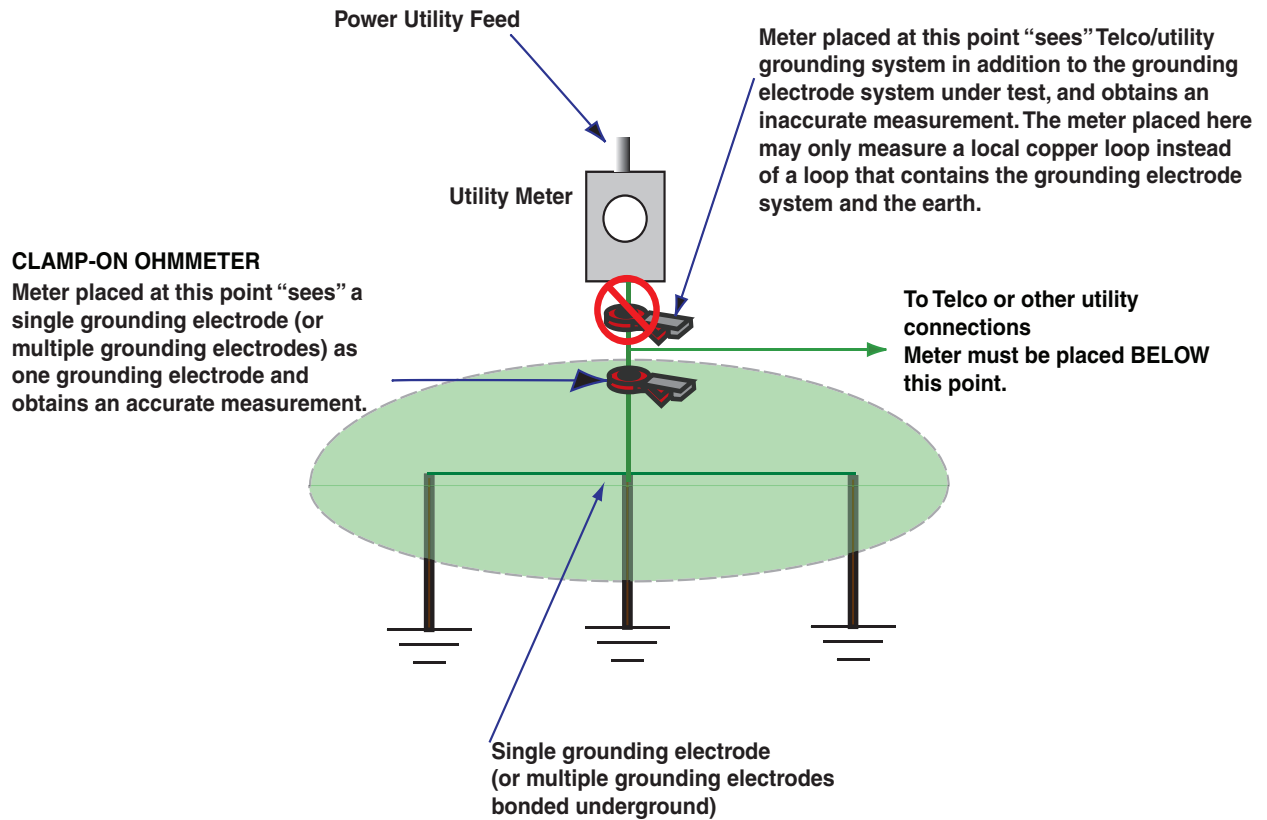

©Motorola Solutions, Inc. All rights reserved.

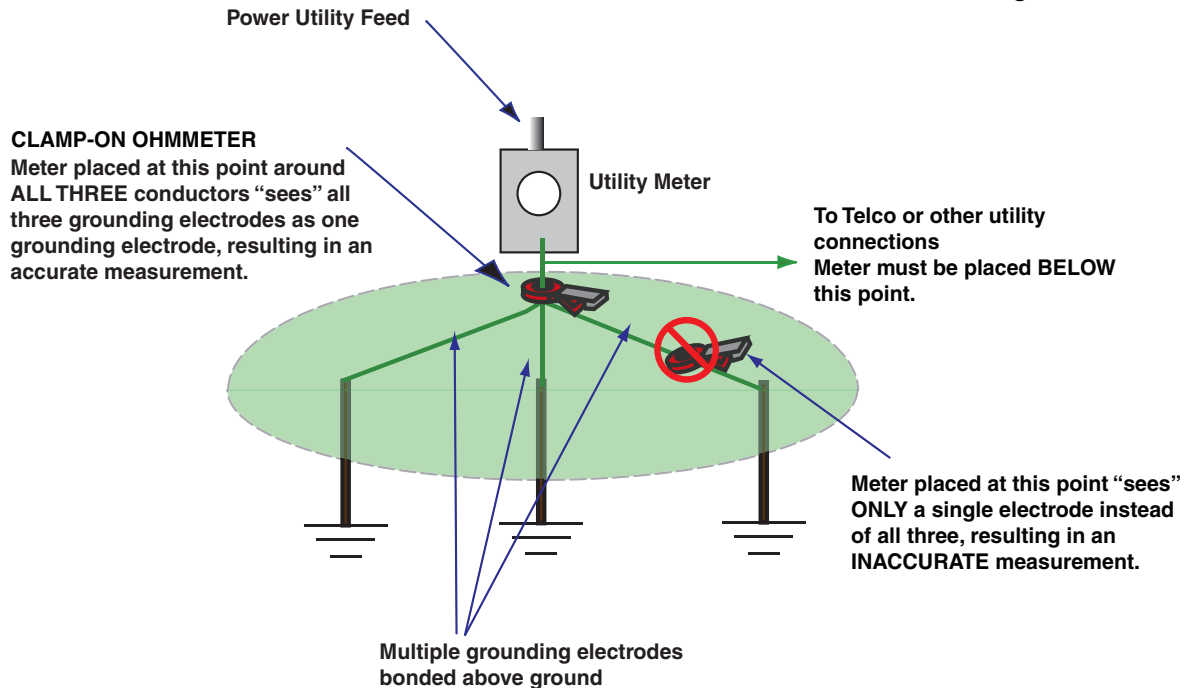

Figure D-15 Clamp-On Ohmmeter Placement

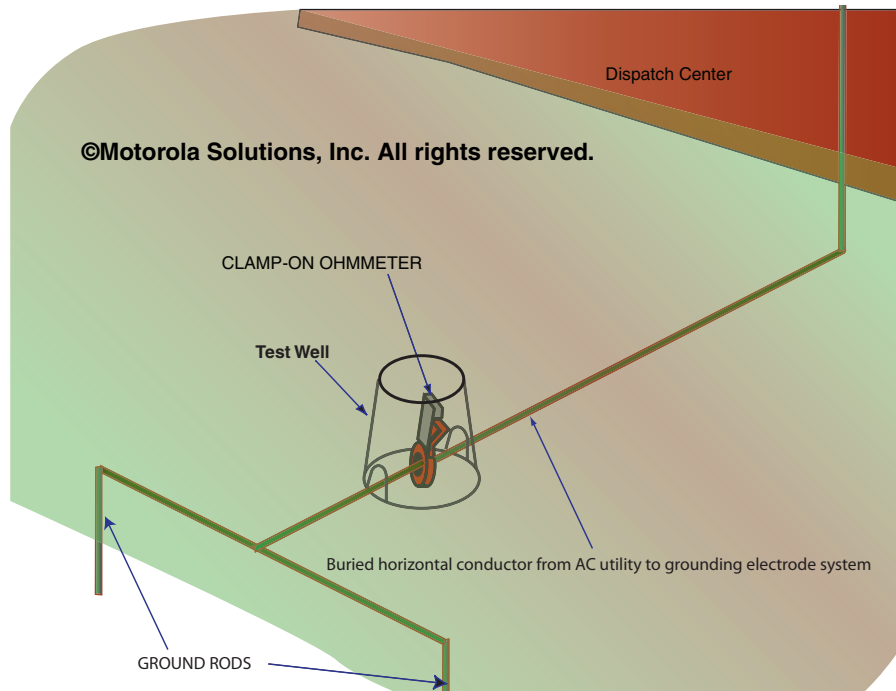

Figure D-16 Clamp-on Ohmmeter Placement For Parallel Grounding Electrode System (Site without a Tower)

D.5.3.4 Multi-Bonded Complex Grounding (Earthing) Electrode System Testing

For a site using a multi-bonded complex grounding electrode system (typical at a communications site), perform the test as follows:



IMPORTANT

This test requires the site grounding electrode system to be bonded to the power utility neutral wire, but may require all non-balanced (phase-to-neutral) loads within the site to be switched off or transferred to a backup power source.



NOTE

The neutral wire is used for this measurement because it is typically the only point at the site where all of the site grounding connections are combined onto a single conductor and downstream to the meter. As such, measuring at this point allows the clamp-on ohmmeter to “view” all of the various connections as one single grounding electrode.

1. Follow the steps as described in “Site AC Power Disconnect Requirements” on page D-21.
2. Disconnect any other utility connections to the grounding electrode system, such as the telephone service provider ground.



WARNING

Lethal voltages may be present. Only qualified personnel SHALL open an electrical panel to attempt a ground resistance measurement.

3. Have the power utility neutral wire exposed by a qualified electrician at the point of entry into the site (before it makes any bond to the site), ensuring that it has no secondary path to the site via a conduit or other connection.

**NOTE**

See the meter user's manual to determine a meter indication, if any, showing that the meter is reading a closed loop rather than the actual grounding electrode system. The closed loop reading may be caused by a ground loop through a conduit, electrical service meter base or any other electrical panelboard. It may also be an indication that there is another utility connected, such as a water pipe or the telephone service provider ground. An extremely low reading (such as < 0.5 ohms) may also be an indication of a closed loop reading.

**NOTE**

In many cases, the first neutral-ground bonding point may not be at the building electrical service panel, but rather in the meter box where the neutral is bonded to the meter chassis (and metallic conduit). In this situation, if a measurement is attempted at the electrical service panel, the meter displays an erroneous closed-loop reading instead of a reading of the grounding electrode system (see Figures D-17, D-18 and D-19 for examples and testing options). If the electrical service enters the building in a PVC conduit, this situation typically does not apply. As such, a grounding electrode system resistance reading can be made in the electrical service panel. Consultation with an engineering firm is recommended.

- Depending on the location of the first neutral-ground bonding point, attach the clamp-on ohmmeter around the neutral wire as shown in Figures D-17, D-18 and D-19.

**WARNING**

Lethal voltages may be present. Only qualified personnel SHALL open an electrical panel to attempt a ground resistance measurement.

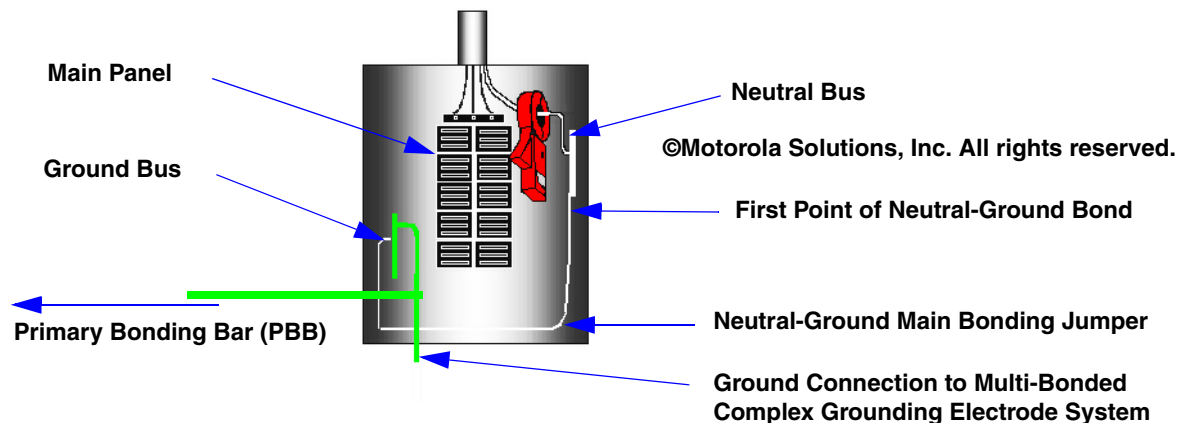

Figure D-17 Clamp-on Ohmmeter Placement For Multi-Bonded Complex Grounding Electrode System (Neutral-Ground Bond at Service Panel)

- Set the meter to the Amps scale and verify there is no significant current on the neutral wire.

**NOTE**

Unbalanced current flow (current on the neutral wire) may affect the ability of the meter to achieve an accurate reading. Therefore, arrange for any non-balanced (phase-to-neutral) loads within the site to be electrically de-energized, so that there is no current flow on the neutral conductor. The easiest way to accomplish this is to completely de-energize the AC power to the site. Any current on the neutral wire (even if less than 3 - 5 amps) may result in a false reading.

6. Set the meter to the Ohms scale and note the reading. If no noise or other errors are indicated on the meter, this is the resistance of the grounding electrode system under test.
7. Record the reading on the photocopy of the Clamp-on Ohmmeter/Ammeter Test Worksheet on page D-34. A digital photograph showing the meter location and displayed resistance value is also recommended.

Neutral bonding inside meter box and metallic conduit makes reading taken in building impossible.

Reading must be taken on the power utility side of this bond.

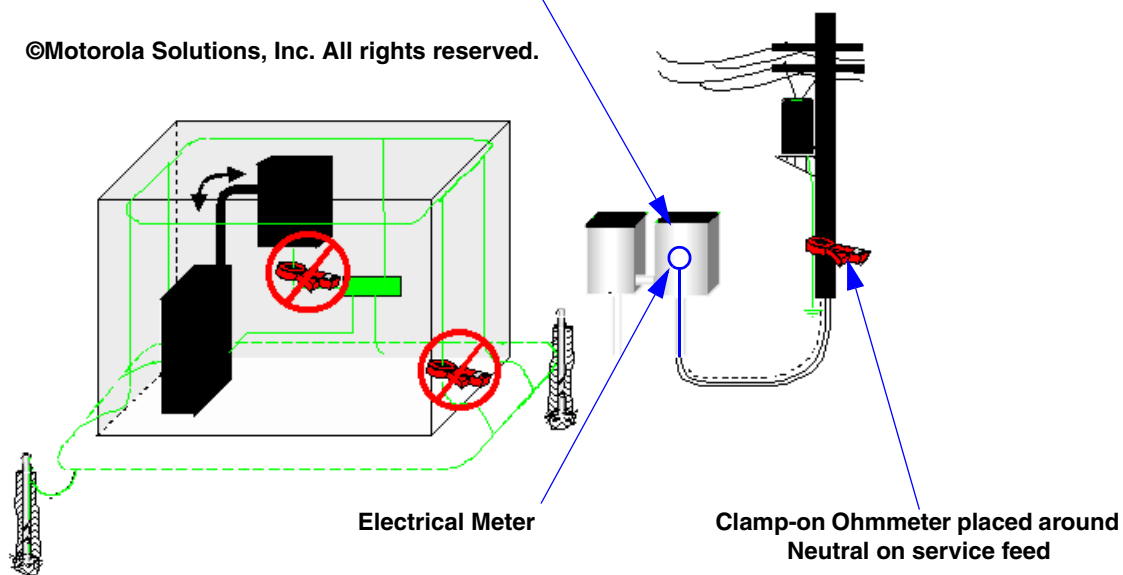

Figure D-18 Clamp-on Ohmmeter Placement for Multi-Bonded Complex Grounding Electrode System (Underground Service)

! WARNING

Measurements at these locations **SHALL** only be made under the direct supervision of the power utility.

! WARNING

Appropriate fall restraint and fall arrest techniques **SHALL** be observed when climbing or when using any kind of personnel lift. Applicable national and local codes **SHALL** be followed.

**Neutral bonding inside meter box and metallic conduit makes reading taken in building impossible.
Reading must be taken on the power utility side of this bond.**

©Motorola Solutions, Inc. All rights reserved.

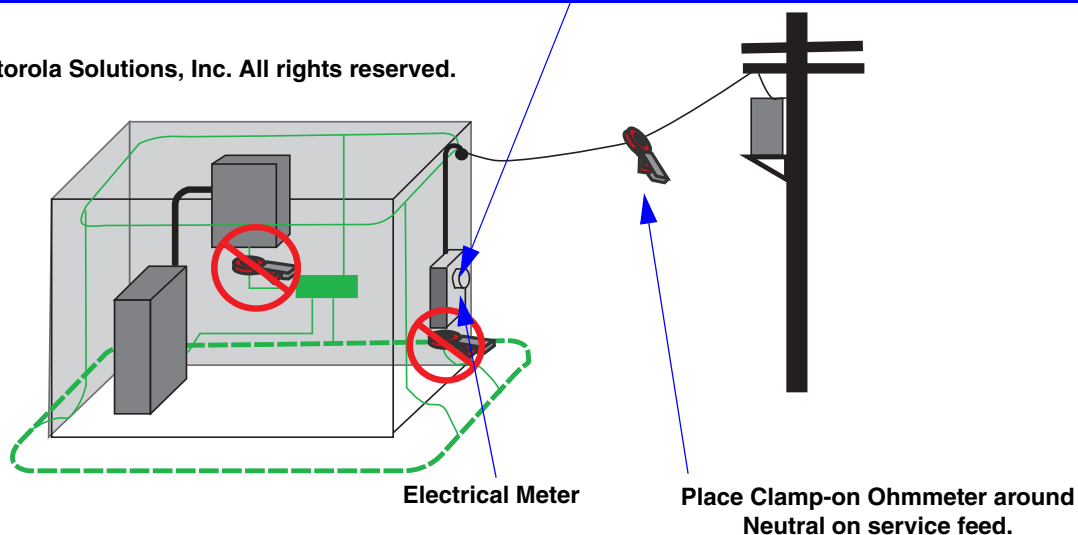

Figure D-19 Clamp-on Ohmmeter Placement For Multi-Bonded Complex Grounding Electrode System (Overhead Service)



WARNING

Measurements at these locations **SHALL** only be made under the direct supervision of the power utility.



WARNING

Appropriate fall restraint and fall arrest techniques **SHALL** be observed when climbing or when using any kind of personnel lift. Applicable national and local codes **SHALL** be followed.

Temporary Jumper to Ground System of Nearby Site

©Motorola Solutions, Inc. All rights reserved.

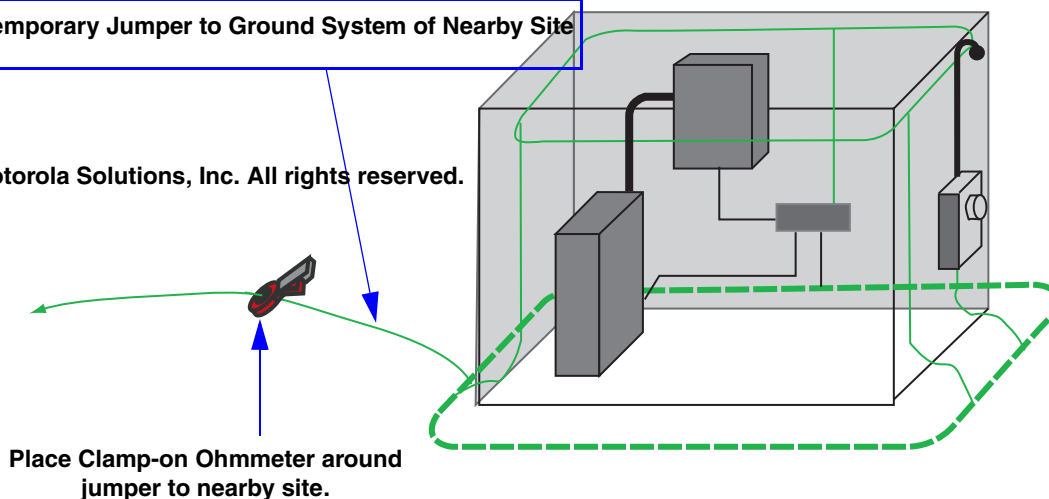

Figure D-20 Clamp-on Ohmmeter Placement For Multi-Bonded Complex Grounding Electrode System (Before AC Utility is Connected)

D.5.4 Clamp-on Ohmmeter Bonding Continuity Testing

Because the clamp-on ohmmeter works on the basis of inducing a low-frequency test current (usually between 1 kHz and 3.4 kHz), from a known voltage source, into a conductive loop, most conductive loops at a communications site can be measured with a clamp-on ohmmeter. See Figure D-12 for loop examples. It is up to the meter operator to determine and understand the loop being tested. The placement of the meter typically determines the loop being tested. An experienced operator can determine how to measure most common loops at a communications site.

All bonding connections **shall be** verified during installation. Table D-5 provides some guidance on the expected measured values at some common test locations. It is assumed that the site is properly grounded and bonded and equipment (including coaxes) is installed and plugged into an AC power receptacle. This table is for general guidance only and is not indicative of all sites.

Table D-5 COMMON GROUND TEST LOCATIONS AND TYPICAL MEASURED VALUES

Clamp-on Ohmmeter Test Location	Typical Value *	Notes
External Ground Bus Bar (EGB) grounding electrode conductor	< 0.2 ohms	The primary loop is through the grounding electrode system, to the tower structure, to the grounded coaxes, to the EGB and returning to the EGB grounding electrode conductor. A secondary loop may also exist through the grounded coaxes, to the lightning protection unit, to the Primary Bonding Bar (PBB), to the grounding electrode system and returning on the EGB grounding electrode conductor.
Bottom Tower Ground Bus Bar (TGB) grounding electrode conductor	< 0.2 ohms	The primary loop is through the grounding electrode system, to the EGB grounding electrode conductor, to the EGB and returning to the TGB through the grounded coaxes. Other secondary loops may exist.
Tower leg grounding electrode conductor (each tower leg conductor should be tested)	< 0.2 ohms	The primary loop is through the tower grounding electrode conductor, to tower ground ring, to the tower structure via another tower grounding electrode conductor and returning through the tower structure. Higher resistance values may indicate bonding problems or the lack of a tower ground ring. Higher resistance values that vary at each tower leg and have resistance values for a typical ground rod in the given soil is further indication that no tower ground ring is present.
Ice bridge support post grounding conductor	< 0.5 ohms	The primary loop is through the grounding electrode system, to another ice bridge support post and returning to the support post under test via the ice bridge structure.
Externally mounted HVAC unit bonding conductor	< 0.5 ohms	The primary loop is completed via the HVAC AC power source grounding conductor (safety ground).
Remote fuel tank bonding conductor (with non-conductive fuel line)	High	There is not typically a complete conductive loop. If a high resistance reading is encountered, install a temporary test jumper from the tank to a reliable ground point (such as an EGB). If the tank bonding connection is adequate, the measured value should drop to < 0.5 ohms. Remove the temporary test jumper.
Remote fuel tank bonding conductor (with conductive fuel line)	< 0.5 ohms	The primary loop is completed through the conductive fuel line if the fuel line is bonded to the site. If a high resistance reading is encountered, install a temporary test jumper from the tank to a reliable ground point (such as an EGB). If the tank bonding connection is adequate, the measured value should drop to < 0.5 ohms. Remove the temporary test jumper.
Fence post grounding conductor	Variable	The primary loop is typically through the mechanical connections of the fence fabric, returning via another grounded fence post. If a high reading is encountered, install a temporary test jumper from the fence post being measured to a reliable ground point (such as an EGB). If the fence post bonding connection is adequate, the measured value should drop to < 0.5 ohms. Remove the temporary test jumper.
* Some clamp-on ohmmeters are not capable of reading below 0.7 ohms. See the meter's User Manual for complete details.		

Table D-5 COMMON GROUND TEST LOCATIONS AND TYPICAL MEASURED VALUES (CONTINUED)

Clamp-on Ohmmeter Test Location	Typical Value *	Notes
Gate post grounding conductor	Variable	The primary loop is typically through the mechanical connections of the fence fabric, returning via a grounded fence post. If a high reading is encountered, install a temporary test jumper from the gate post being measured to a reliable ground point (such as an EGB). If the gate post bonding connection is adequate, the measured value should drop to < 0.5 ohms. Remove the temporary test jumper. A drop in resistance reading is typically observed when the gate is closed and latched.
Generator bonding conductor	< 0.2 ohms	The primary loop is completed via the AC power grounding conductor (safety ground).
Miscellaneous isolated metallic objects (vent covers, metallic roof flashing, metallic siding, hand rails, and so on)	High	There is not typically a complete conductive loop for several miscellaneous metallic objects (internal and external). If a high resistance reading is encountered, install a temporary test jumper from the object to a reliable ground point (such as an EGB or PBB). If the object bonding connection is adequate, the measured value should drop to < 0.5 ohms. Remove the temporary test jumper.
Primary Bonding Bar (PBB)/Master Ground Bus Bar (MGB) grounding electrode conductor	< 0.2 ohms	The primary loop is through the MGB grounding electrode conductor, to the grounding electrode system, to the EGB grounding electrode conductor, to the EGB and returning via the grounded coaxes.
Rack Bonding Bar (RBB) grounding conductor	< 0.2 ohms	The primary loop is typically completed through the internal grounding system and the equipment AC power source grounding conductor (safety ground). Other secondary loops may exist.
Secondary Bonding Bar (SBB)/Sub System Ground Bus Bar (SSGB) grounding conductor	< 0.2 ohms	The primary loop is typically completed through the internal grounding system and the equipment AC power source grounding conductor (safety ground). Other secondary loops may exist.
Equipment bonding conductors	< 0.2 ohms	The primary loop is typically completed through the internal grounding system and the equipment AC power source grounding conductor (safety ground). Other secondary loops may exist, such as through the grounded equipment rack.
* Some clamp-on ohmmeters are not capable of reading below 0.7 ohms. See the meter's User Manual for complete details.		

D.6 Combining Soil Resistivity Testing with Clamp-On Ohmmeter

Providing site soil resistivity readings along with clamp-on ohmmeter readings to an engineering firm specializing in grounding electrode system design is at times the only method available for grounding electrode system resistance verification.

Typically, the engineering firm enters the supplied data into a specialized computer program that determines grounding electrode system resistance for the site. The typical data required is as follows (consult with the engineering firm for specific requirements):

- The results obtained from a soil resistivity test
- Individual grounding electrode system component testing data from the clamp-on ohmmeter
- Detailed grounding electrode system *as-built* drawings for the site

Table D-6 FALL-OF-POTENTIAL TEST WORKSHEET

Distance from Grounding Electrode System Grid		Test Data
%	ft (m)	Ohms (Ω)
1%		
5%		
10%		
20%		
30%		
40%		
50%		
60%		
70%		
80%		
90%		
99%		
Test completed by:		
Date:		
Client / Project:		
Site Location/ID:		
Ground Resistance Tester		
Model:		
S/N:		
Calibration date:		
Soil Description:		
Ambient Conditions		
Temperature:		
Present conditions (dry, rain, snow):		
Date of last precipitation:		
Notes:		

THIS PAGE INTENTIONALLY LEFT BLANK.

©Motorola Solutions, Inc. All rights reserved.

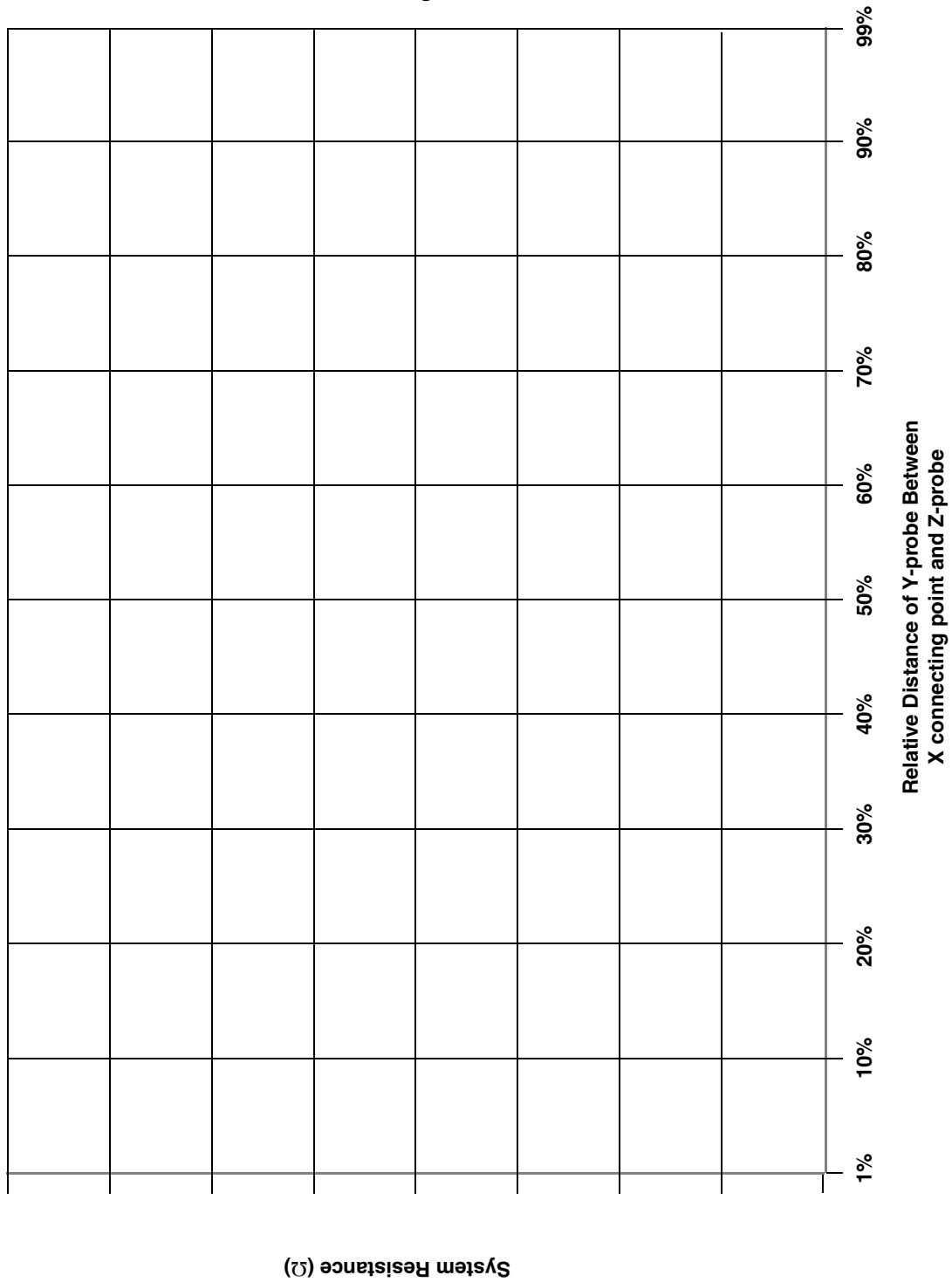

Figure D-21 Fall-of-Potential Test Graph Form

THIS PAGE INTENTIONALLY LEFT BLANK.

Table D-7 CLAMP-ON OHMMETER/AMMETER TEST WORKSHEET

Points Tested	Ohms	Amps
Test Point 1:		
Test Point 2:		
Test Point 3:		
Test Point 4:		
Test Point 5:		
Test Point 6:		
Test Point 7:		
Test completed by:		
Date:		
Client / Project:		
Site Location/ID:		
Ground Resistance Tester		
Model:		
S/N:		
Calibration date:		
Soil Description:		
Ambient Conditions		
Temperature:		
Present conditions (dry, rain, snow):		
Date of last precipitation:		
Notes:		

General Conversions and Formulas

Table E-1 CONVERSION FORMULAS

Conversion Formulas
Linear Measure
miles (statute) = miles (nautical) x 1.1508
mils = in x (1 x 10 ³)
ft = in/12
yard = ft/3
miles = ft/5280
Volume
ounce (fluid) = qt x 32
pint = qt x 2
gallon (US) = qt/4
gallon (imperial) = gallon (US)/0.8327
gallon (US) = cu. ft / 7.477
Avoirdupois Weight
ounce = lb x 16
short ton = lb/2000
long ton (UK) = lb/2240
Temperature
°C = (°F-32)/1.8
°F = (°C·1.8) + 32
°K (Kelvin; Celsius absolute) = °C + 273.18
°R (Rankine; Fahrenheit absolute) = °F + 459.72
Angular Measurement
radians = degrees x 0.0145
revolutions = radians x 2π
Sinusoidal Waveform Measurement
rms = average x 1.11
peak = average x 1.57
peak-to-peak = average x 3.14

Table E-1 CONVERSION FORMULAS (CONTINUED)**Conversion Formulas**

$$\text{average} = \text{rms} \times 0.9$$

$$\text{peak} = \text{rms} \times 1.414$$

$$\text{peak-to-peak} = \text{rms} \times 2.828$$

$$\text{average} = \text{peak} \times 0.637$$

$$\text{rms} = \text{peak} \times 0.707$$

$$\text{peak-to-peak} = \text{peak} \times 2$$

Power

$$\text{hp} = \text{W} / 746$$

$$\text{BTU/hr} = \text{W} / 0.293$$

Energy

$$\text{BTU} = \text{KWh} / (2.9306 \times 10^{-4})$$

Metric Conversion Formulas**Linear Measure**

$$\text{cm} = \text{in} \times 2.54$$

$$\text{in} = \text{centimeters} \times 0.3937$$

$$\text{in} = \text{meters} \times 39.37$$

$$\text{yards} = \text{meters} \times 1.0936$$

$$\text{ft} = \text{kilometers} \times 3281$$

$$\text{kilometers} = \text{miles (statute)} \times 1.6093$$

$$\text{micron} = \text{meter} / 10^{-6}$$

$$\text{millimicron} = \text{meter} / 10^{-9}$$

$$\text{Angstrom units} = \text{meter} / 10^{-10}$$

Area

$$\text{cm}^2 = \text{sq. in} / 0.155$$

$$\text{m}^2 = \text{sq. ft} / 10.76$$

$$\text{square miles} = \text{km}^2 / 0.3816$$

$$\text{km}^2 = 0.3861 \text{ square mile}$$

Liquid Measure

$$\text{US gallon} = \text{liter} \times 0.2642$$

$$\text{fluid ounce} = \text{milliliter} \times 0.0338$$

Volume

Table E-1 CONVERSION FORMULAS (CONTINUED)

Conversion Formulas
liter = 1000 cm ³ = cu. in / 61.02
Pressure
Pa = N/m ² = PSF x 47.85
Pa = PSI x 6891
atm = PSF x 2117
Weight
ounce = gram x 0.03527
lb = kilogram x 2.2046
gram = ounce x 28.35
kilogram = lb x 0.4536
US short ton = 2000 lb = metric tonnes x 0.9072
UK long ton = 2240 lb = metric tonnes x 1.1023
metric tonne = 1000 kg = UK long tons x 0.9842
metric tonne = 1000 kg = US short tons x 1.1023
Torque
N·m = lbf·ft x 1.356
lbf·ft = N·m x 0.7376

Table 5-1 METRIC EQUIVALENTS OF AMERICAN WIRE GAUGE (AWG)

AWG	Area			Diameter	
	c mils	inches ¹	mm ²	mils	mm
28	159.8	0.000126	0.804	12.6	0.320
26	254.1	0.000200	0.128	15.9	0.404
24	404.0	0.000317	0.205	20.1	0.511
22	642.4	0.000505	0.324	25.3	0.643
19	1288	0.001012	0.653	35.9	0.912
18	1624	0.001276	0.823	40.3	1.02
16	2583	0.002028	1.31	50.8	1.29
15	3257	0.002558	1.65	57.1	1.45
14	4107	0.003225	2.08	64.1	1.63
13	5178	0.004067	2.63	72.0	1.83
12	6530	0.005129	3.310	80.0	2.05
11	8234	0.006467	4.17	90.7	2.304
10	10380	0.008155	5.261	101.9	2.588
9	13090	0.01028	6.631	114.4	2.906
8	16510	0.01297	8.367	128.5	3.264
7	20820	0.01635	10.55	144.3	3.665
6	26250	0.02062	13.30	162.0	4.115
5	33100	0.02600	16.77	181.9	4.520
4	41740	0.03278	21.15	204.3	5.189
3	52640	0.04134	26.67	229.4	5.827

Table 5-1 METRIC EQUIVALENTS OF AMERICAN WIRE GAUGE (AWG)

AWG	Area			Diameter	
	c mils	inches ¹	mm ²	mils	mm
2	66370	0.05213	33.62	257.6	6.543
1	83690	0.06573	42.41	289.3	7.346
1/0	10550	0.08289	53.49	324.9	8.252
2/0	13310	0.1045	67.43	364.8	9.266
3/0	167800	0.1318	85.01	409.6	10.40
4/0	211600	0.1662	107.26	460.0	11.68
	250000		126.70	500.0	12.70
	350000		177.39		
	500000		253.35		
	750000		380.13		

1. All conductors are solid except AWG 2 and coarser which are stranded.

Table 5-2 TEMPERATURE CONVERSION CHART

°C	°F	°C	°F	°C	°F	°C	°F
-60	-76	-25	-13	5	41	45	113
-55	-67	-20	-4	10	50	50	122
-50	-58	-17.8	0	15	59	55	131
-45	-49	-15	5	20	68	60	140
-40	-40	-10	14	30	86	65	149
-35	-31	-5	23	35	95	70	158
-30	-22	0	32	40	104		

NOTE: °C= (°F-32) / 1.8
°F= (°C·1.8) + 32

Table 5-3 ENGINEERING PREFIXES

Prefix	Symbol	Value	Example
tera	T	1×10^{12}	terahertz (THz)
giga	G	1×10^9	gigahertz (GHz)
mega	M	1×10^6	megahertz (MHz)
kilo	k	1×10^3	kilohertz (kHz)
centi	c	1×10^{-2}	centimeter (cm)
milli	m	1×10^{-3}	millihenry (mH)
micro	μ	1×10^{-6}	microfarad (μ F)
nano	n	1×10^{-9}	nanosecond (nsec)
pico	p	1×10^{-12}	picofarad (pF)

Table E-2 DECIMAL EQUIVALENT DRILL SIZES

Fractional Drill Size (in.)	Decimal Equivalent (in.)	Metric Equivalent (mm)	Fractional Drill Size (in.)	Decimal Equivalent (in.)	Metric Equivalent (mm)
1/64	0.0156	0.397	33/64	0.5156	13.097
1/32	0.0313	0.794	17/32	0.5313	13.494
3/64	0.0469	1.191	35/64	0.5469	13.891
1/16	0.0625	1.588	9/16	0.5625	14.287
5/64	0.0781	1.985	37/64	0.5781	14.684
3/32	0.0938	2.381	19/32	0.5938	15.081
7/64	0.0194	2.778	39/64	0.6094	15.478
1/8	0.125	3.175	5/8	0.625	15.875
9/64	0.1406	3.572	41/64	0.6406	16.272
5/32	0.1563	3.969	21/32	0.6563	16.669
11/64	0.1719	4.366	43/64	0.6719	17.067
3/16	0.1875	4.762	11/16	0.6875	17.463
13/64	0.2031	5.159	45/64	0.7031	17.86
7/32	0.2188	5.556	23/32	0.7188	18.238
15/64	0.2344	5.953	47/64	0.7344	18.635
1/4	0.25	6.35	3/4	0.75	19.049
17/64	0.2656	6.747	49/64	0.7656	19.446
9/32	0.2813	7.144	25/32	0.7813	19.842

Table E-2 DECIMAL EQUIVALENT DRILL SIZES (CONTINUED)

Fractional Drill Size (in.)	Decimal Equivalent (in.)	Metric Equivalent (mm)	Fractional Drill Size (in.)	Decimal Equivalent (in.)	Metric Equivalent (mm)
19/64	0.2969	7.541	51/64	0.7969	20.239
5/16	0.3125	7.937	13/16	0.8125	20.636
21/64	0.3281	8.334	53/64	0.8281	21.033
11/32	0.3438	8.731	27/32	0.8438	21.43
23/64	0.3594	9.128	55/64	0.8594	21.827
3/8	0.375	9.525	7/8	0.875	22.224
25/64	0.3906	9.922	57/64	0.8906	22.621
13/32	0.4063	10.319	29/32	0.9063	23.018
27/64	0.4219	10.716	59/64	0.9219	23.415
7/16	0.4375	11.112	15/16	0.9375	23.812
29/64	0.4531	11.509	61/64	0.9531	24.209
15/32	0.4688	11.906	31/32	0.9688	24.606
31/64	0.4844	12.303	63/64	0.9844	25.004
1/2	0.5	12.7	1	1.0	25.4

Table 5-1 POWERS OF 10

Unit	Name
$10^{12} = 1\,000\,000\,000\,000$	1 trillion (US, France) 1 billion (UK, Germany)
$10^9 = 1\,000\,000\,000$	1 billion (US) 1 milliard (France and Germany)
$10^6 = 1\,000\,000$	1 million
$10^3 = 1\,000$	1 thousand
$10^2 = 100$	1 hundred
$10^1 = 10$	ten
$10^0 = 1$	one (unity)
$10^{-1} = 0.1$	1 tenth
$10^{-2} = 0.01$	1 hundredth
$10^{-3} = 0.001$	1 thousandth
$10^{-6} = 0.000\,001$	1 millionth
$10^{-9} = 0.000\,000\,001$	1 billionth (US)

Table 5-1 POWERS OF 10 (CONTINUED)

Unit	Name
$10^{-12} = 0.000\ 000\ 000\ 001$	1 trillionth (US)

R56 Compliance Checklist

This checklist is provided as a guide to help prepare a site for mission critical use. This checklist is not a substitute an R56 compliance audit performed by a certified R56 Auditor.

F.1 Building Design and Installation

- All utility entrances to the facility should be located in the same general area of the shelter and should be located as close together as is practicable.
- Ceiling height is sufficient for equipment installation.
- Cable tray system meets requirements.
- Floor has been sealed as required.
- All transmission line entry ports, holes or openings that penetrate the outer surface of the building are properly sealed as required.
- Lighting requirements have been met.
- Appropriate heating and air conditioning are provided.
- Fire suppression equipment has been installed.
- First aid kit is available.
- Personal protective safety equipment is available for personnel working around batteries.
- Telephone, microwave link or cellular phone is available at the site.
- Phone numbers of importance are posted.
- Minimum required signage is posted in accordance with local regulations.

F.2 External Grounding (Earthing) and Bonding System

- Lightning exposure at the site has been reviewed and considered.
- External Ground Bus Bar (EGB) is properly installed at transmission line entry point.
- EGB grounding electrode conductor is properly installed.
- Soil conditions at the site have been reviewed, and grounding electrode system components have been selected accordingly.
- A grounding electrode system that is appropriated for the site (for example, dedicated communications building, outdoor cabinet, Type A site, Type B site or Type B2) is installed.
- All grounding electrodes at the site are bonded together, forming a common grounding electrode system.
- Grounding electrodes installed meet specifications and installation requirements.
- Concrete-encased electrodes are considered for new construction.
- Building and tower ground rings (where required) are properly installed, and ground rods are installed every 3.05 – 4.6 m (0 – 15 ft).
- Where used, radial grounding conductors are properly installed.
- Where used, grounding electrode encasement materials meet specifications and installation requirements.

- All grounding conductors meet specifications and are properly installed.
- All grounding conductors have been routed in a continuous downward direction toward the EGB, TGB or grounding electrode system, with no sharp bends.
- Grounding conductors are routed as straight as practicable and protected from physical damage as required.
- Grounding conductors are securely fastened as required.
- Grounding conductors meet or exceed the conductor size requirements.
- Braided grounding conductors are not used anywhere in the external grounding system.
- Galvanic corrosion has been considered and installation techniques have been employed to help prevent galvanic corrosion.
- Approved bonding techniques are used to bond dissimilar metals.
- Approved methods are used for conductor connection and termination.
- Bonding surfaces for lugs and clamps are free of paint and corrosion, and a conductive anti-oxidant compound has been applied.
- Painted or galvanized bonding surfaces for exothermic welding were cleaned and painted to inhibit rusting.
- The grounding electrode system resistance requirements are met. If not, supplemental grounding electrode system components have been installed.
- The tower is properly grounded and bonded, with the required number of grounding conductors.
- Guy anchor points for guyed towers are properly grounded in a manner that will minimize galvanic corrosion.
- Generators external to the building are properly grounded and bonded.
- A Tower Ground Bar (TGB) (if required) is properly installed.
- Tower mounted antenna preamplifiers are properly grounded/bonded to the tower.
- Each transmission line outer shield is properly bonded to the tower at the top of the tower near the antenna with a weather sealed transmission line grounding kit.
- Each transmission line outer shield is properly bonded to the tower or to a TGB at the vertical-to-horizontal transition point (toward the building) with a weather sealed transmission line grounding kit.
- Each transmission line outer shield is properly bonded to the tower with a weather sealed transmission line grounding kit at intervals not exceeding 61 m (200 ft).
- Each transmission line outer shield is properly bonded to the EGB (or grounding electrode system) with a weather sealed transmission line grounding kit.
- All fencing, gates and gate support posts are properly bonded to the grounding electrode system.
- Ice bridge/cable supports and posts are properly bonded to the grounding electrode system.
- The following items, and other metallic items located within 1.8 m (6 ft) of the grounding electrode system or within 1.8 m (6 ft) of grounded objects, are properly bonded to the grounding electrode system as applicable:
 - Metallic members of all incoming telecommunications cables
 - Main electrical ground
 - Main telephone ground
 - Any other grounding electrode system at the site
 - Metallic entry ports
 - Metallic conduits, piping and raceways

- HVAC units
 - Vent covers and grates (if not already grounded/bonded inside)
 - Metal siding and/or roofing
 - Metal fuel storage tanks (above or below ground)
 - Skid plate or metal support frame of a prefabricated shelter
 - Metallic structures for antenna supports, light fixtures, and so on.
 - Handrails and safety rails
 - Ladders and safety cages
- Roof-Mounted antenna masts and metal support structures are properly grounded.
 - Building side mounted antennas are properly grounded.
 - Rooftop mounted towers are properly grounded.
 - Dispatch centers co-located with communications towers have considered additional grounding components/techniques to help improve protection of the site.
 - Special grounding situations have followed minimum recommendations.
 - All grounding/bonding connections have been tested for continuity using a clamp-on ground resistance meter (clamp-on ohmmeter).

F.3 Internal Bonding and Grounding System

- A properly sized Primary Bus Bar (PBB) is installed as required.
- The PBB grounding electrode conductor has been properly bonded and routed toward the grounding electrode system.
- All conductor connections to the PBB follow approved connection methods.
- Secondary Bonding Bar (SBB), if required, is properly installed.
- SBBs are bonded to the PBB as required.
- All conductor connections to the SBB follow approved connection methods.
- Where required, an Internal Perimeter Bonding Bus (IPBB) is properly installed.
- Only ancillary equipment is bonded to the IPBB.
- Each ancillary support apparatus is properly bonded to the PBB, SBB or IPBB.
- Exposed structural metal is properly bonded to the PBB or SBB as required.
- Raised flooring is bonded to the PBB, SBB or bonding grid as required.
- False ceiling support grid is bonded to the PBB or SBB as required.
- Surge Protective Device (SPD) metal housings are bonded to the PBB, SBB or IPBB as required.
- Separately derived AC or DC electrical systems are bonded to the PBB or SBB as required.
- Primary telephone, control and data network circuit SPDs are bonded to the PBB or SBB as required.
- RF transmission line SPDs are bonded to the PBB or a separate equipment area SBB as required.
- Cable trays are bonded to the PBB or SBB as required.
- Each cable tray section is bonded to the adjoining section as required.
- Bonding bus conductors and their branches are sized as required.

- All bonding bus conductors, bonding bus branches and equipment bonding conductors are routed toward the PBB or SBB as required.
- Bonding connections to a bonding bus or its branch have been properly insulated as required.
- Racks and cabinets have been properly bonded to the PBB, SBB, bonding bus or Rack Bonding Bar (RBB) using approved methods.
- Any Rack Bonding Bar (RBB) located within a rack or cabinet has been properly bonded to the PBB, SBB or bonding bus using approved methods.
- Individual system component chassis equipment is properly bonded as required.
- Secondary telephone, control and data network circuit SPDs are properly insulated and bonded to the PBB, RBB or SBB as required.
- All required control center and dispatch equipment is properly bonded to the PBB, SBB, bonding grid or bonding bus conductor as required.
- All grounding/bonding connections have been tested for continuity using a clamp-on ground resistance meter (clamp-on ohmmeter).

F.4 Power Sources

- Circuit breakers are labeled to identify the receptacle outlet they are protecting.
- Electrical subpanels are labeled to identify their source.
- Power panels (panelboards) are installed with proper clearance requirements.
- Power receptacles are permanently marked to identify their assigned circuit breakers and panels.
- Power receptacles are securely mounted to the supporting structure.
- Equipment grounding conductors have been installed in the power receptacles as required.
- AC power receptacles have been tested and meet requirements.
- Adequate service receptacles are provided for the service technician.
- Each critical piece of equipment has a dedicated branch circuit and dedicated simplex receptacle.
- Power receptacles are installed by the equipment load as required.
- Extension cords, including consumer-grade outlet strips, are not used in the final installation.
- Exterior receptacle outlets and circuits are GFCI protected as required.
- AC power receptacles and strips are of the proper type and are securely mounted as required.
- UPS and battery banks are installed with sufficient clearance to allow servicing.
- The neutral-ground bonding conductor has been properly installed in the main service disconnect as required.
- Solar panels are installed away from objects that could damage or block sunlight to the panel.
- Solar panels and wind generators are installed using proper mounting practices.
- Battery racks are bolted to the floor or wall.
- Battery cables (multi-conductor assemblies) installed in cables trays are listed as Tray Cable (TC) rated or are enclosed in an approved conduit or raceway.
- Battery conductors (individual conductors not part of a cable assembly) installed in cable trays are enclosed in an approved conduit or raceway.
- Battery conductors are protected up to near the point of termination.

- DC plant terminations are protected from accidental contact.
- A battery disconnect and suitable circuit protection device has been installed as required.
- Standby power generator (if installed) is installed properly.
- Standby power generator is located in an area accessible only by authorized personnel.
- Standby power generators are installed with adequate area for servicing.
- Fuel storage tanks for standby power generators are located in a secure area.
- A dedicated electrical circuit has been provided at the generator.
- A transfer switch of the proper ampacity rating has been installed to perform the switching between commercial power and standby generator power.
- A main service disconnect has been installed as required.
- Electrical panelboard ampacity ratings are properly coordinated.

F.5 Surge Protective Devices (SPD)

- All electrically conductive points of entry (for example, AC power, telephone, LAN, signal/control and RF) into a site are protected from surges using a surge protective device.
- SAD/MOV SPDs (Type 2A or 2B) for AC power are properly installed as required.
- Primary SPDs for telephone circuits are installed as required.
- Secondary SPDs for telephone circuits are installed as required.
- Primary SPDs for control circuits are installed as required.
- Primary SPDs for data network circuits are installed as required.
- Secondary SPDs for data network circuits are installed as required.
- Primary SPDs for site link interfaces are installed as required.
- Secondary SPDs for site link interfaces are installed as required.
- Type 3 AC power SPDs are installed at dispatch center operator positions as required.
- All RF transmission lines, including unused spares, have coaxial RF type SPDs properly installed.
- If a tower top amplifier is installed, the sample port and its control cables have SPDs installed as required.
- Tower lighting system AC power and data/alarm circuits have SPDs properly installed as required.

F.6 Equipment Installation

- Equipment spacing and aisle widths are adequate and conform to guidelines.
- Equipment is level and plumb.
- Equipment is square with respect to surrounding equipment and walls.
- Where applicable, seismic installation practices are observed.
- Cabinets and racks are secured as required.
- Cable groups of different function maintain minimum separation of at least 5 cm (2 in) as required.
- Data, network, optical fiber and RF cables meet or exceed minimum bending radius requirements.
- Plenum-rated cables are installed where required.
- Riser-rated cables are installed where required.

- _ Cables are of adequate length with no excess.
- _ Cables are properly secured at the required intervals.
- _ AC and DC power conductors installed in cable trays meet minimum installation requirements.
- _ Cables are properly identified at both ends using a standard labeling system.
- _ Abandoned cables have been removed or properly identified for future use.
- _ Fire stopping material (if required) has been properly installed.
- _ Distribution frame wiring conforms to the proper punch-down or wire wrap techniques.
- _ CAT-5/6 (or equivalent) data cables maintain the proper separation distance from AC power cables.
- _ CAT-5/6 (or equivalent) data cables do not have sharp bends.
- _ CAT-5/6 (or equivalent) cables meet all other installation requirements.
- _ Cables located below raised flooring systems are properly installed.
- _ Cables located above suspended ceilings are properly installed.
- _ Site security surveillance system (if installed) meets proper installation requirements.
- _ Utility pole equipment installations maintain proper clearances and meet installation requirements.
- _ Trash and packing material has been removed.
- _ Electrostatic discharge handling practices are observed as required.

Mobile Installation Standards and Techniques

G.1 Introduction

The information contained in this appendix has been prepared for use by persons installing mission critical two-way mobile radio equipment and associated accessories in vehicles. It has been prepared according to current engineering principles and generally accepted practices. These guidelines are intended to supplement, but not to be used in place of, detailed instructions from the manufacturers of mission critical mobile equipment. Since it is not possible to cover all possible installations of mission critical mobile equipment, Motorola Solutions, Inc. cannot be held responsible for incidental or consequential damages arising from the use of the information contained herein.

This Appendix contains information on the following topics:

- “Referenced Publications for Mobile Installation” on page G-2
- “Safety Requirements for Mobile Installation” on page G-2
- “Mobile Installer Training and Certification” on page G-3
- “Planning for Mobile Installation” on page G-4
- “Transceiver Preventative Maintenance and Inspection” on page G-5
- “Pre-Install and Post-Install Checklist” on page G-5
- “Tools for Mobile Installation” on page G-6
- “Installation of Mobile Equipment” on page G-7
- “Power Wiring for Mobile Installation” on page G-14
- “Joining Conductors for Mobile Installation” on page G-23
- “Antenna Installation and Testing” on page G-30
- “Effective Receiver Sensitivity Testing” on page G-38
- “Radio Transmit Noise Testing” on page G-41
- “Installation of Miscellaneous Equipment” on page G-43
- “Motorcycle Installations” on page G-45
- “Marine Installations” on page G-46
- “Aircraft Installations” on page G-48
- “Example of Installation Checklist” on page G-48



IMPORTANT

The information contained in this appendix is intended to supplement the equipment installation manual provided by the manufacturer. The specific equipment installation manual shall be followed.

G.2 Referenced Publications for Mobile Installation

The following publications were used in this Appendix and should be referred to for more information.

- Chrysler Corporation: Radio Communication Equipment Installation Recommendations
- FCS1362:2010: UK Code of Practice for the Installation of Mobile Radio and Related Ancillary Equipment in Land Based Vehicles
- Electronics Technicians Association International (ETA-i®): Mobile Communications & Electronics Installer
- Ford Motor Company: Mobile Radio Installation Guidelines
- General Motors: Radio Telephone / Mobile Radio Installation Guidelines
- Motorola Solutions, Inc.: APX™ Mobiles Installation Manual (part number 6878215A01)
- National Institute of Justice: Guide to Test Methods, Performance Requirements, and Installation Practices for Electronic Sirens Used on Law Enforcement Vehicles (NIJ Guide 500-00)
- SAE J1128: Surface Vehicle Standard - Low Voltage Primary Cable
- SAE J1849: Surface Vehicle Standard - Emergency Vehicle Sirens
- SAE J378: Surface Vehicle Standard - Marine Propulsion System Wiring

G.3 Safety Requirements for Mobile Installation

The following safety requirements **shall** be followed:

- To help ensure suitable and safe conditions for the installer, install work **shall** take place in a suitable dry and well illuminated location and/or facility, as practicable (see FCS1362:2010, section 2.4.1).
- The installer **shall** read all equipment instruction manuals prior to installation.
- The installer **shall** receive proper training regarding the safety hazards associated with supplemental restraint systems (airbags) and associated equipment.
- The installer **shall** receive proper training regarding the safety hazards associated with high voltage in electric and/or hybrid vehicles.



NOTE

The high voltage (up to 600 volts) cables in a hybrid vehicle are typically orange in color.

- The installer **shall** receive proper training regarding the safety hazards associated with compressed gas vehicles.
- The installer **shall** ensure the safety of the vehicle has not been compromised as a result of the mobile radio equipment installation (see FCS1362:2010).
- The installer **shall** ensure the safety of the vehicle has been maintained once work to fit the equipment has been completed (see FCS1362:2010).
- Due consideration **shall** be taken by the installer to ensure that safety is not compromised by any customer demands (see FCS1362:2010).
- Any modification to the vehicle **shall** be performed in such a way that it does not create a condition where danger is likely to be caused to the driver, passengers or other road users (see FCS1362:2010).
- Before drilling or using self drilling/tapping screws, check for vehicle system components (for example: wiring, fuel lines, brake lines, air conditioning lines, and so on) that may be damaged.
- There **shall** be no rough, sharp or protruding edges that could be impacted by the vehicle's occupants in a collision (see FCS1362:2010).

- Excess lengths of any cable ties **shall** be cut flush with its locking mechanism to avoid leaving sharp and potentially dangerous projections (FCS1362:2010).
- The controls, displays and cabling, including any microphone/handset lead of the installed equipment, **shall not** obscure nor obstruct instruments, vehicle controls or the swept area of the windscreen (windshield); neither should their operation distract or impede the driver (see FCS1362:2010).
- If the driver is the prime user of the equipment, all necessary controls should be positioned within reach of the driver but not in such a way that the driver's attention is distracted from the road or that the view of the road is obscured. See FCS1362:2010 for more information.
- The installer **shall** follow all equipment installation requirements as specified by the equipment manufacturer.
- The installer **shall** follow all installation and safety requirements published by the vehicle manufacturer related to aftermarket mobile radio equipment installations.
- Appropriate tools **shall** be used during installation, and the tools **shall** be used appropriately. See “Tools for Mobile Installation” on page G-6.
- Appropriate safety equipment (for example: safety glasses and gloves) **shall** be used during installation.
- Installer **shall** remove metallic rings and other jewelry that can come in contact with vehicle voltages.
- Appropriate hearing protection **shall** be used when running a vehicle siren.
- See FCS1362:2010 for additional safety information.

**WARNING**

Ensure adequate ventilation when running the vehicle.

**WARNING**

The installer SHALL receive proper training regarding the safety hazards associated with the following: supplemental restraint systems (airbags) and associated equipment (see FCS1362:2010), high voltage in electric and/or hybrid vehicles, and compressed gas vehicles.

**CAUTION**

Before installing any electrical equipment, check the vehicle manufacturer's user manual and/or dealership for warnings and/or recommendations.

**CAUTION**

See the specific transceiver manufacturer instruction manual (or equivalent) for information regarding Radio Frequency (RF) energy exposure safety standards and warnings.

G.4 Mobile Installer Training and Certification

Mission Critical Mobile Installers **shall** be properly trained in mobile installations, to include the following: Land Mobile Radio (LMR), basic electricity, basic electronics, vehicle mechanics, safety, and other applicable disciplines (for example: emergency lighting and sirens). A Mobile Installer **shall** be certified in mobile installations by an industry recognized certification organization. Such certifications include, but are not limited to, the following:

- Electronics Technicians Association International[®] (ETA-i[®]): Mobile Communications and Electronics Installer

- Consumer Technology Association[®] (CTA): Mobile Electronics Certified Professional (MECP)

Additional certification from the Automotive Service Excellence (ASE[®]) in Electrical/Electronic Systems (A6) is recommended.

In addition to the certifications listed above, one or both of the following certifications are recommended for marine installers:

- National Marine Electronics Association (NMEA[®]): Marine Electronics Installer
- American Boat & Yacht Council (ABYC[®]): Marine Electrical

G.5 Planning for Mobile Installation



NOTE

The following information primarily applies to projects and/or fleet installations. As applicable, the information should be used as general guidance for all installations.

Mission critical land mobile radio installations **shall** be properly planned, engineered, and documented. The final installation plan **shall** be approved by the customer. Proper mission critical installation planning should include all members of the project team as follows (as applicable):

- Customer representative with decision making authority
- Project Manager
- Project Engineer
- Project System Technologist
- Project Maintenance Technician and/or System Manager
- Project Installation Contractor

Installation planning **shall** be documented for each vehicle type (for example: Police, Fire, Public Works, and so on), for each vehicle make/model (for example: Ford Explorer, Chevy Tahoe, Dodge Charger, Ladder Truck, Engine, Aid Unit, and so on). The installation documentation **shall minimally** include the following:

- Radio transceiver mounting location
- Radio control head mounting location
- Radio microphone mounting location
- Radio speaker mounting location
- Siren speaker mounting location
- Antenna mounting location
- Radio power connection location
- Radio cable routing
- Third-party audio interface (for example: headset or PA) requirements
- Existing equipment removal and/or relocation requirements
- Power distribution and fuse locations



IMPORTANT

Ensure the antenna type and mounting location match the engineered system design. Changing the antenna type and/or mounting location without engineering approval can negatively impact the mobile radio's intended coverage footprint and/or can violate licensing limitations.

G.5.1 Vehicle Protection

The Mobile Installer **shall** exercise due care to avoid vehicle damage. Such care includes, but is not limited to, the following (see FCS1362:2010, section 2.4.3):

- Wearing nothing sharp that can scratch a vehicle or cause damage to the interior.
- Using a fender cover where applicable.
- Using drop cloths or blankets on seats.
- Avoiding putting tools in back pockets that could gouge or tear the interior of the vehicle.
- Ensuring no grease, oil, or dirt is present on hands, clothing, shoes, and so on when getting in a vehicle.

G.6 Transceiver Preventative Maintenance and Inspection

Prior to installation, the radio transceiver **shall** be tested for proper operation according to the manufacturer's recommendations and jurisdictional requirements (for example: frequency, modulation, power output, and receiver sensitivity). All applicable measurements **shall** be documented. See FCS1362:2010, section 3.3 for more information.

Inspection should include a firmware upgrade (if applicable) as needed according to the manufacturer's instructions (such as Product Service Bulletins or Technical Notifications). Inspection **shall** be made by an appropriately certified and/or licensed technician.

All test equipment used for the transceiver preventative maintenance **shall** be in known good working order and **shall** be within national and/or factory calibration standards. The test equipment calibration records **shall** be properly maintained and made available as requested.



IMPORTANT

Transceiver output power shall be set according to the manufacturer's requirements and according to the system design requirements. Some specific system designs may call for a transmitter power output of something less than the maximum rated output power. Exceeding the specific system design rated power may be in violation of licensing limitations and/or may create undesired RF interference at the system infrastructure receivers.



NOTE

Receiver sensitivity should be recorded in dBm.

G.7 Pre-Install and Post-Install Checklist

Mission critical installations **shall** be properly planned and documented as described in “Planning for Mobile Installation” on page G-4. A pre-install and post-install checklist **shall** also be included.

The pre/post-install checklist should minimally include the following (see FCS1362:2010 for example forms):

- A basic outline of the vehicle for quick indication of non-functioning lights, damage to vehicle, and equipment location.
- A checklist pass/fail should include the following: running lights, head lights, dash lights, interior lights, LED lights and bars, strobes, sirens, wig-wags, vehicle horn, reverse lights, alley lights, brake and turn signal lights, gun release, RADAR, existing radios, intercom, and so on.
- Room for additional comments.
- Radio receiver sensitivity.
- Radio effective receiver sensitivity (see “Effective Receiver Sensitivity Testing” on page G-38).
- Radio transmit power output.

- Antenna VSWR or Return Loss (see “Antenna VSWR Testing” on page G-37).
 - Forward and reflected power.
- Voltage at radio transmitter when radio is keyed.

An example form is located at the end of this Appendix in “Example of Installation Checklist” on page G-48.

G.8 Tools for Mobile Installation

All installation tools and equipment used **shall** be functional, suitably maintained, and calibrated (if required). All measurement devices and meters should be regularly checked for accuracy. If accurate electrical measurements are required, the relevant test equipment **shall** be regularly checked and calibrated against a recognized national standard according to the manufacturer's requirements.



IMPORTANT

The appropriate tool shall be used, and the tool shall be used according to the manufacturer's instructions.

The suggested installation tools and equipment include, but are not limited to, the following (see FCS1362:2010 and ETA-i[®] publication, *Mobile Communications & Electronics Installer*):

- A good quality general tool kit including screwdrivers, spanners, socket set, pliers, and so on
- Any specialist tools relative to the type of vehicle and products undergoing an installation
- Correct equipment and tools for removal of panels and trim should be used as appropriate
- VSWR meter (see “Antenna VSWR Testing” on page G-37)
- Antenna analyzer (see “Antenna VSWR Testing” on page G-37)
- Coax strippers
- RF connector ratchet crimp tool
- Wire strippers
- DC connector ratcheting crimp tool (see “Electrical Ring Terminals, Lugs, Splices, and Similar Devices” on page G-24)
- Digital Voltmeter (DVM)
- Measuring tape
- Power drill kit
- Hole saw kit
- Hole saw specifically designed for antenna mounts (typically contain a collar to prevent damage to vehicle headliner)
- Portable soldering iron
- Heat gun (required for heat shrink materials and connectors)
- Vehicle trim removal tools
- Radio removal keys
- Specialized screw or security driver bits
- Seat, panel, and fender covers to protect the vehicle during installation procedures (see “Vehicle Protection” on page G-5)
- Storage for any parts, screws or fixings (hardware) removed during installation for later reassembly

**WARNING**

DO NOT use old style test lights (test probes) on vehicles with supplemental restraint systems (airbags). Inadvertently testing the wrong wire with the test light can deploy the airbag system, possibly resulting in injury or death to the installer, and severe damage to the vehicle.

**IMPORTANT**

When crimping RF connectors (such as mini-UHF), the appropriate, manufacturer-approved, crimping tool shall be used. **DO NOT** attempt to crimp RF connectors with the wrong crimper, or other improper tool (such as pliers).

**IMPORTANT**

When crimping wire connectors and lugs, the appropriate, manufacturer-approved, crimping tool shall be used. **DO NOT** attempt to crimp connectors and lugs with the wrong crimper, or other improper tool (such as pliers).

G.9 Installation of Mobile Equipment

This section provides general guidelines for installation of mobile equipment:

- See “Safety Requirements for Mobile Installation” on page G-2.
- An equipment location **shall** be selected that provides a solid mounting point which does not interfere with the vehicle operator controls and provides adequate ventilation.

**WARNING**

DO NOT mount any transceiver, microphone, speaker, or any other item in the deployment path of the airbag system.

- The equipment and associated cables **shall not** be subject to damage during use.
- Ventilation for the equipment **shall** be maintained (see manufacturer installation instructions).
- Equipment **shall not** be located where it is subject to water damage.
- Equipment **shall not** be located where it is subject to heat damage.
- Connections to the equipment **shall** be easily accessible for maintenance purposes.
- If radio equipment is installed under the instrument panel, ensure there is no interference with proper operation of the foot controls. Mount the control head or front panel (especially the microphone cable) so that it is clear of the steering wheel and column controls and passenger airbag.
- If screws penetrate the floor, the underbody projections **shall** be sealed. This will help keep moisture out of the carpet and insulation, and will forestall rust in this area.

**WARNING**

Under no circumstances SHALL installed equipment be left loose in the vehicle. All equipment **SHALL** be securely mounted. See FCS1362:2010, section 2.5 for more information.



IMPORTANT

Local jurisdictional regulations regarding windshield (windscreen) obstruction shall be followed.

G.9.1 Mounting Systems for Mobile Electronics

Numerous third-party mounting systems are available for mounting mobile electronics in emergency vehicles. Some of the benefits of the mounting systems are as follows:

- Safe and secure mounting of mobile electronics.
- Convenient mounting of mobile electronics.
- Space saving mounting of mobile electronics.
- Fold away design for space savings and convenient servicing of the equipment.

Mounting systems are available for several applications, such as the following:

- Passenger compartment area center console (see Figure G-1)
- Trunk sliding tray (see Figure G-2)
- Trunk fold away (see Figure G-3)
- Sport Utility Vehicle (SUV) rear fold away (see Figure G-4)

Motorola Solutions, Inc. does not endorse specific mobile electronics mounting systems. Requirements for mobile electronics mounting systems are as follows:

- The mounting system **shall** be designed for the application.
- The mounting system **shall** be designed for the specific vehicle.
- The mounting system **shall** be installed according to the manufacturer's requirements.



Figure G-1 Example of Center Console Mounting System



Figure G-2 Example of Sliding Trunk Mount System (Photo Courtesy of Havis)

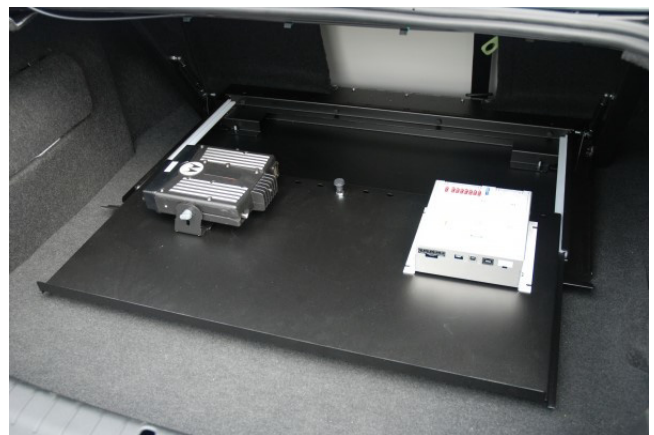

Figure G-3 Examples of Trunk Fold Away Mounting System (Photo Courtesy of Havis)



Figure G-4 Example of SUV Fold Away Mounting System (Photo Courtesy of Lund Industries)

G.9.2 Securing Hardware for Mobile Installation

Hardware to secure equipment may include the following (see FCS1362:2010, section 2.6.1.2):

- Screws or bolts with locking nuts or plain nuts with shake-proof washers are the preferred hardware for securing equipment, particularly where the equipment is heavy and/or where the equipment may be subjected to vibration.
 - This method may not always be practicable unless both sides of the holding surface are accessible.
- Rivet nuts offer a stronger solution than self drilling/tapping screws. Rivet nuts come in various types and provide a blind nut or a threaded stud. See Figure G-5 for an example.
 - Rivet nuts often require special tools for fitting.
- Self drilling/tapping screws are acceptable where a strong and secure surface is available to screw in to, and the back of the screw does not protrude into an accessible area leaving a sharp point that may cause injury or damage. See Figure G-6 for an example.
 - Be aware that self drilling/tapping screws can work loose.
 - Self drilling/tapping screws are not recommended for heavy loads.
 - Self drilling/tapping screws are not recommended for equipment mounted to the underside of a shelf (or equivalent).
- Rivets provide a more permanent mounting. Therefore, consideration **shall** be given with regards to the servicing needs of the equipment.
 - Not generally suitable for use for this reason.

Precautions **shall** be taken on all of the above to avoid the hardware working loose with vibration. The use of shake proof washers, locking nuts or flat nuts is recommended.

Corrosion resistant fastenings (for example, stainless steel nuts and bolts) should always be used in areas exposed to the elements.



Figure G-5 Example of Rivet Nut



No sharp protrusion **SHALL** be left from installed hardware. Sharp protrusions may be a potential injury hazard.



Figure G-6 Example of Self Drilling Screws

G.9.3 Routing, Protection and Securing of Conductors and Cabling

G.9.3.1 Routing of Conductors and Cabling for Mobile Installation

- Where practicable, all cables and conductors should pass under carpets and through trim or moldings in such a way as to ensure that any panels do not trap, crush or distort the cable when refitted. Use sleeving or cable protection and cable ties where required. See FCS1362:2010, section 4.3.1 for more information.
 - Cables and conductors installed under carpets **shall** be routed away from areas of normal foot traffic, as practicable.
- Cable and conductor lengths **shall** provide sufficient slack for equipment to be easily tested and maintained while still connected.
- Cables and conductors **shall** be routed and supported so they avoid the following (see FCS1362:2010, section 4.3.1.2):
 - Sharp edges
 - Continual bending
 - Stress or strain
 - Abrasion
 - Extreme temperature
 - Sharp bends
 - Creating a hazard or distraction to the occupants of the vehicle
 - Running parallel to power cables in electric/hybrid vehicles, as practicable
 - Running in parallel with equipment's antenna cables, as practicable
- Route and secure all underhood wiring away from heat and mechanical hazards, such as exhaust manifolds and moving parts (for example: steering shaft, throttle linkage, fans, and so on).
 - The use of split loom or similar is required. This is important for aesthetics, ensures against wire chafing, and protects against heat and oil damage.
 - Split loom installed in the engine space **shall** be rated for the temperature.
- Avoid routing cables and conductors near vehicle moving parts (for example: steering column, pedals, controls, and so on). See FCS1362:2010, section 4.3.1.2 for more information.
- Maintain as great a distance as practicable between mobile radio power conductors and the vehicle's electronic modules and wiring.
- If practicable, avoid running power conductors in parallel with vehicle wiring over long distances.
- Avoid routing the antenna cable (coax) in parallel with vehicle wiring over long distances, as practicable.
- Use caution when routing wires between the passenger and engine compartments to avoid chafing or pinching of wires.

G.9.3.2 Protection of Conductors and Cabling for Mobile Installation

- Cabling open to the elements **shall** be protected using split loom (or equivalent) (FCS1362:2010). See Figure G-7 for an example.
 - An example is power conductors installed in the engine area for connection to the battery.
- Cabling easily accessible within the passenger area **shall** be protected using split loom (or equivalent) (FCS1362:2010).
- Underhood cabling and conductors **shall** be protected from damage and **shall** be installed in split loom (or equivalent).
- Split loom (or equivalent) used in the engine area, or other high temperature areas, **shall** be rated for the temperature. Split loom is readily available that is rated up to 149° C (300° F).
- Split loom (or equivalent) normally exposed to UV **shall** be UV-rated.
- Grommets **shall** be used where cables pass through a firewall or bulkhead.

- Grommets **shall** be used over any exposed sharp edges.
- Any penetrations through any material **shall** use grommets for aesthetics, safety, and protection of cables.
- Penetrations through the firewall **shall** use grommets.
 - Firewall penetrations **shall** be properly sealed from dirt, fumes, and water.
 - Sealing the firewall penetration may help reduce the amount of sound transmitted from the engine area to the passenger area.



Figure G-7 Example of Split Loom



NOTE

High-temperature split loom that is rated up to 149° C (300° F) is readily available. UV-rated split loom is readily available.

G.9.3.3 Securing of Conductors and Cabling for Mobile Installation

- Cabling and conductors **shall** be secured as required to keep them in place and provide adequate strain relief.
- Cabling and conductors **shall not** be secured to movable parts under the dash, in the trunk, or in the engine compartment (for example: brake pedal, steering column, and so on)
 - Secure wires to a trunk lid arm only when mounting equipment to the trunk lid (such as antennas). Ensure there are no kinks when routing cables and leave slack where they must flex.
- Wiring **shall** be supported at intervals not greater than 45 mm (1.8 in.). See SAE J378 for more information. Wiring routed under carpets, trim or moldings is considered supported.

G.9.4 Cable Labeling for Mobile Installation

All cables **shall** be legibly labeled as to function and destination at each end, as practicable. Fuse holders **shall** be labeled as to the fuse size and associated equipment. Some labeling examples are as follows:

- APX Radio 700 MHz Antenna
- APX Radio VHF Antenna
- APX Radio GPS Antenna
- APX Radio 20A

See Figure G-8 for an example.



Figure G-8 Example of Coax Cable Labeling

G.9.5 Speaker Installation

- The speaker **shall** be installed according to the radio manufacturer instructions.
- The speaker **shall** be mounted out of the way so that it will not be kicked or knocked around by the vehicle occupants.
- The speaker **shall** be positioned to provide an unobstructed audio path to the user (see FCS1362:2010, section 4.4.3).
- The speaker **shall** be positioned to ensure any vehicle occupant is not likely to suffer discomfort from excessive audio levels (see FCS1362:2010, section 4.4.3).

G.9.6 Microphone Installation

- The microphone **shall** be installed according to the radio manufacturer instructions.
- The microphone hang-up clip **shall** be mounted within reach of the operator(s) and close enough to the control head to prevent cable strain.
- The microphone hang-up clip **shall** be mounted in a location that will prevent the microphone cable from interfering with normal vehicle operations and/or controls.



NOTE

Some radio microphone models require grounding of the microphone hang-up clip for Hang-up Box (HUB) operation to work correctly.

G.9.7 Equipment Installation in Vehicles with Airbags

Most modern vehicles are equipped with driver and passenger airbags, seat belt pretensioners and other Supplementary Restraint Systems (SRS). These safety items activate in the event of a collision. SRS components can be located in the steering wheel, under the dashboard fascia, sides of seats, front pillars and side ceiling. The vehicle instruction manual and, if necessary, vehicle manufacturer **shall** be consulted regarding the location of airbags and their deployment in the event of a collision. Care **shall** be taken during install to avoid any possibility of inadvertently triggering the airbag or SRS equipment.

Airbags will affect the equipment install location and associated cabling. The equipment and its cabling **shall not** impede the airbag deployment and operation.

If removing a seat containing side impact airbags, seatbelt pretensioners or other SRS, disconnect the vehicle battery as a safety precaution. Before unplugging seat wiring connectors, time must be allowed after the battery is disconnected to ensure any capacitors in the SRS circuitry have fully discharged. Check with the vehicle manufacturer's guidelines and/or dealer. All disturbed seat wiring **shall** be reconnected prior to restoring the vehicle battery or turning the ignition on. See FCS1362:2010, section 2.9.2.2, for more information.



WARNING

DO NOT mount any transceiver, microphone, speaker, or any other item in the deployment path of the airbag system.



WARNING

DO NOT use old style test lights (test probes) on vehicles with supplemental restraint systems (airbags). Inadvertently testing the wrong wire with the test light can deploy the airbag system, possibly resulting in injury or death to the installer, and/or severe damage to the vehicle.

G.10 Power Wiring for Mobile Installation



NOTE

The recommendations and requirements contained within this section are based on a vehicle with a 12V negative ground power system. Other vehicle power system configurations may exist. In such cases, consultation with an Installation Engineer is recommended.



IMPORTANT

A 12 volt tap must not be taken from the batteries of a vehicle that has a supply greater than 12 volts. If a vehicle has a supply greater than 12 volts, then either the equipment shall be rated for the higher voltage or a suitable regulator or converter shall be used that will provide the nominal supply voltage for which the equipment is designed. See FCS1362:2010, section 4.6.6 for more information.

- The power cable supplied by the radio manufacturer **shall** be used, where practicable.
- If the power cable must be extended, total voltage drop **shall** be considered. See “Power Conductors for Mobile Installation” on page G-17.
- Transceiver (+) power (red) connections should be made to one of the following:
 - Directly to the battery, using appropriate hardware. See Figure G-9.
 - To an adequate power distribution center. Consult the vehicle manual and/or dealership to determine the power distribution center ampacity rating.
 - To the positive jump-start post, if present. See Figure G-10.
 - To the vehicle power disconnect switch, if applicable.
 - To the vehicle filtered battery distribution center (available on some emergency vehicles for the purpose of supplying power to the mission critical systems).
- The power conductor (+) **shall** be appropriately fused as close to the source as practicable. A weatherproof fuse holder is recommended.

- Transceiver (-) ground (black) should be connected to a convenient solid chassis ground point as close as practicable to the point where the battery-to-body connection is made (FCS1362:2010).
 - Such as a factory installed negative jump-start post. See Figure G-11.
 - **Do not** connect the ground (black) conductor directly to the battery's negative terminal.
- **Do not** fuse the ground (-) lead. If the ground-side fuse were to open, the entire supply current would be conducted by the coax shield. This could cause the coax to overheat with possible resulting damage.
- The radio power conductor (+) and ground (-) should be run together along their length as practicable in order to reduce induced noise (FCS1362:2010). The conductors can be twisted together for increased immunity to induced noise. See Figure G-12.
- Splices in the power cable **shall** be avoided, where practicable.
 - If required, splices **shall** be limited to one per power conductor, as practicable. If more than one splice is required, suitable solder splices (such as soldered compression butt splice) **shall** be used. See “Joining Conductors for Mobile Installation” on page G-23.
 - If required, splices **shall** be made at an easily accessible and conspicuous location.
 - Splices **shall not** be made in areas susceptible to physical damage and/or moisture intrusion.
- Cigarette lighter or “Power Point” receptacles **shall not** be used as power sources for mission critical equipment.
- For switched power sources such as ignition and accessory, avoid tapping into sources such as cigarette lighters and AM/FM radio. Go directly to the ignition harness or fuse block and add an in-line fuse holder with the proper size fuse for the equipment.

CAUTION

Do not fuse the transceiver ground (negative) conductor. If the ground-side fuse were to open, the entire supply current would be conducted by the coax shield or other alternate current return path. This could cause the coax to overheat with possible resulting damage.

CAUTION

Do not connect the ground (black) conductor directly to the battery's negative terminal.

IMPORTANT

Except under engineering supervision, DO NOT reuse existing radio power conductors or cables.

NOTE

Some vehicles (for example: large buses, tractor-trailers, Fire Apparatus, and so on) may not have a source of clean DC power. In these applications, a DC Power Filter may be required to filter out noise. Consultation with a technician and/or Installation Engineer may be required. See Figure G-13 for a DC Power Filter example.

NOTE

In some heavy commercial vehicles, and in vehicles with tilting cabs where the cab may be isolated from the chassis by rubber mountings, a ground point is typically provided by the vehicle manufacturer within the cab to provide battery to cab grounding. Generally this is located within the main fuse box. It is recommended that this point be used for installations in this instance. See FCS1362:2010 for more information.

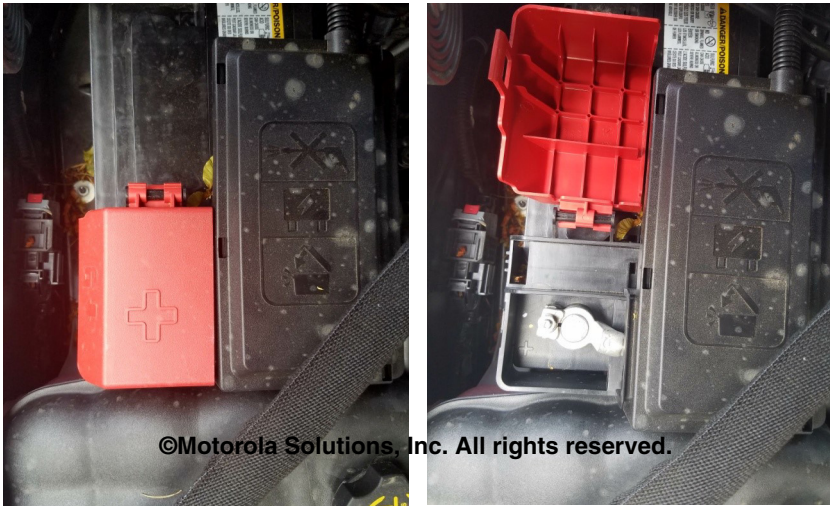

Figure G-9 Example of Vehicle Battery with External Terminal

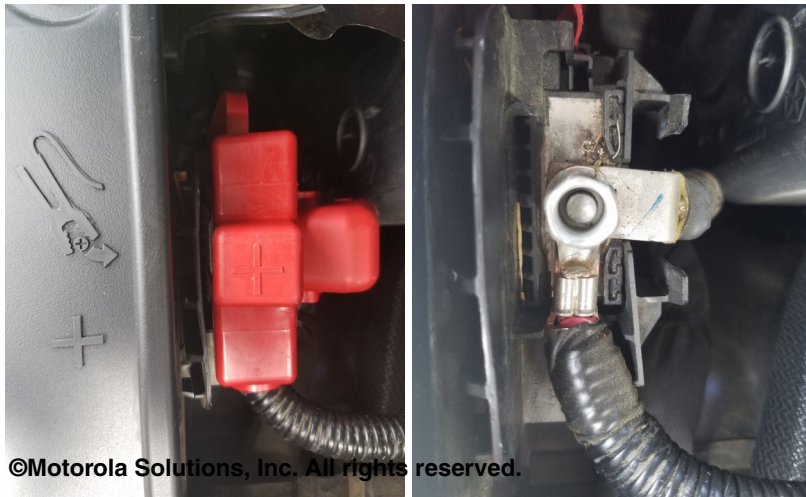

Figure G-10 Example of Vehicle Positive Jump Start Post

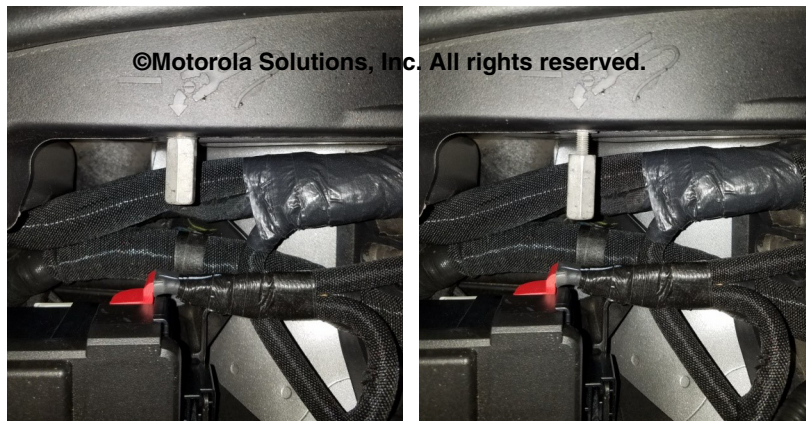

Figure G-11 Example of Vehicle Negative Jump Start Post

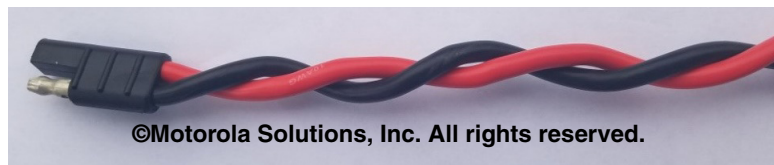

Figure G-12 Example of Power Conductors Twisted Together for Increased Noise Immunity



Figure G-13 Example of DC Power Filter (Motorola Solutions Part Number TLN5277)



IMPORTANT

Where a 24 volt or higher supply is used on an isolated return vehicle system, a suitable DC converter, providing DC isolation (no DC continuity between battery and output) shall be used. See FCS1362:2010, section 4.6.7.1, for more information.

G.10.1 Power Conductors for Mobile Installation

Power conductors used in mission critical mobile installations **shall** be appropriate for the application. The conductors **shall** be resistant to the following (as applicable): abrasion, battery acid, diesel fuel, gasoline, moisture, oil, sunlight, and so on (see SAE J1128).

Power conductors used in mission critical applications **shall** be rated as appropriate for the application:

- Conductors used in automotive applications **shall** be stranded automotive grade.
- Conductors used in marine applications **shall** be stranded marine grade.
 - Marine grade conductors are commonly tinned to provide additional corrosion resistance.
 - Conductors used in marine applications **shall** be UL 1426 (or equivalent) listed as required by jurisdictional regulations.

There are two main categories of automotive conductor:

- Polyvinyl chloride (PVC), which has three main types, as follows:
 - General Purpose Thermoplastic Insulated (GPT): Used for general circuit wiring. Rated to 80 °C (176° F).
 - Thin Wall Thermoplastic Insulated (TWP): Lead-free thin wall wire. Rated to 105 °C (221° F).
 - Heavy Duty Thermoplastic Insulated (HDT): Heavy wall wiring. Rated to 80 °C (176° F).
- Cross-Linked (X), which has three main types, as follows:
 - General Purpose Cross Linked Polyolefin Insulated (GXL): Thin wall, most common type, works with most standard automotive connectors. Rated to 125 °C (257° F).
 - Special Purpose Cross Linked Polyolefin Insulated (SXL): Standard wall. Rated to 125 °C (257° F).

- Thin Wall Cross Linked Polyolefin Insulated (TXL): Extra thin wall, best for applications that require minimal size and weight. Rated to 125 °C (257° F).

G.10.1.1 Selecting Conductor Size

The power cable supplied by the equipment manufacturer **shall** be used, where practicable. If a power cable must be extended for a specific installation (such as in a large fire apparatus), the conductor used **shall** be the appropriate type and **shall** be appropriately sized for an acceptable voltage drop (see “Equipment Power Conductors Voltage Drop” on page G-18).

If the power conductor being extended must be increased in size in order to maintain an acceptable voltage drop (see “Equipment Power Conductors Voltage Drop” on page G-18), the splice **shall** be made as close to the radio unit as practicable. The splice **shall** be made at an easily accessible and conspicuous location. The extended and/or larger conductor **shall** be fused the same as the original power cable, according to the equipment manufacturer requirements. The fuse holder **shall** be clearly labeled as to the fuse size and protected equipment (for example: APX radio, 20A).

G.10.1.2 Equipment Power Conductors Voltage Drop

Motorola Solutions recommends a maximum voltage drop of 5% from the battery (source) to the mission critical equipment (at full load). The total length of the positive and negative conductors **shall** be considered. If the specific equipment manufacturer requirements are less than 5% voltage drop, the manufacturer requirements **shall** be followed.



NOTE

A voltage drop of 5% in the power supply conductors from a 13.8 V source would result in a delivered voltage to the load (equipment) of 13.11 V at full load current. Voltage drop calculations other than 5% may require the assistance of an engineer. An online calculator can be found at the following site: <http://www.calculator.net/voltage-drop-calculator.html>.

Table G-1 provides the minimum copper conductor size for a given current and total power conductor length (positive and negative) that will provide 5% or less voltage drop to the load.

Table G-1 MINIMUM COPPER CONDUCTOR SIZE (AWG) FOR GIVEN CURRENT AND LENGTH

Current Flow in Amps													
	5A	10A	15A	20A	25A	30A	40A	50A	60A	70A	80A	90A	100A
10 ft	18	18	16	14	14	12	12	10	10	8	8	8	8
15 ft	18	16	14	12	12	10	10	8	8	8	6	6	6
20 ft	18	14	12	12	10	10	8	8	6	6	6	4	4
25 ft	16	14	12	10	10	8	8	6	6	6	4	4	4
30 ft	16	12	10	10	8	8	6	6	4	4	4	4	2
40 ft	14	12	10	8	8	6	6	4	4	2	2	2	2
50 ft	14	10	8	8	6	6	4	4	2	2	2	1	1
60 ft	12	10	8	6	6	4	4	2	2	2	1	1	1/0
70 ft	12	8	8	6	6	4	2	2	2	1	1/0	1/0	1/0

NOTE: Recommended conductor sizes are in American Wire Gauge (AWG). Maximum voltage drop of 5% is based on a 13.8 V supply.

Table G-1 MINIMUM COPPER CONDUCTOR SIZE (AWG) FOR GIVEN CURRENT AND LENGTH (CONTINUED)

Current Flow in Amps													
	5A	10A	15A	20A	25A	30A	40A	50A	60A	70A	80A	90A	100A
80 ft	12	8	6	6	4	4	2	2	1	1/0	1/0	2/0	2/0
90 ft	10	8	6	4	4	4	2	1	1	1/0	2/0	2/0	3/0
100 ft	10	8	6	4	4	2	2	1	1/0	1/0	2/0	3/0	3/0

NOTE: Recommended conductor sizes are in American Wire Gauge (AWG). Maximum voltage drop of 5% is based on a 13.8 V supply.

**NOTE**

Distance and/or current values exceeding those listed in the tables in this Appendix may require the assistance of an engineer.

G.10.1.3 Power Distribution Unit

Where a Power Distribution Unit (PDU) (see Figure G-14) is installed in an area of the vehicle, such as in the trunk or passenger compartment equipment console, the conductor supplying the PDU **shall** be sized for an acceptable voltage drop based on 125% of the expected maximum current draw. See “Power Distribution Unit Power Conductor” on page G-21 for PDU conductor voltage drop information.

**NOTE**

Consultation with an engineer may be required to determine the maximum current draw of the connected equipment. The calculated maximum current draw should be based on the actual current draw of the connected equipment, not their associated fuse sizes.

©Motorola Solutions, Inc. All rights reserved.

**Figure G-14** Example of Power Distribution Unit**IMPORTANT**

It is recommended to use a PDU for radio equipment and other sensitive electronics, and a separate PDU for other types of emergency equipment (for example: light-bars, flashers, gun locks, strobe lights, and so on).

When selecting the conductor size, perform the following actions:

1. Determine the maximum expected current draw from the PDU, based on the connected equipment. The PDU maximum current rating, or future equipment connections should be considered.
2. Multiply the current value in Step 1 by 1.25.
3. Determine conductor length.
4. Select the minimum conductor size according to “Power Distribution Unit Power Conductor” on page G-21, based on the current value calculated in Step 2, and the conductor length for the given installation in Step 3.
5. Determine the temperature rating of the proposed conductor.
6. Determine if the conductor will be installed, partially or completely, in the engine space.
7. Using “Power Conductor Ampacity and Fuse Rating” on page G-22 and Table G-3, determine if the conductor size selected in Step 4 meets the allowable amperage for the selected conductor (temperature rating) and installation location (inside or outside engine spaces).
8. If the conductor allowable amperage does not permit the current value from Step 2, increase the conductor size and/or conductor temperature rating as required.
9. Fuse the conductor according to the current value in Step 2.

Example 1

1. PDU is rated for 80A.
2. $80A * 1.25 = 100A$.
3. Conductor length is 50 feet.
4. According to Table G-2, the minimum conductor size for the given current in Step 2 (100A), and conductor length in Step 3 (50 ft) is #2/0 AWG.
5. Proposed conductor has a temperature rating of 80 °C (176° F).
6. A portion of the conductor will be installed in the engine space. Therefore, the “Inside Engine Spaces” column of Table G-3 will be used.
7. Table G-3 permits 222A for the proposed #2/0 AWG conductor.
8. In this example, no conductor size and/or temperature rating increase is required since the current in Step 2 (100A) does not exceed the allowable amperage permitted in Step 7 (222A).
9. The conductor is fused at the Step 2 current value (100A) as close to the source as practicable.

Example 2

1. PDU is rated for 80A.
2. $80A * 1.25 = 100A$.
3. Conductor length is 10 feet.
4. According to Table G-2, the minimum conductor size for the given current in Step 2 (100A), and conductor length in Step 3 (10 ft) is #6 AWG.

5. Proposed conductor has a temperature rating of 80 °C (176° F).
6. A portion of the conductor will be installed in the engine space. Therefore, the “Inside Engine Spaces” column of Table G-3 will be used.
7. Table G-3 permits 78A for the proposed #6 AWG conductor.
8. In this example, the current from Step 2 (100A) exceeds the allowable amperage permitted in Step 7 (78A). Therefore, the conductor size and/or temperature rating must be increased using one of the following options (see Table G-3):
 - 105 °C (or higher) rated #6 AWG
 - 80 °C (or higher) rated #4 AWG
9. The conductor is fused at the Step 2 current value (100A) as close to the source as practicable.

G.10.1.4 Power Distribution Unit Power Conductor

Motorola Solutions recommends a maximum voltage drop of 3% from the battery (source) to the Power Distribution Unit (PDU), at full load (see American Boat and Yacht Council standards for more information). The total length of the positive and negative conductors **shall** be considered.

When using a power distribution system, the use of a distributed ground bar is recommended. The conductor feeding the ground bar (-) should be sized the same as the conductor feeding the PDU (+).



NOTE

A voltage drop of 3% in the PDU power supply conductors from a 13.8 V source would result in a delivered voltage to the PDU of 13.39 V at full load current. Voltage drop calculations other than 3% may require the assistance of an engineer. An online calculator can be found at the following site: <http://www.calculator.net/voltage-drop-calculator.html>.

Table G-2 provides the minimum copper conductor size for a given current and total power conductor length (positive and negative) that will provide 3% or less voltage drop to the PDU.

Table G-2 MINIMUM COPPER CONDUCTOR SIZE (AWG) FOR GIVEN CURRENT AND LENGTH

Current Flow in Amps													
	5A	10A	15A	20A	25A	30A	40A	50A	60A	70A	80A	90A	100A
10 ft	18	16	14	13	12	11	10	9	8	7	7	6	6
15 ft	17	14	12	11	10	9	8	7	6	6	5	5	4
20 ft	16	13	11	10	9	8	7	6	5	4	4	3	3
25 ft	15	12	10	9	8	7	6	5	4	3	3	2	2
30 ft	14	11	9	8	7	6	5	4	3	3	2	2	1
40 ft	13	10	8	7	6	5	4	3	2	1	1	1/0	1/0
50 ft	12	9	7	6	5	4	3	2	1	1/0	1/0	2/0	2/0

NOTE: Recommended conductor sizes are in American Wire Gauge (AWG). Maximum voltage drop of 3% is based on a 13.8 V supply.

Table G-2 MINIMUM COPPER CONDUCTOR SIZE (AWG) FOR GIVEN CURRENT AND LENGTH (CONTINUED)

Current Flow in Amps													
	5A	10A	15A	20A	25A	30A	40A	50A	60A	70A	80A	90A	100A
60 ft	11	8	6	5	4	3	2	1	1/0	1/0	2/0	2/0	3/0
70 ft	10	7	6	4	3	3	1	1/0	1/0	2/0	3/0	3/0	4/0
80 ft	10	7	5	4	3	2	1	1/0	2/0	3/0	3/0	4/0	4/0
90 ft	9	6	5	3	2	2	1/0	2/0	2/0	3/0	4/0	4/0	300 kcmil
100 ft	9	6	4	3	2	1	1/0	2/0	3/0	4/0	4/0	300 kcmil	350 kcmil

NOTE: Recommended conductor sizes are in American Wire Gauge (AWG). Maximum voltage drop of 3% is based on a 13.8 V supply.

**NOTE**

Distance and/or current values exceeding those listed in the tables in this Appendix may require the assistance of an engineer.

G.10.1.5 Power Conductor Ampacity and Fuse Rating

Conductor ampacity is commonly defined as the maximum amount of electric current a conductor can carry before sustaining immediate or progressive deterioration. Also described as the current-carrying capacity a conductor can continuously carry while remaining within its temperature rating. Conductor ampacity primarily depends on its insulation temperature rating.

The temperature rating of power conductors **shall** be considered and properly selected for the application. Motorola Solutions recommends a minimum conductor temperature rating of 80 °C (176° F).

**NOTE**

Automotive rated conductors are readily available with a minimum temperature rating of 80 °C (176° F).

Power conductors **shall** be properly fused according to the conductor ampacity (current carrying capacity) rating. Table G-3 provides the maximum allowable amperage for conductors under 50 V, based on the temperature rating of the conductor and the installation location (inside or outside engine spaces). Power conductors **shall** be fused no greater than that allowed in Table G-3.

**NOTE**

Conductors installed inside engine spaces have a lower ampacity due to the increased ambient temperature. Conductor insulation temperature must not exceed its rating. Ambient temperature and conductor temperature increase due to current flow (I^2R) are both conductor insulation temperature factors. Table G-3 considers ambient temperature and current flow.

Table G-3 MAXIMUM ALLOWABLE AMPERAGE OF CONDUCTORS UNDER 50 VOLTS

Temperature Rating of Conductor Insulation										
Conductor Size		80 °C (176° F)		90 °C (194° F)		105 °C (221° F)		125 °C (257° F)		200 °C (392° F)
English (AWG)	Metric (mm ²)	Outside Engine Spaces	Inside Engine Spaces	Outside Engine Spaces	Inside Engine Spaces	Outside Engine Spaces	Inside Engine Spaces	Outside Engine Spaces	Inside Engine Spaces	Outside or Inside Engine Spaces
18	(0.8)	15	11.7	20	16.4	20	17.0	25	22.3	25
16	(1)	20	15.6	25	20.5	25	21.3	30	25.7	35
14	(2)	25	19.5	30	24.6	35	29.8	40	35.6	45
12	(3)	35	27.3	40	32.8	45	39.3	50	44.5	55
10	(5)	50	39.0	55	45.1	60	51.0	70	62.3	70
8	(8)	70	54.6	70	57.4	80	68.0	90	80.1	100
6	(13)	100	78.0	100	82.0	120	102	125	111	135
4	(19)	130	101	135	110	160	136	170	151	180
2	(32)	175	138	180	147	210	178	225	200	240
1	(40)	210	163	210	172	245	208	265	235	280
0	(50)	245	191	245	200	285	242	305	271	325
00	(62)	285	222	285	233	330	280	355	316	370
000	(81)	330	257	330	270	385	327	410	384	430
0000	(103)	385	300	385	315	445	378	475	422	510

G.11 Joining Conductors for Mobile Installation

Suitable methods of joining conductors include the following (see FCS1362:2010 and “Electrical Ring Terminals, Lugs, Splices, and Similar Devices” on page G-24 for more information):

Soldering

- Soldering typically requires more skill than crimping, therefore it is subject to more mistakes.
- Soldered joints **shall** employ a mechanical aspect to give strength to the joint prior to soldering. Such as the following:
 - Non-insulated crimp butt connector
 - Wrapping one conductor around the other (see “Conductor Tapping and Soldering” on page G-27 and Figure G-23)
- Solder the conductors using industry accepted techniques. See Figure G-24 for an example of a completed solder connection.
- The soldered joint **shall** be sealed with one of the following:

- Heat shrink tubing.
- Self amalgamating tape. See “Conductor Tapping and Soldering” on page G-27 and “Electrical Tape and Heat Shrink Tubing” on page G-28 for more information.
- Insulation tape, which is then wrapped in a cloth tape. This will keep the insulation tape in place over time but still provide excellent insulation. See FCS1362:2010 for more information.
- See “Electrical Tape and Heat Shrink Tubing” on page G-28 for more information.



IMPORTANT

Soldering, particularly with gas powered irons, may not be appropriate in certain environments. Caution shall be taken where a gas soldering iron has a hot air vent, which could easily cause damage to the insulation of other cables or the environment around the area of use. See FCS1362:2010 for more information.

Crimped (Butt) Connectors

- Crimped butt connectors are an acceptable method provided the correct size connector is chosen and the proper ratchet tool is used.
- Crimped butt connectors are only suitable for use inside a vehicle where the connector is not exposed to the elements. Crimped butt connectors **shall not** be used under vehicle carpet that is exposed to normal foot traffic.
- See “Electrical Ring Terminals, Lugs, Splices, and Similar Devices” on page G-24 for more information.

Heat Shrink Butt Connectors

- Heat shrink butt connectors come in two types, crimp and solder.
- They have a heat shrink outer casing, making them acceptable in areas where the connector may be exposed to the elements.
- Crimp versions **shall** be crimped before the outer casing is shrunk.
 - The correct crimp tool **shall** be used.
 - See “Electrical Ring Terminals, Lugs, Splices, and Similar Devices” on page G-24 for more information.
- Solder versions are self-contained with pre-fluxed solder within a transparent heat shrinkable tube.
 - Can be completed with just a heat gun.
 - Combine a soldered, strain relieved, encapsulated termination for weatherproofing and can be used on sensitive low-temperature wires such as PVC.
 - See Figure G-19 for an example.

G.11.1 Electrical Ring Terminals, Lugs, Splices, and Similar Devices

Electrical ring terminals, lugs, splices, and similar devices (electrical connection devices) used in mission critical applications **shall** be appropriate for the application (see Figure G-15).



Figure G-15 Examples of Electrical Connection Devices

The requirements and recommendations for electrical connection devices are as follows:

- Electrical connection devices **shall** be UL listed (or equivalent), Canadian Standards Association (CSA) certified, or have the CE (European Conformity) marking.
- Electrical connection devices **shall** be suitable for the type of conductor:
 - Solid
 - Stranded
- Electrical connection devices **shall** be suitable for the size of conductor.
- Electrical connection devices **shall** be suitable for use in industrial, automotive, and other high-vibration electrical applications (see product documentation).
- Consumer-grade electrical connection devices **shall not** be used.
- Electrical conductors **shall** be prepared in such a way that no bare wire is exposed once the electrical connection device is attached.
- Electrical conductors **shall not** be damaged during preparation or stripping of insulation. Care **shall** be taken to ensure all conductor strands are intact and undamaged.
- Plastic auto electrical snap lock splicing connectors that cut into the cable's insulation (the insulation displacement connector) should not be used as a connection method (FCS1362:2010, section 2.6.1.4). See Figure G-16 for examples.



Figure G-16 Examples of Unacceptable Insulation Displacement Connectors

- Electrical connection devices used in marine applications **shall** be suitable for marine applications. Marine application devices typically have the following characteristics:
 - Constructed from tinned-copper for improved corrosion resistance.
 - Contain adhesive lined heat shrink insulator to seal connection from vibration and to provide improved strain relief.
 - See Figure G-17 for examples.



Figure G-17 Examples of Marine-Grade Electrical Connection Devices

- Butt-connectors exposed to the elements (for example: installed under the hood, or installed under the vehicle carpet and exposed to foot traffic) **shall** be heat shrink type butt connectors (or marine grade). See Figure G-18 and Figure G-19 for examples.



©Motorola Solutions, Inc. All rights reserved.

Figure G-18 Example of Heat Shrink Crimped Butt Connector



©Motorola Solutions, Inc. All rights reserved.

Figure G-19 Example of Heat Shrink Solder Butt Connector

- Only manufacturer-approved crimping devices **shall** be used (see product documentation).
- Ring lugs should be used where practicable as opposed to spade lugs. Ring lugs have greater contact area and are more secure.
- Electrical connection devices should have a brazed seam for protection of the barrel from splitting during the crimping process. Proper crimping techniques **shall** be used to help prevent splitting of the barrel.
 - The connection device **shall** be inserted into the tool so the seam is within the round portion of the crimping tool (as applicable).
 - See Figure G-20 for an example.
 - See the specific crimper instructions.



©Motorola Solutions, Inc. All rights reserved.

Figure G-20 Example of Proper Crimping Technique

- The crimping tool used **shall** be the approved tool by the electrical connection device manufacturer (see electrical connection device instructions).
 - A Controlled Cycle (ratcheting) crimping tool is recommended for consistent quality crimps. See Figure G-21 for an example of a Controlled Cycle crimping tool.



Figure G-21 Example of Controlled Cycle (Ratcheting) Crimper

G.11.2 Bonding Requirements for Mobile Installation

The following requirements apply when attaching a lug to a bonding surface, such as when attaching an equipment ground (-) conductor to the vehicle chassis:

- Paint, enamel, lacquer and other non-conductive coatings **shall** be removed from surface areas where connections are made to ensure good electrical continuity.
- Bonding surfaces **shall** be cleaned to remove dirt, corrosion and oxidized material on the connection surface area.
- The use of a piloted bonding brush is recommended for cleaning the bonding surface. See Figure G-22 for an example of a piloted bonding brush.
- After bonding to a factory painted surface, the area **shall** be thoroughly cleaned and coated with an approved corrosion inhibiting paint (or equivalent). See FCS1362:2010, section 2.11.3 for more information.



IMPORTANT

DO NOT install a washer of any kind between a lug and the bonding surface.



NOTE

Use of a star washer does not alleviate the requirement to remove non-conductive coatings from attachment surfaces. Star washers should only be used as a lock washer.



Figure G-22 Example of Piloted Bonding Brush

G.11.3 Conductor Tapping and Soldering

Conductors must sometimes be tapped into a vehicle wiring system conductor. Such applications may be one or more of the following:

- Radio ignition sense conductors are required and an ignition switched power point is not readily available at the vehicle fuse box or other location.
- Vehicle horn conductor is required for radio accessory features, such as audible alert and/or siren features (“horn ring”).
- Vehicle lights conductor is required for radio accessory features, such as visual alert.

Since plastic auto electrical snap lock splicing connectors (insulation displacement connectors) are not recommended (see “Electrical Ring Terminals, Lugs, Splices, and Similar Devices” on page G-24), soldering may be required (see FCS1362:2010).

Soldered joints **shall** employ a mechanical aspect to give strength to the joint prior to soldering. For example, wrapping one conductor around the other (see Figure G-23). Motorola Solutions recommends wrapping the tap conductor (yellow in Figure G-23) around the tapped conductor (red in Figure G-23) approximately three times.



Figure G-23 Example of Wrapping One Conductor Around the Other Prior to Soldering

Soldering **shall** be performed only by properly trained personnel. The following general process **shall** be followed (see FCS1362:2010):

1. Cut approximately 20 mm (0.8 in) of insulation from the conductor being tapped into (red in Figure G-23).
2. Tin the conductor being tapped into (red in Figure G-23)
3. Twist the tap conductor (yellow in Figure G-23) around the exposed tapped conductor (red in Figure G-23) approximately three times.
4. Solder the conductors using industry accepted techniques. See Figure G-24 for an example of a completed solder connection.
5. Clean the joint as needed and remove any sharp elements such as protruding wires.
6. Seal the joint with self-amalgamating tape, or insulation tape that is then wrapped in a cloth tape. Insulation tape is prone to losing its adhesive properties over time and through exposure to moisture and varying temperatures. See “Electrical Tape and Heat Shrink Tubing” on page G-28 and Figure G-26.



Figure G-24 Example of Completed Solder Connection

G.11.4 Electrical Tape and Heat Shrink Tubing

Electrical tape and similar products used **shall** be appropriate for the application. The general requirements and recommendations are as follows:

- Electrical tape **shall** be listed (for example, CSA or UL).
- Electrical tape **shall** be commercial-grade, professional-grade, or heavy duty-grade as defined by the manufacturer.
 - Consumer-grade or economy-grade tape **shall not** be used.
- Heat shrink tubing **shall** be listed (for example, CSA or UL). See Figure G-25 for examples.



Figure G-25 Examples of Heat Shrink Tubing



NOTE

Heat shrink tubing is readily available in many colors, sizes, and shrinking ratios.

- Heat shrink tubing is the preferred method of insulating as it provides excellent all around insulation and does not react badly to moisture or typical seasonal temperature changes (FCS1362:2010).
 - Non-adhesive heat shrink tubing can be used inside a vehicle.
 - An adhesive lined heat shrink tubing **shall** be used if the joint is exposed to the elements and/or in marine applications.
- The appropriate manufacturer-recommended heat source **shall** be used to shrink the tubing.
 - Typically a heat gun is used for this purpose.
 - An open flame is not recommended.
- Self-amalgamating (self-bonding or self-fusing) tape **shall** be designed for use as an electrical tape as defined by the manufacturer.
- Soldered joints on tapped conductors **shall** be insulated with a self-amalgamating tape, or insulation tape that is then wrapped in a cloth tape. See “Conductor Tapping and Soldering” on page G-27 and Figure G-26.



©Motorola Solutions, Inc. All rights reserved.

Figure G-26 Example of Self-Amalgamating Tape

G.12 Antenna Installation and Testing

This section provides antenna installation requirements and guidelines. Instructions provided with the transceiver and antenna manufacturer **shall** be followed.

G.12.1 Coaxial Cable (Coax)

- The coax supplied by the radio manufacturer **shall** be used, where practicable.
- The coax used **shall** be commercial grade and designed for mission critical applications.
 - A minimum 95% shield is recommended.
 - Low loss as required by the frequency in use (consult with the System Engineer).
- Stranded center conductor coax is recommended.
 - Solid center conductor coax should not be used in mobile installations. Solid center conductors are susceptible to breakage due to repeated flexing in mobile applications.
- The coax from the radio to the antenna **shall** be free of splices and/or extensions. The appropriate length cable **shall** be used for the application.
- The appropriate connector **shall** be used for the type of coax used (see manufacturer's specifications).
- Marine grade coax **shall** be used in marine installations.
 - Marine grade coax is designed for UV and salt environments.
 - Marine grade coax center conductor and outer shield are tinned for corrosion resistance.
 - Marine grade coax typically has a white outer jacket.



IMPORTANT

Except under engineering supervision, DO NOT reuse existing coaxial cables.

G.12.2 Antenna Installation



NOTE

The information in this section is primarily taken from the *APX Mobiles Installation Manual*.



IMPORTANT

Ensure the installed antenna type and mounting location matches the engineered system design. Changing the antenna type and/or mounting location without engineering approval can negatively impact the mobile radio's ability to transmit and/or receive on the intended system.



IMPORTANT

Antennas shall be tuned according to manufacturer instructions, as applicable.

Motorola Solutions recommends the following sequence to ensure proper antenna system installation:

1. **External installation:** Check the requirements of the antenna supplier and install the vehicle antenna external to a metal body vehicle in accordance with those requirements.

2. **Roof top:** For optimum performance and compliance with RF Energy Safety standards, mount the antenna in the center area of the roof.
3. **Trunk lid:** On some vehicles with clearly defined, flat trunk lids, the antennas of some radio models (see restrictions below) can also be mounted on the center area of the trunk lid. For vehicles without clearly defined, flat trunk lids (such as hatchback autos, sports utility vehicles, and pickup trucks), mount the antenna in the center area of the roof.
4. Before installing an antenna on the trunk lid:
 - Be sure that the distance from the antenna location on the trunk lid will be at least 85 cm (33 in.) from the front surface of the rear seat-back to assure compliance with RF Energy Safety standards.
 - Ensure that the trunk lid is grounded by connecting grounding straps between the trunk lid and the vehicle chassis, as required.
5. Mounting restrictions for certain radio models.
 - For all VHF and UHF models, the 1/4 wave antenna should be mounted only in the center area of the roof, not on the trunk lid, to assure compliance with RF Energy Safety standards.
6. Ensure that the antenna cable can be easily routed to the radio. Route the antenna cable as far away as possible from any vehicle electronic control units and associated wiring.
7. Check the antenna location for any electrical interference.
8. Ensure that any transmitting radio antennas on this vehicle are separated from each other by at least 0.9 m (3 ft.). See Figure G-27.
9. The minimum distance between the antenna and the radio/accessories should be at least 91.44 cm (3 ft.).
10. The minimum distance between the antenna and the fuel filler cap **shall** be 30 cm (12 in.), as practicable (FCS1362:2010, section 4.2.3.2).

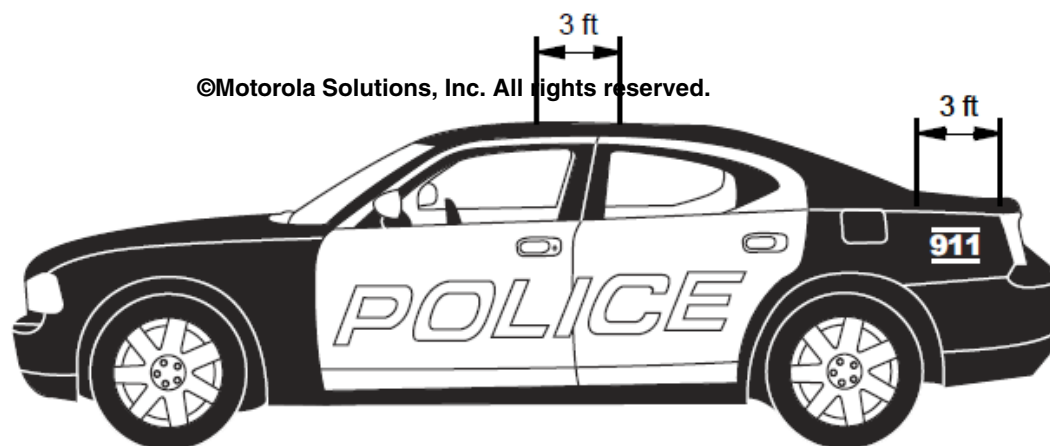

Figure G-27 Separation of Multiple Antennas



IMPORTANT

Except under engineering supervision, DO NOT reuse existing antennas and/or coaxial cables.

NOTE

Any two metal pieces rubbing against each other (such as seat springs, shift levers, trunk and hood lids, exhaust pipes, and so on) in close proximity to the antenna can cause severe receiver interference.

NOTE

See FCS1362:2010, Appendix E for example antenna radiation patterns for common antenna installation locations.

G.12.3 Antenna Installations on Non-Metallic Surfaces

Many emergency vehicles, motorcycles, and marine vessels contain fiberglass or other non-metallic body parts (including the roof). Antennas mounted in these locations require special consideration to ensure proper antenna performance. Options for installations on non-metallic surfaces include (but are not limited to) the following:

- Antenna specifically designed for no ground plane installations.
- Foil ground plane tape designed specifically for mobile installations (see Figure G-28).
 - The foil tape is typically self-adhesive for ease of installation.
 - The foil tape is effective for uneven surfaces.
 - The foil tape is installed on the underside of the mounting surface (for example, a fiberglass roof).
 - The tape should be arranged so that at least four strips are equally spaced around a common intersecting point, as practicable. The intersecting point is the antenna mounting hole. See Figure G-29 for an example.
 - The coax mount grounding hardware **shall** make good electrical contact with the sections of foil tape.
 - The minimum length of the foil tape from the center intersection point to each end (radius of circle) should be equal to the $\frac{1}{4}$ wavelength of the desired frequency. See Table G-4 and the graph in Figure G-31 for example lengths at given frequencies.
- Metallic ground plate designed for mobile installations.
 - The ground plate is mounted in a similar fashion as described above for foil tape.
 - Metallic ground plate is ideal for smooth and even surfaces.
 - The radius of the plate should be sized the same as described for foil tape. See Table G-4 and the graph in Figure G-31.
 - See Figure G-30 for an example of ground plate.
- Other engineered ground plane.



©Motorola Solutions, Inc. All rights reserved.

Figure G-28 Example of Foil Ground Plane Tape

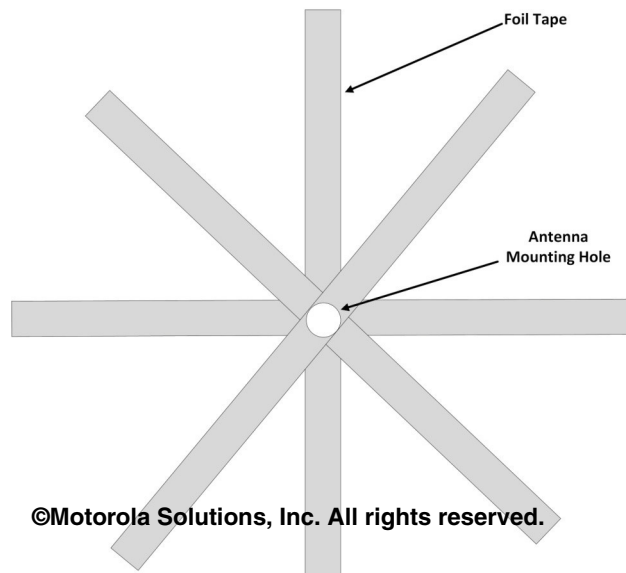

Figure G-29 Example of Minimum Recommended Foil Tape Installation Pattern



Figure G-30 Example of Metallic Ground Plane Plate

Table G-4 FREQUENCY VERSUS $\frac{1}{4}$ WAVELENGTH

Frequency	Approximate $\frac{1}{4}$ Wavelength
27 MHz	2.8 m (109 in.)
50 MHz	1.5 m (59 in.)
100 MHz	0.75 m (29.5 in.)
150 MHz	0.5 m (19.7 in.)
170 MHz	0.44 m (17.4 in.)
430 MHz	0.174 m (6.9 in.)
450 MHz	0.167 m (6.6 in.)
700 MHz	0.107 m (4.2 in.)
800 MHz	0.094 m (3.7 in.)
900 MHz	0.083 m (3.3 in.)

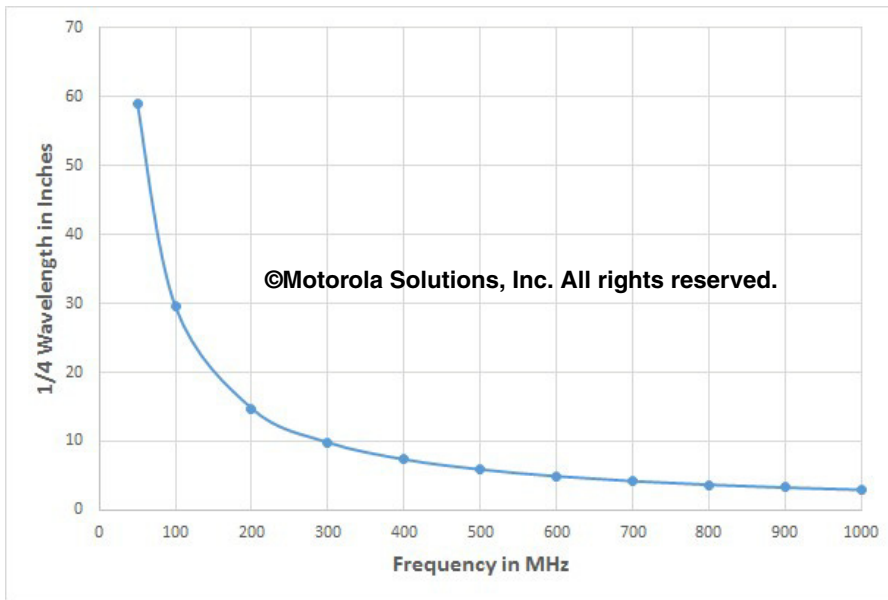

Figure G-31 Frequency versus $\frac{1}{4}$ Wavelength



NOTE

The wavelength of any given frequency can be calculated using the following formula: wavelength in meters = $300 / \text{frequency}$ in MHz. The wavelength is cut in half for every doubling of the frequency.

An example calculation for 156.8 MHz is as follows:

- Wavelength in meters = $300 / 156.8 \text{ MHz} = 1.91 \text{ m}$ (75.2 in.)
- $\frac{1}{4}$ wavelength = $1.91 \text{ m} / 4 = 0.48 \text{ m}$ (18.8 in.)

G.12.4 Mini-UHF Connection



NOTE

The information in this section is primarily taken from the *APX Mobiles Installation Manual*.

The mini-UHF connector is a common connector for Land Mobile Radio (LMR) and is covered in this subsection (see Figure G-32). The mini-UHF connector **shall** be installed according to manufacturer instructions, using manufacturer-approved crimping tool. A ratcheting crimp tool is recommended (see Figure G-33).



Figure G-32 Examples of Mini-UHF Connectors



Figure G-33 Example of Mini-UHF Ratcheting Crimp Tool (Motorola Solutions Part Number 6680388A26)

To ensure a secure connection of an antenna cable's mini-UHF plug to a radio's mini-UHF jack, their interlocking features must be properly engaged. If they are not properly engaged, the system will loosen. Using a tool (pliers or wrench) will not overcome a poor engagement, and is not recommended.



IMPORTANT

Applying excessive force with a tool can cause damage to the antenna jack or the connector (for example: stripping threads, deforming the collar or connector, or causing the connector to twist in the housing opening and break).

The mini-UHF connector tool (Motorola Solutions part number HLN6695) is designed to securely tighten the antenna plug-radio jack connection without damaging either the plug or the jack.

Motorola Solutions recommends the following sequence to ensure proper attachment of the system (see Figure G-34 and *APX Mobiles Installation Manual*):

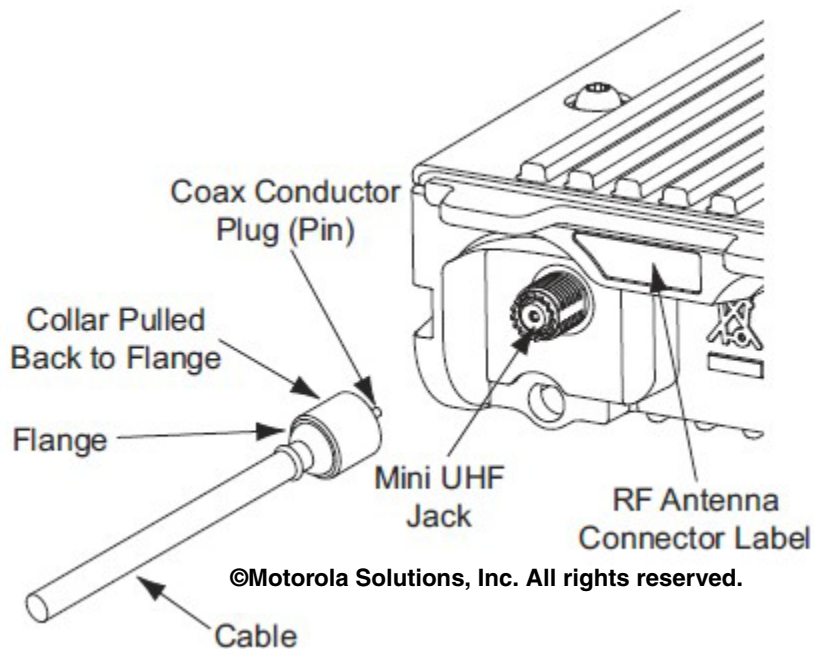

Figure G-34 Example of Mini-UHF Connection

1. Make sure that there is sufficient slack in the antenna cable.
2. Make sure that the collar of the antenna cable plug is loose and does not bind.
3. Make sure that the mini-UHF jack is tight in the radio housing.
4. Slide the collar back against the flange. Insert the antenna cable plug's pin fully into the radio jack, but do not engage the threads.
5. Ensure that the plug's and jack's interlocking features are fully seated. Check this by grasping the crimp on the cable jack, rotating the cable, and noting any movement. If the features are seated correctly, there should be **no** movement.
6. Finger-tighten the antenna cable plug's collar onto the radio's jack.
7. Give a final tug, by hand, to the collar, and tighten by hand as firmly as possible.
8. Slip the mini-UHF connector tool over the coaxial cable, using the gap between the tool's legs (see Figure G-35). Then, slide the tool up onto the plug's knurled collar. Squeeze the two straight legs of the tool firmly together between your thumb and index finger and turn clockwise (as shown) to tighten the collar. It should take one-quarter turn or less. When you feel the tool slipping on the collar, the connection has been properly tightened. The tool can also be used to loosen a tight collar.



IMPORTANT

DO NOT use pliers or any other device to grip the tightening tool. It has been designed to enable you to achieve the proper torque on the collar without excessive tightening. Excessive tightening of the collar can damage the connector and the radio.

©Motorola Solutions, Inc. All rights reserved.

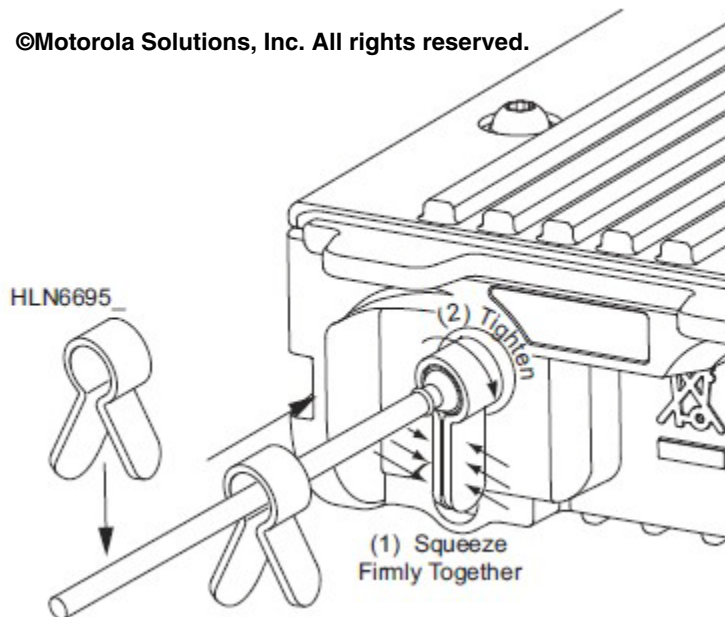

Figure G-35 Mini-UHF Connector Torque Tool

G.12.5 Antenna VSWR Testing

As part of the mobile radio installation, antennas **shall** be tested for proper Voltage Standing Wave Ratio (VSWR) or Return Loss (RL) (see FCS1362:2010 for more information). VSWR or RL testing may be completed using a through-line directional wattmeter (for example, Bird Technologies® APM-16) or a cable and antenna analyzer (for example, Anritsu Site Master™).

The antenna VSWR or RL **shall** meet the manufacturer specifications (see the antenna specification sheet). Typical mobile antenna VSWR specifications are 1.5:1 (RL = -14 dB) or 2.0:1 (RL = -9.54 dB).



IMPORTANT

Antennas shall be tuned according to manufacturer instructions, as applicable.



NOTE

The preferred method of testing an antenna is to use a cable and antenna analyzer. The cable and antenna analyzer allows a technician to easily see how the antenna is operating across the entire customer frequency spectrum.



NOTE

A VSWR of 1.5:1 or a RL of -14 dB is equivalent to 4% reflected power. A VSWR of 2.0:1 or a RL of -9.54 dB is equivalent to 11% reflected power.

When testing the antenna VSWR or RL, the following **shall** be followed:

- All vehicle doors, trunk, and hood **shall** be closed.
- All antennas, lightbars, and other metallic objects **shall** be installed on the vehicle. Metallic objects (including antennas other than the antenna under test) can impact the VSWR/RL measurement.
- Adapters **shall** be avoided as much as practicable. The wattmeter **shall** have the appropriate connectors installed.
- If using a wattmeter, the vehicle battery **shall** be fully charged or the vehicle **shall** be running during the test. Ensure adequate ventilation or test outdoors.
- The wattmeter or cable and antenna analyzer **shall** be in known good working condition and **shall** be within factory calibration tolerances.
- If VSWR testing is made using a directional wattmeter, the measured forward power output **shall** match the power recorded in “Transceiver Preventative Maintenance and Inspection” on page G-5. If the power does not match within $\pm 5\%$, a technician **shall** be engaged to troubleshoot the problem.



IMPORTANT

When testing the antenna VSWR using a wattmeter, it is important to check multiple frequencies across the customer frequency spectrum. This is to help ensure proper antenna match on all customer frequencies.



IMPORTANT

VSWR testing of digital format radios (for example: DMR, MOTOTRBO, P25 or TETRA) requires the use of a average reading power meter. An analog wattmeter will not provide accurate results.

**NOTE**

Analyzers are suitable for analog and digital systems, whereas the traditional analog power meter is only suitable for analog systems (see FCS1362:2010).

G.13 Effective Receiver Sensitivity Testing

Effective receiver sensitivity is a measure of how well a receiver performs under actual operating conditions. Effective receiver sensitivity can be degraded by nearby noise sources. Examples of such noise sources are, but not limited to, the following: emergency lights, high-intensity LED lights, mobile data computers, strobe lights, transmitters, vehicle charging systems, vehicle ignition systems, WiFi hotspots, wireless broadband cards, and so on

Mission critical land mobile radio installations **shall** be tested for effective receiver sensitivity. In large projects and/or fleet installations, only a small sample of each vehicle/installation type is required. Examples of vehicle/installation types include:

- Police Department Patrol 2016 Ford Explorer
- Police Department Patrol 2017 Ford Explorer
- Police Department Patrol Chevrolet Tahoe
- Police Department Traffic Dodge Charger
- Fire Department Ladder Truck
- Fire Department Engine
- Fire Department Medic Unit

Testing should include as many frequencies across the customer frequency band as practicable. For trunking radios, testing should be included on the available test channels (see the radio maintenance manual).

**IMPORTANT**

Testing may not be possible on active channels. Normal channel activity could appear as degradation during the test.

Effective receiver sensitivity testing requires the use of a capacitive coupler, commonly known as an Iso-T. Testing for receiver degradation and effective sensitivity is detailed in the following steps and summarized in Table G-5:

1. Turn off the vehicle and turn off all other vehicle systems, except the radio under test.
 - Ensure the vehicle battery is fully charged.
2. Measure and record basic sensitivity (in dBm) of the receiver as described in “Transceiver Preventative Maintenance and Inspection” on page G-5. See Figure G-36.
3. Configure the test setup as shown in Figure G-37. The communications analyzer (signal generator) is connected to the capacitively coupled (isolated) port.
4. Adjust the signal generator for 12 dB SINAD or 5% Bit Error Rate (BER). Record the value (in dBm).
5. Configure the test setup as shown in Figure G-38. The 50 ohm termination is replaced with the vehicle antenna.
6. Adjust the signal generator as required for 12 dB SINAD or 5% BER (the same method used in Step 4). Monitor the 12 dB SINAD or 5% BER for at least 60 seconds to help ensure that no intermittent interference exists. Record the value (in dBm).
7. Calculate the amount of receiver degradation (in dB) by subtracting the value recorded in Step 4 from the value recorded in Step 6. This value should be a positive number or zero.

8. Calculate the effective receiver sensitivity (in dBm) by adding the amount of receiver degradation (in dB) from Step 7 to the basic receive sensitivity value recorded in Step 1. Record the results.
9. Start the vehicle and all vehicle systems (for example: lightbars, LED running lights, data terminals, video recording system, sirens, RADAR devices, and so on).
10. Repeats steps 5 through 8 and record the results as required.
11. Report the findings to the System Engineer and/or System Manager.

Table G-5 EXAMPLE OF CALCULATION OF RECEIVER DEGRADATION

Step Number	Example Value	Notes
2	120 dBm	Typical value.
4	-90 dBm	50 ohm load is connected. The Iso-T "isolated" port and 6 dB attenuator have an isolation of 30 dB.
6	-89 dBm	The vehicle antenna is connected in place of the 50 ohm load.
7	-89 dBm - -90 dBm = 1 dB Mathematically rewritten as: -89 dBm + 90 dBm = 1 dB	The amount of receiver degradation is calculated as follows: Step 4 value subtracted from Step 6 value. In this example, 1 dB of receiver degradation is measured from the external environment (not vehicle systems).
8	-120 dBm + 1 dB = -119 dBm	The effective receiver sensitivity is calculated as follows: Step 2 value + Step 7 value. Effective Sensitivity = Basic sensitivity + receiver degradation. -120 dBm + 1 dB = -119 dBm
6	-87 dBm	The vehicle antenna is connected in place of the 50 ohm load. The vehicle is running and all vehicle systems are on.
7	-87 dBm - -90 dBm = 3 dB Mathematically rewritten as: -87 dBm + 90 dBm = 3 dB	The amount of receiver degradation is calculated as follows: Step 4 value subtracted from Step 6 value. In this example, 3 dB of receiver degradation is measured from the external environment and vehicle systems.
8	-120 dBm + 3 dB = -117 dBm	The effective receiver sensitivity is calculated as follows: Step 2 value + Step 7 value. Effective Sensitivity = Basic sensitivity + receiver degradation. -120 dBm + 3 dB = -117 dBm

**IMPORTANT**

Any degradation in receiver sensitivity shall be reported to the System Engineer and/or System Manager.

**NOTE**

Measurement of receiver degradation and/or effective receiver sensitivity **shall** be performed by a qualified technician.

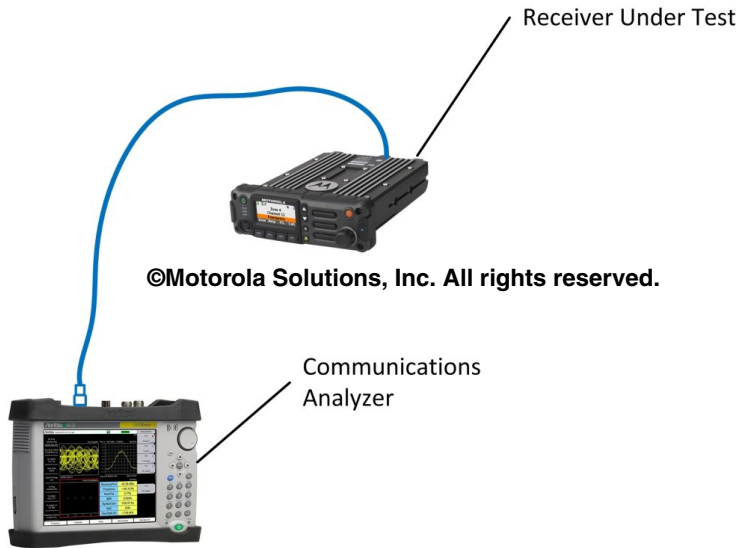

Figure G-36 Configuration for Measurement of Basic Receiver Sensitivity

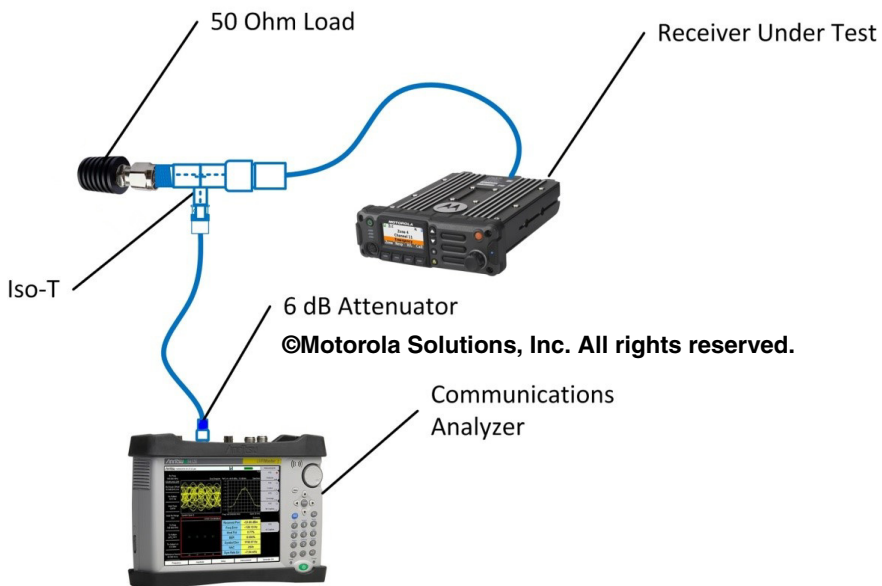

Figure G-37 Configuration for Measurement of Effective Receiver Sensitivity with 50 Ohm Load

 **NOTE**

The 6 dB attenuator shown in Figure G-37 and Figure G-38 helps provide impedance matching between the isolated port of the Iso-T and the communications analyzer. Proper impedance matching improves accuracy and repeatable results.



Figure G-38 Configuration for Measurement of Effective Receiver Sensitivity with Vehicle Antenna

Table G-6 provides a general summary of receiver degradation impact. Actual system coverage impact may vary on a per system basis. The measured receiver degradation **shall** be reported to the System Engineer and/or System Manager.

Table G-6 SUMMARY OF IMPACT OF RECEIVER DEGRADATION

Receiver Degradation	Impact of Findings
0 dB to 3 dB	This amount of degradation is generally considered normal.
3 dB to 5 dB	This amount of degradation is generally considered significant and may impact system coverage. Consult with the System Engineer. Troubleshooting for the degradation source is required.
5 dB to 10 dB	This amount of degradation is generally considered high and will degrade system coverage. Consult with the System Engineer. This level of degradation must be resolved or reduced to an acceptable level.
Greater than 10 dB	This amount of degradation is generally considered severe and will significantly degrade system coverage. Consult with the System Engineer. This level of degradation must be resolved or reduced to an acceptable level.

G.14 Radio Transmit Noise Testing

Perform the TX noise test using a convenient customer channel (such as a lesser used TAC channel) as follows:

**NOTE**

For digital systems (for example: DMR, MOTOTRBO, P25, or TETRA), this test may require the radio to be put in an analog test mode.

1. Connect the radio directly to the high power input port of the communications analyzer (see Figure G-39).
2. Start the vehicle engine and turn on vehicle systems (for example: data terminals, LED running lights, lightbars, RADAR devices, sirens, strobe lights, video recording system, and so on).

**WARNING**

Ensure adequate ventilation when running the vehicle.

3. Monitor the Radio's transmit (TX) channel with the communications analyzer.
4. With the engine running, key the radio and listen to the communications analyzer speaker for noise (alternator, engine, lightbar motors, strobes, and so on).
5. With the vehicle in park, rev the engine to approximately 1500 RPM (see FCS1362:2010) and listen for noise on the communications analyzer. If noise is present, troubleshoot the root cause and correct as needed.

**IMPORTANT**

The testing described in this section should also be completed with the vehicle siren running to help ensure the siren audio is not excessively coupled into the radio microphone. This test requires significant acoustical isolation from the receiver. As such, it may be more practical for a remotely located technician to monitor an over-the-air transmission using a customer subscriber unit. Obtain necessary customer permissions as needed when testing on an active channel.



Figure G-39 Example of Configuration for Transmitter Noise Test

G.15 Installation of Miscellaneous Equipment

Emergency vehicles often contain equipment and electronics beyond the two-way radio. Such equipment may be one or more of the following:

- Computers
- Lightbars
- RADAR systems
- Relays
- Sirens
- Strobe lights
- Video recording systems

The installation of other miscellaneous equipment should follow the general guidelines and requirements provided in this Appendix. The specific installation instructions from each equipment manufacturer **shall** be followed.

G.15.1 Power and Ground Sources

- See “Power Wiring for Mobile Installation” on page G-14.
- For vehicles with a Power Distribution Unit (PDU), it is recommended to use a PDU for radio equipment and other sensitive electronics, and a separate PDU for other types of emergency equipment (for example: lightbars, flashers, gun locks, strobe lights, and so on).
- For vehicles with a PDU ground, it is recommended to use one ground for radio equipment and other sensitive electronics, and a separate ground for other types of emergency equipment (for example: lightbars, flashers, gun locks, strobe lights, and so on).

G.15.2 Relays

For vehicles that use electromechanical relays to control external devices (for example: lights, motors, switch boxes, and so on), these relay circuits should be isolated as best as practicable from the mobile radio equipment (and other electronics). Diode suppression should also be used across the relay coil to minimize the noise produced by the collapsing magnetic field (see Figure G-40).

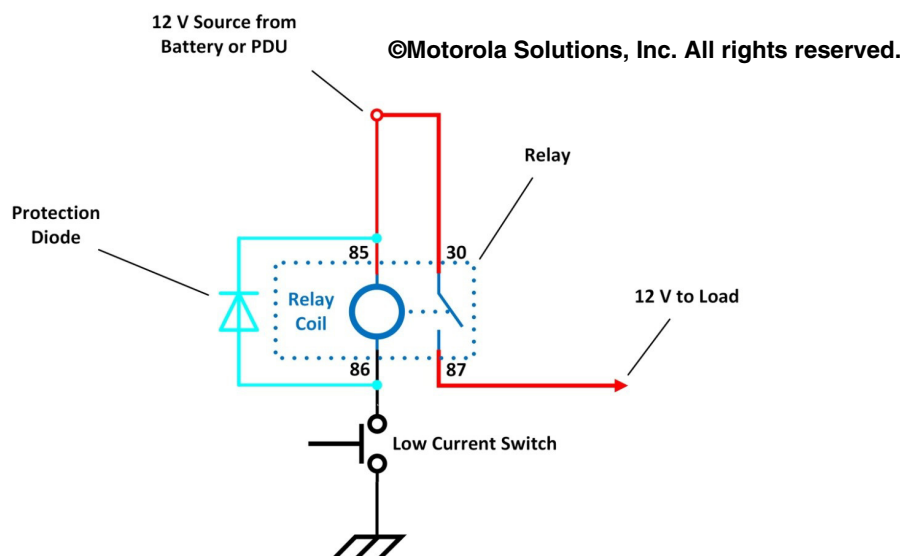

Figure G-40 Example of Relay Diode Wiring

NOTE

The numbers 30, 85, 86, and 87 in Figure G-40 represent the typical automotive relay terminal numbering standard.

G.15.3 Sirens

In addition to the specific instructions provided by the siren manufacturer, the following **shall** be observed:

- The siren speaker should be positioned with the sound projecting opening pointing forward, parallel to the ground, and not obstructed by structural components of the vehicle such as the radiator (NIJ Guide 500-00 and SAE J1849). See Figure G-41 for examples.
 - Mounting the siren under the hood and behind the radiator will result in a reduction of sound pressure levels at locations away from the vehicle and is not recommended (NIJ Guide 500-00 and SAE J1849).
- The siren speaker should be mounted as far from the vehicle occupants as practicable, preferably in the front grille area (NIJ Guide 500-00 and SAE J1849). See Figure G-41 for examples.
- Installation of two speakers, such as in high power output applications, require the speakers to be wired in phase (see Figure G-41). When connecting two speakers in parallel, wire similar speaker terminals together to ensure maximum loudness and prevent “dead spots.” For example, if the terminals are marked “1” and “2”, connect the terminals marked “1” together and connect those wires to one speaker lead. Connect the terminals marked “2” together and connect those wires to the other speaker lead (see Figure G-42).



Figure G-41 Examples of Siren Installations (Photos Courtesy of Whelen®)

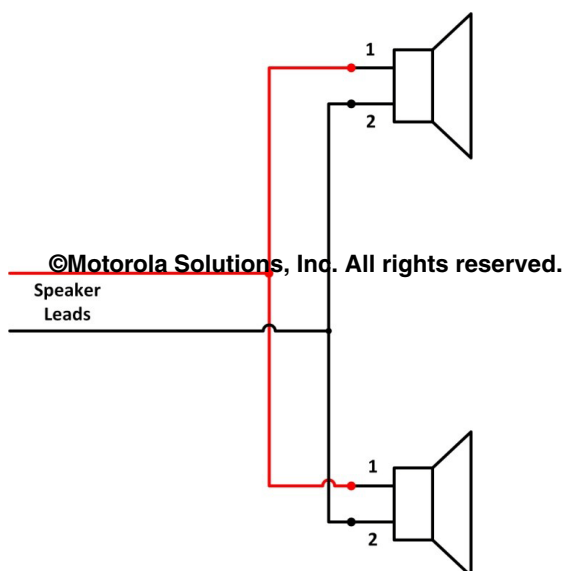

Figure G-42 Example of Two Siren Speakers Wired in Phase for High Power Output Applications

G.15.4 Strobe Lights

In addition to the specific instructions provided by the strobe light manufacturer, the following **shall** be observed:

- Strobe lights **shall** be installed according to manufacturer instructions.
- Strobe light cables **shall** maintain as much separation as practicable from vehicle and radio cabling/wiring.
- Strobe light cable shields **shall** be grounded according to manufacturer instructions.
- Strobe lights should use a separate Power Distribution Unit (PDU) from sensitive electronic equipment (such as computer and radio).
- Strobe lights should use a separate PDU ground (-) distribution point from sensitive electronic equipment (such as computer and radio).



NOTE

Light Emitting Diode (LED) technology lights are increasingly replacing strobe lights.

G.16 Motorcycle Installations

Motorcycle installations can be much more complicated than typical vehicle installations; therefore, only installers trained and experienced with motorcycle applications **shall** perform such installations.

In addition to the specific instructions provided by each equipment manufacturer, the following **shall** be observed:

- Equipment installed on motorcycles **shall** be rated for such installations and **shall** be appropriately weather-resistant as required.
- Equipment **shall** be installed according to manufacturer instructions.
- Equipment **shall** be installed in weather-resistant enclosures as applicable (see manufacturer instructions).
- Forward components (for example: control head, microphone, and speaker) **shall not** interfere with visual or physical access to controls and instruments.
- Forward components **shall not** interfere with the handling of the motorcycle.
- All components **shall** be securely mounted in order to withstand the constant vibration experienced on a motorcycle.
- Hardware used in motorcycle installations **shall** be stainless steel (or equivalent) to help prevent corrosion.
- Cabling **shall** be protected using a split loom (or equivalent) as necessary. See “Protection of Conductors and Cabling for Mobile Installation” on page G-11.
- Cabling **shall** be run so that it does not interfere with motorcycle operation. See “Routing of Conductors and Cabling for Mobile Installation” on page G-11.
- Cabling **shall** be routed away from motorcycle components that become hot during operation of the motorcycle. See “Routing of Conductors and Cabling for Mobile Installation” on page G-11.
- Cabling **shall** be secured using nylon cable ties (or equivalent) at frequent intervals as required to prevent damage caused by motorcycle vibration.
- Equipment positive (+) conductors (red) **shall** connect directly to the battery or other adequate motorcycle manufacturer provided power points. See the motorcycle manual and/or contact the dealer for more information.
- Equipment requiring an ignition sense voltage **shall** terminate to an adequate fuse box ignition point. See the motorcycle manual and/or dealer for location recommendations and current draw limitations.
 - If the current draw limitations on the motorcycle are inadequate, an ignition relay may be required.
- Equipment negative (-) conductors (black) **shall** be connected to an adequate chassis ground point on the motorcycle. See the motorcycle manual and/or contact the dealer for more information.
 - **Do not** connect the black conductor directly to the negative battery post.

**NOTE**

See “Antenna Installations on Non-Metallic Surfaces” on page G-32 for information regarding antenna installations with limited and/or no ground plane.

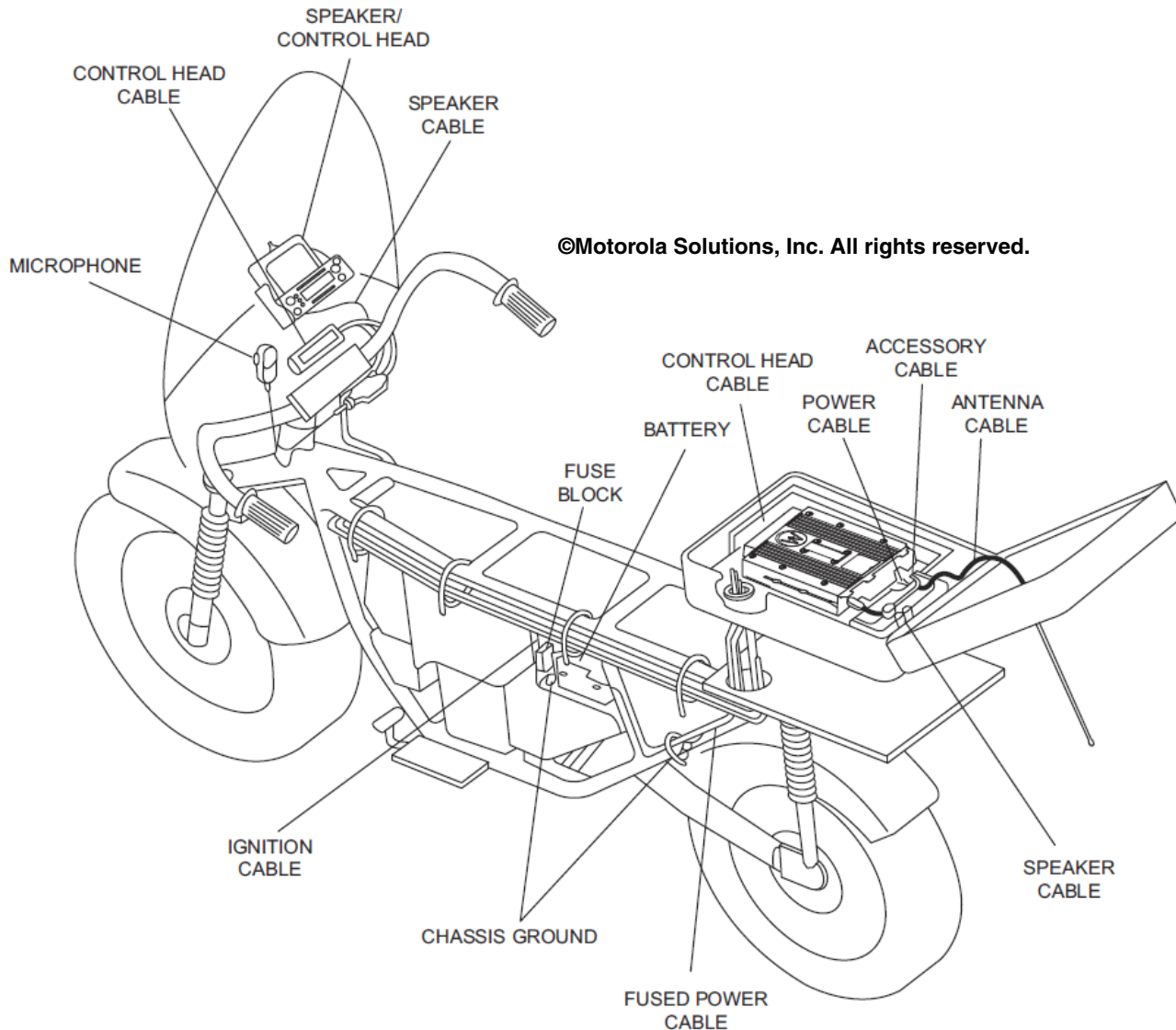

Figure G-43 Example of Motorcycle Radio Installation

G.17 Marine Installations

The information in this section applies to land mobile radios installed in marine applications, such as Police or Fire Department boats. Marine radios used for marine applications **shall** follow applicable installation requirements of the Authority Having Jurisdiction. See “Mobile Installer Training and Certification” on page G-3 for certification requirements and recommendations.

While under operation, a marine vessel can be subject to extreme vibration. Careful attention **shall** be given to proper mounting techniques and securing of equipment and associated cabling/wiring.

Installation of mission critical two-way radio equipment and associated devices, such as lightbars and sirens, **shall not** impede the functionality of other marine vessel equipment (for example, other radios and RADAR) or any functions pertaining to the operation of the vessel.

In addition to the specific equipment manufacturer instructions, the following **shall** be observed:

- Antennas and other equipment **shall** be installed away from the RADAR antenna as much as practicable, as required by the RADAR manufacturer.

**NOTE**

See “Antenna Installations on Non-Metallic Surfaces” on page G-32 for information regarding antenna installations with limited and/or no ground plane.

- Equipment power connections (positive) **shall** be made to an adequate marine vessel provided 12V power distribution point (+).
 - Equipment **shall** be fused according to manufacturer requirements.
 - See Figure G-44 for an example.
- Equipment power return (negative) **shall** be made to an adequate marine vessel provided power return bus (-).
- Power conductors **shall** be marine grade (see “Power Conductors for Mobile Installation” on page G-17).
- Mounting hardware **shall** be corrosion resistant (such as stainless steel). See “Securing Hardware for Mobile Installation” on page G-10.
- Electrical connection devices used in marine applications **shall** be suitable for marine applications. Marine application devices typically have the following characteristics:
 - Constructed from tinned-copper for improved corrosion resistance.
 - Contain adhesive lined heat shrink insulator to seal connection from vibration and to provide improved strain relief.
 - See “Electrical Ring Terminals, Lugs, Splices, and Similar Devices” on page G-24 for more information.
- Mechanical electrical connections should use a conductive antioxidant compound.
 - The antioxidant compound **shall** be designed for electrical connections.
 - The antioxidant compound **shall** be approved for marine applications (see manufacturer instructions).
- Marine grade coax **shall** be used.
 - Marine grade coax is designed for UV and salt environments.
 - Marine grade coax center conductor and outer shield are tinned for corrosion resistance.
 - Marine grade coax typically has a white outer jacket.
- The use of marine grade antennas is recommended. Standard vehicle antennas are highly prone to corrosion from salt air.

**NOTE**

Standards from the National Marine Electronics Association and the American Boat & Yacht Council should be referred to for more details.



Figure G-44 Example of Marine 12V DC Power Distribution Panel (Photo Courtesy of Blue Sea Systems)

G.18 Aircraft Installations

The following paragraph applies to aircraft installations in the United States. Installations outside of the United States **shall** follow the requirements of the local jurisdiction.

Installations in aircraft carry additional requirements and responsibilities which are beyond the scope of this Appendix. However, persons performing these installations should hold an Airframe and Powerplant Certification, and work **shall** be inspected by an Airframe and Powerplant Certificate Holder with Inspection Authorization. Equipment installed in aircraft **shall** have an approved STC (Supplemental Type Certificate) or FAA Field Approval for the aircraft in which the equipment is to be installed.

G.19 Example of Installation Checklist

This section contains an example of a pre-install and post-install checklist. A customer specific checklist may need to be created for customer specific installation requirements.

Installation Checklist

Date			
Customer			
Project			
Vehicle Make		License/Vehicle Number	
Vehicle Model		Mileage	
Radio Model		Radio ID #	
Radio SN		Radio Asset #	
Radio Firmware			

Vehicle Condition

* Note any existing physical damage on "Existing Vehicle Damage Form" at the end of this document.

	Pre	Post		Pre	Post
Low - Beams			Door Locks		
Hi-Beams			Power Windows		
Brake Lights			Wipers Front		
Left Signal			Wipers Rear		
Right Signal			Power Mirrors		
Hazard Lights			Power Seats		
Fog Lights			AM / Radio		
Reverse Lights			Clock		
Running Lights			Interior Light		
Air Conditioning			Trunk Light		
Seat Belt Operation			Instrument Lights		
SRS (Air Bag)			Roof Lining		
Engine Compartment Light			12 vDC Power Ports		
Check Engine Light			Horn		
Interior Trim			Fluid Leaks		

Installation Checklist (continued)

Vehicle Condition Items Not Listed on Previous Page

	Pre	Post

Accessories

	Pre	Post		Pre	Post
Light bar			Spotlight		
Headlight Flasher			Gun Release		
Corner Strobes			P/A		
Siren			Air Horn		
Siren Park Kill			Horn/Ring		
Take Downs			Map Light		
Alley Lights			Pump Panel Lights		
Ignition Bypass			Radio Power-up - No Key		
Existing Radios					
RADAR			Radio Off With Key		

Accessories Items Not Listed Above	Pre	Post

Installation Checklist (continued)

Installation Information	
Equipment	Equipment Location
Transceiver	
Control Head	
Microphone	
Speaker	
Antenna	
Other Equipment	Equipment Location

Power Cable Gage		AWG
Antenna Model		

Antenna Frequency		MHz
-------------------	--	-----

Radio Testing			
Wattmeter Model		Wattmeter SN	

TX Forward Power		Watts
Voltage Drop During Transmit		vDC

TX Reflected Power		Watts
--------------------	--	-------

$VSWR = (1 + \text{sq. root } (P(r)/P(f))) / (1 - \text{sq. root } (P(r)/P(f)))$		VSWR (< 1.5:1)
--	--	----------------

Communications Service Monitor Model		SN	
--------------------------------------	--	----	--

Radio Receiver Basic Sensitivity		dBm
Radio Receiver Effective Sensitivity		dBm

Installation Checklist (continued)

Radio Check

	Pass	Fail		Pass	Fail
Channel Name:					
Outbound Voice Heard Clearly				Inbound Voice Heard Clearly	
Channel Name:					
Outbound Voice Heard Clearly				Inbound Voice Heard Clearly	
Channel Name:					
Outbound Voice Heard Clearly				inbound Voice Heard Clearly	

Equipment installed correctly according to installation requirements:	Yes	No
Customer Name		
Customer Signature		
Installer Name		
Installer Signature		
Notes		

Installation Checklist (continued)

Existing Vehicle Damage

Location(s) of Damage Observed:

Notes:

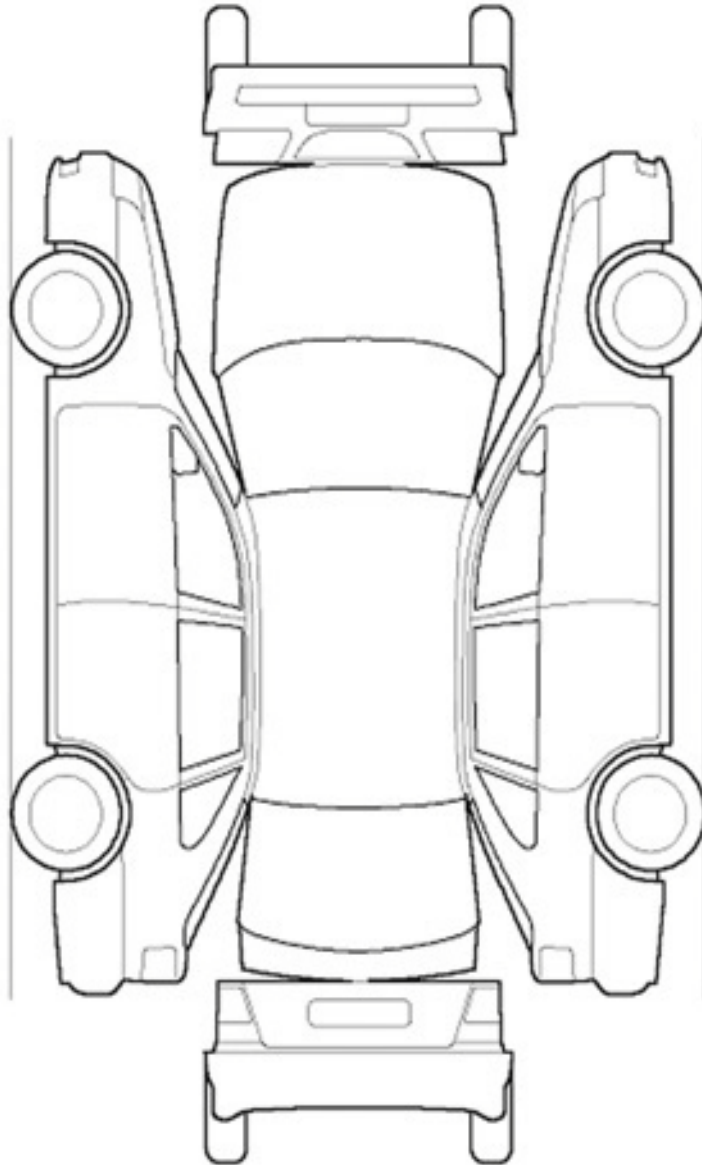

THIS PAGE INTENTIONALLY LEFT BLANK.

INDEX

acceptable rectifier types	6-25	A	antenna masts:grounding	4-114
acceptance testing	2-13		antennas	
access point and wireless router grounding	4-40, 4-126		EME considerations	A-1
air conditioning	3-10		interference protection recommendations	8-1
air terminals	2-18		loading requirements	2-19
alarms			antennas:interference protection recommendations	8-1
fire detection	3-25		antennas:protection requirements (final output-to-antenna) .	8-1
temperature	3-12		arctic regions:grounding in	4-144
alternate power sources	6-29		Australian standards	1-9
Americans With Disabilities Act	2-8			
		B		
backfilling requirements	2-11		bleach	
batteries			floor mopping mixture	3-10
charging	6-36		bonding methods:exothermic welding	4-64
installation	6-36		branch circuit breaker	6-10
maintenance disconnect	6-38		building ground ring	4-25
multiple	6-35		buildings	
required signage	6-34		design requirements	3-1
temperature requirements	6-36		buildings/shelter	
battery backup duration	6-34		definition	3-2
battery backup, high rate applications	6-34		off-loading considerations	3-5
battery backup, long duration	6-34		buildings/shelters	
battery containment area	6-33		lighting	3-19
battery safety	6-31		sealing	3-9
battery safety equipment	3-29		bus bar:external grounding	4-43
battery systems	6-31		bus bar:tower ground	4-46
bending radius for grounding conductors	4-38			
		C		
cabinet			cabling	
definition	3-2		fiber optic	2-17
cable			power cabling capacity	6-26
support requirements	2-21		calculating soil resistivity for complex ground rod systems	
cable bridge:grounding	4-108		B-29	
cable management	3-16		calculating soil resistivity from test results	B-19
cable tray			cathodic protection	4-90
installation	3-13		causes of power quality problems	6-18
selection	3-14		caution symbol, definition	1-3
under raised floors	3-16		ceiling considerations	3-7
wire mesh	3-16		charging backup batteries	6-36

- circuit breaker
 - branch6-10
- circuit protection6-10
- cleaning
 - rodent droppings3-10
- communications systems on-site3-30
- concrete
 - anchors2-10
 - forms2-11
 - preparation2-10
 - temperature requirements2-11
- concrete foundation design2-10
- concrete-encased electrodes2-10, 4-23, 4-138

- DC power budget6-28
- DC power distribution center6-26
- dedicated communications buildings:grounding4-92
- disconnect for battery maintenance6-38
- disconnect, fused6-5
- dispatch centers co-located with tower4-122
- dissimilar metals and corrosion control4-52
- distance between tower and building2-17

- effect of ground rod size on resistance to earth4-17
- effects of power quality problems6-21
- electrical service installation2-8
- electrical service requirements6-4
- electrical service requirements, interior6-8
- electrodes, grounding (earthing)4-8
- electrolytic ground rods4-19
- electromagnetic energy
 - action thresholdsA-21
 - EME zoningA-7
 - engineering considerationsA-10
 - environmental evaluationA-2
 - exposure evaluationA-4
 - exposure standards and limits guidelinesA-2
 - general information regarding criteriaA-1
 - personal monitorsA-21
 - personal protective equipmentA-20

- fans, exhaust3-12
- Federal Aviation Administration2-18
- Federal Clean Water Act (FCWA)2-8
- ferroresonant rectifier6-25
- fiber optic
 - cabling2-17
- fire
 - planning2-10
- conductors
 - requirements6-10
- conduit
 - requirements6-11
- constructability review2-6
- construction
 - towers2-20
- controlled ferroresonant rectifier6-25
- corrosion control4-52, 4-55
- corrosion control:cathodic protection4-90
- corrosion, galvanic4-54
- counterpoise grounding conductors4-28

- D**
- down conductor grounding4-116
- drawings
 - site development2-3
 - site drawings of record2-22
 - tower design2-15
- drip loop
 - example2-21
- droppings, rodent3-10

- E**
- signageA-17
- work practicesA-14
- electrostatic discharge protectionC-1
- emergency lighting3-19
- encasement material:grounding electrodes4-36
- enhancing grounding electrode systems4-78
- entry port4-46
- equipment
 - EME personal monitorsA-21
 - EME personal protective equipmentA-20
- exhaust fans3-12
- exothermic welding4-64
- exposure evaluation for EMEA-4
- extension cords, use of6-11
- external ground bus bar (EGB)4-43
- external ground bus bar:illustration4-46
- external ground bus bar:specifications4-44

- F**
- alarm3-25
- protection3-20
- suppression2-8
- suppression systems3-25
- first aid equipment3-29
- floors
 - cable management under3-16

design considerations	3-8
loading	3-7
mopping for rodent droppings	3-10
foundation and soils monitoring requirements	2-12
foundation considerations	3-6

Galvanic corrosion	4-54
Galvanic corrosion:example of	4-88
General Conversions and Formulas	E-1
generator	
fuel supply	6-40
grounding	6-43
installation	6-43
installation plan	6-42
placement	6-39
standby	6-38
startup	6-44
generator safety	6-44
generators:grounding	4-93
geotechnical considerations	2-5
glossary of terms	1-13
ground plates	4-21
ground ring:building and tower	4-25
ground rods:angled	4-13, 4-14
ground rods:concrete-encased electrodes	4-23
ground rods:effect of length on resistance	4-17
ground rods:electrolytic	4-19
ground rods:installation	4-13
ground rods:parallel	4-17
ground rods:plates	4-21
ground rods:specifications	4-12
ground rods:typical single rod installation	4-16
ground system testing	
safety precautions	D-1
ground test wells	4-35
grounding	
generators	6-43
PANI system	5-76
grounding (earthing) electrode: spacing for maximum effectiveness	4-10
grounding (earthing) electrodes	4-8
grounding (earthing): minimum requirements	4-74
grounding (earthing):metal shipping containers	4-131
grounding conductors:bending	4-38
grounding conductors:counterpoise	4-28
grounding conductors:general specifications	4-37

hantavirus	3-10
hantavirus precautions	3-10
hardwiring of receptacles	6-11

foundation design for prefabricated shelters	2-10
foundation monitoring services	2-9
foundations	2-10
fuel supply for backup power generators	6-40
fused disconnect	6-5

G

grounding conductors:protecting and securing	4-39
grounding conductors:radial	4-28
grounding electrode system resistance	4-76, 4-78
grounding electrode system testing	D-1
grounding electrode:encasement material	4-36
grounding electrode:sphere of influence	4-9
grounding in	4-141
grounding system:supplementing	4-78
grounding system:tower	4-79
grounding:arctic regions	4-144
grounding:cable bridge/ice bridge	4-108
grounding:dedicated communications buildings	4-92
grounding:dispatch centers co-located with tower	4-122
grounding:down conductors	4-116
grounding:generators	4-93
grounding:guyed tower guy anchor points	4-86
grounding:guyed towers	4-83
grounding:metallic building siding	4-111
grounding:metallic objects requiring bonding	4-101
grounding:mountaintops	4-138
grounding:outdoor cabinets	4-94
grounding:RF transmission lines and preamplifiers	4-96
grounding:roof-mounted antenna masts	4-114
grounding:rooftop-mounted tower structures	4-119
grounding:sand, coral and limestone environments	4-143
grounding:self-supporting towers	4-80
grounding:shallow topsoil areas	4-141
grounding:side-mounted antenna	4-117
grounding:sites with limited space	4-136
grounding:soilless areas	4-140
grounding:towers with limited space	4-137
grounding:two or more structures or facilities located in same area	4-124
grounding:wireless access points and routers	4-40, 4-126
grounding:wooden poles	4-91
guy anchor points:grounding	4-86
guyed towers	
comparison	2-15
guyed towers:grounding	4-83

H

health hazards	
hantavirus	3-10
heating	

heat pumps3-12
 thermostats3-12
 heating, ventilation, and air conditioning3-10
 horizontal lightning rods2-18
 HVAC
 alarms3-12

ice bridge
 isolation from building2-17
 support requirements2-21
 ice bridge:grounding4-108
 installation
 fire extinguishers3-25
 transmission lines2-21
 installation:angled ground rods 4-13, 4-14

land surveys2-4
 light duty site4-75
 lighting
 emergency3-19
 lighting considerations3-19
 lightning
 central office protection3-13
 isolation of ice bridge2-17
 reducing effects of2-16
 lightning rods2-18
 lightning:activity worldwide4-3
 lightning:frequency4-5

material safety and data sheets6-32
 metal shipping containers used as communication
 sites:grounding4-131
 metallic building siding, grounding4-111
 metallic objects requiring bonding4-101
 metals:dissimilar, preventing corrosion4-52
 Metric/English Units Conversion E-1

neutral conductor6-11
 neutral-ground bond
 location2-3

Occupational Safety and Health Administration2-10
 off-loading buildings/shelters3-5
 organization of this manual1-2
 outdoor cabinets:grounding4-94

heat pumps 3-12
 preventive maintenance program 3-13
 thermostats 3-12
 wall-mounted units 3-11
 HVAC systems 3-10

I

installation:typical single ground rod 4-16
 installing batteries 6-36
 installing generators 6-42, 6-43
 integrated cable entry port 4-46
 interconnection wiring between the generator, transfer
 switch, and site AC mains 6-41
 interference:received protection 8-3

L

lightning:maps 4-3
 line-to-neutral (normal mode) surge suppression 6-7
 loading report example 2-19
 loading requirements
 towers 2-19
 location
 site buildings/building/shelter design and location con-
 siderations 3-3
 location of neutral-ground bond 2-3, 6-5
 location of utility entrance 2-3
 low voltage disconnect 6-26

M

minimum grounding (earthing) requirements 4-74
 monopole towers
 comparison 2-15
 monopole towers:grounding 4-80
 Motorola Site Design and Integration Team 2-2
 mountaintops:grounding 4-138
 multiple battery strings 6-35

N

location of 6-5
 New Zealand standards 1-9
 nomograph, soil resistivity testing B-12

O

outdoor electrical equipment 6-9
 outdoor receptacles 6-9
 overcurrent protection 6-26

panelboard marking	6-8
PANI grounding system sequence	5-76
parallel ground rods	4-17
permits	2-7
permitting, zoning, code and regulatory considerations ..	2-7
personal protective equipment	6-32
placement of generator	6-39
planning	
location of neutral-ground bond	2-3
location of utility entrance	2-3
site development drawings	2-3
staking considerations	2-4
temporary facilities	2-4
plate, ground	4-21
plenum cabling	6-26
power	
stand-alone system	6-30
power cabling	
floor and ceiling, plenums	6-26
power cabling capacity	6-26

R56 Manual	
organization	1-2
radial grounding conductors	4-28, 4-138, 4-143
receiver protection requirements	8-3
receptacle	
outdoor	6-9
receptacle strips	6-17
receptacles	
hardwiring	6-11
rectifier	
ferroresonant	6-25
silicon-controlled	6-25
switchmode	6-25
rectifier sizing	6-25
rectifiers	6-25
referenced standards	1-4
regulations	

safety	
batteries	3-29, 6-31
definition of caution symbol	1-3
definition of warning symbol	1-3
EME exposure standards and limits guidelines	A-2
EME personal monitors	A-21
EME personal protective equipment	A-20
EME warning	1-3
emergency lighting	3-19
equipment required at communication sites	3-29

P

power panel requirements	6-9
power quality	6-18
effects of problems	6-21
problem remedies	6-21
problems	6-18
recommended test thresholds	6-22
power quality action plan	6-23
power quality testing locations	6-23
power sources	3-28
alternatives	6-29
protecting at central offices	3-13
power supply	
uninterruptible	6-28
power system	
DC distribution center	6-26
sizing	6-25
preamplifier:grounding	4-96
preventive maintenance	
HVAC	3-13
protecting and securing grounding conductors	4-39

R

towers	2-18
regulatory considerations	2-7
remedies for power quality problems	6-21
requirements	
foundation and soils monitoring	2-12
resistance to earth of a straight horizontal electrode	4-30
rest platforms	2-14
RF	
interference protection recommendations	8-1
RF energy exposure	2-1
RF transmission lines:grounding	4-96
RF:interference protection recommendations	8-1
RF:minimum receiver protection requirements	8-3
RF:minimum transmitter protection requirements	8-1
rod arrangement, soil resistivity testing	B-8
rodent droppings	3-10
rooftop mounted towers:grounding	4-119

S

fire protection	3-20
general guidelines	1-3
generators	6-44
ground system testing	D-1
hantavirus precautions	3-10
on-site communications	3-30
RF energy exposure	2-1
signage	3-31
soil resistivity testing	B-1
statements and symbols defined	1-2

- towers2-18
 - warning signage3-27
 - work practices involving EMEA-14
 - safety climb2-14
 - sand, coral and limestone areas4-143
 - sealing buildings/shelters3-9
 - securing towers2-18
 - seismic considerations3-5
 - selecting cable trays3-14
 - self-supporting ice bridge2-21
 - self-supporting towers
 - comparison2-15
 - self-supporting towers:grounding4-80
 - separately derived transformers6-7
 - shallow topsoil4-141
 - shelter
 - definition3-2
 - side mounted antenna:grounding4-117
 - signage
 - battery rooms6-34
 - EME caution and warningsA-17
 - panelboards and switch boards6-8
 - signs
 - minimum required onsite3-31
 - warning3-27
 - silicon controlled rectifier6-25
 - single ground rod installation4-16
 - site
 - drawings of record2-22
 - site acceptance testing2-13
 - site categories3-1
 - building3-2
 - cabinet3-2
 - shelter3-2
 - vault3-2
 - Site Design and Integration Team2-2
 - site development drawings2-3
 - site development task list2-2
 - site preparation
 - soil resistivity testingB-6
 - site walks2-6
 - sites with limited space for external grounding systems ...4-136
 - sizing of power system rectifier6-25
 - sizing the site power system6-25
 - soil resistivity
 - site preparationB-6
 - test procedureB-7
 - testing methodsB-5
 - variabilityB-2
 - soil resistivity testing
 - blank worksheetB-15
 - calculationsB-19
 - complex ground rod calculationsB-29
 - equipment and suppliesB-6
 - example worksheetB-12
 - interpreting resultsB-11
 - rod arrangementB-8
 - soil resistivity testing safety considerationsB-1
 - soilless ground system4-140
 - solar power system
 - requirements6-30
 - solar/wind systems6-29
 - spacing of grounding electrodes4-10
 - staking considerations2-4
 - stand-alone power system6-30
 - standard duty site4-75
 - standards1-4
 - Australia1-9
 - New Zealand1-9
 - websites1-12
 - standby generators6-38
 - structural live load capacity3-7
 - structural soils and foundation work2-9
 - supplemental grounding4-78
 - surge suppression
 - line-to-neutral (normal) mode6-7
 - switchmode rectifier6-25
- T**
- temporary facilities during construction2-4
 - test equipment and supplies for soil resistivity testing ..B-6
 - test procedure for soil resistivity testingB-7
 - test results
 - soil resistivityB-11
 - testing
 - grounding electrode systemD-1
 - thresholds for power quality6-22
 - testing methods, soil resistivityB-5
 - TGB4-46
 - thermostats3-12
 - tower

access control	2-18	towers:grounding where space is limited	4-137
comparison of tower types	2-15	towers:monopole, grounding	4-80
construction	2-20	towers:rooftop-mounted, grounding	4-119
design and construction	2-14	transfer switch	6-41
design drawings	2-15	transformer	
distance from building	2-17	separately derived	6-7
drip loop	2-21	transmission line	
loading report example	2-19	drip loop	2-21
loading requirements	2-19	installation requirements	2-21
regulations affecting	2-18	type ÒAÓ site	4-75
safety guidelines	2-18	type ÒAÓ site grounding (earthing) electrode system resis-	
tower ground bus bar	4-46	tance	4-77
tower ground ring	4-25	type ÒBÓ site	4-75
tower grounding (earthing)	4-79	type ÒBÓ site grounding (earthing) electrode system resis-	
tower mapping	2-15	tance	4-77
		U	
Ufer ground	2-10, 4-23	utility entrance, location	2-3
under floors	3-16	utility locator service	2-9
uninterruptible power supply requirements	6-28		
		V	
		definition	3-2
		W	
variability of soil resistivity	B-2	standards organizations	1-12
vault		wind/solar systems	6-29
		wire mesh cable trays	3-16
wall-mounted HVAC	3-11	wooden poles:grounding	4-91
warning		worksheet for soil resistivity testing	B-15
EME monitoring	1-3	worksheet sample, soil resistivity testing	B-12
warning symbol definition	1-3		
weatherproofing	3-8		
websites			
		Z	
zoning considerations	2-7		

